

ORDER OF SHEETS

Section No.	1	Title
Section No.	2	Typical Sections and Details
Section No.	3	Estimate of Quantities
Section No.	3	Miscellaneous Quantities
Section No.	4	Right of Way Plat
Section No.	5	Plan and Profile
Section No.	6	Standard Detail Drawings
Section No.	7	Sign Plates
Section No.	8	Structure Plans
Section No.	9	Computer Earthwork Data
Section No.	9	Cross Sections

TOTAL SHEETS = 372



09

DESIGN DESIGNATION 2230-07-03

A.A.D.T.	2024	= 12,900
A.A.D.T.	2044	= 14,600
D.H.V.		= 1,460
D.D.		= 50/50
T.		= 2.2%
DESIGN SPEED		= 35 MPH
ESALS		= 840,000

CONVENTIONAL SYMBOLS

PLAN	
CORPORATE LIMITS	
PROPERTY LINE	
LOT LINE	
LIMITED HIGHWAY EASEMENT	
EXISTING RIGHT OF WAY	
PROPOSED OR NEW R/W LINE	
SLOPE INTERCEPT	
REFERENCE LINE	
EXISTING CULVERT	
PROPOSED CULVERT (Box or Pipe)	
COMBUSTIBLE FLUIDS	
MARSH AREA	
WOODED OR SHRUB AREA	

PROFILE	
GRADE LINE	
ORIGINAL GROUND	
MARSH OR ROCK PROFILE (To be noted as such)	
SPECIAL DITCH	
GRADE ELEVATION	
CULVERT (Profile View)	
UTILITIES	
ELECTRIC	
FIBER OPTIC	
GAS	
SANITARY SEWER	
STORM SEWER	
TELEPHONE	
WATER	
UTILITY PEDESTAL	
POWER POLE	
TELEPHONE POLE	

BEGIN PROJECT
STA 23+18.24
Y= 377,131.94
X= 2,539,709.10

STATE OF WISCONSIN
DEPARTMENT OF TRANSPORTATION
PLAN OF PROPOSED IMPROVEMENT
V WEST MILW W GREENFIELD AVENUE
S 56TH STREET TO S 47TH STREET
LOCAL STREET
MILWAUKEE COUNTY

STATE PROJECT NUMBER
2230-07-73



TOTAL NET LENGTH OF CENTERLINE = 0.498 MI.

HORIZONTAL POSITIONS SHOWN ON THIS PLAN ARE WISCONSIN STATE PLANE COORDINATE SYSTEM, NORTH AMERICAN DATUM OF 1927 (NAD27) IN U.S. SURVEY FEET. POSITIONS SHOWN ARE GRID COORDINATES, GRID BEARINGS, AND GRID DISTANCES. GRID DISTANCES ARE THE SAME AS GROUND DISTANCES.

ELEVATIONS ARE REFERENCED TO THE NATIONAL GEODETIC VERTICAL DATUM OF 1929 (NGVD29)

STATE PROJECT	FEDERAL PROJECT	
	PROJECT	CONTRACT
2230-07-73	WISC 2024114	1

ACCEPTED FOR

VILLAGE of WEST MILWAUKEE

Kim Egan
Kim Egan, Village Administrator
July 17, 2023
(Date) (Signature & Title of Official)

ORIGINAL PLANS PREPARED BY

GRAEF
WISCONSIN
DOUGLAS J. ROGAHN
E-32446
OTTAWA, WI
PROFESSIONAL ENGINEER

7-14-23 *Douglas J. Rogahn*
(Date) (Signature)

STATE OF WISCONSIN
DEPARTMENT OF TRANSPORTATION

PREPARED BY

Surveyor _____ GRAEF
Designer _____ GRAEF
Project Manager _____ MICHAEL BAIRD
Regional Examiner _____
Regional Supervisor _____ BRIAN BOOTHBY

APPROVED FOR THE DEPARTMENT

DATE: 7/18/2023 *Michael J. Baird*
(Signature)

E

GENERAL NOTES

NO TREES OR SHRUBS ARE TO BE REMOVED UNLESS INDICATED FOR REMOVAL BY THE ENGINEER.

THE EXACT LOCATION OF PRIVATE ENTRANCES ARE TO BE DETERMINED IN THE FIELD BY THE ENGINEER.

ALL RADIUS DIMENSIONS FOR CURB & GUTTER ARE GIVEN TO THE FLANGE. ALL ELEVATIONS ALONG CURB & GUTTER ARE GIVEN TO THE FLANGE. OFFSETS NOTED ARE TO THE FLANGE OR EDGE OF LANE IF NO CURB, UNLESS OTHERWISE NOTED. POINT CALLOUTS FOR INTEGRAL CURB & GUTTER GIVEN TO FACE OF CURB AND LABELED AS SUCH IN POINTS TABLE.

THE LOCATION OF KNOWN EXISTING UTILITIES IN THE VICINITY OF THE PROJECT ON THE PLANS IS APPROXIMATE. THERE MAY BE OTHER UTILITIES IN THE AREA THAT ARE NOT SHOWN.

HMA PAVEMENT WHERE INDICATED ON THE PLANS, SHALL CONSIST OF LAYERS AS FOLLOWS, UNLESS OTHERWISE NOTED ON THE PLANS OR DIRECTED BY THE ENGINEER.

2" DEPTH - 2" OF HMA PAVEMENT 4 LT 58-28 S AS THE UPPER LAYER

ASPHALT AND CONCRETE DRIVEWAYS SHALL BE SAWCUT AT THE MATCH LINE AS SHOWN ON THE PLANS OR AS DIRECTED BY THE ENGINEER.

THE CONTRACTOR SHALL NOTIFY DIGGERS HOTLINE AND AFFECTED UTILITIES PRIOR TO THE START OF WORK. ANY LOCAL MUNICIPAL UTILITY WHICH IS NOT A MEMBER OF THE DIGGERS HOTLINE MUST BE CONTACTED SEPARATELY.

TRAFFIC CONTROL DEVICES SHALL BE ADJUSTED TO FIT FIELD CONDITIONS AS DIRECTED BY THE ENGINEER.

CONCRETE JOINTS SHALL MATCH ABUTTING PAVEMENT AND CURB AND GUTTER JOINTS UNLESS OTHERWISE DESIGNATED BY THE ENGINEER.

CONTACT THE PROJECT ENGINEER AND THE SOUTHEASTERN WISCONSIN REGIONAL PLANNING COMMISSION (SEWRPC), AT LEAST TWO WEEKS PRIOR TO WORK NEAR ANY PUBLIC SURVEY MONUMENT.

STANDARD ABBREVIATIONS

AEW	APRON END WALL
AGG	AGGREGATE
BAD	BASE AGGREGATE DENSE
BM	BENCH MARK
C&G	CURB AND GUTTER
C/L	CENTER OR CONSTRUCTION LINE
CONC	CONCRETE
CP	CULVERT PIPE
CPCM	CULVERT PIPE CORRUGATED METAL
CPRC	CULVERT PIPE REINFORCED CONCRETE
CPRCHE	CULVERT PIPE REINFORCED CONCRETE HORIZONTAL ELLIPTICAL
CSCP	CORRUGATED STEEL CULVERT PIPE
CSPA	CORRUGATED STEEL PIPE ARCH
CSD	CONCRETE SURFACE DRAIN
CY	CUBIC-YARD
D	DEGREE OF CURVE
Δ	DELTA
DISCH	DISCHARGE
FE	FIELD ENTRANCE
HERCP	HORIZONTAL ELLIPTICAL REINFORCED CONCRETE PIPE
HMA	HOT MIX ASPHALT
INV	INVERT
L	LENGTH OF CURVE
LHF	LEFT HAND FORWARD
LT	LEFT
MIN	MINIMUM
M/L	MATCHLINE
NB	NORTHBOUND
NC	NORMAL CROWN
NTS	NOT TO SCALE
PAVT	PAVEMENT
PB	PULL BOX
PC	POINT-OF-CURVE
PCC	POINT OF COMPOUND CURVE
PE	PRIVATE ENTRANCE
PI	POINT OF INTERSECTION
PLE	PERMANENT LIMITED EASEMENT
PT	POINT OF TANGENT
PVC	POINT OF VERTICAL CURVE
PVI	POINT OF VERTICAL INTERSECTION
PVT	POINT OF VERTICAL TANGENT
R	RADIUS OF CURVE
R/L	REFERENCE LINE
R/W	RIGHT OF WAY
RAD	RADIUS
RC	REVERSE CROWN
RCAEW	APRON ENDWALL FOR CULVERT PIPE REINFORCED CONCRETE
RCHES	REINFORCED CONCRETE HORIZONTAL ELLIPTICAL STORM SEWER
RCPSS	REINFORCED CONCRETE PIPE - STORM SEWER
REQD	REQUIRED
RHF	RIGHT HAND FORWARD
RO	RUN OFF LENGTH
RT	RIGHT
SALV	SALVAGED
SB	SIGNAL BASE
SDD	STANDARD DETAIL DRAWING
SE	SUPER ELEVATION
SF	SQUARE FOOT
STA	STATION
SY	SQUARE YARD
T	TANGENT LENGTH
TC	TOP OF CURB
TLE	TEMPORARY LIMITED EASEMENT

INDEX OF TYPICAL SECTION AND DETAIL SHEETS

- PROJECT OVERVIEW
- TYPICAL SECTIONS
- CONSTRUCTION DETAILS
- CURB RAMP DETAILS
- PLAN DETAILS
- EROSION CONTROL PLAN
- STORM SEWER PLAN
- LIGHTING REMOVAL PLAN
- LIGHTING PLAN
- TRAFFIC CONTROL PLAN
- DETOUR PLAN
- ALIGNMENT PLAN

MUNICIPALITY

VILLAGE OF WEST MILWAUKEE - ADMINISTRATOR
KIM EGAN
4755 W. BELOIT RD
WEST MILWAUKEE, WI 53214
(414) 645-1530
KIM.EGAN@WESTMILWAUKEE.ORG

VILLAGE OF WEST MILWAUKEE - VILLAGE ENGINEER
LEN ROECKER, P.E., P.L.S.
16745 W. BLUEMOUND ROAD
BROOKFIELD, WI 53005-5938
(262) 317-3383
LEN.ROECKER@RASMITH.COM

DESIGN CONTACT

GRAEF
DOUG ROGAHN, P.E.
275 W. WISCONSIN AVENUE, SUITE 300
MILWAUKEE, WI 53203
(414) 266-9023
DOUG.ROGAHN@GRAEF-USA.COM

WisDOT CONTACT

WISCONSIN DEPT. OF TRANSPORTATION
MICHAEL BAIRD, P.E.
141 NW BARSTOW STREET
WAUKESHA, WI 53188
(262) 548-5918
MICHAEL.BAIRD@DOT.WI.GOV

DEPT. OF NATURAL RESOURCES

WISCONSIN DEPT. OF NATURAL RESOURCES
RYAN PAPPAS
1027 WEST ST PAUL AVENUE
MILWAUKEE, WI 53233
(414) 750-7495
RYAN.PAPPAS@WISCONSIN.GOV

MILWAUKEE COUNTY TRANSIT

MILWAUKEE COUNTY TRANSIT SYSTEM
DAVID LOCHER
1942 N. 17TH STREET
MILWAUKEE, WI 53205
(414) 343-1727
DLOCHER@MCTS.ORG

SEWRPC

SOUTHEAST WISCONSIN REGIONAL PLANNING COMMISSION
ROB MERRY
W239 N1812 ROCKWOOD DRIVE
PO BOX 1607
WAUKESHA, WI 53187-1607
(920) 912-1036
RMERRY@SEWRPC.ORG

OTHER

VILLAGE OF WEST MILWAUKEE - LIGHTING
JASON JOURDAN
4755 W. BELOIT RD
WEST MILWAUKEE, WI 53214
651-5890
JASON.JOURDAN@WESTMILWAUKEE.ORG

WEST ALLIS - WEST MILWAUKEE SCHOOL DISTRICT
STEVEN EICHMAN
1205 S. 70TH STREET, SUITE 513
WEST ALLIS, WI 53214
(650) 762-4716
EICHMANS@WAWMSD.ORG

UTILITIES

AT&T WISCONSIN
MR. NATHAN GIBERT
411 7TH STREET
RACINE, WI 53403
(262) 720-8235
NG952W@ATT.COM

CITY OF WEST ALLIS WATER DEPARTMENT
ROBERT HUTTER
7525 W GREENFIELD AVENUE
WEST ALLIS, WI 53214
(414) 302-8373
RHUTTER@WESTALLISWI.GOV

SPECTRUM
CHARLES BRASILE
1320 N. MARTIN LUTHER KING JR DRIVE
MILWAUKEE, WI 53212
(414) 908-4822
CHARLES.BRASILE@CHARTER.COM

TELEPORT COMMUNICATIONS AMERICA
TIMOTHY LAPOINTE
5101 THATCHER ROAD
DOWNERS GROVE, IL 60515
(281) 352-3631
TL0695@ATT.COM

VERIZON
RJ CICATELLO
15725 WEST RYERSON ROAD
NEW BERLIN, WI 53151
(262) 232-1323
RANDY.CICATELLO@VERIZON.COM

VILLAGE OF WEST MILWAUKEE - SEWER & WATER
JAMES STENZEL
4755 W. BELOIT RD
WEST MILWAUKEE, WI 53214
(414) 651-5893
JAMES.STENZEL@WESTMILWAUKEE.ORG

WE ENERGIES (GAS OPERATIONS)
CONSTRUCTION CONTACT
STEVE SCHECHER
500 S 116th STREET
WEST ALLIS, WI 53214
(414) 944-5639
STEVE.SCHECHER@WE-ENERGIES.COM

WE ENERGIES (ELECTRIC)
CONSTRUCTION CONTACT
WILLIAM COOK JR.
500 S 116th STREET
WEST ALLIS, WI 53214
(262) 758-6031
BILL.COOK@WE-ENERGIES.COM

DIGGERS HOTLINE
Dial **811** or (800)242-8511
www.DiggersHotline.com

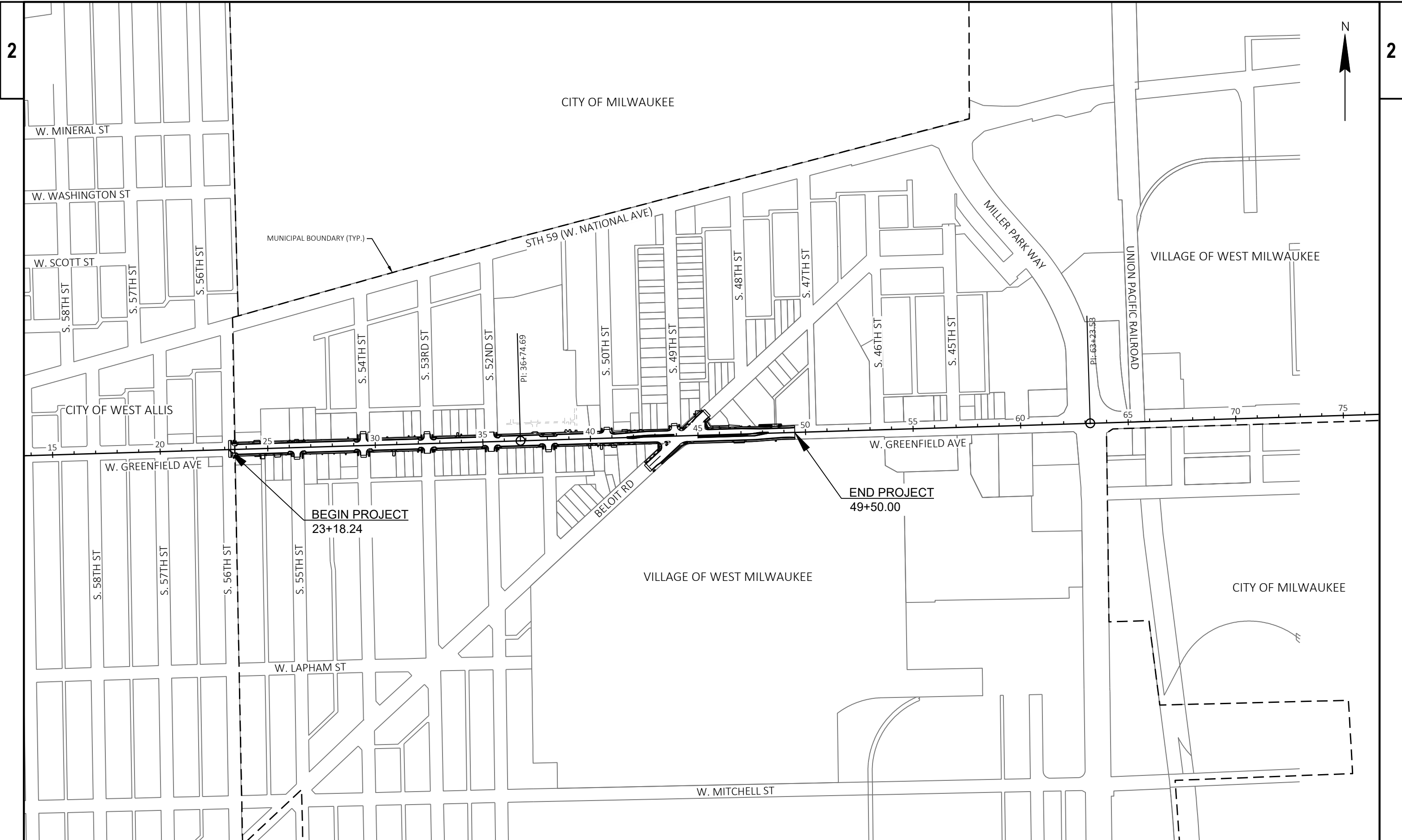

2

2

PROJECT NO: 2230-07-73

HWY: W. GREENFIELD AVENUE

COUNTY: MILWAUKEE

PROJECT OVERVIEW

SHEET

E

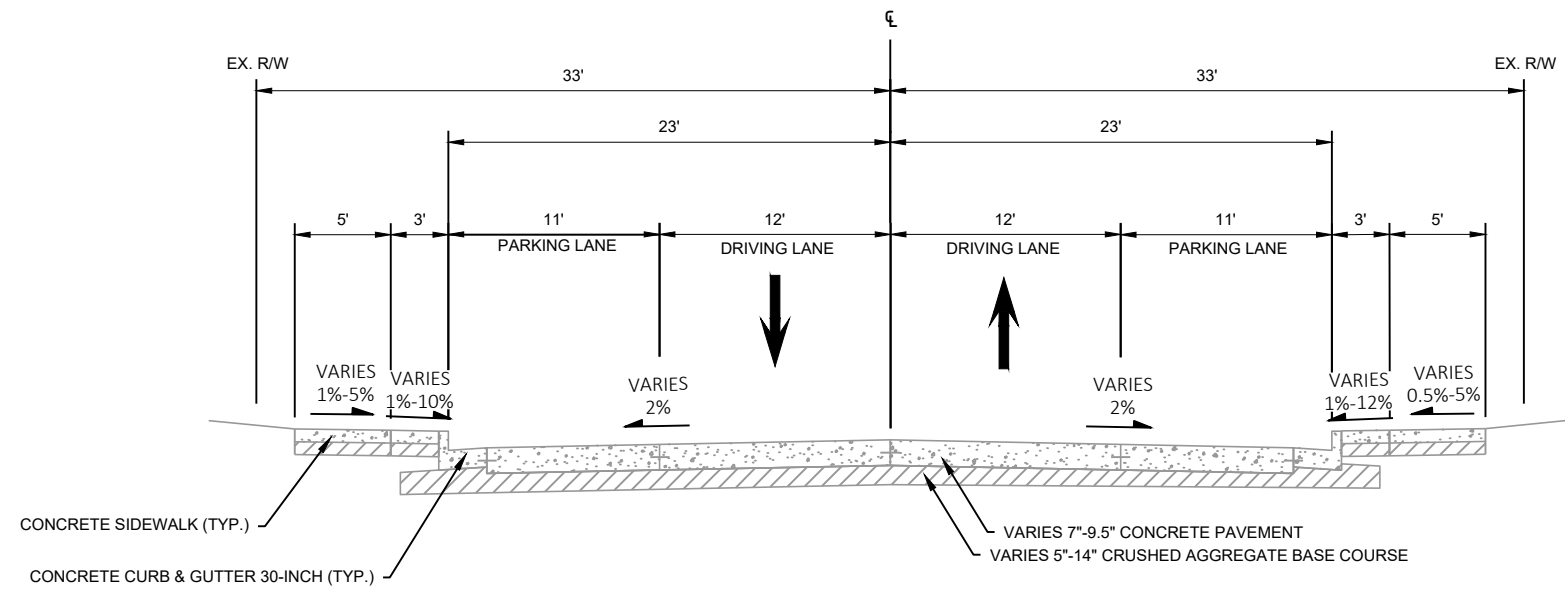

EXISTING TYPICAL SECTION

W. GREENFIELD AVENUE
STA. 23+46 TO STA. 44+25

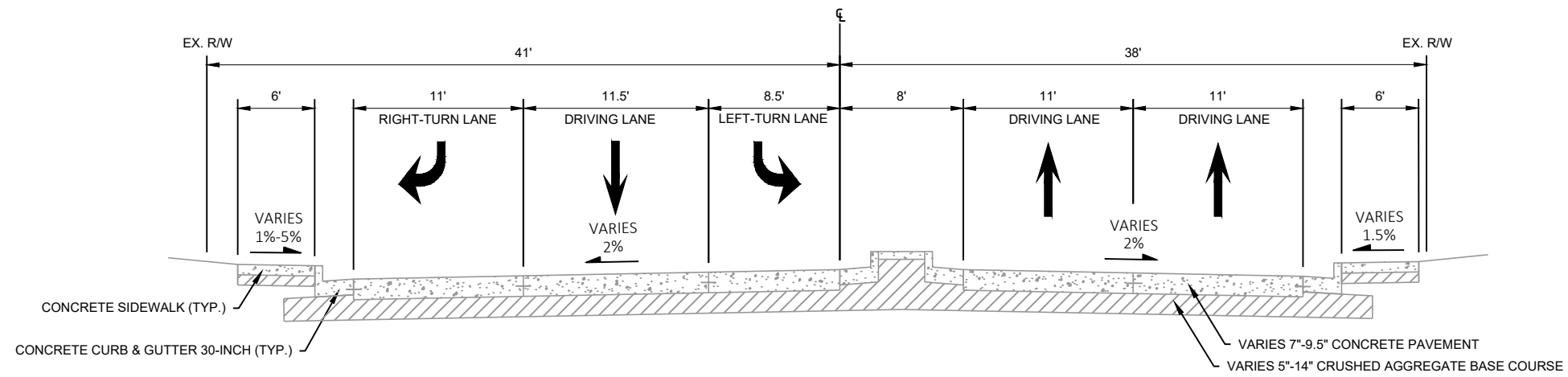

EXISTING TYPICAL SECTION

W. GREENFIELD AVENUE
STA. 44+25 TO STA. 47+50

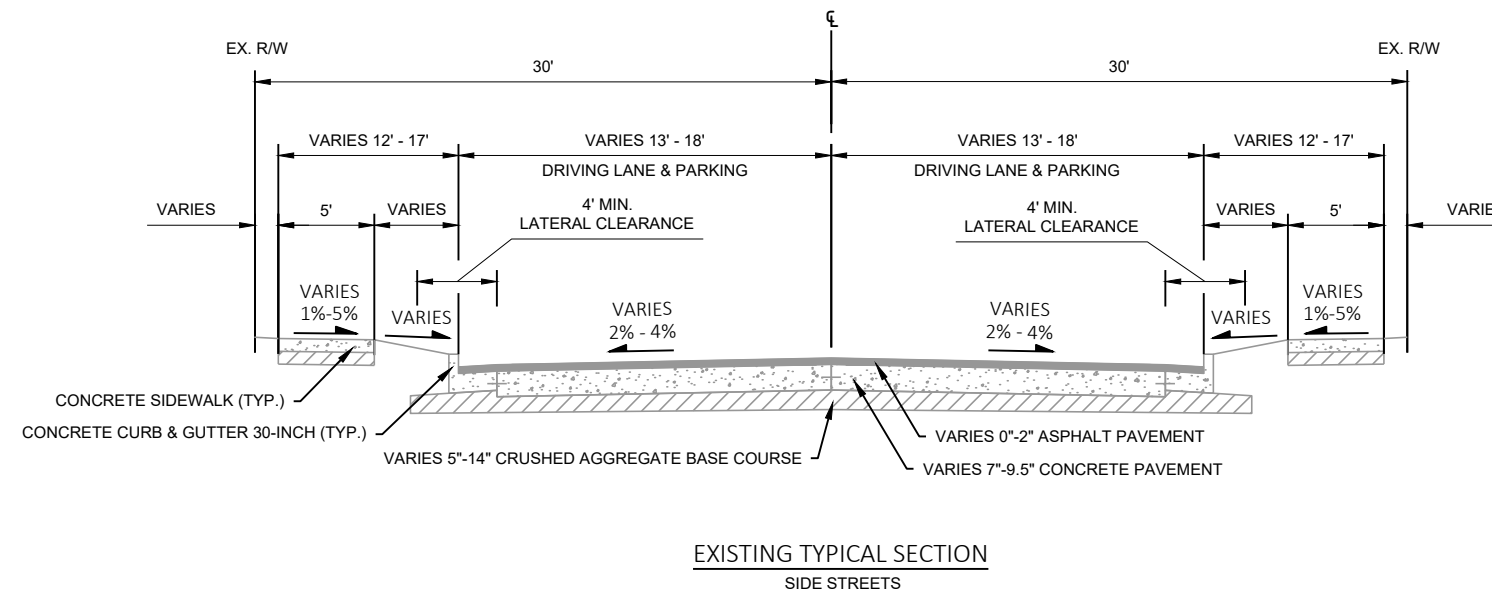
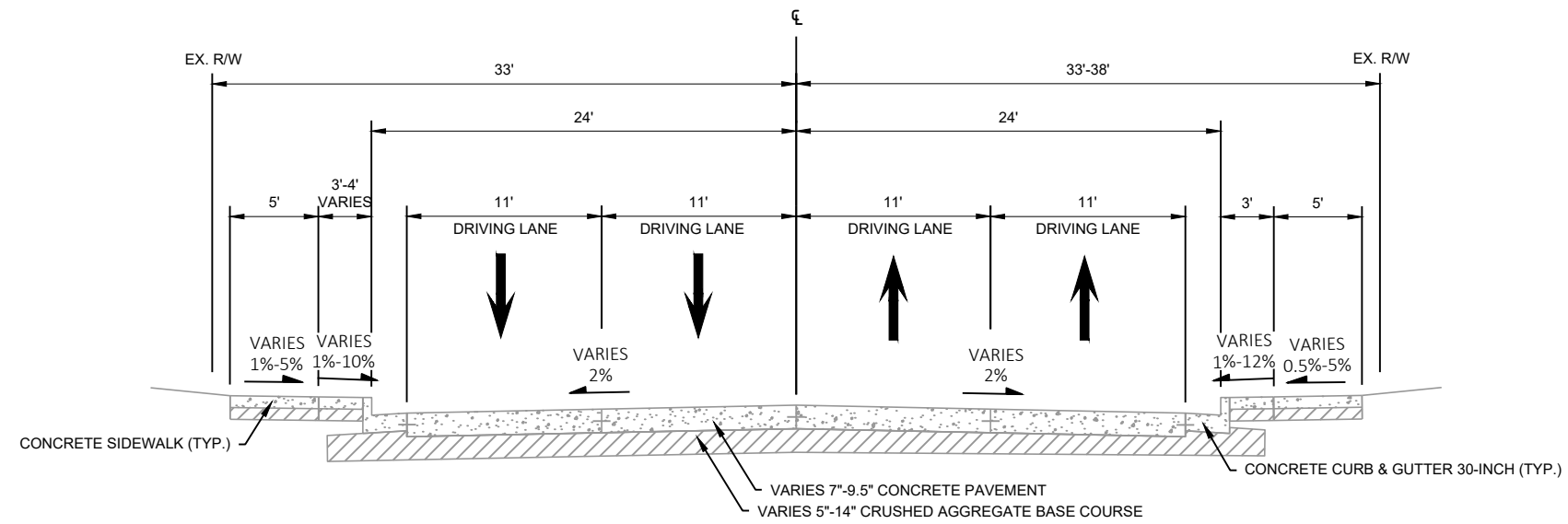

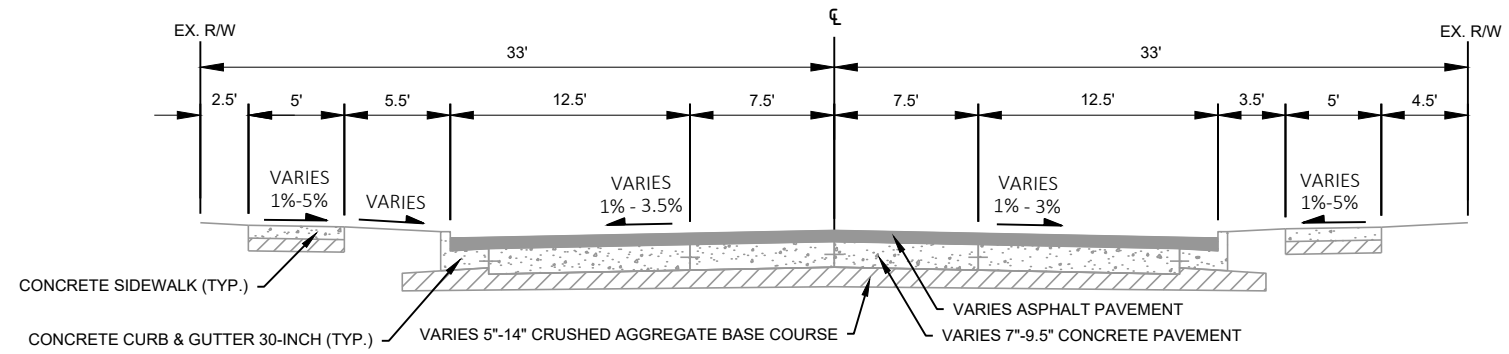

EXISTING TYPICAL SECTION
 W. BELOIT ROAD
 SOUTH OF W. GREENFIELD AVENUE
 STA. 503+75 TO STA. 506+00

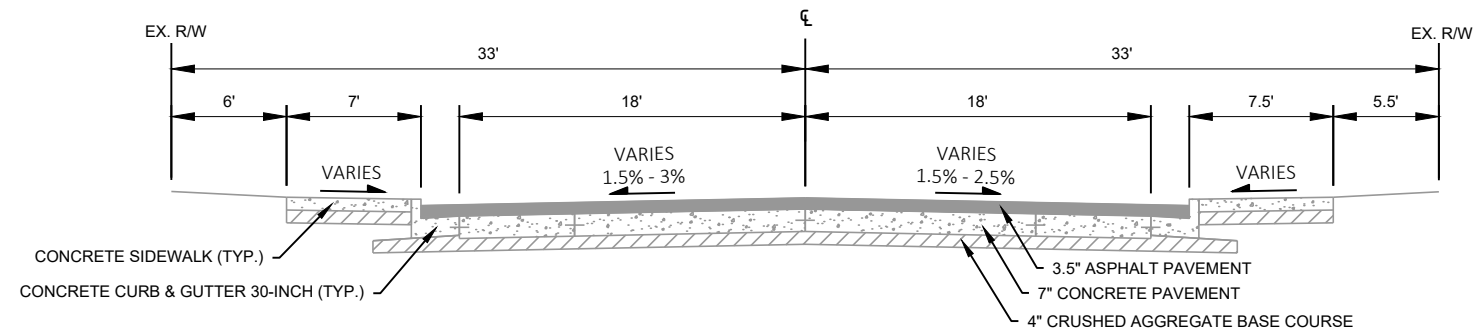

EXISTING TYPICAL SECTION
 W. BELOIT ROAD
 NORTH OF W. GREENFIELD AVENUE
 STA. 506+00 TO STA. 507+35

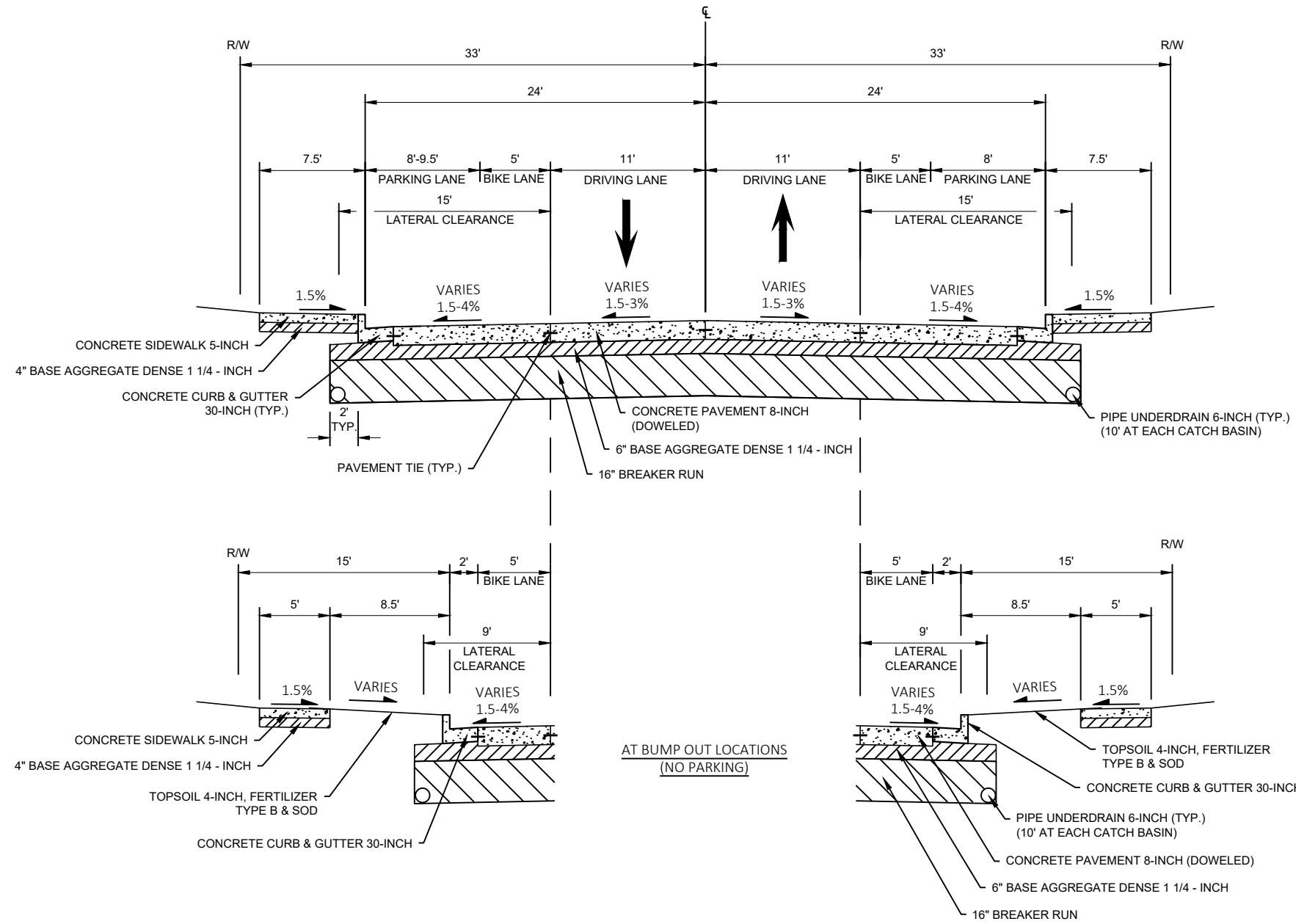

TYPICAL FINISHED SECTION

W. GREENFIELD AVENUE
STA. 23+46 TO STA. 40+90

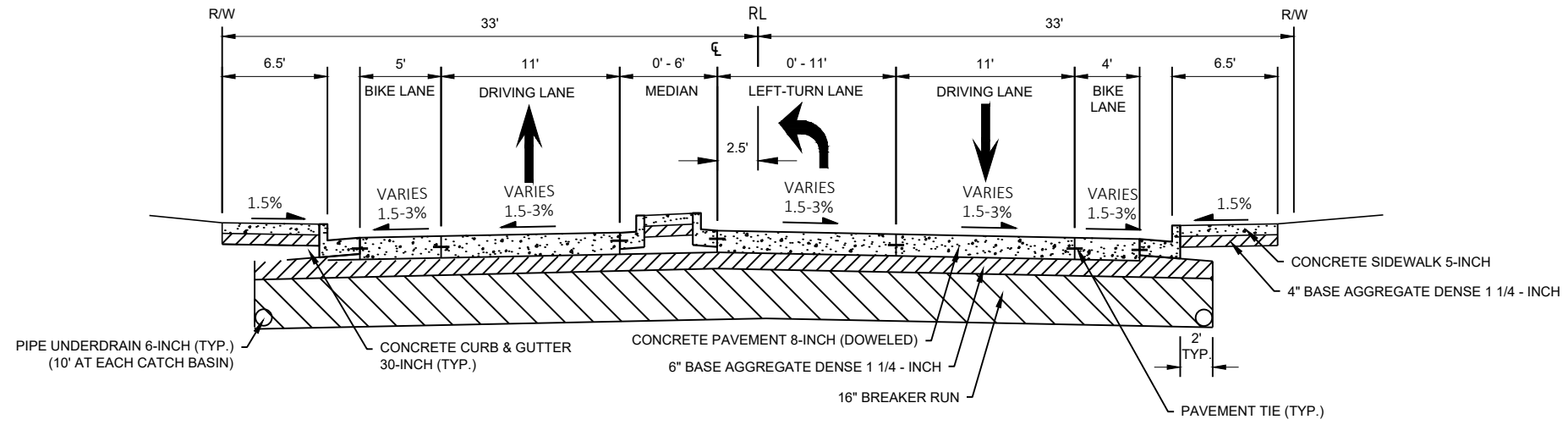

TYPICAL FINISHED SECTION

W. GREENFIELD AVENUE
STA. 40+90 TO STA. 44+25

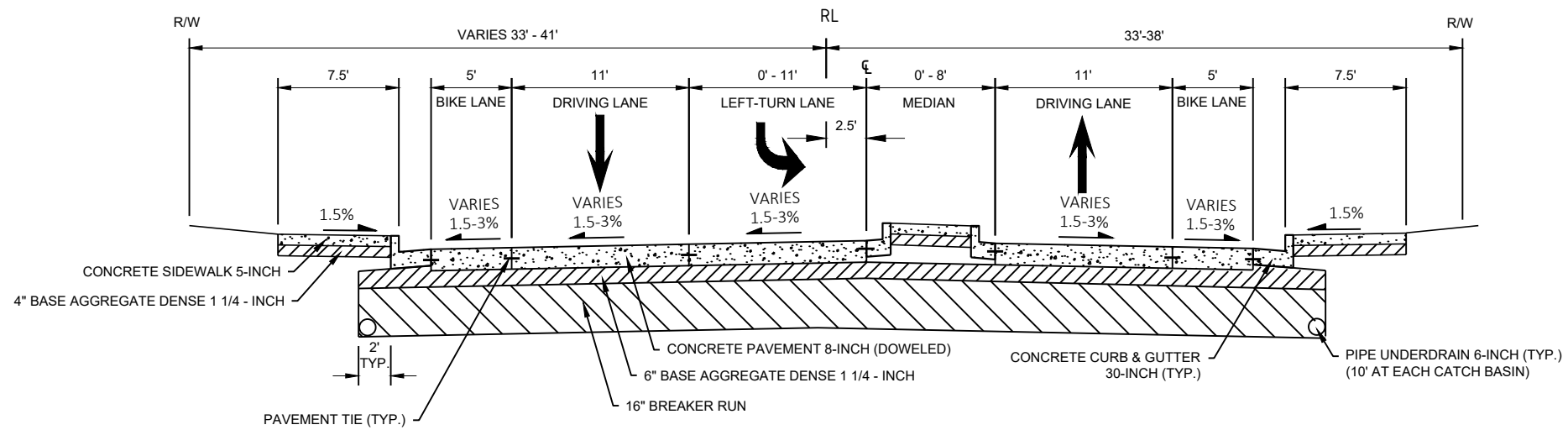

TYPICAL FINISHED SECTION

W. GREENFIELD AVENUE
STA. 44+25 TO STA. 48+61

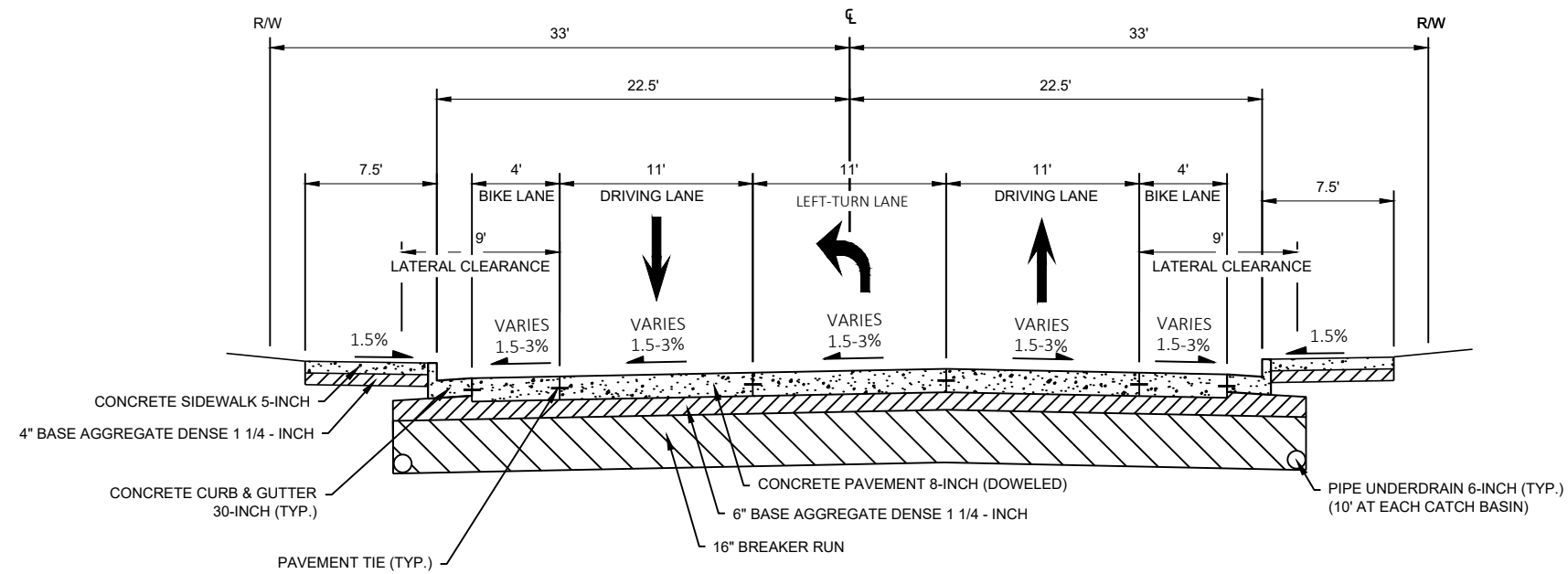

TYPICAL FINISHED SECTION
 W. GREENFIELD AVENUE
 STA. 48+61 TO STA. 49+50

DRIVEWAY ENTRANCE DETAIL WITH SIDEWALK, CURB & GUTTER

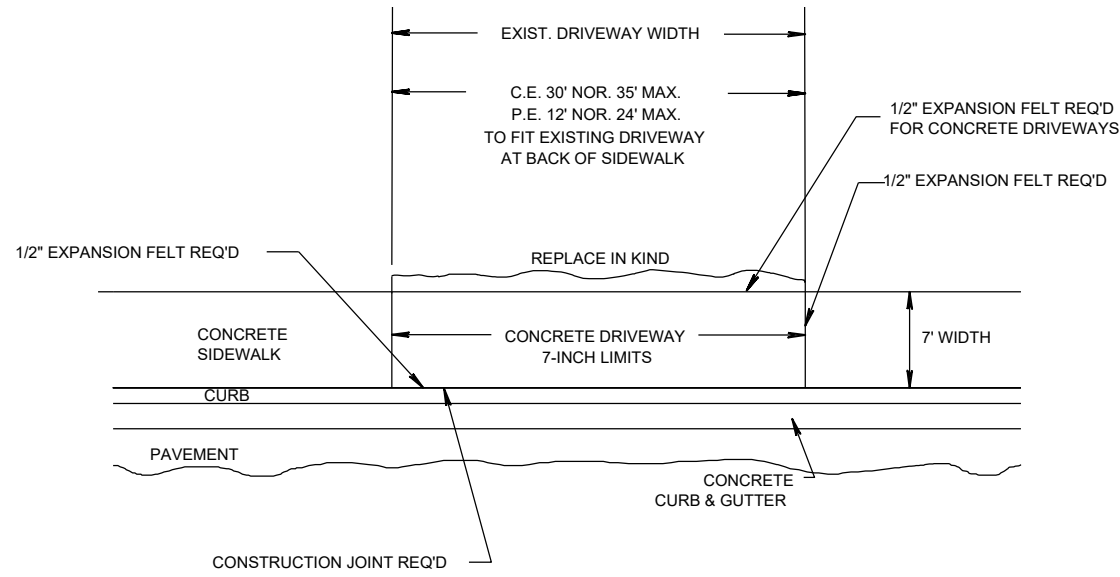

PLAN VIEW

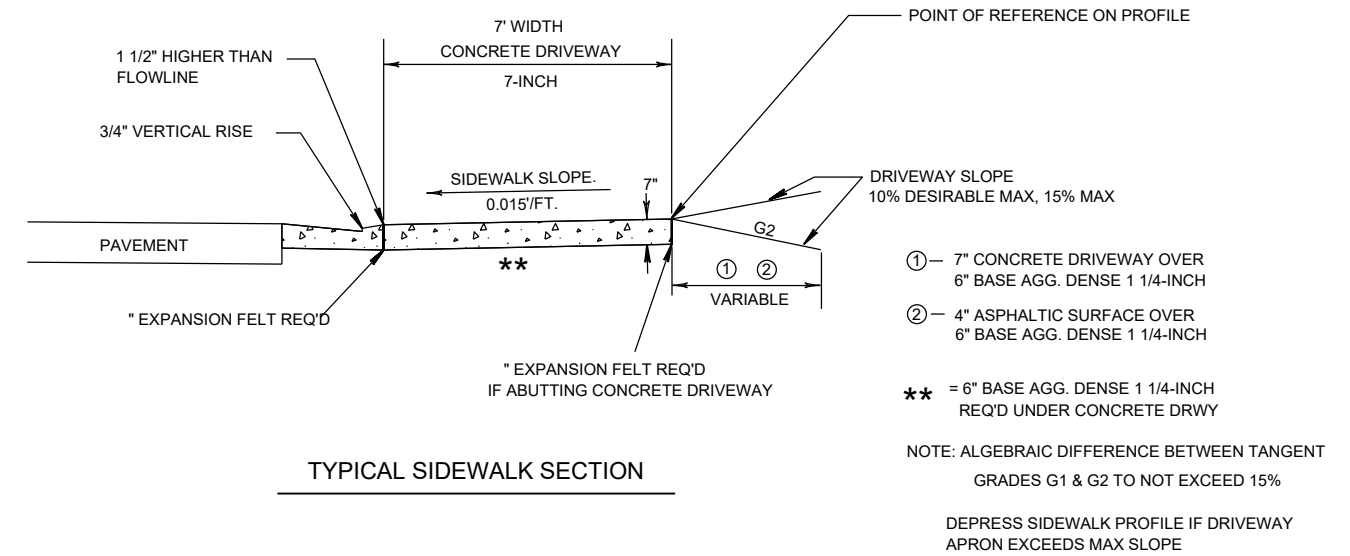

TYPICAL SIDEWALK SECTION

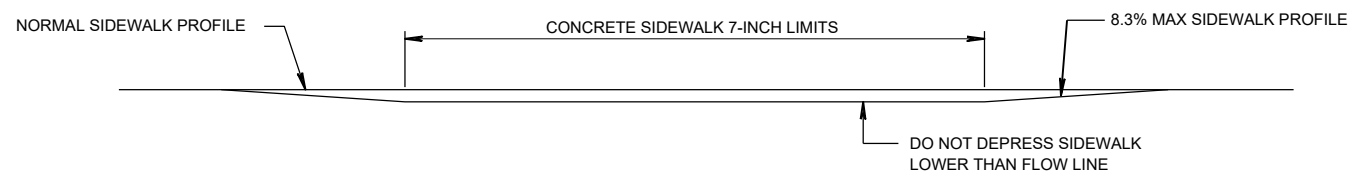

DEPRESSED SIDEWALK PROFILE DETAIL

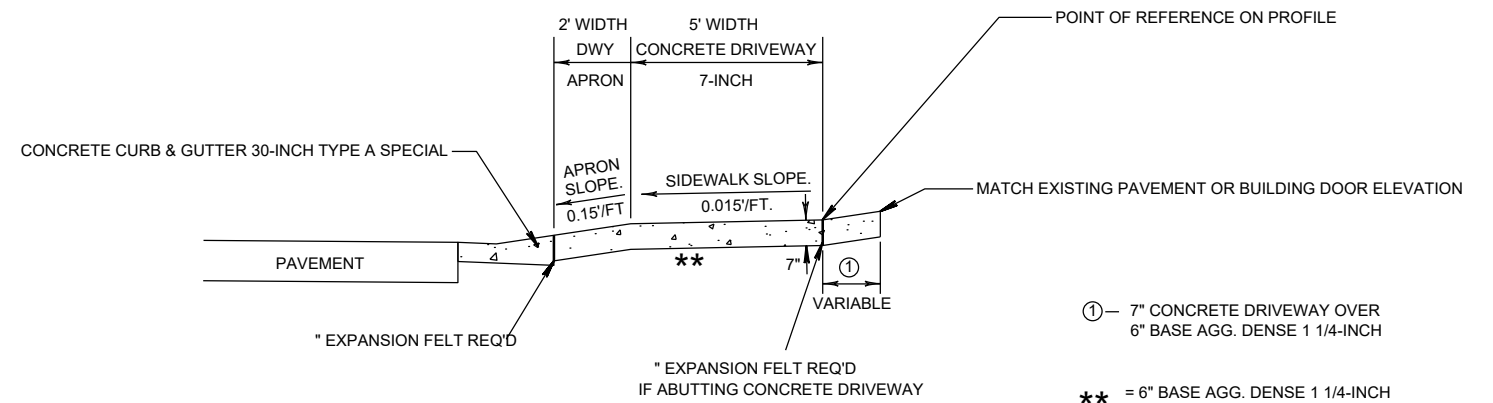

DRIVEWAY SECTION STA 40+96 TO STA 41+38 RT

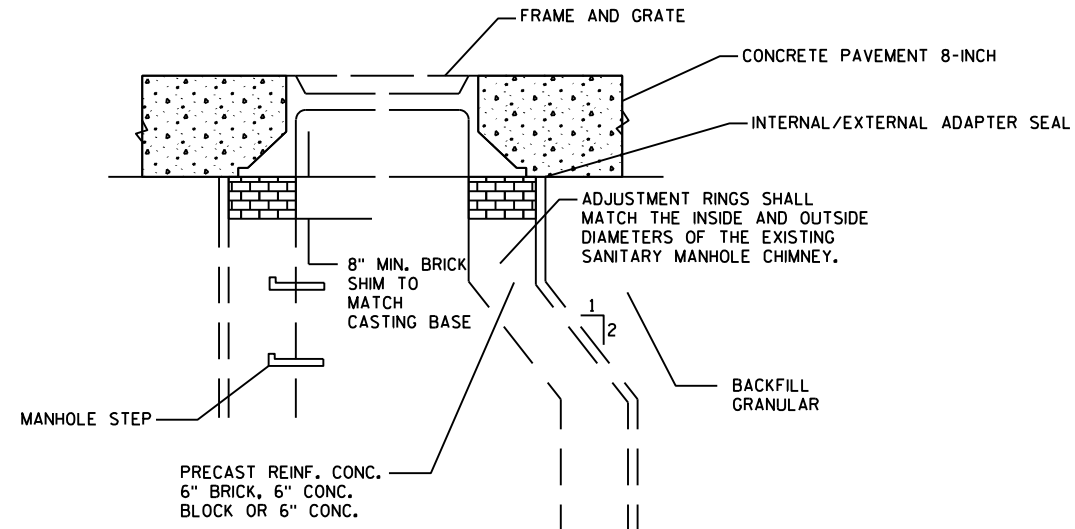

THE WORK INCLUDES REPAIRING AND ADJUSTING SANITARY MANHOLE CHIMNEY, THE INSTALLATION OF MANHOLE SEAL AND THE INSTALLATION OF NEW FRAME AND GRATE.

ADJUSTING/RECONSTRUCTING SANITARY MANHOLE

NOT TO SCALE

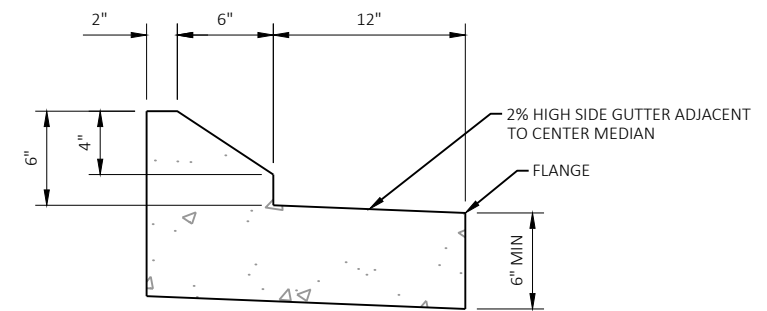

CONCRETE CURB & GUTTER 18-INCH TYPE G

STA. 46+65 TO STA. 48+25 (IN CENTER MEDIAN)
(PAID AS CONCRETE CURB & GUTTER 18-INCH TYPE A)

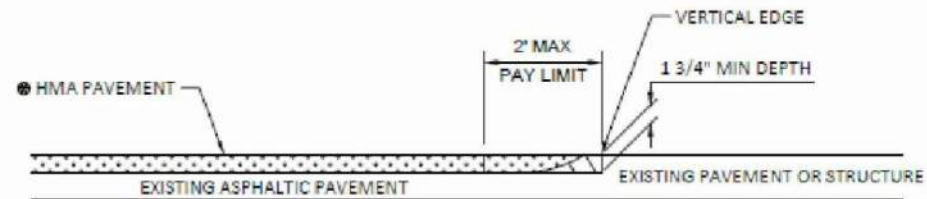

SEE TYPICAL CROSS SECTION FOR PAVEMENT TYPE AND THICKNESS OF INDIVIDUAL LAYERS

- REMOVING ASPHALTIC SURFACE, MILLING
- REMOVE ASPHALTIC SURFACE WEDGE AT BUTT JOINT TO CREATE VERTICAL EDGE

203

BUTT JOINT DETAIL FOR ASPHALTIC PAVEMENTS (NO PROFILE CHANGE)

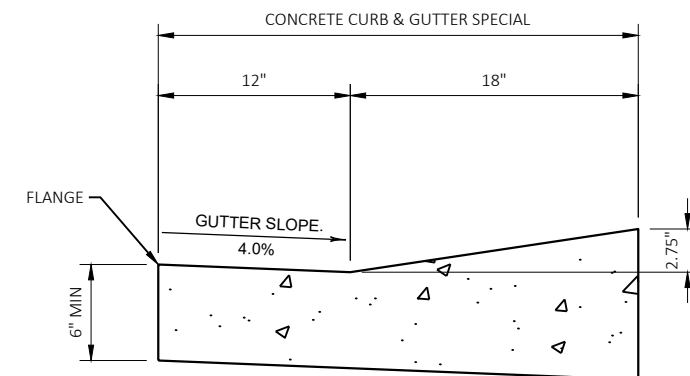

CONCRETE CURB & GUTTER 30-INCH TYPE A SPECIAL

STA. 40+96 TO STA. 41+38 RT

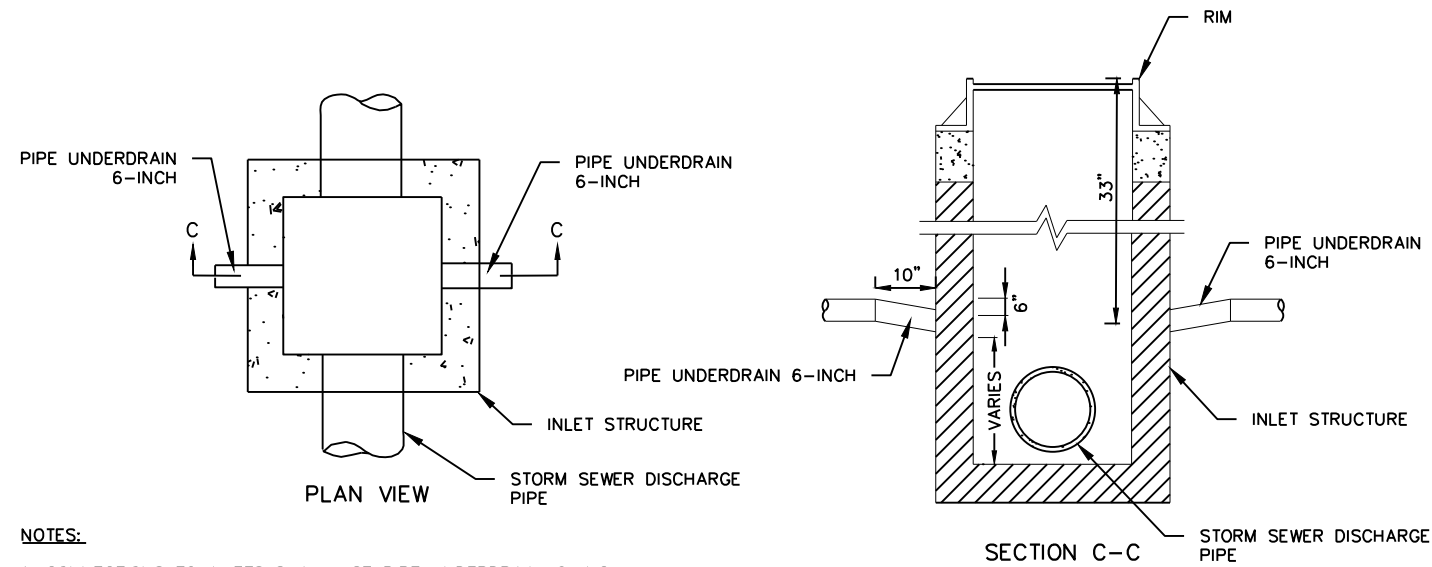

- NOTES:**
1. CONNECTIONS TO INLETS SHALL USE PIPE UNDERDRAIN, 6-INCH
 2. PROVIDE 6" DIA. OPENINGS FOR UNDERDRAIN PIPE A MINIMUM OF 33" BELOW THE RIM ELEVATION. CORE INTO EXISTING INLETS TO REMAIN.
 3. SEE MISCELLANEOUS QUANTITIES AND STORM SEWER PLANS FOR PIPE UNDERDRAIN LOCATIONS.
 4. PIPE UNDERDRAIN ONLY REQUIRED ON HIGH SIDE OF INLET IN SLOPED CONDITION.
 5. PIPE UNDERDRAIN REQUIRED ON BOTH SIDES OF INLET IN SAG CONDITION.

UNDERDRAIN OUTFALL AT INLET

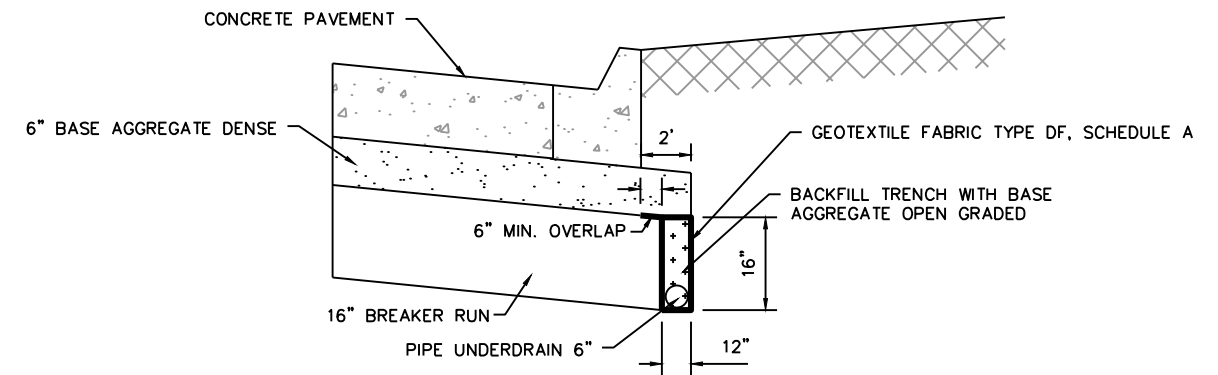
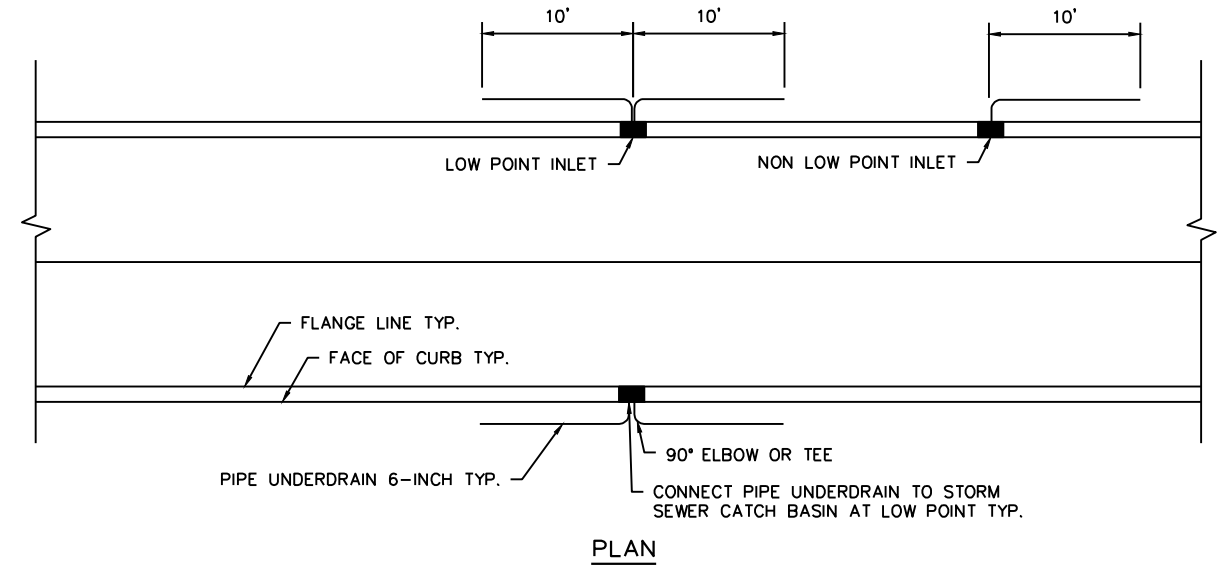

UNDERDRAIN TRENCH DETAIL

- 10' EACH SIDE OF INLET AT LOW POINTS.
- 10' ON HIGH SIDE OF INLET AT ALL OTHER INLETS
- CONNECT PIPE UNDERDRAIN TO INLETS

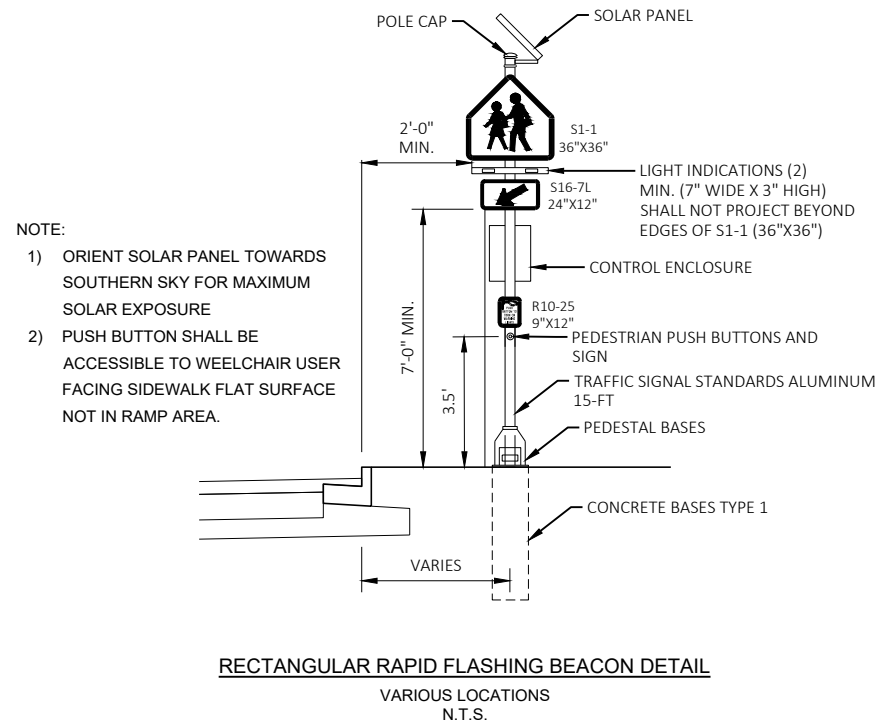

RECTANGULAR RAPID FLASHING BEACON DETAIL
VARIOUS LOCATIONS
N.T.S.

- NOTE:
- 1) ORIENT SOLAR PANEL TOWARDS SOUTHERN SKY FOR MAXIMUM SOLAR EXPOSURE
 - 2) PUSH BUTTON SHALL BE ACCESSIBLE TO WHEELCHAIR USER FACING SIDEWALK FLAT SURFACE NOT IN RAMP AREA.

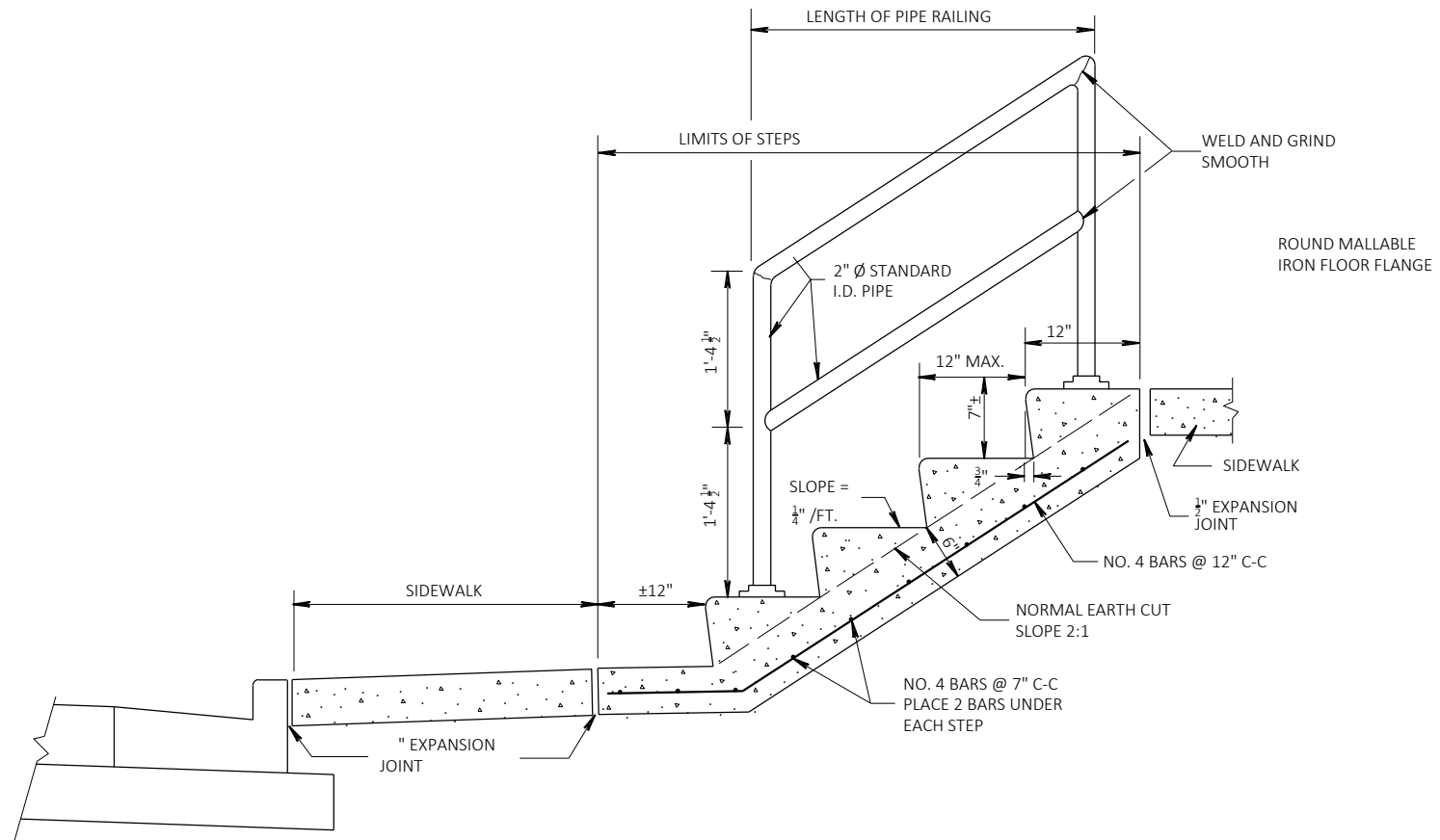

CONCRETE STEPS DETAIL

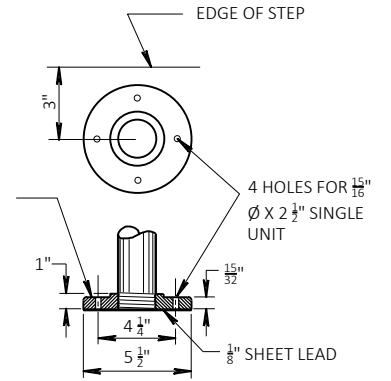

FLANGE DETAIL

- NOTE:
- THE EXACT LOCATION, WIDTHS, & NUMBER OF STEPS TO BE DETERMINED BY THE ENGINEER IN THE FIELD.
 - STEEL REINFORCEMENT AND PIPE RAILING NOT REQUIRED ON STEPS WITH 2 RISERS OR LESS.
 - MINIMUM WIDTH OF STEP EQUALS 4 FEET.
 - RAILING TO BE PLACED ON LEFT ASCENDING SIDE OF STEPS ONLY.

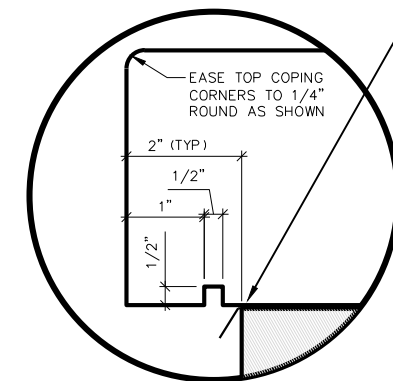
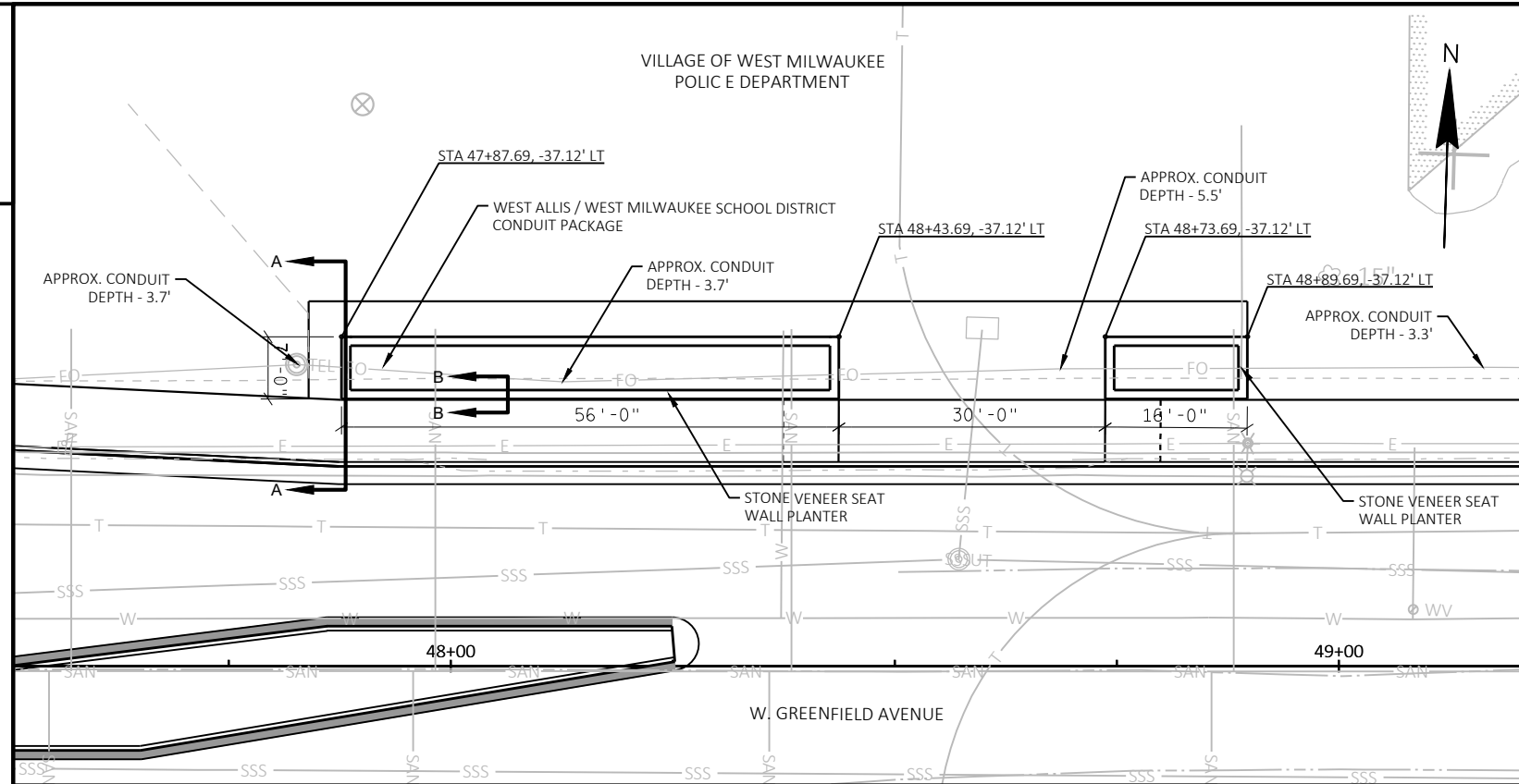

DRIP EDGE ENLARGEMENT DETAIL

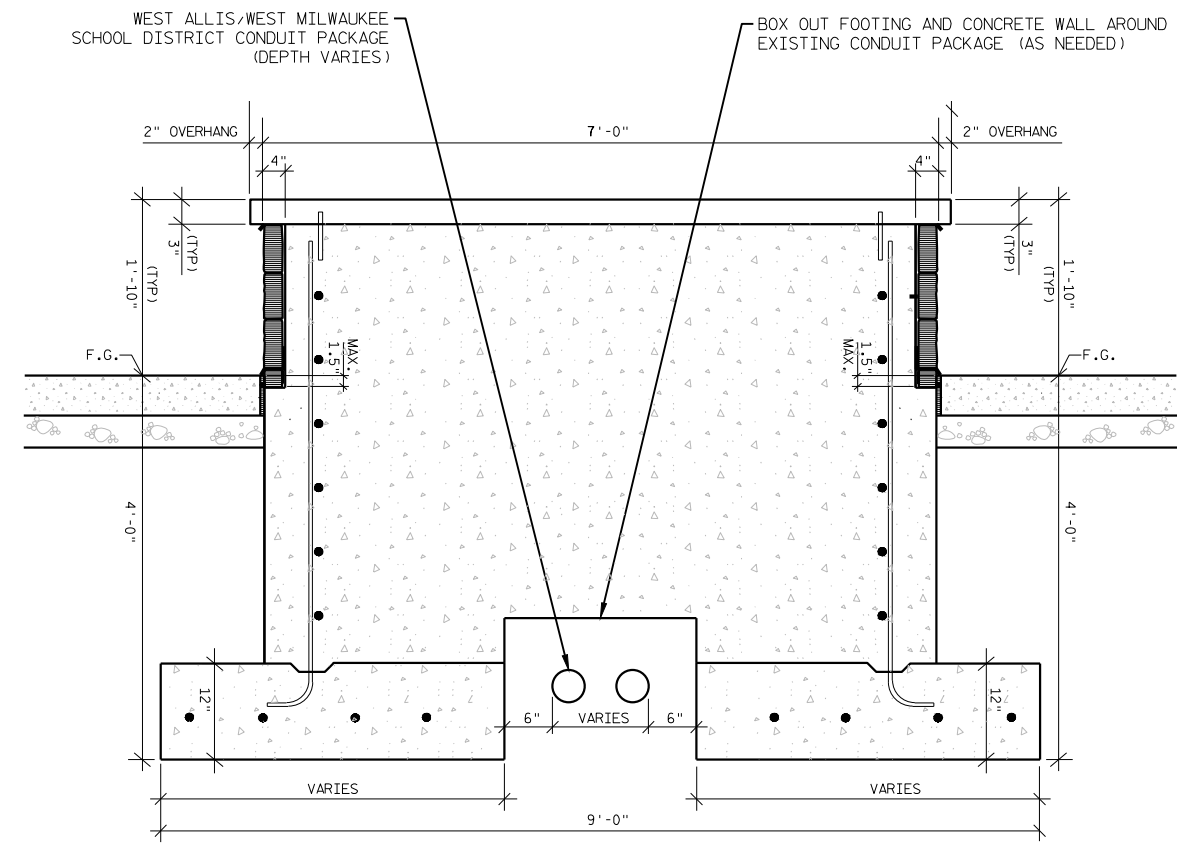



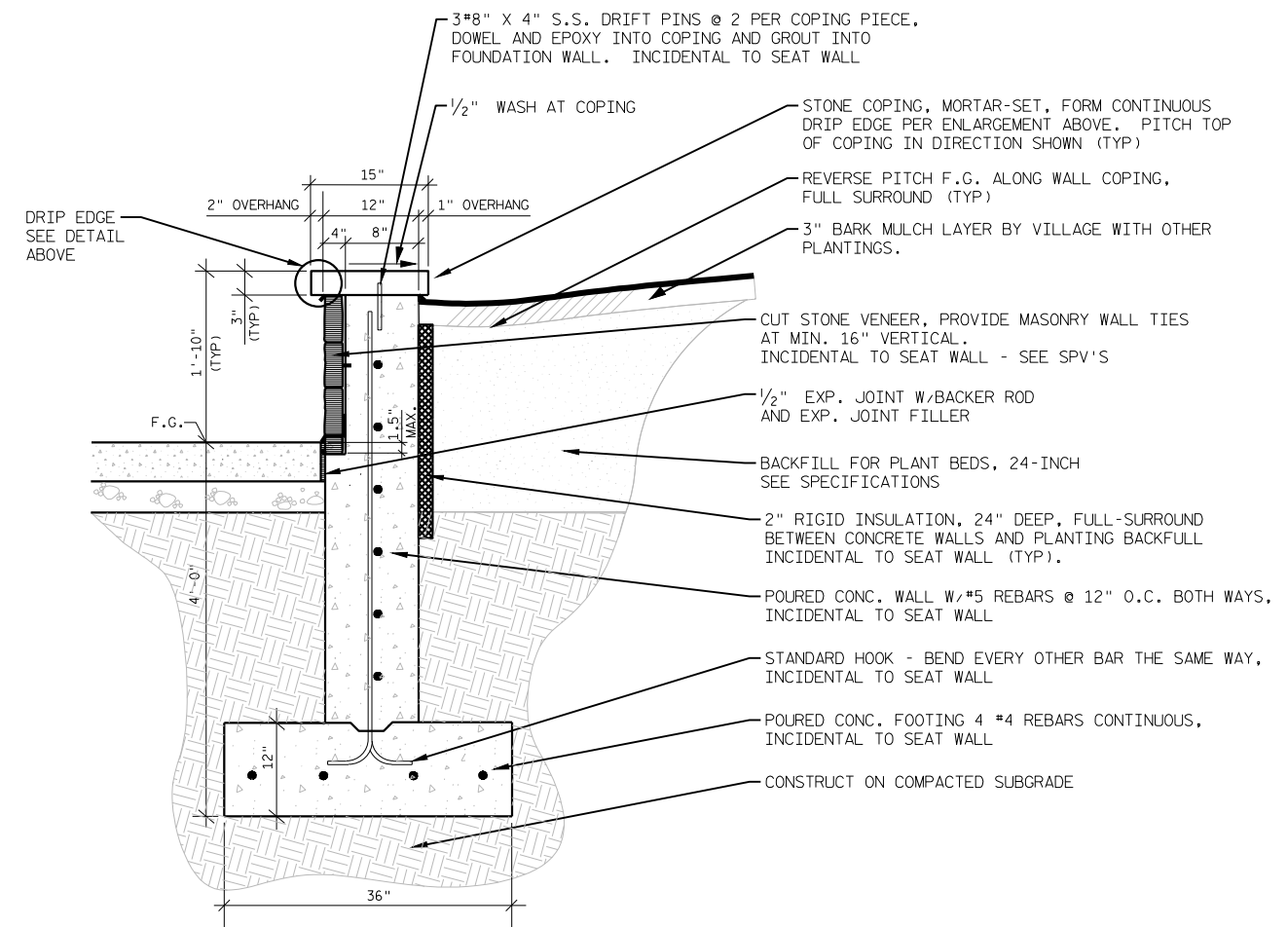





SECTION A-A



SECTION B-B

STONE VENEER SEAT WALL PLANTER

LEGEND



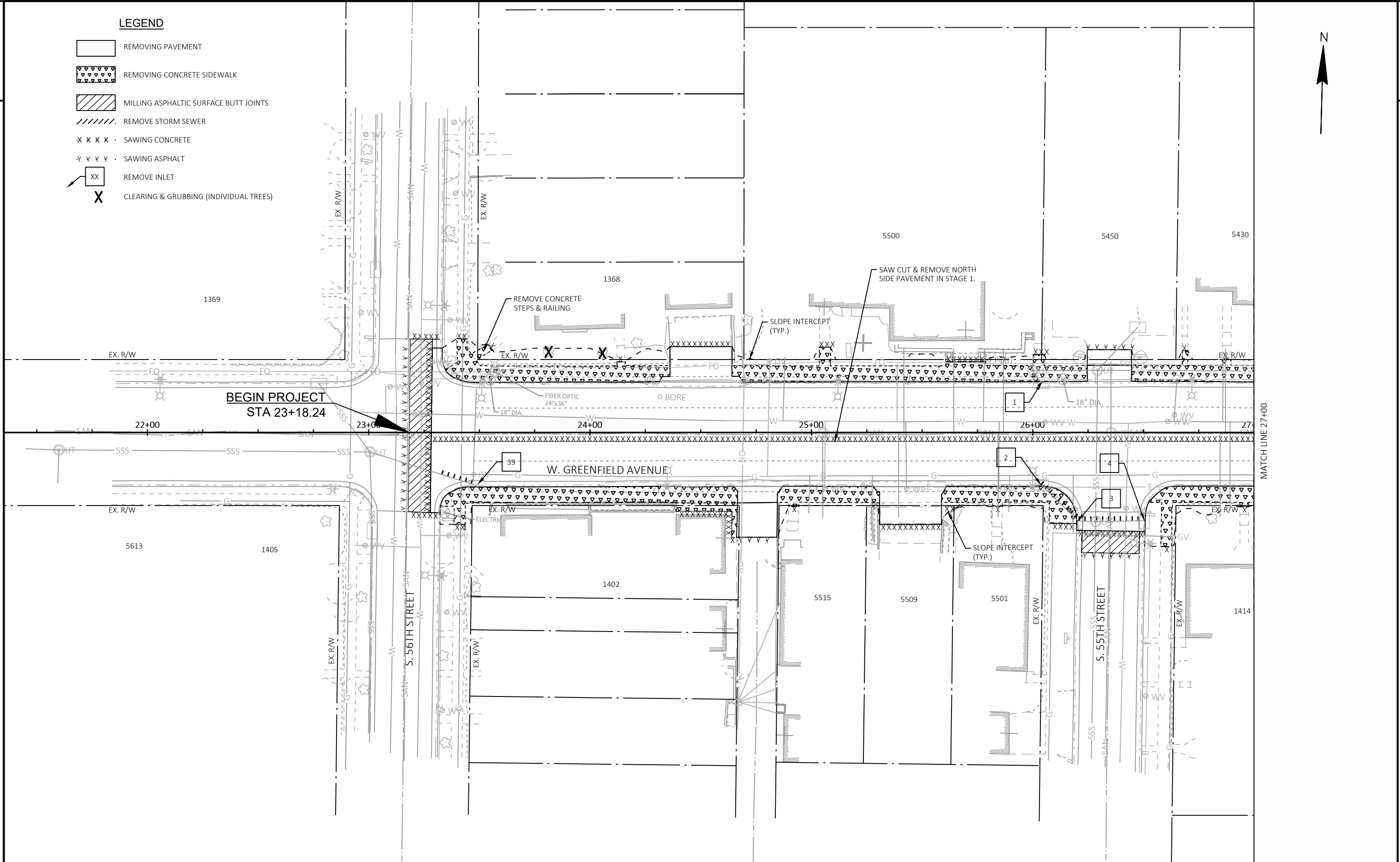



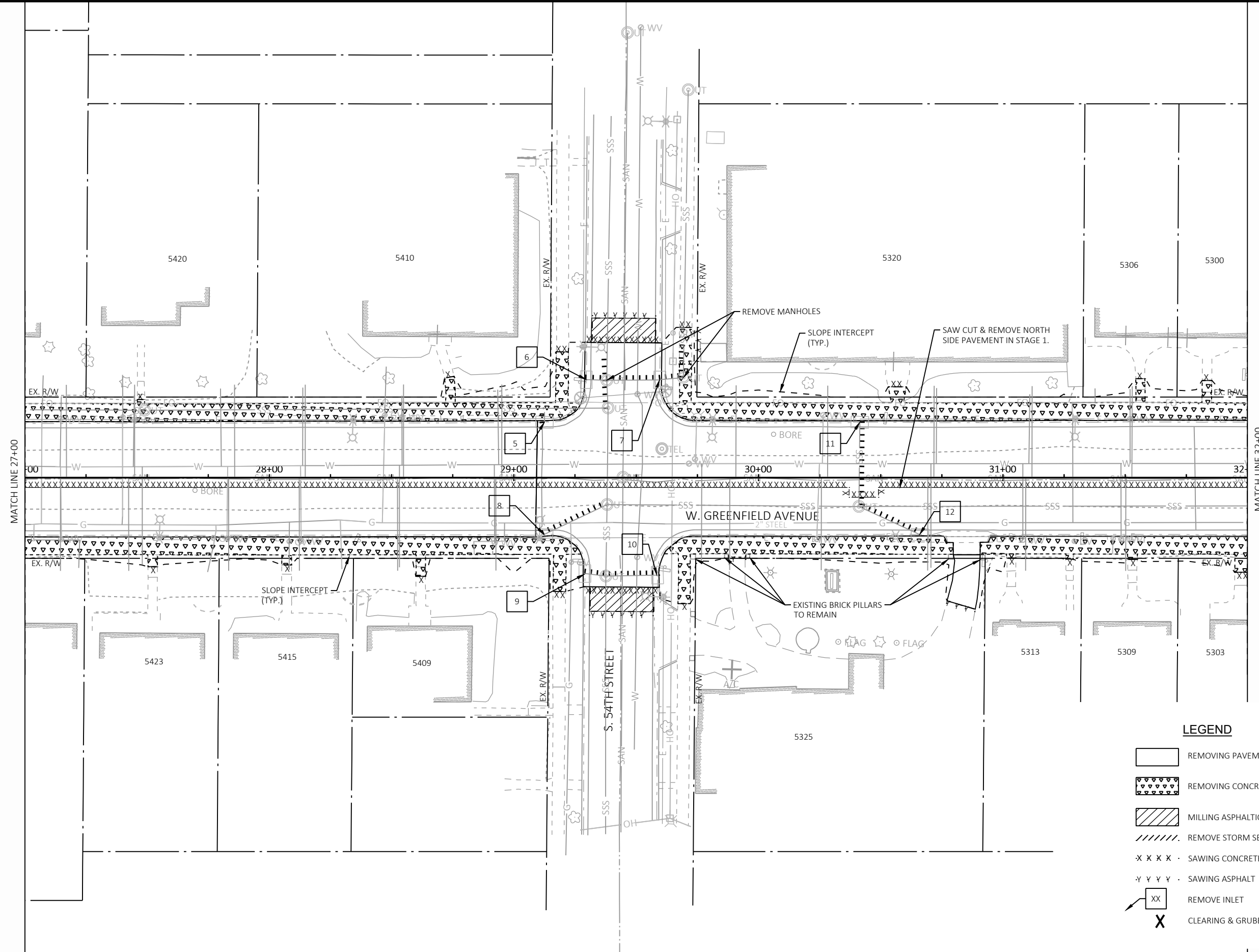

-  REMOVING PAVEMENT
-  REMOVING CONCRETE SIDEWALK
-  MILLING ASPHALTIC SURFACE BUTT JOINTS
-  REMOVE STORM SEWER
-  SAWING CONCRETE
-  SAWING ASPHALT
-  REMOVE INLET
-  CLEARING & GRUBBING (INDIVIDUAL TREES)



PROJECT NO: 2230-07-73	HWY: W. GREENFIELD AVENUE	COUNTY: MILWAUKEE	REMOVAL PLAN	SHEET	E
------------------------	---------------------------	-------------------	--------------	-------	----------



LEGEND

-  REMOVING PAVEMENT
-  REMOVING CONCRETE SIDEWALK
-  MILLING ASPHALTIC SURFACE BUTT JOINTS
-  REMOVE STORM SEWER
-  SAWING CONCRETE
-  SAWING ASPHALT
-  REMOVE INLET
-  CLEARING & GRUBBING (INDIVIDUAL TREES)

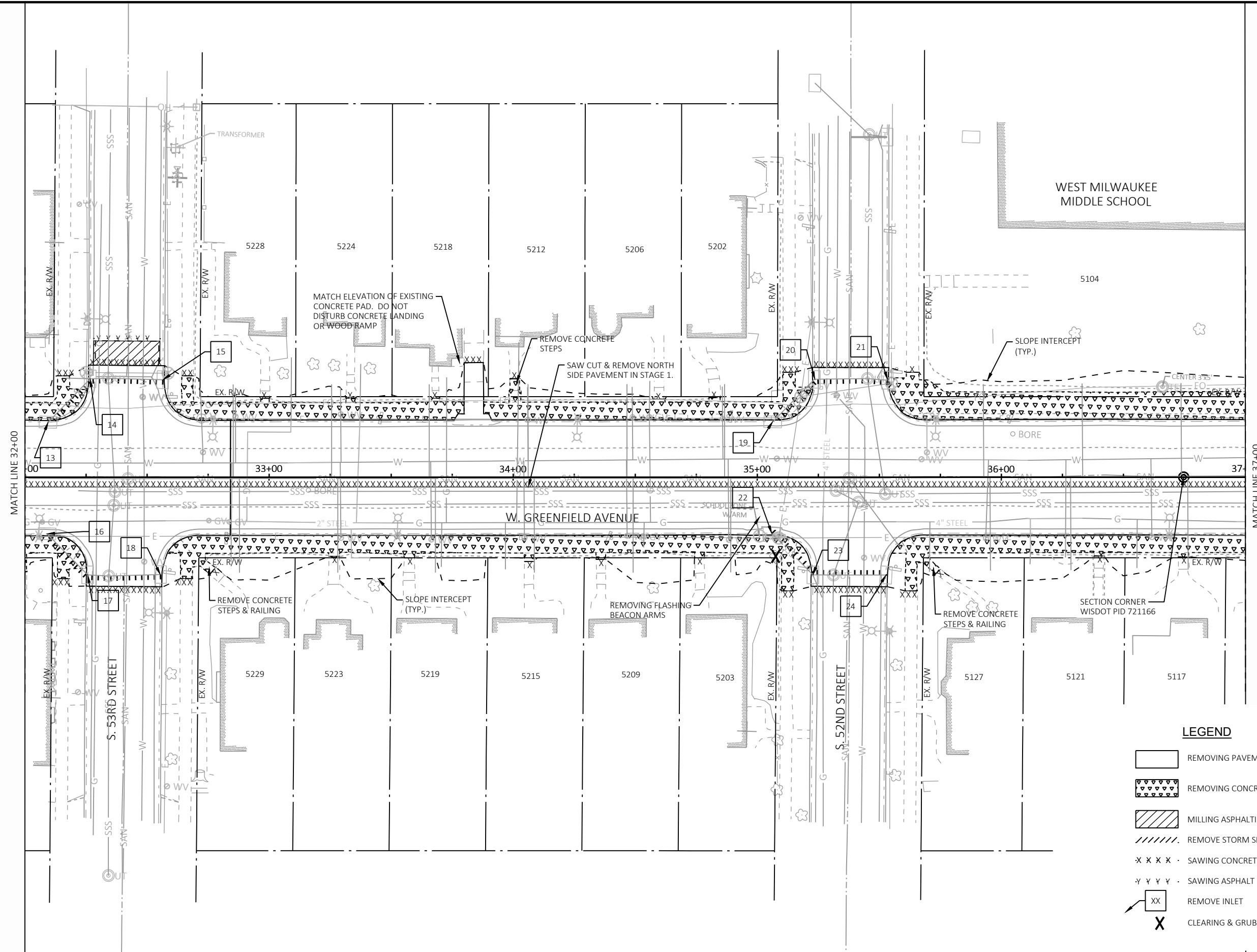





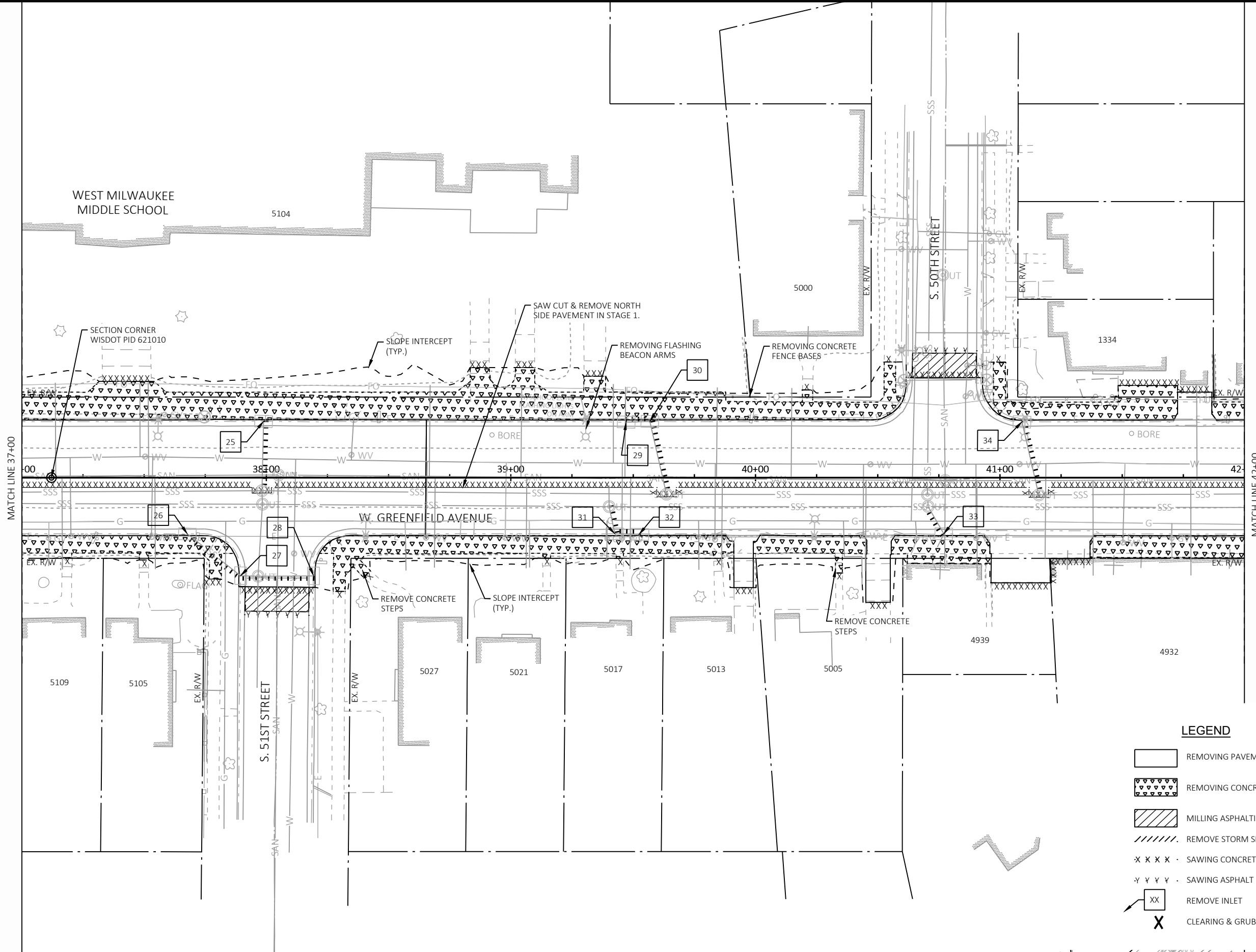



LEGEND

	REMOVING PAVEMENT
	REMOVING CONCRETE SIDEWALK
	MILLING ASPHALTIC SURFACE BUTT JOINTS
	REMOVE STORM SEWER
	SAWING CONCRETE
	SAWING ASPHALT
	REMOVE INLET
	CLEARING & GRUBBING (INDIVIDUAL TREES)



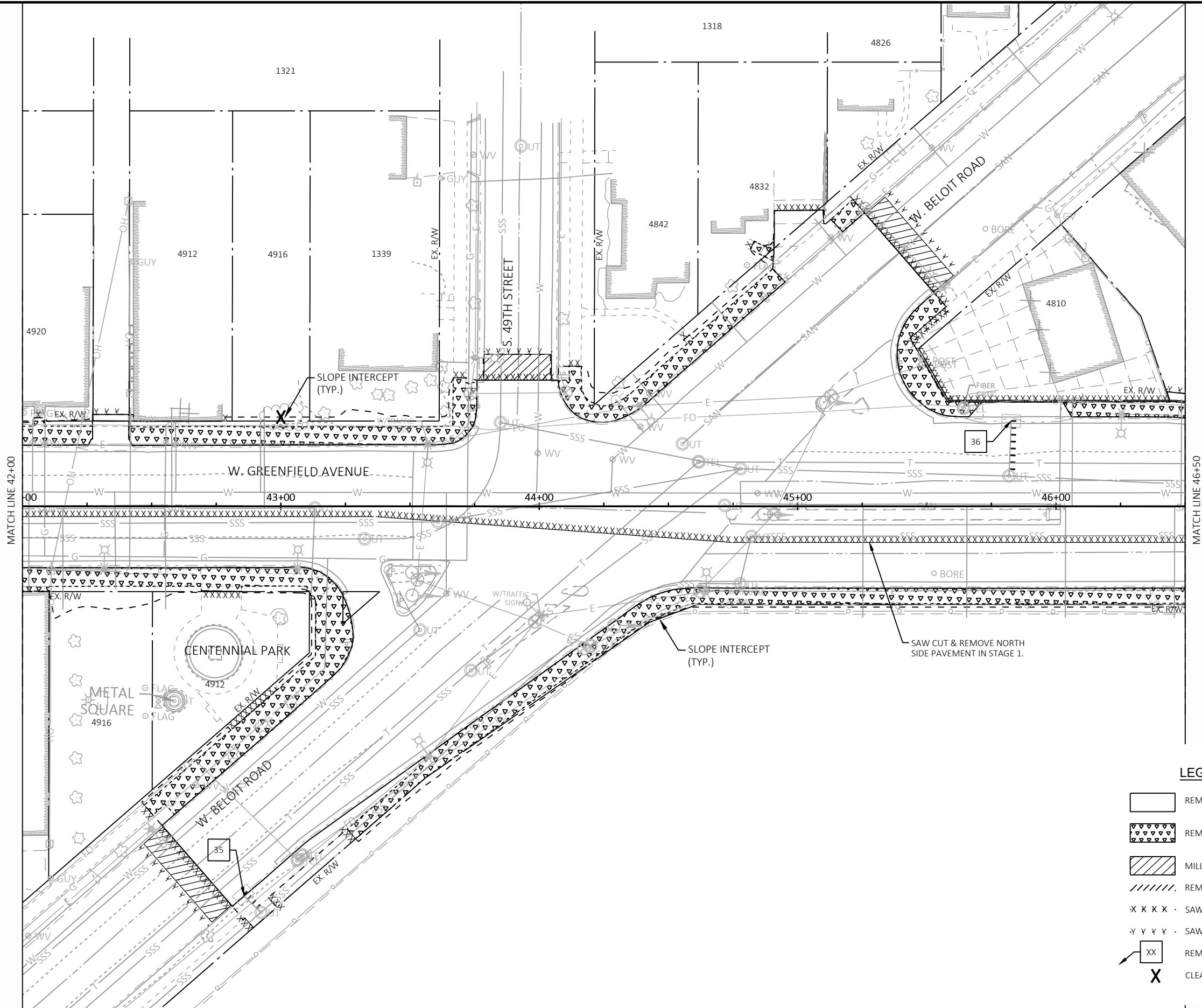

LEGEND

-  REMOVING PAVEMENT
-  REMOVING CONCRETE SIDEWALK
-  MILLING ASPHALTIC SURFACE BUTT JOINTS
-  REMOVE STORM SEWER
-  SAWING CONCRETE
-  SAWING ASPHALT
-  REMOVE INLET
-  CLEARING & GRUBBING (INDIVIDUAL TREES)



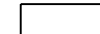
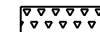
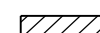
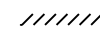
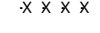
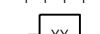



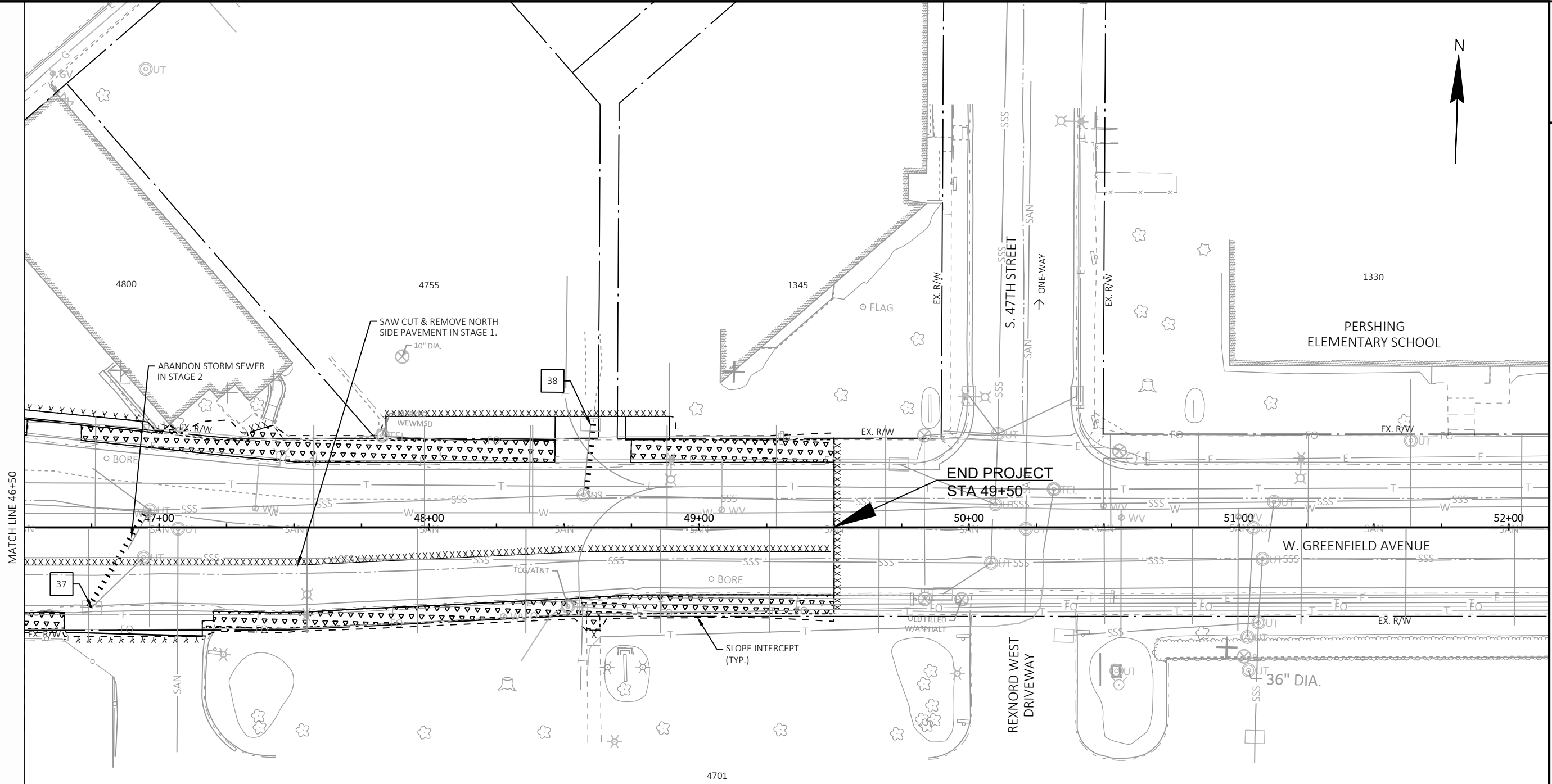



LEGEND

-  REMOVING PAVEMENT
-  REMOVING CONCRETE SIDEWALK
-  MILLING ASPHALTIC SURFACE BUTT JOINTS
-  REMOVE STORM SEWER
-  SAWING CONCRETE
-  SAWING ASPHALT
-  REMOVE INLET
-  CLEARING & GRUBBING (INDIVIDUAL TREES)











MATCH LINE 46+50

LEGEND

-  REMOVING PAVEMENT
-  REMOVING CONCRETE SIDEWALK
-  MILLING ASPHALTIC SURFACE BUTT JOINTS
-  REMOVE STORM SEWER
-  SAWING CONCRETE
-  SAWING ASPHALT
-  REMOVE INLET
-  CLEARING & GRUBBING (INDIVIDUAL TREES)



LEGEND

-  CONCRETE CURB AND GUTTER
TYPE
SIZE (INCHES)
-  CONCRETE PAVEMENT, 8-INCH OVER
BASE AGGREGATE DENSE 1-3/4 INCH, 6 INCHES OVER
BREAKER RUN 16 INCHES
-  2-INCH MILL AND 2-INCH HMA OVERLAY
-  CONCRETE SIDEWALK 5-INCH OVER
BASE AGGREGATE DENSE 1-3/4 INCH, 4 INCHES
-  CONCRETE DRIVEWAY 7-INCHES OVER
BASE AGGREGATE DENSE 1-3/4 INCH, 6 INCHES
-  ASPHALTIC SURFACE DRIVEWAYS
AND FIELD ENTRANCES
-  CONCRETE MEDIAN SLOPED NOSE
-  CURB RAMP
TYPE
-  HIGH SIDE CURB AND GUTTER

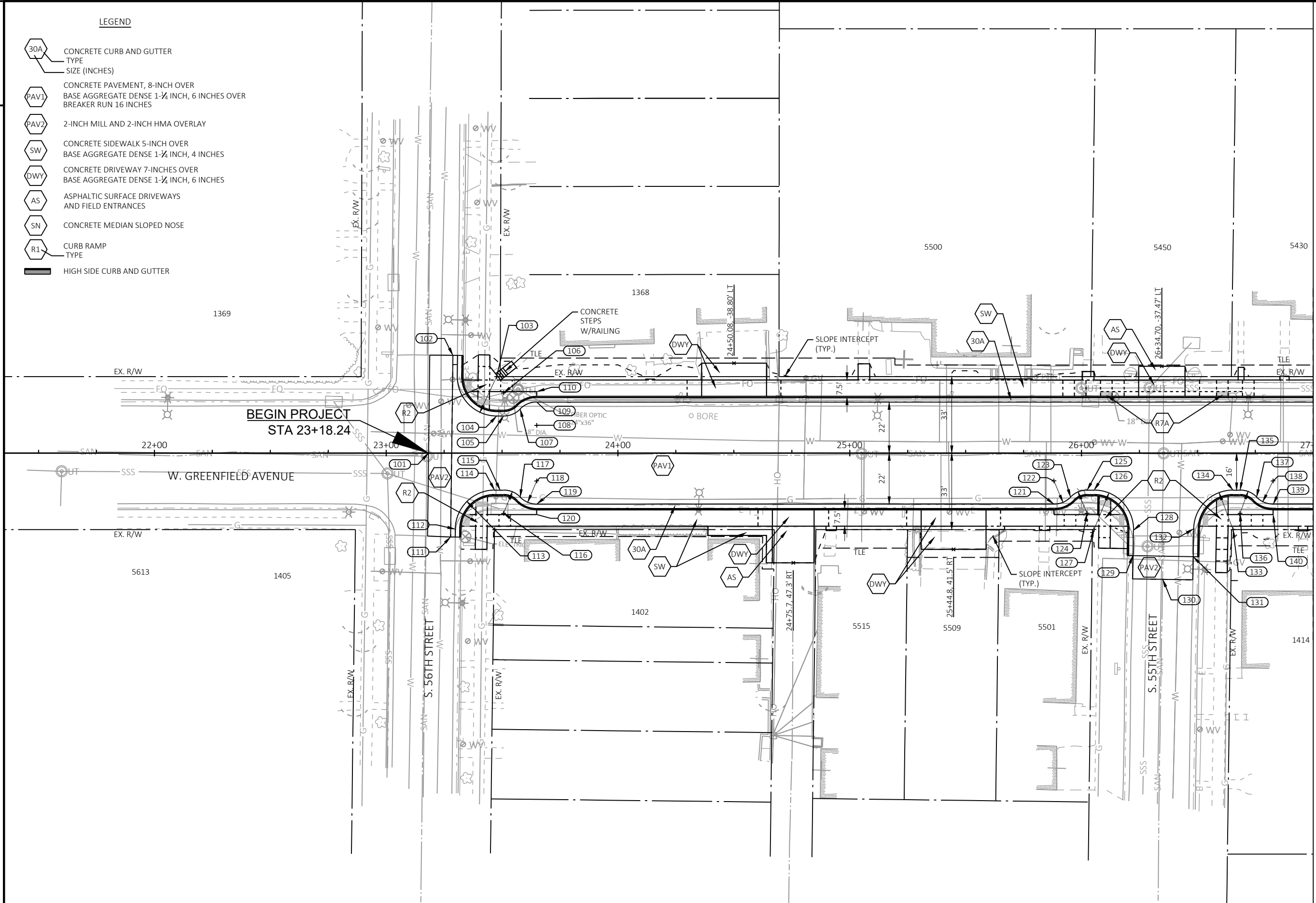

PROJECT NO: 2230-07-73

HWY: W. GREENFIELD AVENUE

COUNTY: MILWAUKEE

PLAN DETAILS









SHEET

E

POINT NUMBER	STATION	OFFSET	DESCRIPTION
101	23+18.24	0.00'	END BUTT JOINT / MATCH EXISTING
102	23+28.76	42.17' LT	SAWCUT / MATCH EXISTING PVMT
103	23+47.65	33.00' LT	C&G - CENTER OF 17' RADIUS
104	23+47.65	16.00' LT	C&G - END 17' RADIUS
105	23+50.65	16.00' LT	C&G - BEGIN 10' RADIUS
106	23+50.65	26.00' LT	C&G - CENTER OF 10' RADIUS
107	23+57.79	19.00' LT	C&G - BEGIN/END 10' RADIUS
108	23+64.93	12.00' LT	C&G - CENTER OF 10' RADIUS
109	23+64.93	22.00' LT	C&G - END 10' RADIUS
110	23+64.93	26.50' LT	SIDEWALK ANGLE POINT
111	23+27.80	36.19' RT	SAWCUT / MATCH EXISTING PVMT
112	23+29.79	32.78' RT	C&G - BEGIN 17' RADIUS
113	23+46.79	33.00' RT	C&G - CENTER OF 17' RADIUS
114	23+46.79	16.00' RT	C&G - END 17' RADIUS
115	23+49.19	16.04' RT	C&G - BEGIN 10' RADIUS
116	23+50.65	26.00' RT	C&G - CENTER OF 10' RADIUS
117	23+57.79	19.00' RT	C&G - END/BEGIN 10' RADIUS
118	23+64.93	12.00' RT	C&G - CENTER OF 10' RADIUS
119	23+64.93	22.00' RT	C&G - END 10' RADIUS
120	23+64.93	26.50' RT	SIDEWALK ANGLE POINT

POINT NUMBER	STATION	OFFSET	DESCRIPTION
121	25+88.14	22.00' RT	C&G - BEGIN 10' RADIUS
122	25+88.14	12.00' RT	C&G - CENTER OF 10' RADIUS
123	25+95.28	19.00' RT	C&G - END/BEGIN 10' RADIUS
124	26+02.42	26.00' RT	C&G - CENTER OF 10' RADIUS
125	26+02.42	16.00' RT	C&G - END 10' RADIUS
126	26+05.42	16.00' RT	C&G - BEGIN 17' RADIUS
127	26+05.42	33.00' RT	C&G - CENTER OF 17' RADIUS
128	26+22.42	33.30' RT	C&G - END 17' RADIUS
129	26+22.23	44.23' RT	END C&G
130	26+35.05	54.46' RT	END BUTT JOINT / MATCH EXISTING
131	26+48.23	44.68' RT	BEGIN C&G
132	26+48.43	32.70' RT	C&G - BEGIN 17' RADIUS
133	26+65.43	33.00' RT	C&G - CENTER OF 17' RADIUS
134	26+65.43	16.00' RT	C&G - END 17' RADIUS
135	26+68.43	16.00' RT	C&G - BEGIN 10' RADIUS
136	26+68.43	26.00' RT	C&G - CENTER OF 10' RADIUS
137	26+75.57	19.00' RT	C&G - END/BEGIN 10' RADIUS
138	26+82.72	12.00' RT	C&G - CENTER OF 10' RADIUS
139	26+82.72	22.00' RT	C&G - END 10' RADIUS
140	26+82.72	26.50' RT	SIDEWALK ANGLE POINT

LEGEND

-  CONCRETE CURB AND GUTTER
TYPE
SIZE (INCHES)
-  CONCRETE PAVEMENT, 8-INCH OVER
BASE AGGREGATE DENSE 1-1/4 INCH, 6 INCHES OVER
BREAKER RUN 16 INCHES
-  2-INCH MILL AND 2-INCH HMA OVERLAY
-  CONCRETE SIDEWALK 5-INCH OVER
BASE AGGREGATE DENSE 1-1/4 INCH, 4 INCHES
-  CONCRETE DRIVEWAY 7-INCHES OVER
BASE AGGREGATE DENSE 1-1/4 INCH, 6 INCHES
-  ASPHALTIC SURFACE DRIVEWAYS
AND FIELD ENTRANCES
-  CONCRETE MEDIAN SLOPED NOSE
-  CURB RAMP
TYPE
-  HIGH SIDE CURB AND GUTTER

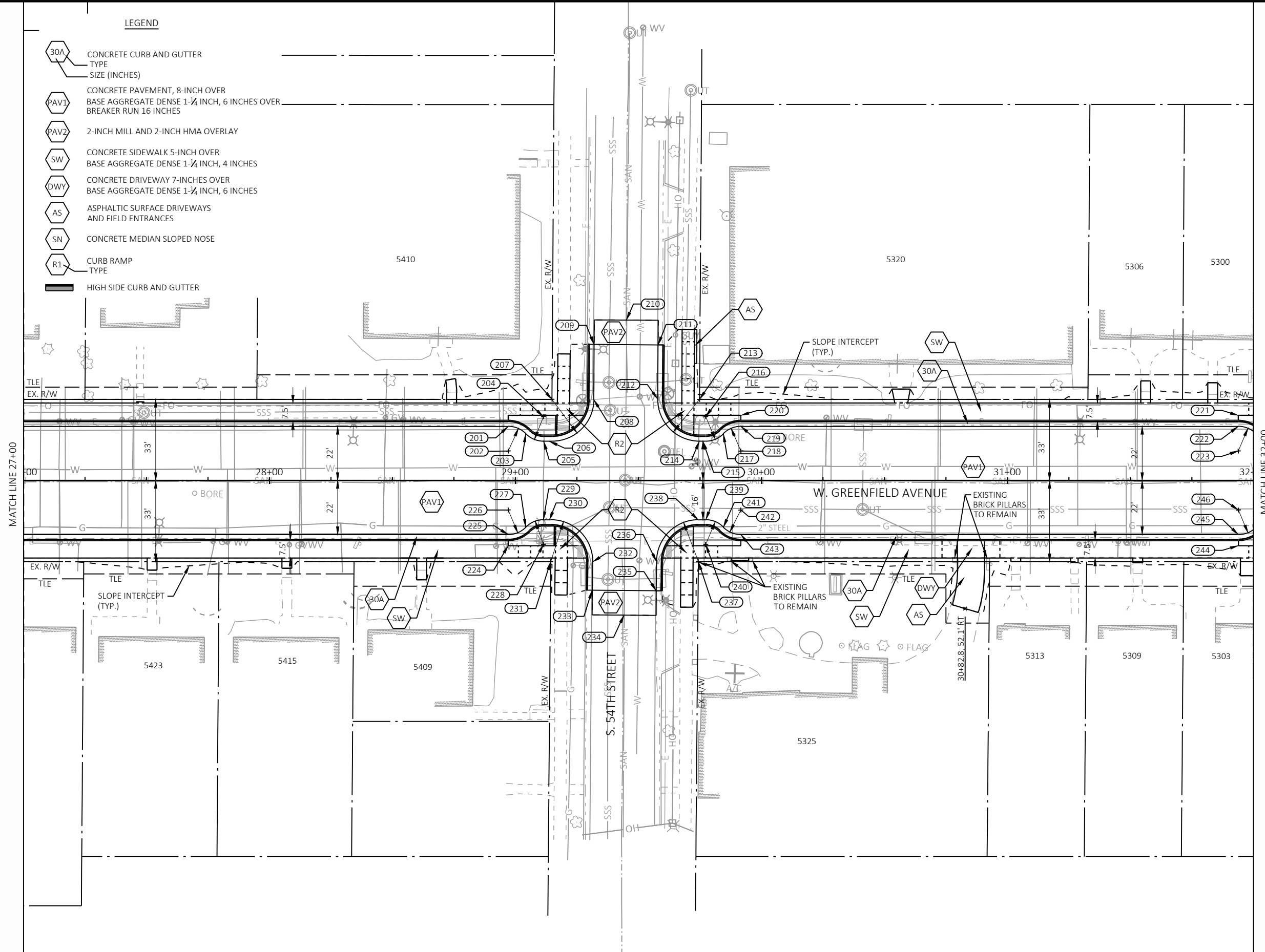









POINT NUMBER	STATION	OFFSET	DESCRIPTION
201	28+97.06	22.00' LT	C&G - BEGIN 10' RADIUS
202	28+97.06	12.00' LT	C&G - CENTER OF 10' RADIUS
203	29+04.20	19.00' LT	C&G - END/BEGIN 10' RADIUS
204	29+11.34	26.00' LT	C&G - CENTER OF 10' RADIUS
205	29+11.34	16.00' LT	C&G - END 10' RADIUS
206	29+13.74	15.96' LT	C&G - BEGIN 17' RADIUS
207	29+14.83	33.00' LT	C&G - CENTER OF 17' RADIUS
208	29+31.83	32.89' LT	C&G - END 17' RADIUS
209	29+31.98	55.35' LT	END C&G
210	29+45.05	65.26' LT	END BUTT JOINT / MATCH EXISTING
211	29+57.98	55.17' LT	BEGIN C&G
212	29+57.83	33.11' LT	C&G - BEGIN 17' RADIUS
213	29+74.83	33.00' LT	C&G - CENTER OF 17' RADIUS
214	29+74.83	16.00' LT	C&G - END 17' RADIUS
215	29+76.20	16.00' LT	C&G - BEGIN 10' RADIUS
216	29+77.34	26.00' LT	C&G - CENTER OF 10' RADIUS
217	29+84.48	19.00' LT	C&G - END/BEGIN 10' RADIUS
218	29+91.62	12.00' LT	C&G - CENTER OF 10' RADIUS
219	29+91.62	22.00' LT	C&G - END 10' RADIUS
220	29+91.62	26.50' LT	SIDEWALK ANGLE POINT
221	31+93.91	26.50' LT	SIDEWALK ANGLE POINT
222	31+93.91	22.00' LT	C&G - BEGIN 10' RADIUS
223	31+93.91	12.00' LT	C&G - CENTER OF 10' RADIUS

POINT NUMBER	STATION	OFFSET	DESCRIPTION
224	28+97.06	26.50' RT	SIDEWALK ANGLE POINT
225	28+97.06	22.00' RT	C&G - BEGIN 10' RADIUS
226	28+97.06	12.00' RT	C&G - CENTER OF 10' RADIUS
227	29+04.20	19.00' RT	C&G - END/BEGIN 10' RADIUS
228	29+11.34	26.00' RT	C&G - CENTER OF 10' RADIUS
229	29+11.34	16.00' RT	C&G - END 10' RADIUS
230	29+13.74	16.04' RT	C&G - BEGIN 17' RADIUS
231	29+14.34	33.00' RT	C&G - CENTER OF 17' RADIUS
232	29+31.34	33.14' RT	C&G - END 17' RADIUS
233	29+31.25	44.64' RT	END C&G
234	29+44.16	54.75' RT	END BUTT JOINT / MATCH EXISTING
235	29+57.24	44.85' RT	BEGIN C&G
236	29+57.34	32.86' RT	C&G - BEGIN 17' RADIUS
237	29+74.34	33.00' RT	C&G - CENTER OF 17' RADIUS
238	29+74.34	16.00' RT	C&G - END 17' RADIUS
239	29+77.34	16.00' RT	C&G - BEGIN 10' RADIUS
240	29+77.34	26.00' RT	C&G - CENTER OF 10' RADIUS
241	29+84.48	19.00' RT	C&G - END/BEGIN 10' RADIUS
242	29+91.62	12.00' RT	C&G - CENTER OF 10' RADIUS
243	29+91.62	22.00' RT	C&G - END 10' RADIUS
244	31+93.96	26.50' RT	SIDEWALK ANGLE POINT
245	31+93.95	22.00' RT	C&G - BEGIN 10' RADIUS
246	31+93.95	12.00' RT	C&G - CENTER OF 10' RADIUS



LEGEND

-  CONCRETE CURB AND GUTTER
TYPE
SIZE (INCHES)
-  CONCRETE PAVEMENT, 8-INCH OVER
BASE AGGREGATE DENSE 1-1/4 INCH, 6 INCHES OVER
BREAKER RUN 16 INCHES
-  2-INCH MILL AND 2-INCH HMA OVERLAY
-  CONCRETE SIDEWALK 5-INCH OVER
BASE AGGREGATE DENSE 1-1/4 INCH, 4 INCHES
-  CONCRETE DRIVEWAY 7-INCHES OVER
BASE AGGREGATE DENSE 1-1/4 INCH, 6 INCHES
-  ASPHALTIC SURFACE DRIVEWAYS
AND FIELD ENTRANCES
-  CONCRETE MEDIAN SLOPED NOSE
-  CURB RAMP
TYPE
-  HIGH SIDE CURB AND GUTTER

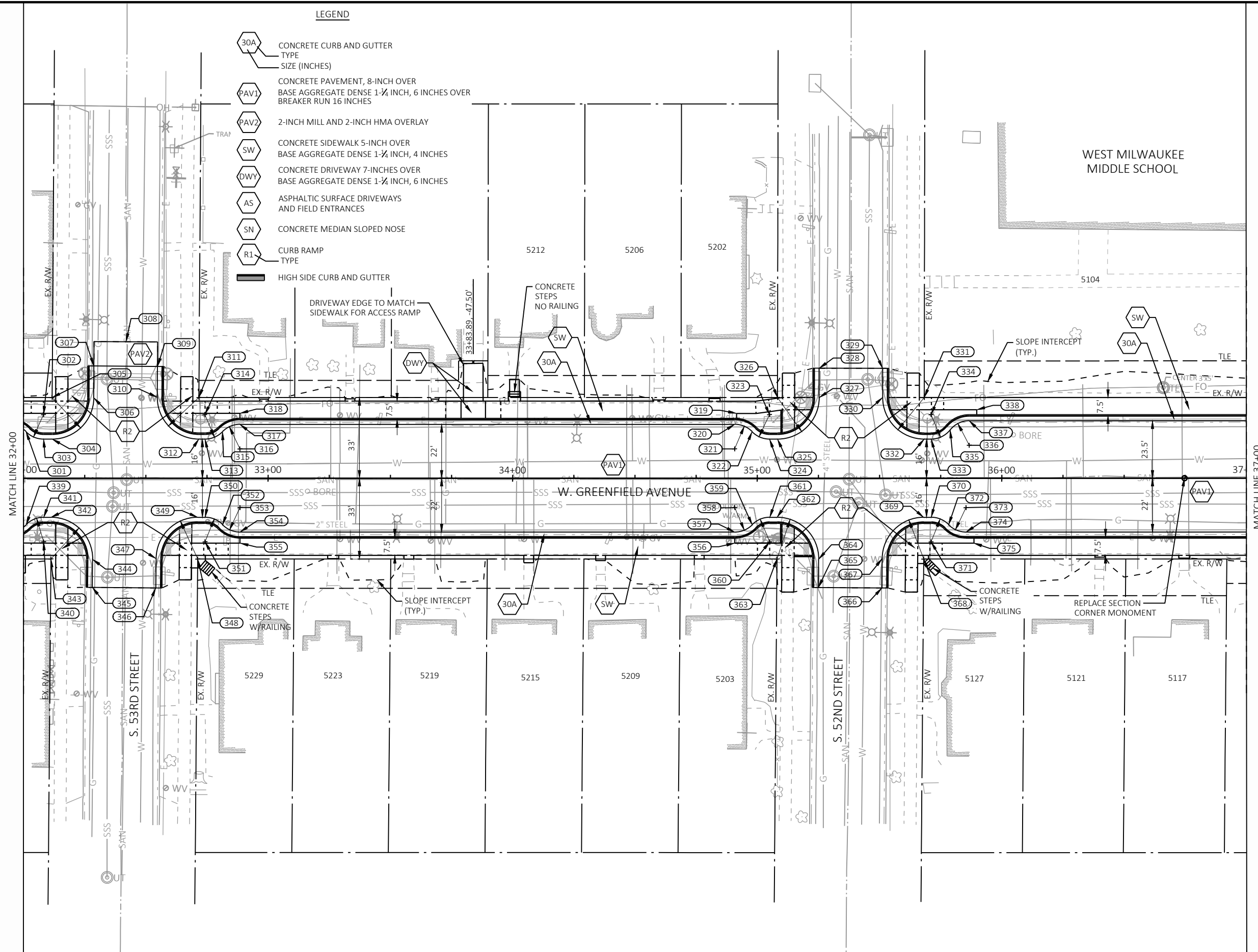

POINT NUMBER	STATION	OFFSET	DESCRIPTION
301	32+01.05	19.00' LT	C&G - END/BEGIN 10' RADIUS
302	32+08.19	26.00' LT	C&G - CENTER OF 10' RADIUS
303	32+08.19	16.00' LT	C&G - END 10' RADIUS
304	32+11.71	16.00' LT	C&G - BEGIN 17' RADIUS
305	32+11.71	33.00' LT	C&G - CENTER OF 17' RADIUS
306	32+28.71	32.89' LT	C&G - END 17' RADIUS
307	32+28.79	45.88' LT	END C&G
308	32+41.86	55.79' LT	END BUTT JOINT / MATCH EXISTING
309	32+54.79	45.71' LT	BEGIN C&G
310	32+54.71	33.11' LT	C&G - BEGIN 17' RADIUS
311	32+71.71	33.00' LT	C&G - CENTER OF 17' RADIUS
312	32+71.71	16.00' LT	C&G - END 17' RADIUS
313	32+74.18	16.00' LT	C&G - BEGIN 10' RADIUS
314	32+74.18	26.00' LT	C&G - CENTER OF 10' RADIUS
315	32+81.33	19.00' LT	C&G - END/BEGIN 10' RADIUS
316	32+88.47	12.00' LT	C&G - CENTER OF 10' RADIUS
317	32+88.47	22.00' LT	C&G - END 10' RADIUS
318	32+88.47	26.50' LT	SIDEWALK ANGLE POINT
319	34+91.55	26.50' LT	SIDEWALK ANGLE POINT
320	34+90.78	22.00' LT	C&G - BEGIN 10' RADIUS
321	34+90.78	12.00' LT	C&G - CENTER OF 10' RADIUS
322	34+97.92	19.00' LT	C&G - END/BEGIN 10' RADIUS
323	35+05.06	26.00' LT	C&G - CENTER OF 10' RADIUS
324	35+05.06	16.00' LT	C&G - END 10' RADIUS
325	35+08.30	16.00' LT	C&G - BEGIN 17' RADIUS

POINT NUMBER	STATION	OFFSET	DESCRIPTION
326	35+08.30	33.00' LT	C&G - CENTER OF 17' RADIUS
327	35+25.30	32.97' LT	C&G - END 17' RADIUS
328	35+25.32	44.97' LT	END C&G
329	35+51.32	44.92' LT	BEGIN C&G
330	35+51.30	33.03' LT	C&G - BEGIN 17' RADIUS
331	35+68.30	33.00' LT	C&G - CENTER OF 17' RADIUS
332	35+68.30	16.00' LT	C&G - END 17' RADIUS
333	35+71.07	16.00' LT	C&G - BEGIN 10' RADIUS
334	35+71.07	26.00' LT	C&G - CENTER OF 10' RADIUS
335	35+78.87	19.75' LT	C&G - END/BEGIN 10' RADIUS
336	35+86.68	13.50' LT	C&G - CENTER OF 10' RADIUS
337	35+86.68	23.50' LT	C&G - END 10' RADIUS
338	35+89.77	28.00' LT	SIDEWALK ANGLE POINT
339	32+01.09	19.00' RT	C&G - END/BEGIN 10' RADIUS
340	32+08.23	26.00' RT	C&G - CENTER OF 10' RADIUS
341	32+08.22	16.00' RT	C&G - END 10' RADIUS
342	32+11.22	16.00' RT	C&G - BEGIN 17' RADIUS
343	32+11.22	33.00' RT	C&G - CENTER OF 17' RADIUS
344	32+28.22	33.14' RT	C&G - END 17' RADIUS
345	32+28.13	44.64' RT	END C&G
346	32+54.12	44.85' RT	BEGIN C&G
347	32+54.22	32.86' RT	C&G - BEGIN 17' RADIUS
348	32+71.22	33.00' RT	C&G - CENTER OF 17' RADIUS
349	32+71.21	16.00' RT	C&G - END 17' RADIUS
350	32+74.22	16.00' RT	C&G - BEGIN 10' RADIUS

POINT NUMBER	STATION	OFFSET	DESCRIPTION
351	32+74.23	26.00' RT	C&G - CENTER OF 10' RADIUS
352	32+81.37	19.00' RT	C&G - END/BEGIN 10' RADIUS
353	32+88.52	12.00' RT	C&G - CENTER OF 10' RADIUS
354	32+88.52	22.00' RT	C&G - END 10' RADIUS
355	32+88.52	26.50' RT	SIDEWALK ANGLE POINT
356	34+90.83	26.50' RT	SIDEWALK ANGLE POINT
357	34+90.83	22.00' RT	C&G - BEGIN 10' RADIUS
358	34+90.83	12.00' RT	C&G - CENTER OF 10' RADIUS
359	34+97.97	19.00' RT	C&G - END/BEGIN 10' RADIUS
360	35+05.11	26.00' RT	C&G - CENTER OF 10' RADIUS
361	35+05.11	16.00' RT	C&G - END 10' RADIUS
362	35+08.10	16.00' RT	C&G - BEGIN 17' RADIUS
363	35+08.10	33.00' RT	C&G - CENTER OF 17' RADIUS
364	35+25.10	33.14' RT	C&G - END 17' RADIUS
365	35+25.00	44.64' RT	END C&G
366	35+51.00	44.85' RT	BEGIN C&G
367	35+51.10	32.86' RT	C&G - BEGIN 17' RADIUS
368	35+68.10	33.00' RT	C&G - CENTER OF 17' RADIUS
369	35+68.10	16.00' RT	C&G - END 17' RADIUS
370	35+71.11	16.00' RT	C&G - BEGIN 10' RADIUS
371	35+71.11	26.00' RT	C&G - CENTER OF 10' RADIUS
372	35+78.25	19.00' RT	C&G - END/BEGIN 10' RADIUS
373	35+85.39	12.00' RT	C&G - CENTER OF 10' RADIUS
374	35+85.39	22.00' RT	C&G - END 10' RADIUS
375	35+88.66	26.50' RT	SIDEWALK ANGLE POINT

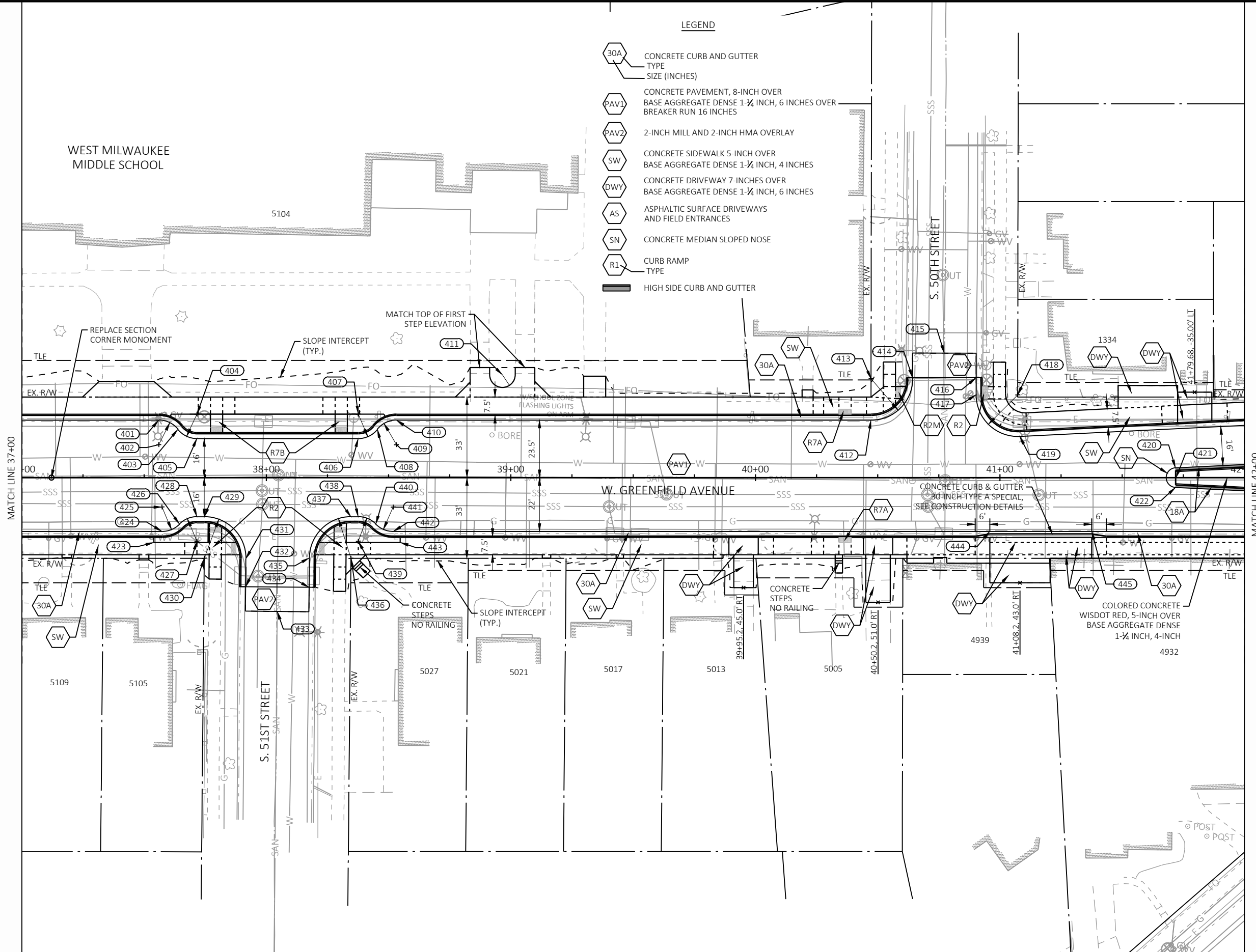

LEGEND

- CONCRETE CURB AND GUTTER
TYPE
SIZE (INCHES)
- CONCRETE PAVEMENT, 8-INCH OVER
BASE AGGREGATE DENSE 1-1/2 INCH, 6 INCHES OVER
BREAKER RUN 16 INCHES
- 2-INCH MILL AND 2-INCH HMA OVERLAY
- CONCRETE SIDEWALK 5-INCH OVER
BASE AGGREGATE DENSE 1-1/2 INCH, 4 INCHES
- CONCRETE DRIVEWAY 7-INCHES OVER
BASE AGGREGATE DENSE 1-1/2 INCH, 6 INCHES
- ASPHALTIC SURFACE DRIVEWAYS
AND FIELD ENTRANCES
- CONCRETE MEDIAN SLOPED NOSE
- CURB RAMP
TYPE
- HIGH SIDE CURB AND GUTTER

WEST MILWAUKEE
MIDDLE SCHOOL

5104

REPLACE SECTION
CORNER MONUMENT

MATCH TOP OF FIRST
STEP ELEVATION

SLOPE INTERCEPT
(TYP.)

W. GREENFIELD AVENUE

S. 50TH STREET

S. 51ST STREET









MATCH LINE 37+00

MATCH LINE 42+00

POINT NUMBER	STATION	OFFSET	DESCRIPTION
401	37+55.97	23.50' LT	C&G - BEGIN 10' RADIUS
402	37+55.97	13.50' LT	C&G - CENTER OF 10' RADIUS
403	37+63.77	19.75' LT	C&G - END/BEGIN 10' RADIUS
404	37+71.58	26.00' LT	C&G - CENTER OF 10' RADIUS
405	37+71.59	16.00' LT	C&G - END 10' RADIUS
406	38+37.58	16.00' LT	C&G - BEGIN 10' RADIUS
407	38+37.58	26.00' LT	C&G - CENTER OF 10' RADIUS
408	38+45.39	19.75' LT	C&G - END/BEGIN 10' RADIUS
409	38+53.19	13.50' LT	C&G - CENTER OF 10' RADIUS
410	38+53.19	23.50' LT	C&G - END 10' RADIUS
411	38+96.53	42.11' LT	SIDEWALK - CENTER OF 10.5' RADIUS
412	40+47.29	23.50' LT	C&G - BEGIN 17' RADIUS
413	40+47.29	40.50' LT	C&G - CENTER OF 17' RADIUS
414	40+64.29	40.97' LT	C&G - END 17' RADIUS, END C&G
415	40+77.31	50.95' LT	END BUTT JOINT / MATCH EXISTING
416	40+90.29	40.92' LT	BEGIN C&G
417	40+90.28	33.90' LT	C&G - BEGIN 17' RADIUS
418	41+07.28	33.87' LT	C&G - CENTER OF 17' RADIUS
419	41+08.11	16.89' LT	C&G - END 17' RADIUS
420	41+71.85	4.00' LT	BEGIN HIGHSIDE C&G
421	41+72.05	0.00'	CENTER OF 4' R SLOPE NOSE
422	41+71.85	4.00' RT	BEGIN HIGHSIDE C&G
423	37+53.96	26.50' RT	SIDEWALK ANGLE POINT

POINT NUMBER	STATION	OFFSET	DESCRIPTION
424	37+57.30	22.00' RT	C&G - BEGIN 10' RADIUS
425	37+57.30	12.00' RT	C&G - CENTER OF 10' RADIUS
426	37+64.44	19.00' RT	C&G - END/BEGIN 10' RADIUS
427	37+71.58	26.00' RT	C&G - CENTER OF 10' RADIUS
428	37+71.58	16.00' RT	C&G - END 10' RADIUS
429	37+74.54	16.00' RT	C&G - BEGIN 17' RADIUS
430	37+74.58	33.00' RT	C&G - CENTER OF 17' RADIUS
431	37+91.58	33.15' RT	C&G - END 17' RADIUS
432	37+91.48	44.60' RT	END C&G
433	38+04.39	54.72' RT	END BUTT JOINT / MATCH EXISTING
434	38+17.48	44.84' RT	BEGIN C&G
435	38+17.58	32.85' RT	C&G - BEGIN 17' RADIUS
436	38+34.58	33.00' RT	C&G - CENTER OF 17' RADIUS
437	38+34.58	16.00' RT	C&G - END 17' RADIUS
438	38+37.58	16.00' RT	C&G - BEGIN 10' RADIUS
439	38+37.58	26.00' RT	C&G - CENTER OF 10' RADIUS
440	38+44.72	19.00' RT	C&G - END/BEGIN 10' RADIUS
441	38+51.87	12.00' RT	C&G - CENTER OF 10' RADIUS
442	38+51.87	22.00' RT	C&G - END 10' RADIUS
443	38+54.72	26.50' RT	SIDEWALK ANGLE POINT
444	40+95.89	22.00' RT	END C&G 30A, BEGIN C&G SPECIAL
445	41+37.56	22.00' RT	END C&G SPECIAL, BEGIN C&G 30A

LEGEND

-  CONCRETE CURB AND GUTTER TYPE SIZE (INCHES)
-  CONCRETE PAVEMENT, 8-INCH OVER BASE AGGREGATE DENSE 1-1/4 INCH, 6 INCHES OVER BREAKER RUN 16 INCHES
-  2-INCH MILL AND 2-INCH HMA OVERLAY
-  CONCRETE SIDEWALK 5-INCH OVER BASE AGGREGATE DENSE 1-1/4 INCH, 4 INCHES
-  CONCRETE DRIVEWAY 7-INCHES OVER BASE AGGREGATE DENSE 1-1/4 INCH, 6 INCHES
-  ASPHALTIC SURFACE DRIVEWAYS AND FIELD ENTRANCES
-  CONCRETE MEDIAN SLOPED NOSE
-  CURB RAMP TYPE
-  HIGH SIDE CURB AND GUTTER

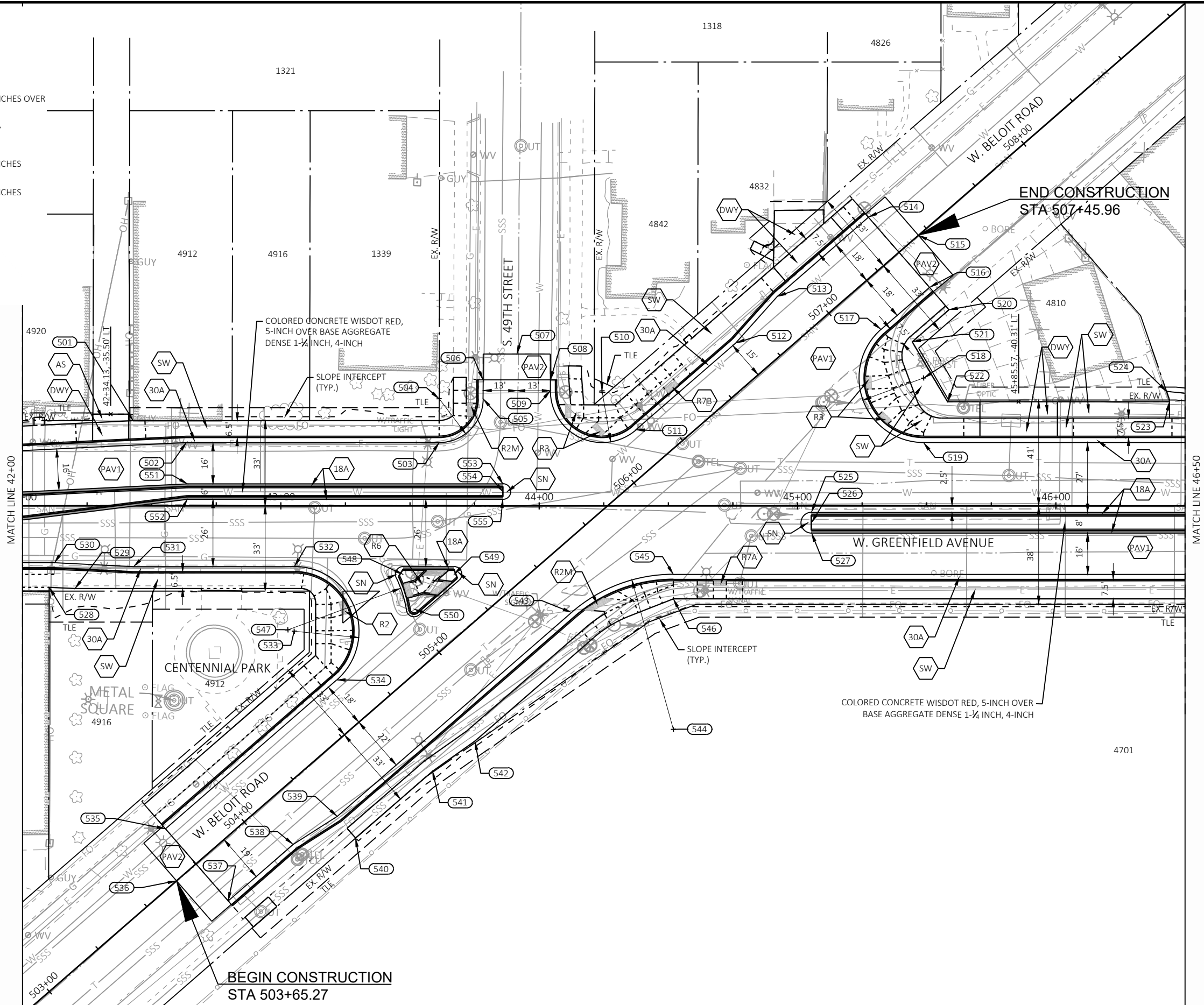









POINT NUMBER	STATION	OFFSET	DESCRIPTION
501	42+42.78	33.00' LT	SIDEWALK ANGLE POINT
502	42+63.43	24.50' LT	C&G ANGLE POINT
503	43+61.30	24.50' LT	C&G - BEGIN OF 17' RADIUS
504	43+61.30	41.50' LT	C&G - CENTER OF 17' RADIUS
505	43+78.30	41.47' LT	C&G - END OF 17' RADIUS
506	43+78.31	48.82' LT	END C&G
507	43+91.33	58.80' LT	END BUTT JOINT / MATCH EXISTING
508	44+04.31	48.78' LT	BEGIN C&G
509	44+04.30	44.59' LT	C&G - BEGIN 20' RADIUS
510	44+24.30	44.55' LT	C&G - CENTER OF 20' RADIUS
511	44+37.43	29.47' LT	C&G - END 20' RADIUS
512	44+76.06	63.09' LT	C&G ANGLE POINT
513	44+92.19	81.11' LT	C&G ANGLE POINT
514	45+27.43	111.77' LT	END C&G
515	45+46.79	104.76' LT	END BUTT JOINT / MATCH EXISTING
516	45+51.07	84.62' LT	BEGIN C&G
517	45+32.38	68.36' LT	C&G - BEGIN 25' RADIUS
518	45+48.80	49.50' LT	C&G - CENTER OF 25' RADIUS
519	45+48.80	24.50' LT	C&G - END 25' RADIUS
520	45+58.62	75.94' LT	SIDEWALK MATCH POINT

POINT NUMBER	STATION	OFFSET	DESCRIPTION
521	45+44.37	63.55' LT	SIDEWALK MATCH POINT
522	45+58.09	40.31' LT	SIDEWALK MATCH POINT
523	46+44.01	40.31' LT	SIDEWALK MATCH POINT
524	46+42.85	44.35' LT	ASPHALT PAVEMENT LIMIT
525	45+05.36	2.50' RT	BEGIN HIGHSIDE C&G
526	45+05.36	6.50' RT	CENTER OF 4' R SLOPE NOSE
527	45+05.36	10.50' RT	BEGIN HIGHSIDE C&G
528	42+10.31	31.50' RT	SIDEWALK ANGLE POINT
529	42+20.31	32.00' RT	SIDEWALK ANGLE POINT
530	42+12.39	22.00' RT	C&G ANGLE POINT
531	42+43.01	23.50' RT	C&G ANGLE POINT
532	43+05.19	23.50' RT	C&G - BEGIN 25' RADIUS
533	43+05.19	48.50' RT	C&G - CENTER OF 25' RADIUS
534	43+21.61	67.36' RT	C&G - END 25' RADIUS
535	42+55.36	125.02' RT	END C&G
536	42+59.63	145.16' RT	END BUTT JOINT / MATCH EXISTING
537	42+79.65	152.93' RT	BEGIN C&G
538	43+04.78	131.06' RT	C&G ANGLE POINT
539	43+21.83	120.19' RT	C&G ANGLE POINT
540	43+28.91	128.61' RT	BEGIN SIDEWALK

POINT NUMBER	STATION	OFFSET	DESCRIPTION
541	43+58.70	102.68' RT	SIDEWALK ANGLE POINT
542	43+75.10	91.06' RT	SIDEWALK ANGLE POINT
543	44+12.55	41.24' RT	C&G - BEGIN 60' RADIUS
544	44+51.94	86.50' RT	C&G - CENTER OF 60' RADIUS
545	44+51.94	26.50' RT	C&G - END 60' RADIUS
546	44+51.94	36.00' RT	SIDEWALK ANGLE POINT
547	43+02.72	48.00' RT	C&G - CENTER OF 46.5' RADIUS
548	43+47.31	26.50' RT	CENTER OF 3' R SLOPE NOSE
549	43+67.03	26.50' RT	CENTER OF 3' R SLOPE NOSE
550	43+51.56	39.96' RT	CENTER OF 3' R SLOPE NOSE
551	42+63.82	8.50' LT	C&G ANGLE POINT
552	42+63.82	2.50' LT	C&G ANGLE POINT
553	43+85.94	8.50' LT	END HIGHSIDE C&G
554	43+85.94	5.50' LT	CENTER OF 3' R SLOPE NOSE
555	43+85.94	2.50' LT	END HIGHSIDE C&G

LEGEND

-  CONCRETE CURB AND GUTTER TYPE SIZE (INCHES)
-  CONCRETE PAVEMENT, 8-INCH OVER BASE AGGREGATE DENSE 1-1/4 INCH, 6 INCHES OVER BREAKER RUN 16 INCHES
-  2-INCH MILL AND 2-INCH HMA OVERLAY
-  CONCRETE SIDEWALK 5-INCH OVER BASE AGGREGATE DENSE 1-1/4 INCH, 4 INCHES
-  CONCRETE DRIVEWAY 7-INCHES OVER BASE AGGREGATE DENSE 1-1/4 INCH, 6 INCHES
-  ASPHALTIC SURFACE DRIVEWAYS AND FIELD ENTRANCES
-  CONCRETE MEDIAN SLOPED NOSE
-  CURB RAMP TYPE
-  HIGH SIDE CURB AND GUTTER



MATCH LINE 46+50

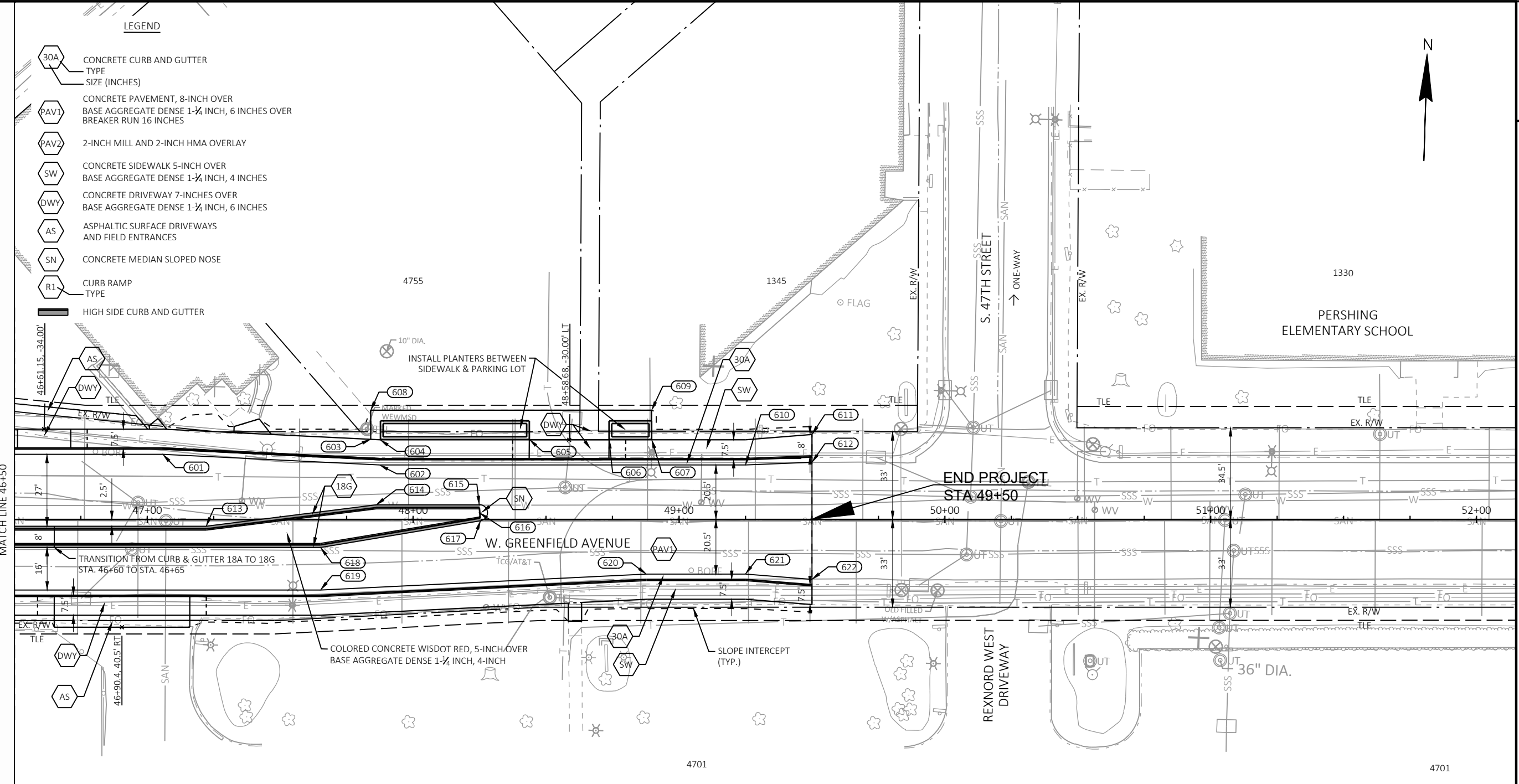

POINT NUMBER	STATION	OFFSET	DESCRIPTION
601	47+05.80	24.50' LT	C&G ANGLE POINT
602	47+87.36	20.50' LT	C&G ANGLE POINT
603	47+84.02	30.18' LT	SIDEWALK ANGLE POINT
604	47+87.60	30.00' LT	BEGIN RAISED PLANTER
605	48+43.69	30.12' LT	END RAISED PLANTER
606	48+73.69	30.12' LT	BEGIN RAISED PLANTER
607	48+89.69	30.12' LT	END RAISED PLANTER
608	47+84.02	41.12' LT	SAWCUT & MATCH EXISTING PARKING LOT
609	48+89.69	41.12' LT	SAWCUT & MATCH EXISTING PARKING LOT
610	49+25.00	20.47' LT	C&G ANGLE POINT
611	49+50.00	32.00' LT	END SIDEWALK
612	49+50.00	21.50' LT	END C&G
613	47+22.05	2.50' RT	C&G ANGLE POINT
614	47+86.05	5.50' LT	C&G ANGLE POINT
615	48+24.90	5.50' LT	END HIGHSIDE C&G
616	48+24.90	2.50' LT	CENTER OF 3' R SLOPE NOSE
617	48+25.40	0.46' RT	END HIGHSIDE C&G
618	47+65.15	10.50' RT	C&G ANGLE POINT
619	47+65.15	26.50' RT	C&G ANGLE POINT
620	48+87.72	20.50' RT	C&G ANGLE POINT
621	49+25.00	20.50' RT	C&G ANGLE POINT
622	49+50.00	22.50' RT	END C&G

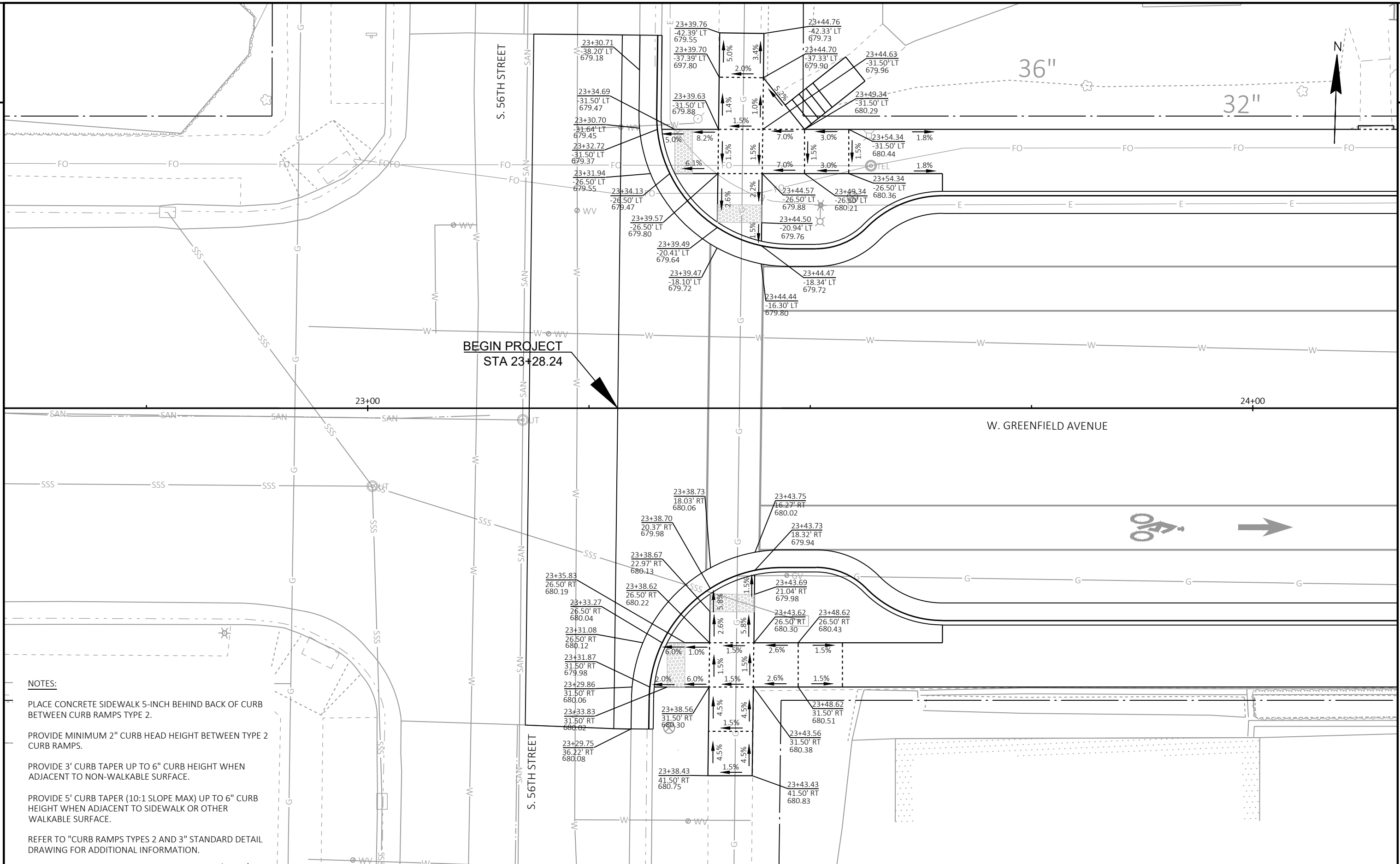

BEGIN PROJECT
STA 23+28.24

- NOTES:**
- PLACE CONCRETE SIDEWALK 5-INCH BEHIND BACK OF CURB BETWEEN CURB RAMPS TYPE 2.
 - PROVIDE MINIMUM 2" CURB HEAD HEIGHT BETWEEN TYPE 2 CURB RAMPS.
 - PROVIDE 3' CURB TAPER UP TO 6" CURB HEIGHT WHEN ADJACENT TO NON-WALKABLE SURFACE.
 - PROVIDE 5' CURB TAPER (10:1 SLOPE MAX) UP TO 6" CURB HEIGHT WHEN ADJACENT TO SIDEWALK OR OTHER WALKABLE SURFACE.
 - REFER TO "CURB RAMPS TYPES 2 AND 3" STANDARD DETAIL DRAWING FOR ADDITIONAL INFORMATION.

PROJECT NO: 2230-07-73	HWY: W. GREENFIELD AVENUE	COUNTY: MILWAUKEE	CURB RAMP DETAILS	SHEET	E
------------------------	---------------------------	-------------------	-------------------	-------	---

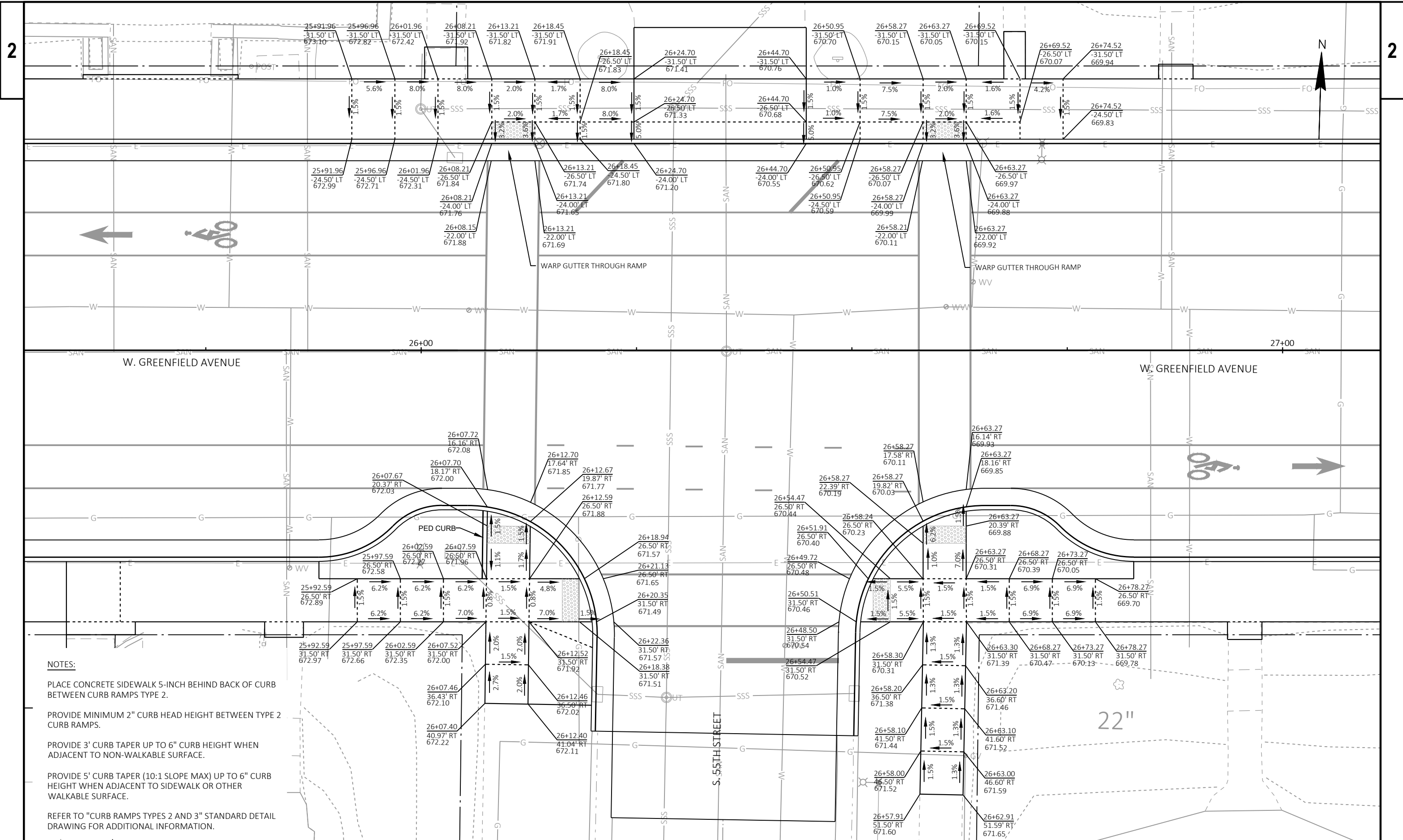

NOTES:

- PLACE CONCRETE SIDEWALK 5-INCH BEHIND BACK OF CURB BETWEEN CURB RAMPS TYPE 2.
- PROVIDE MINIMUM 2" CURB HEAD HEIGHT BETWEEN TYPE 2 CURB RAMPS.
- PROVIDE 3' CURB TAPER UP TO 6" CURB HEIGHT WHEN ADJACENT TO NON-WALKABLE SURFACE.
- PROVIDE 5' CURB TAPER (10:1 SLOPE MAX) UP TO 6" CURB HEIGHT WHEN ADJACENT TO SIDEWALK OR OTHER WALKABLE SURFACE.
- REFER TO "CURB RAMPS TYPES 2 AND 3" STANDARD DETAIL DRAWING FOR ADDITIONAL INFORMATION.

PROJECT NO: 2230-07-73	HWY: W. GREENFIELD AVENUE	COUNTY: MILWAUKEE	CURB RAMP DETAILS	SHEET	E
------------------------	---------------------------	-------------------	-------------------	-------	----------

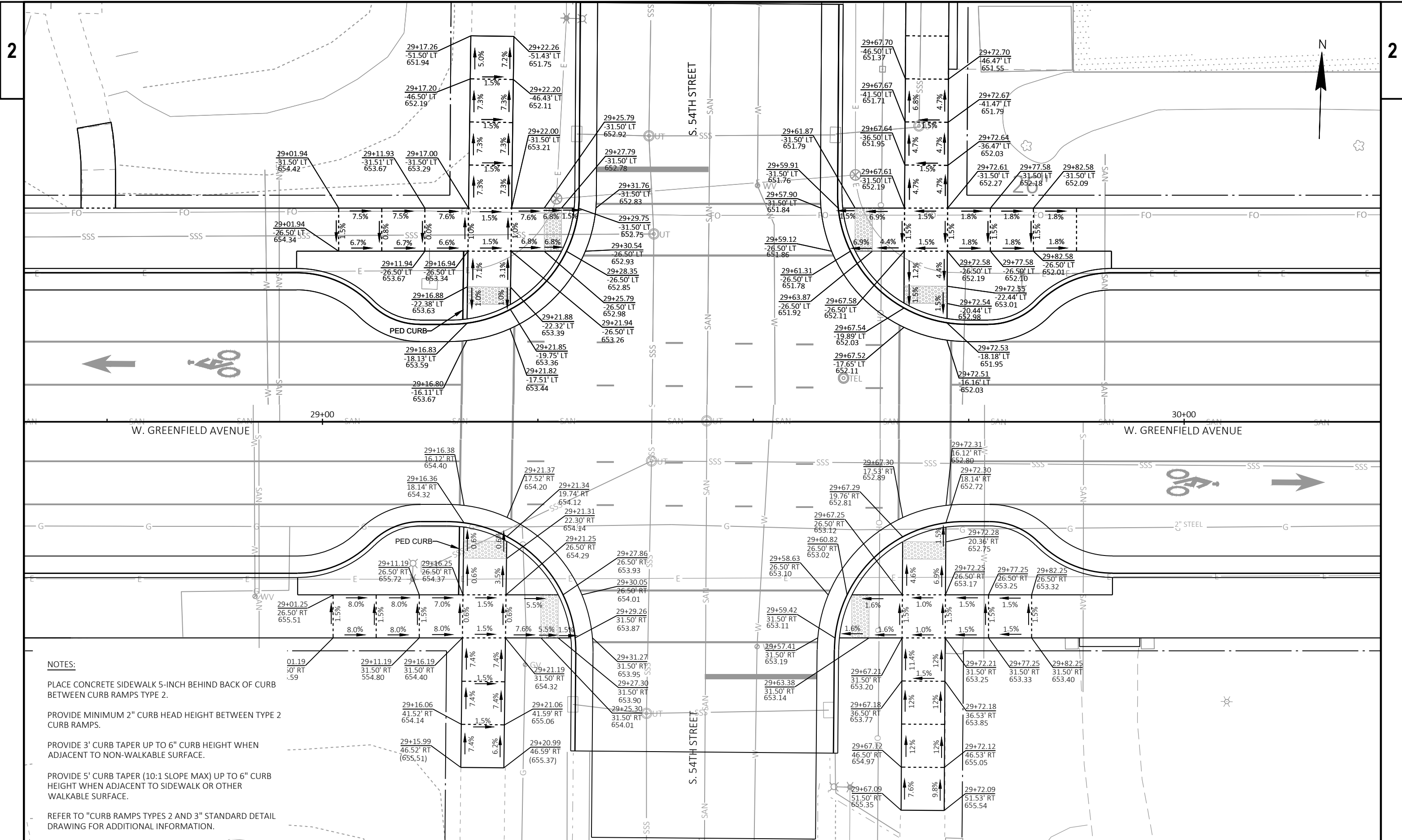

NOTES:

- PLACE CONCRETE SIDEWALK 5-INCH BEHIND BACK OF CURB BETWEEN CURB RAMPS TYPE 2.
- PROVIDE MINIMUM 2" CURB HEAD HEIGHT BETWEEN TYPE 2 CURB RAMPS.
- PROVIDE 3' CURB TAPER UP TO 6" CURB HEIGHT WHEN ADJACENT TO NON-WALKABLE SURFACE.
- PROVIDE 5' CURB TAPER (10:1 SLOPE MAX) UP TO 6" CURB HEIGHT WHEN ADJACENT TO SIDEWALK OR OTHER WALKABLE SURFACE.
- REFER TO "CURB RAMPS TYPES 2 AND 3" STANDARD DETAIL DRAWING FOR ADDITIONAL INFORMATION.

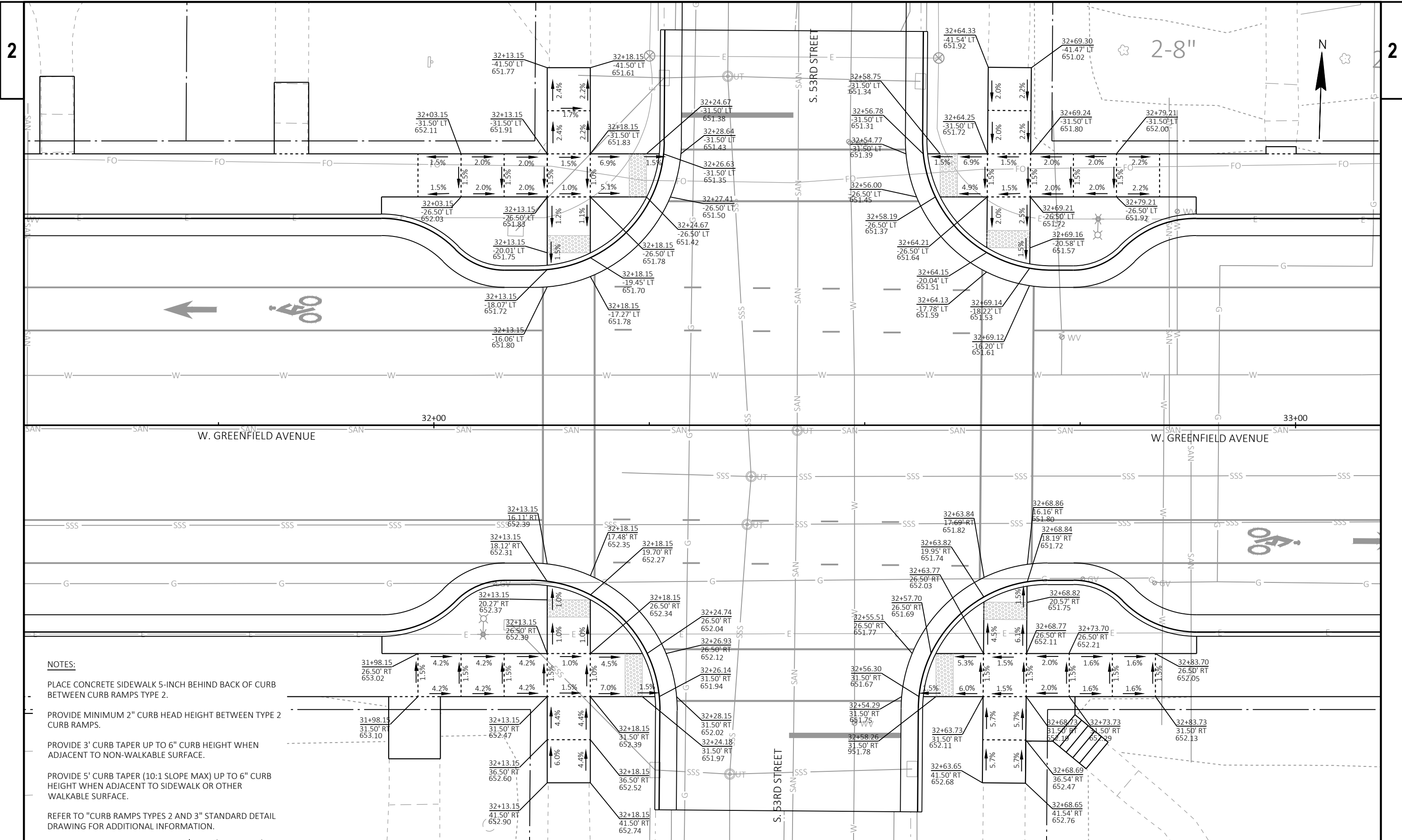

NOTES:

- PLACE CONCRETE SIDEWALK 5-INCH BEHIND BACK OF CURB BETWEEN CURB RAMPS TYPE 2.
- PROVIDE MINIMUM 2" CURB HEAD HEIGHT BETWEEN TYPE 2 CURB RAMPS.
- PROVIDE 3' CURB TAPER UP TO 6" CURB HEIGHT WHEN ADJACENT TO NON-WALKABLE SURFACE.
- PROVIDE 5' CURB TAPER (10:1 SLOPE MAX) UP TO 6" CURB HEIGHT WHEN ADJACENT TO SIDEWALK OR OTHER WALKABLE SURFACE.
- REFER TO "CURB RAMPS TYPES 2 AND 3" STANDARD DETAIL DRAWING FOR ADDITIONAL INFORMATION.

PROJECT NO: 2230-07-73	HWY: W. GREENFIELD AVENUE	COUNTY: MILWAUKEE	CURB RAMP DETAILS	SHEET	E
------------------------	---------------------------	-------------------	-------------------	-------	---

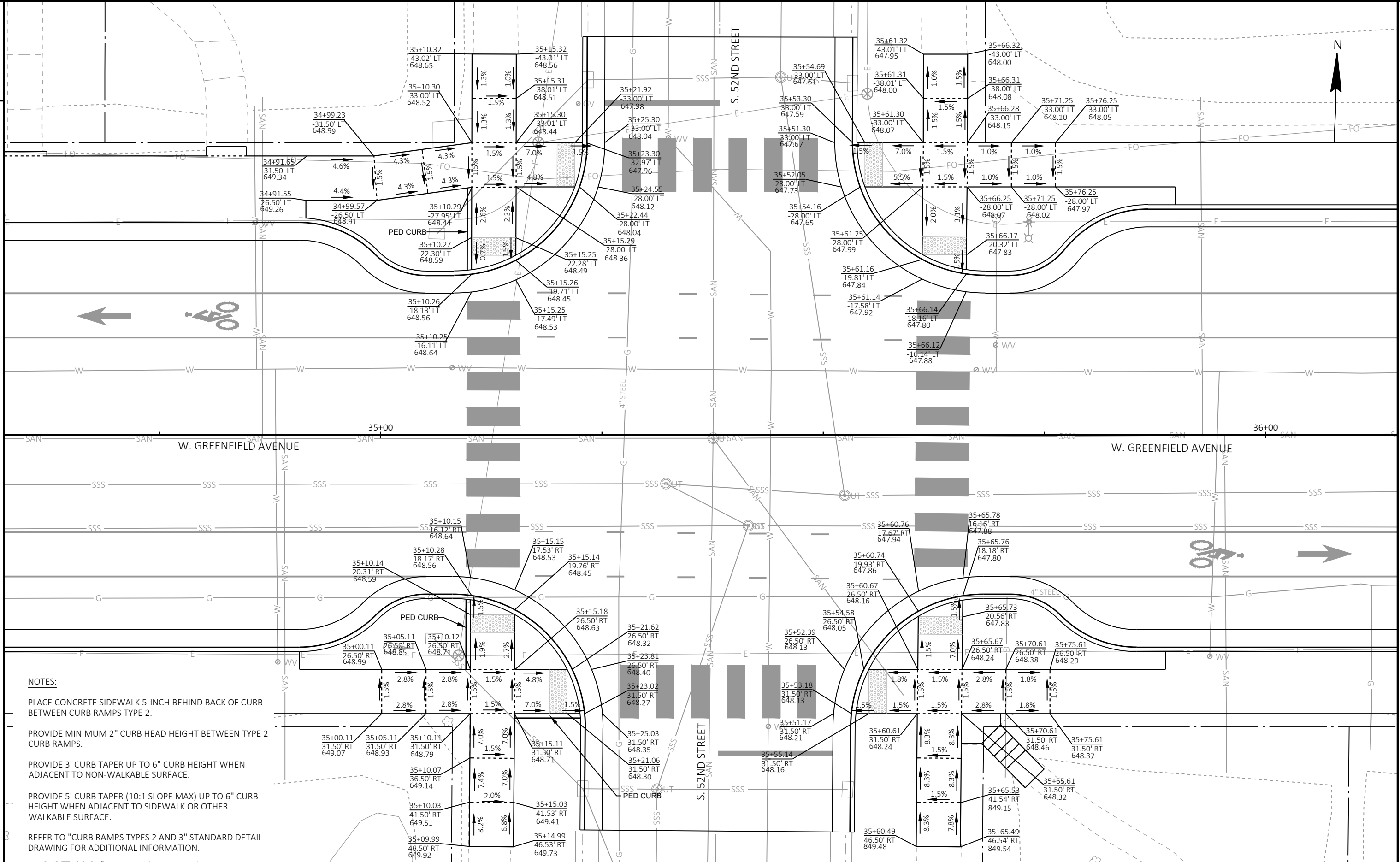

- NOTES:**
- PLACE CONCRETE SIDEWALK 5-INCH BEHIND BACK OF CURB BETWEEN CURB RAMPS TYPE 2.
 - PROVIDE MINIMUM 2" CURB HEAD HEIGHT BETWEEN TYPE 2 CURB RAMPS.
 - PROVIDE 3' CURB TAPER UP TO 6" CURB HEIGHT WHEN ADJACENT TO NON-WALKABLE SURFACE.
 - PROVIDE 5' CURB TAPER (10:1 SLOPE MAX) UP TO 6" CURB HEIGHT WHEN ADJACENT TO SIDEWALK OR OTHER WALKABLE SURFACE.
 - REFER TO "CURB RAMPS TYPES 2 AND 3" STANDARD DETAIL DRAWING FOR ADDITIONAL INFORMATION.

PROJECT NO: 2230-07-73	HWY: W. GREENFIELD AVENUE	COUNTY: MILWAUKEE	CURB RAMP DETAILS	SHEET	E
------------------------	---------------------------	-------------------	-------------------	-------	----------

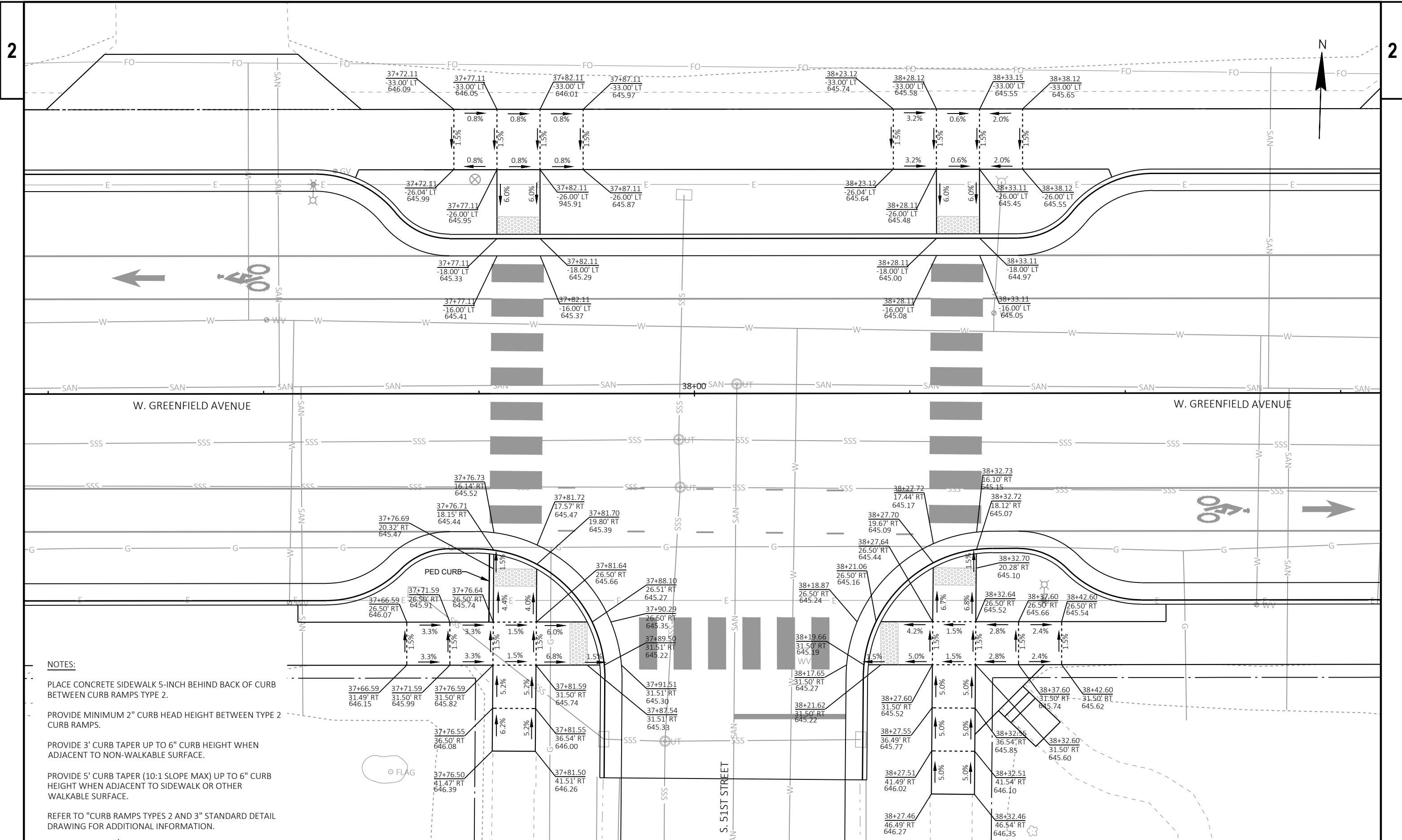

NOTES:

- PLACE CONCRETE SIDEWALK 5-INCH BEHIND BACK OF CURB BETWEEN CURB RAMPS TYPE 2.
- PROVIDE MINIMUM 2" CURB HEAD HEIGHT BETWEEN TYPE 2 CURB RAMPS.
- PROVIDE 3' CURB TAPER UP TO 6" CURB HEIGHT WHEN ADJACENT TO NON-WALKABLE SURFACE.
- PROVIDE 5' CURB TAPER (10:1 SLOPE MAX) UP TO 6" CURB HEIGHT WHEN ADJACENT TO SIDEWALK OR OTHER WALKABLE SURFACE.
- REFER TO "CURB RAMPS TYPES 2 AND 3" STANDARD DETAIL DRAWING FOR ADDITIONAL INFORMATION.

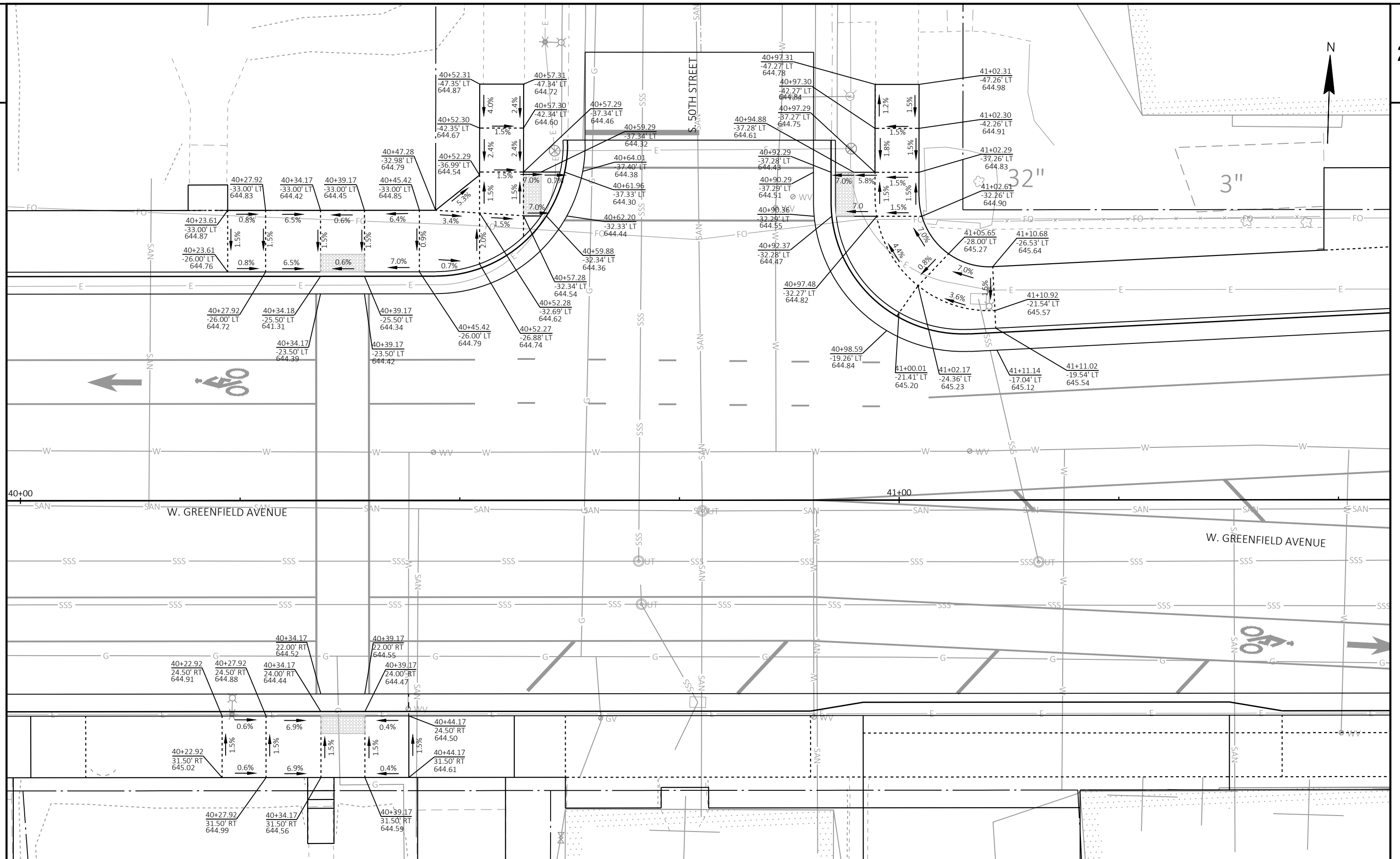

PROJECT NO: 2230-07-73

HWY: W. GREENFIELD AVENUE

COUNTY: MILWAUKEE

CURB RAMP DETAILS

SHEET

E

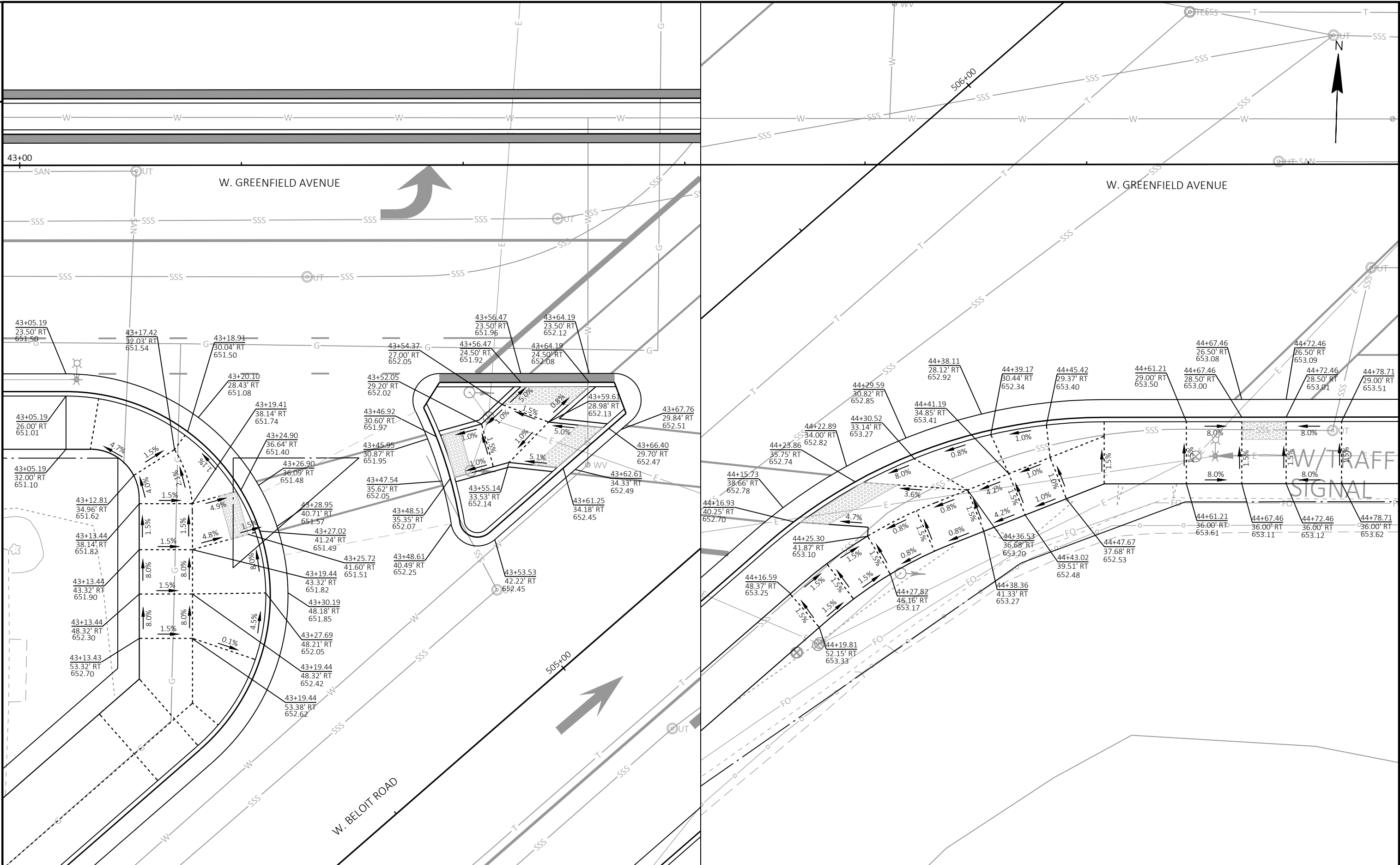

PROJECT NO: 2230-07-73	HWY: W. GREENFIELD AVENUE	COUNTY: MILWAUKEE	CURB RAMP DETAILS	SHEET	E
------------------------	---------------------------	-------------------	-------------------	-------	---

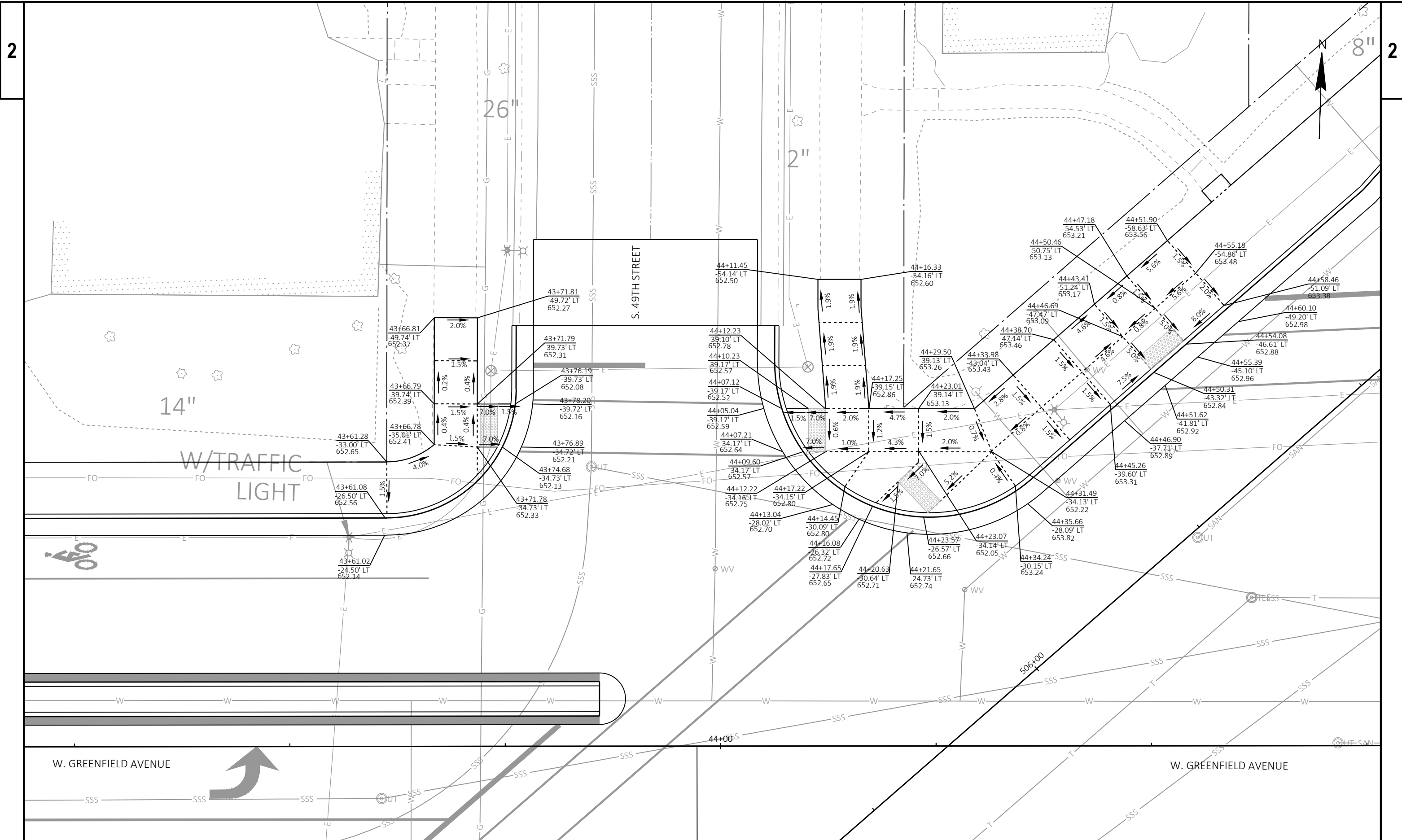

PROJECT NO: 2230-07-73

HWY: W. GREENFIELD AVENUE

COUNTY: MILWAUKEE

CURB RAMP DETAILS

SHEET

E

LEGEND

- XXX.XX PROPOSED ELEVATION
- (XXX.XX) EXISTING ELEVATION
- HIGH SIDE CURB & GUTTER

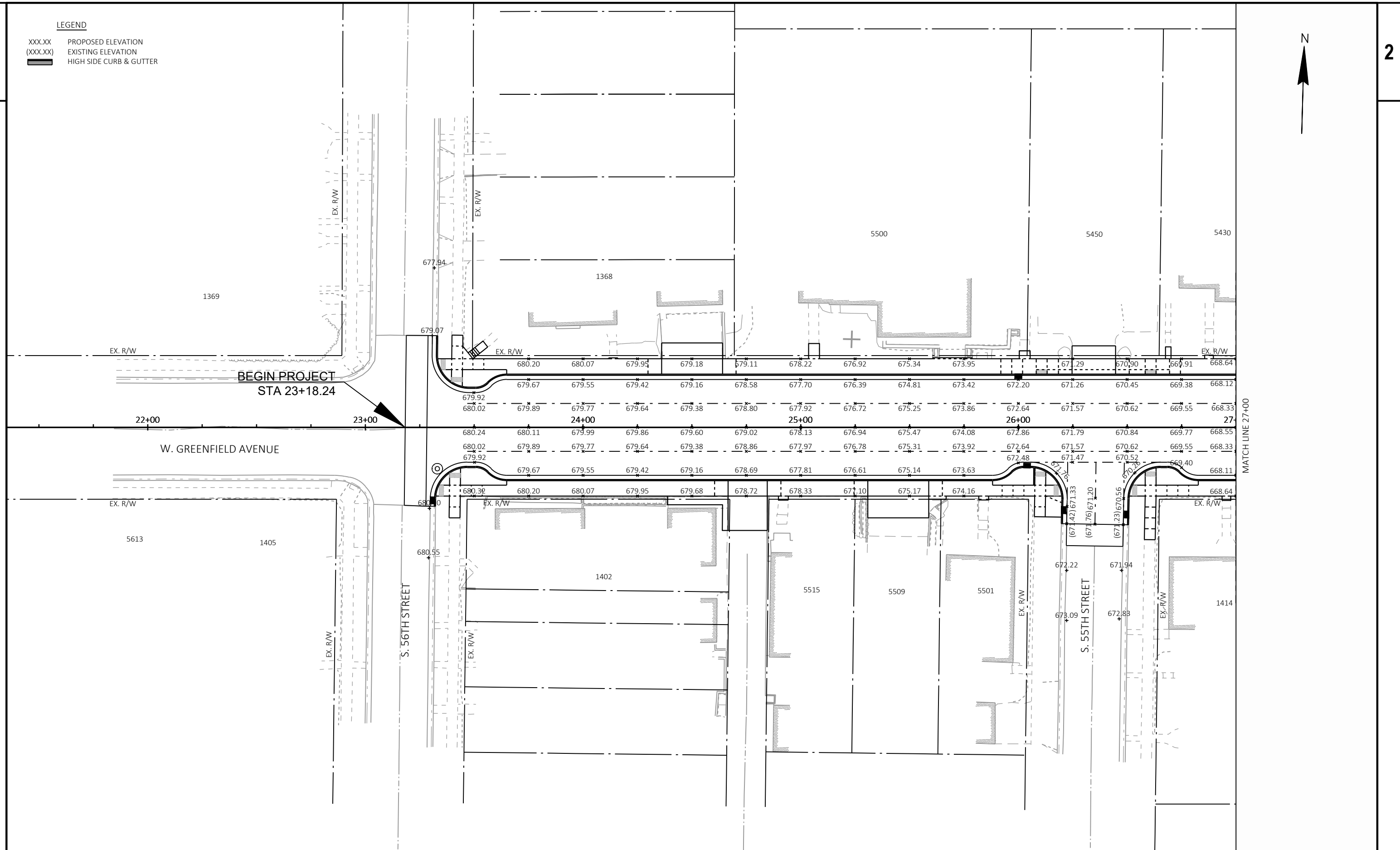

PROJECT NO: 2230-07-73

HWY: W. GREENFIELD AVENUE

COUNTY: MILWAUKEE

JOINT DETAILS

SHEET

E

LEGEND

- XXX.XX PROPOSED ELEVATION
- (XXX.XX) EXISTING ELEVATION
-  HIGH SIDE CURB & GUTTER

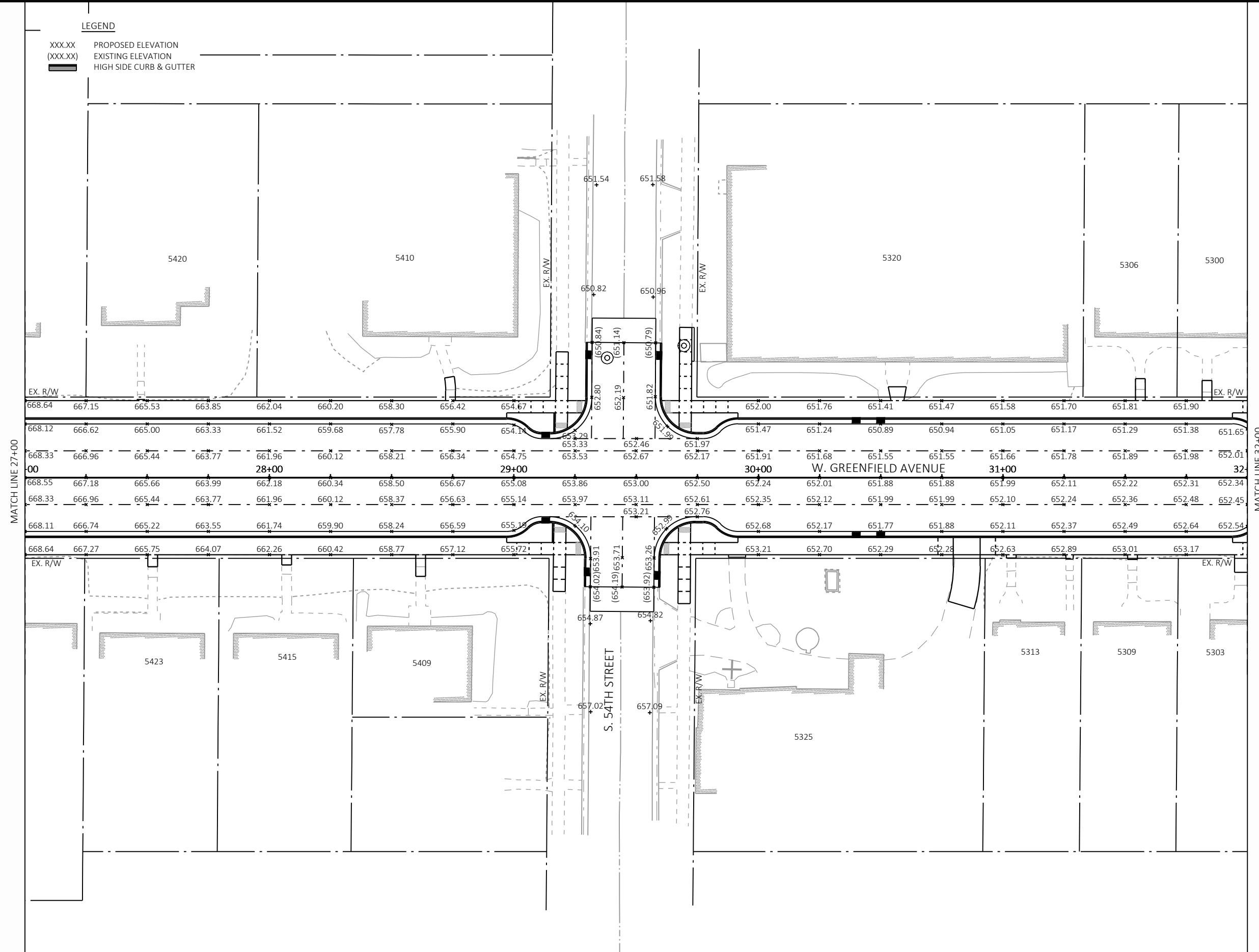

LEGEND
 XXX.XX PROPOSED ELEVATION
 (XXX.XX) EXISTING ELEVATION
 ——— HIGH SIDE CURB & GUTTER

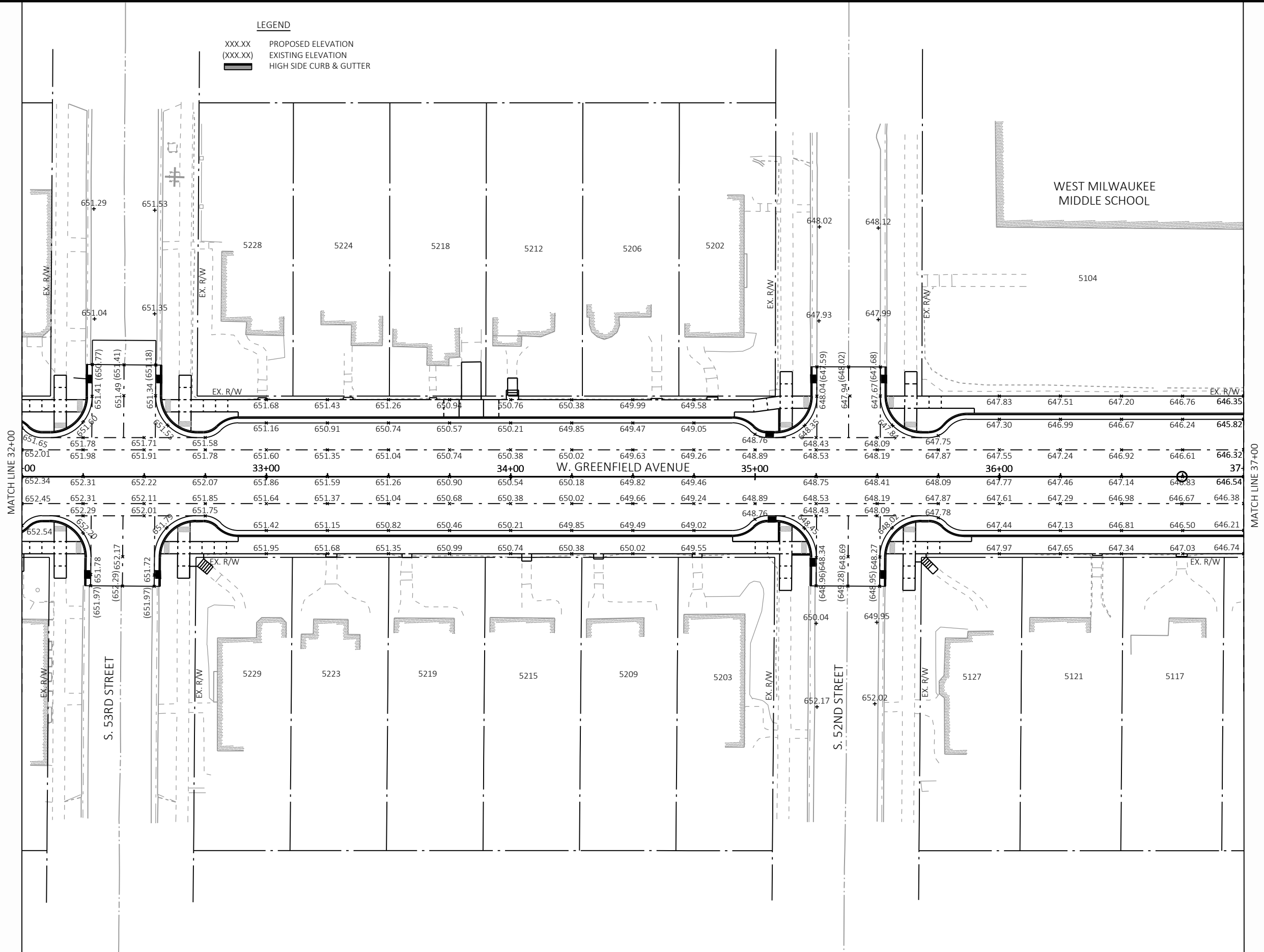

PROJECT NO: 2230-07-73

HWY: W. GREENFIELD AVENUE

COUNTY: MILWAUKEE

JOINT DETAILS

SHEET

E



LEGEND
 XXX.XX PROPOSED ELEVATION
 (XXX.XX) EXISTING ELEVATION
 [Symbol] HIGH SIDE CURB & GUTTER

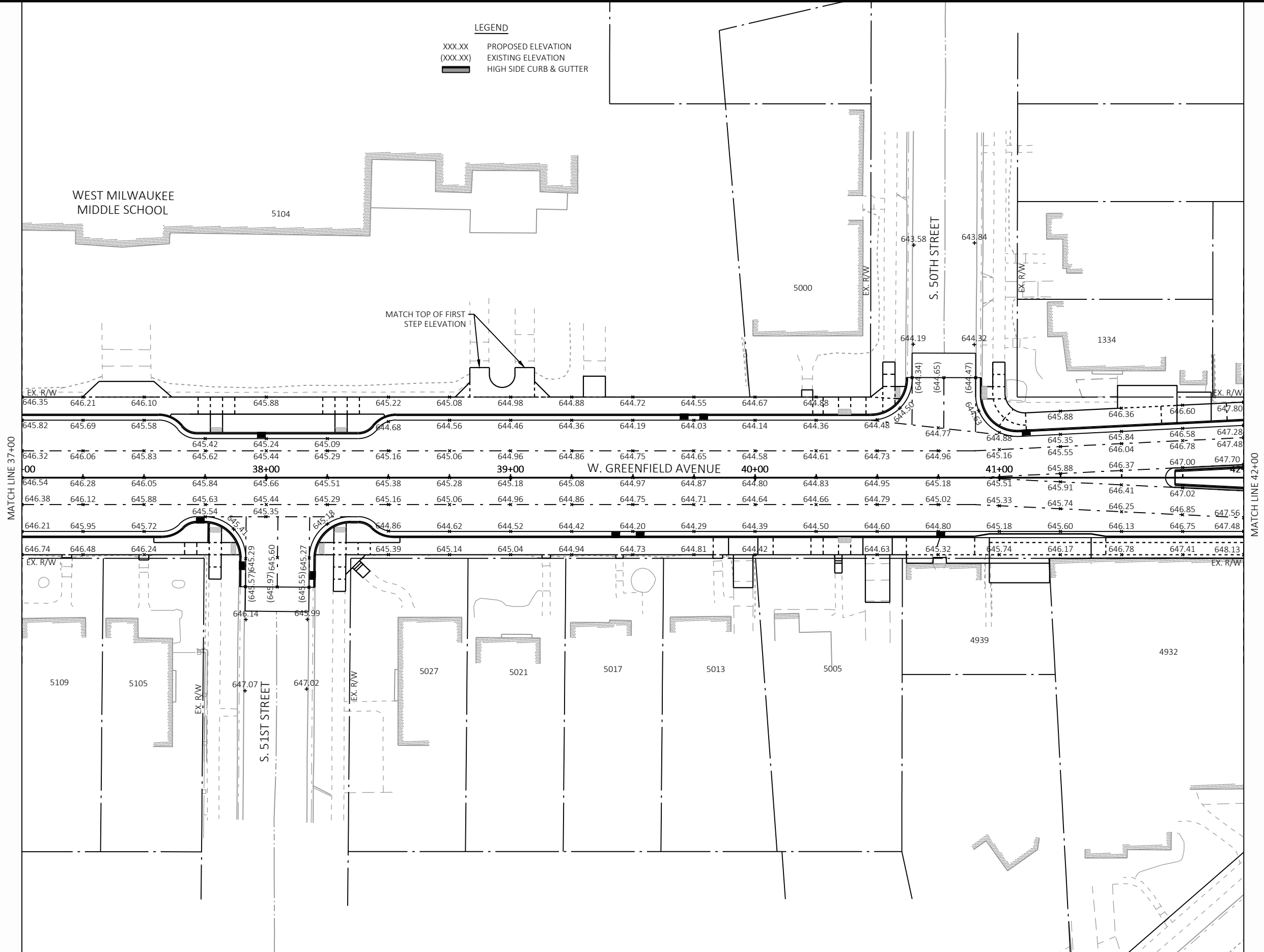

LEGEND
 XXX.XX PROPOSED ELEVATION
 (XXX.XX) EXISTING ELEVATION
 ——— HIGH SIDE CURB & GUTTER

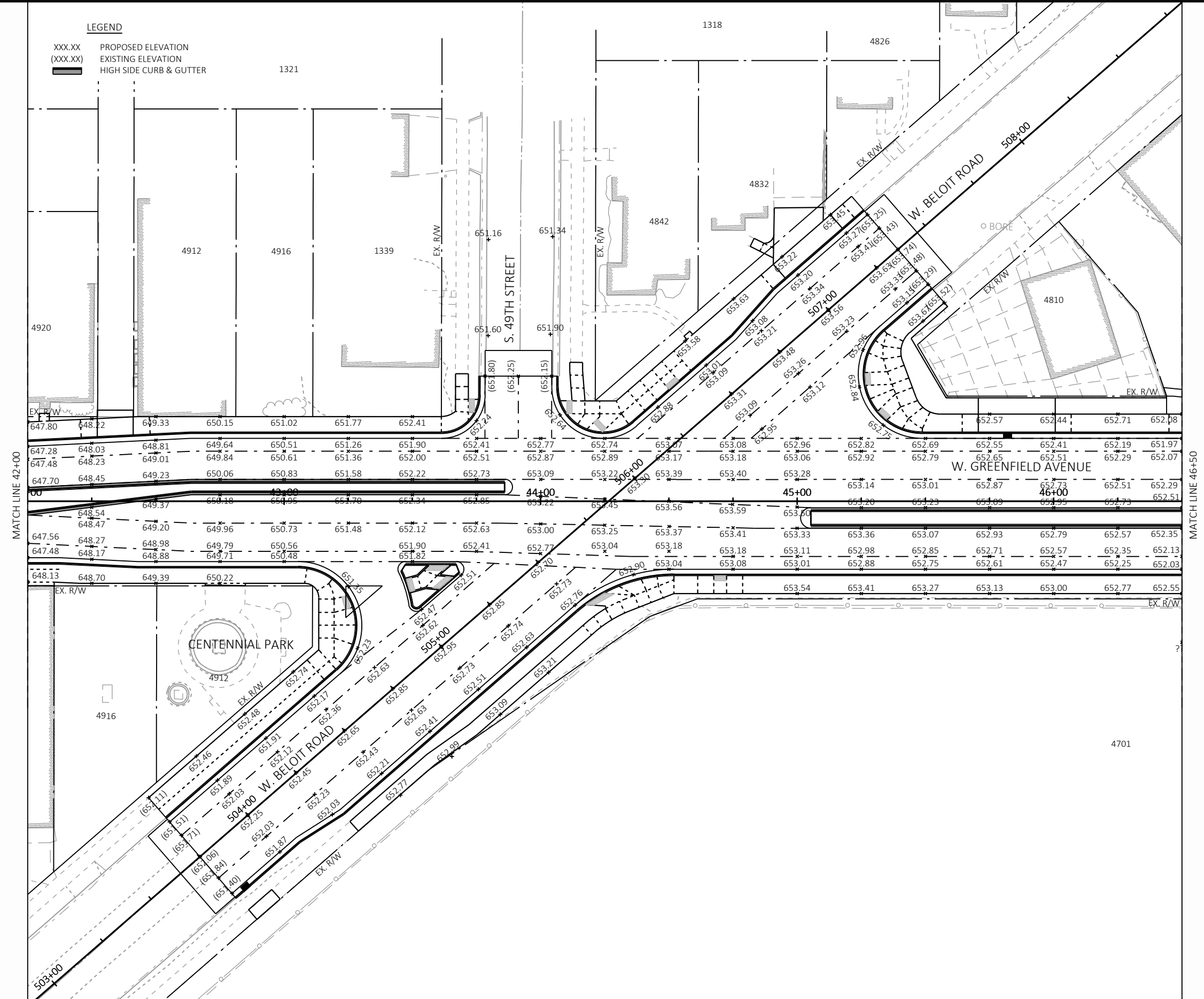

PROJECT NO: 2230-07-73

HWY: W. GREENFIELD AVENUE

COUNTY: MILWAUKEE

JOINT DETAILS

SHEET

E

LEGEND





- XXX.XX PROPOSED ELEVATION
- (XXX.XX) EXISTING ELEVATION
- █ HIGH SIDE CURB & GUTTER

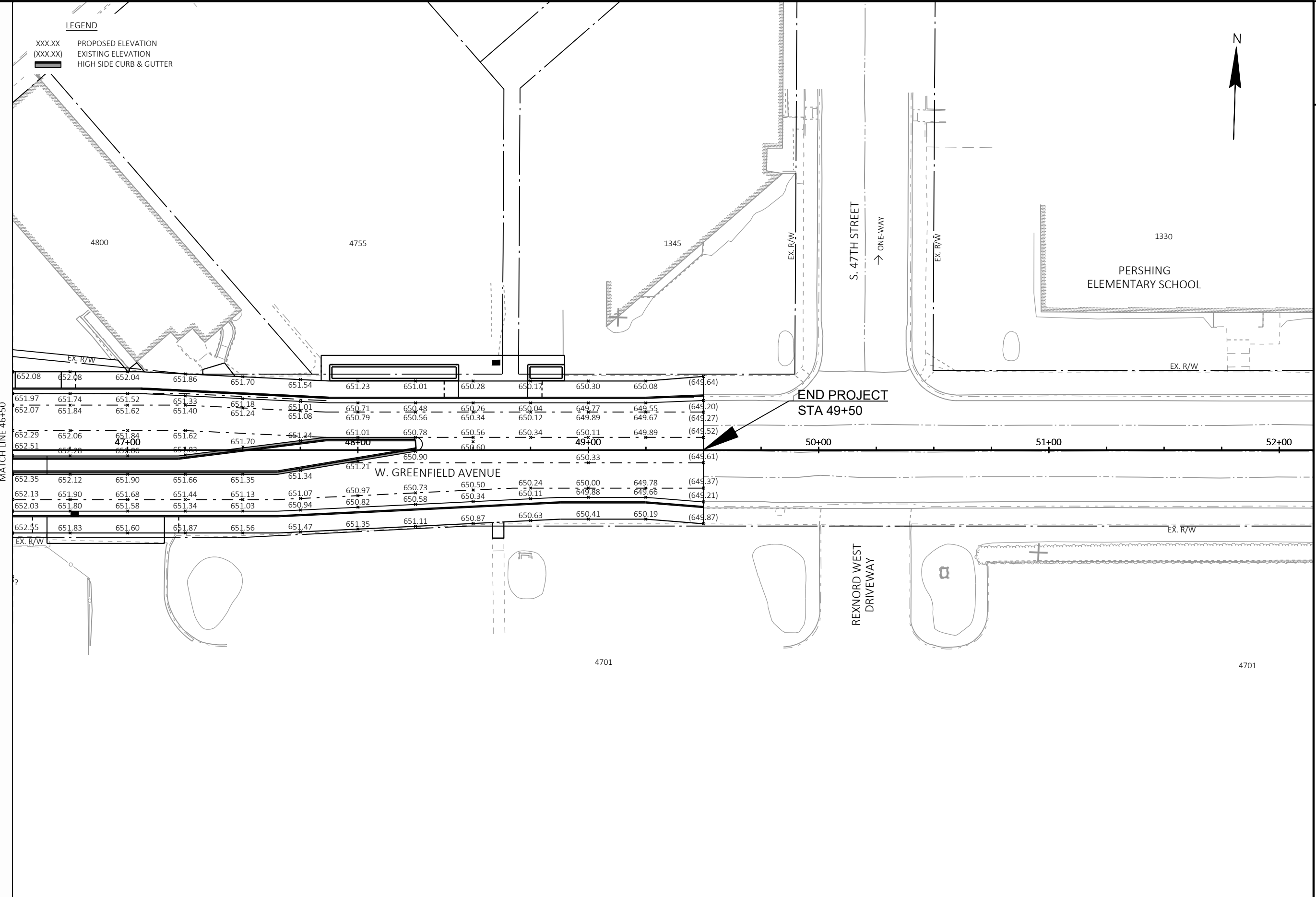

MATCH LINE 46+50





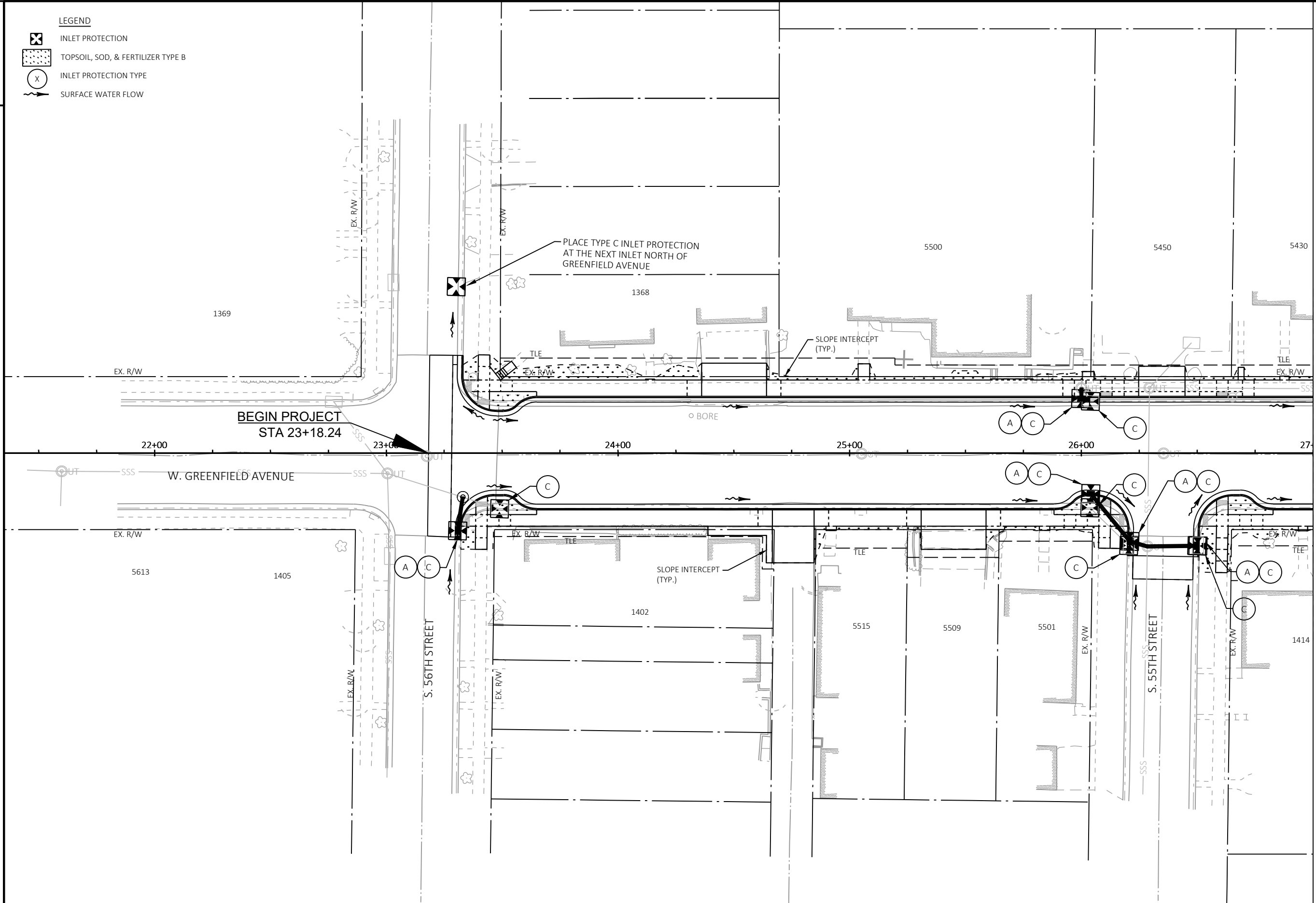

LEGEND

-  INLET PROTECTION
-  TOPSOIL, SOD, & FERTILIZER TYPE B
-  INLET PROTECTION TYPE
-  SURFACE WATER FLOW





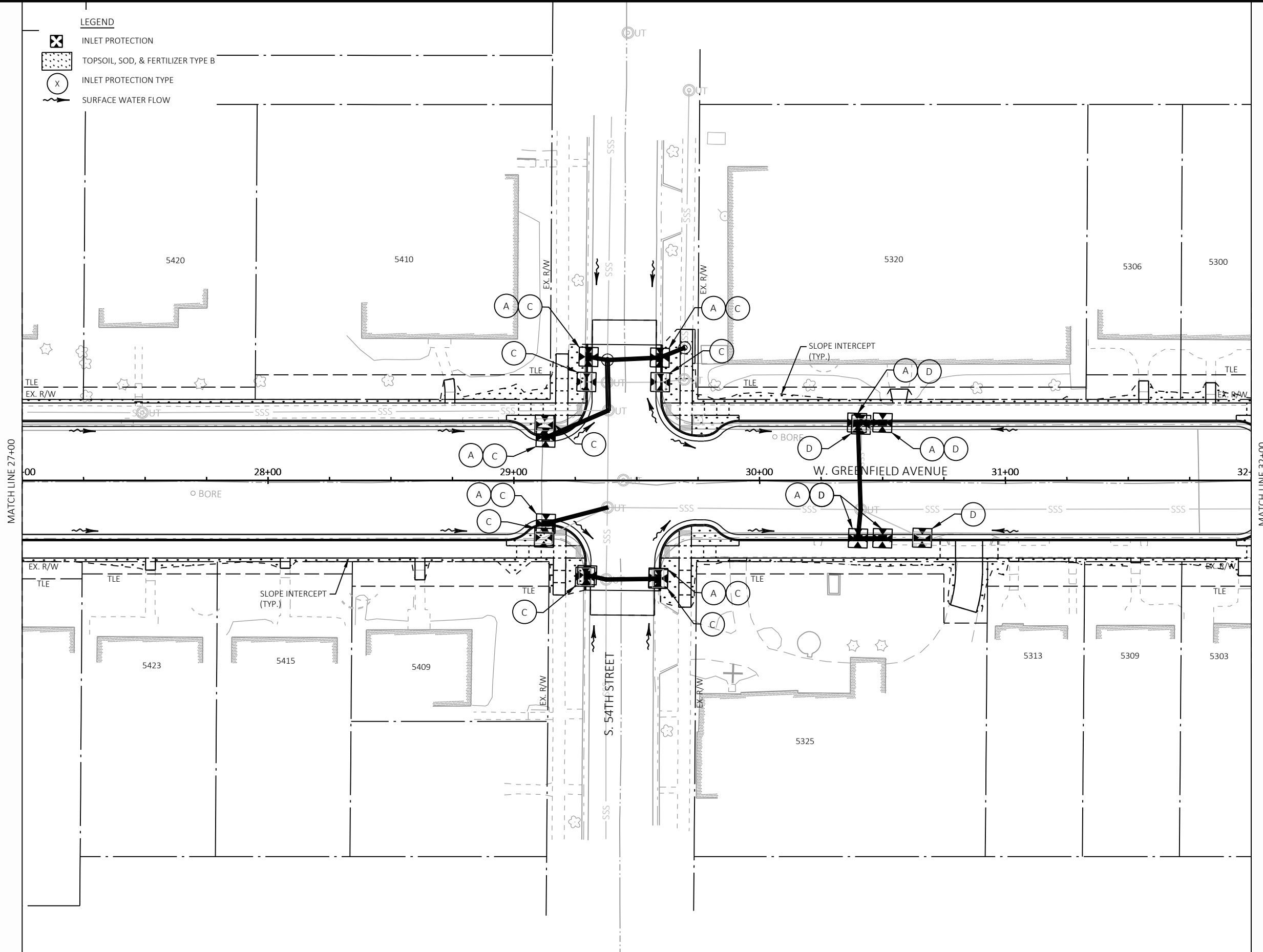

PROJECT NO: 2230-07-73	HWY: W. GREENFIELD AVENUE	COUNTY: MILWAUKEE	EROSION CONTROL	SHEET	E
------------------------	---------------------------	-------------------	-----------------	-------	----------

LEGEND

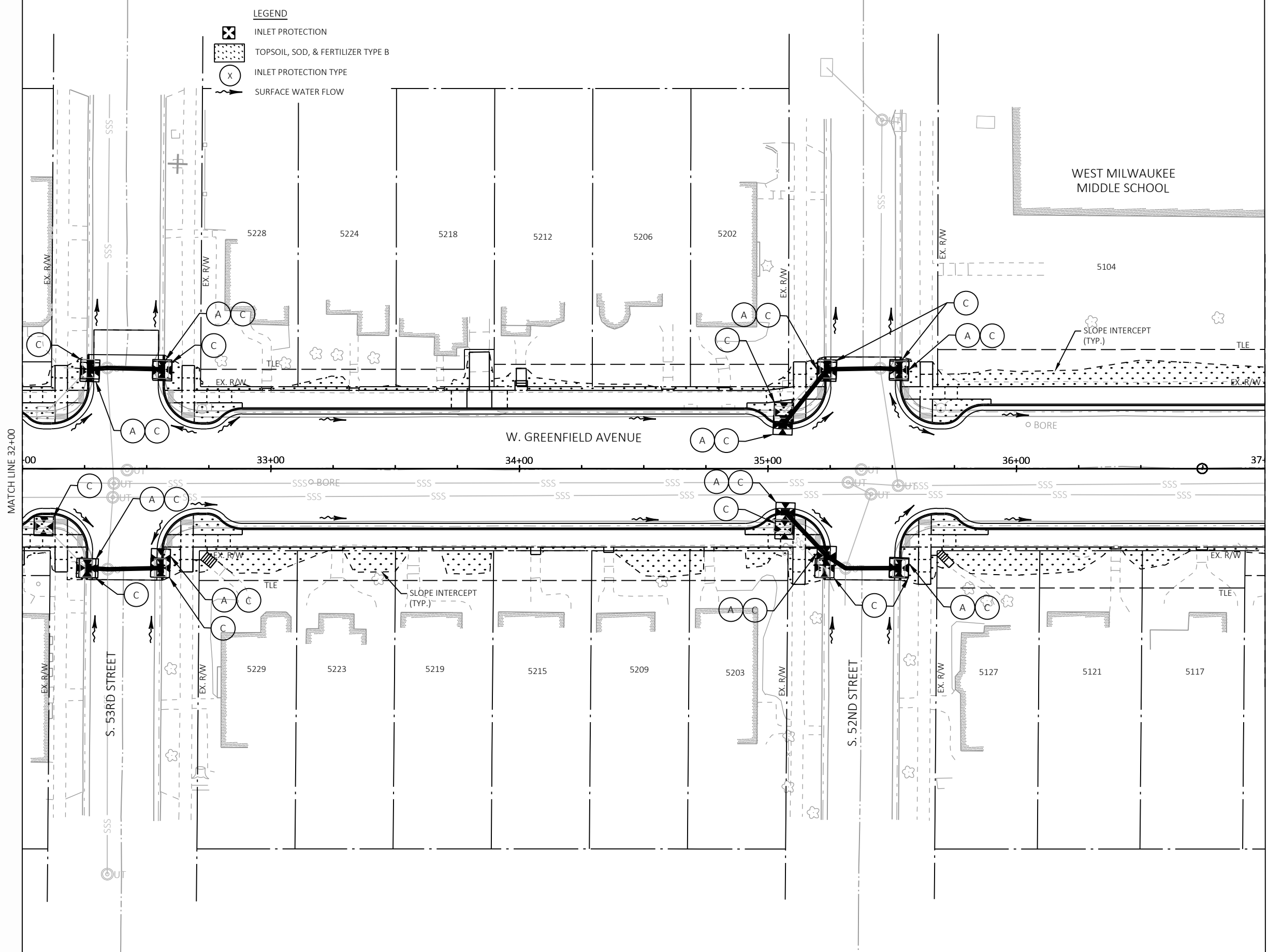
-  INLET PROTECTION
-  TOPSOIL, SOD, & FERTILIZER TYPE B
-  INLET PROTECTION TYPE
-  SURFACE WATER FLOW





- LEGEND**
-  INLET PROTECTION
 -  TOPSOIL, SOD, & FERTILIZER TYPE B
 -  INLET PROTECTION TYPE
 -  SURFACE WATER FLOW

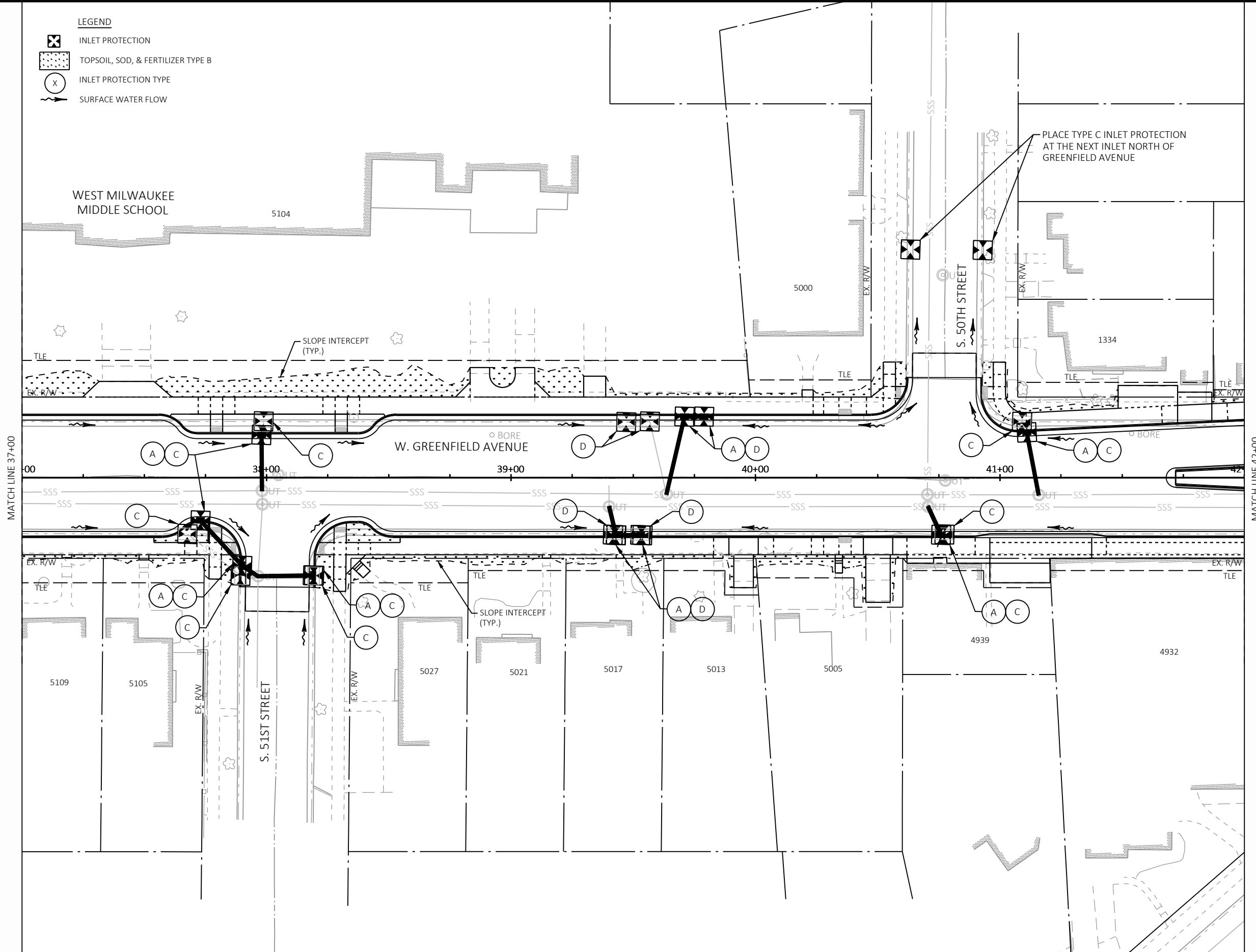

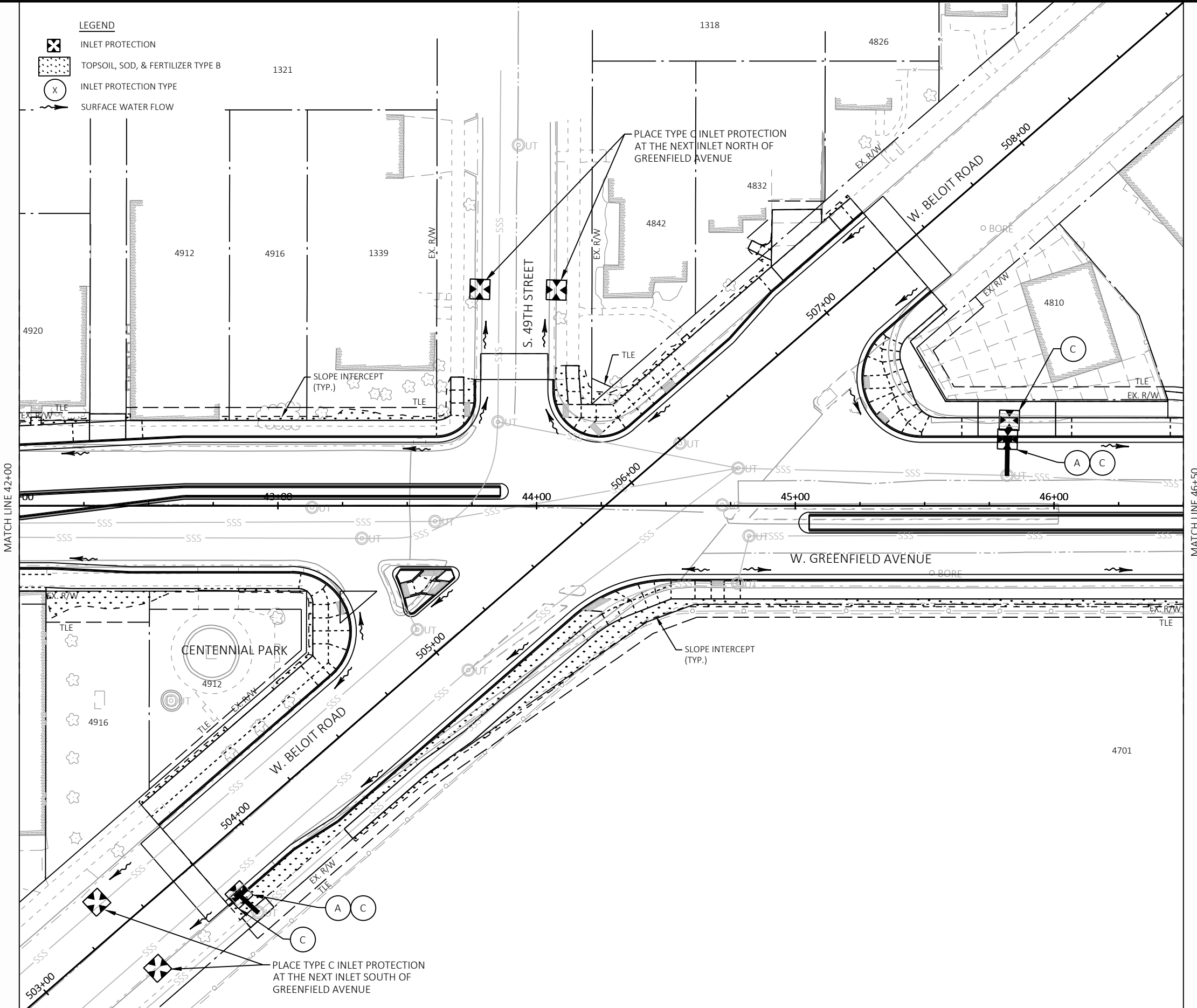

- LEGEND**
- INLET PROTECTION
 - TOPSOIL, SOD, & FERTILIZER TYPE B
 - INLET PROTECTION TYPE
 - SURFACE WATER FLOW

PROJECT NO: 2230-07-73

HWY: W. GREENFIELD AVENUE

COUNTY: MILWAUKEE

EROSION CONTROL

SHEET

E

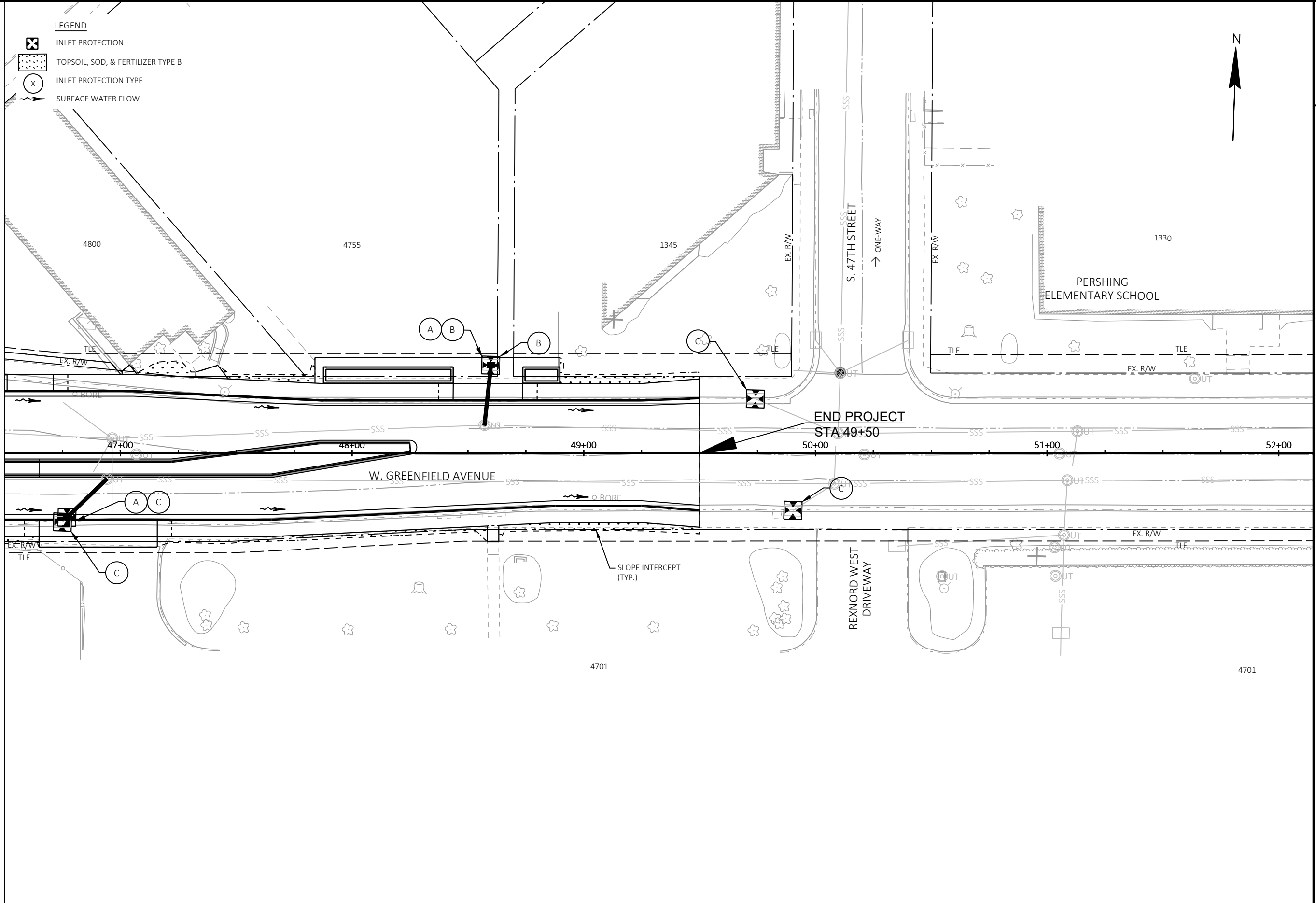

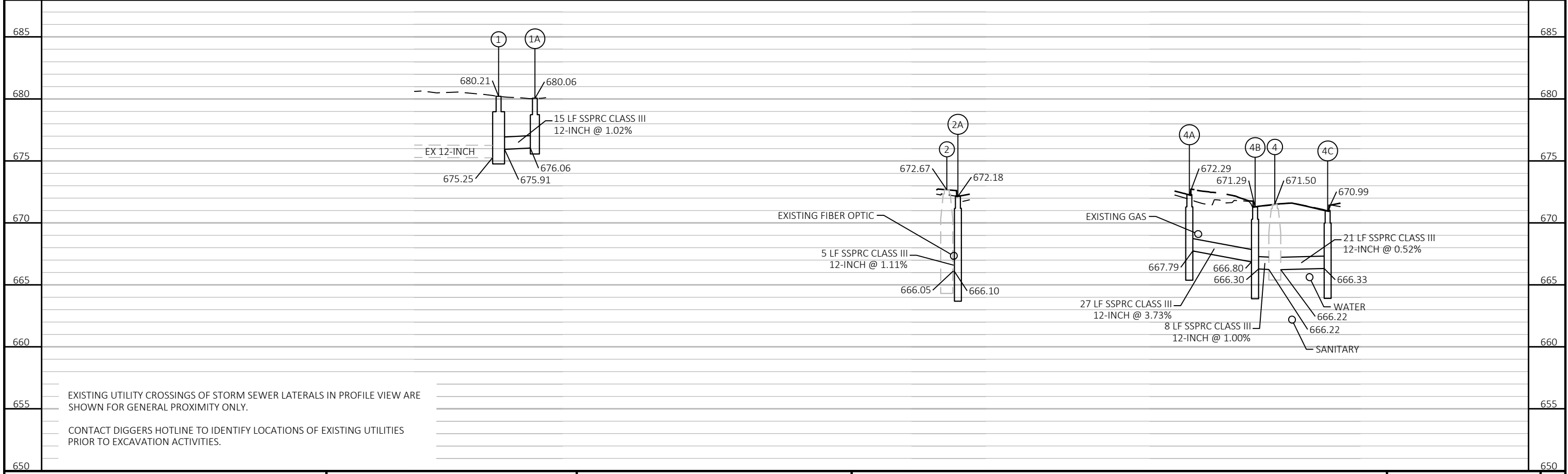
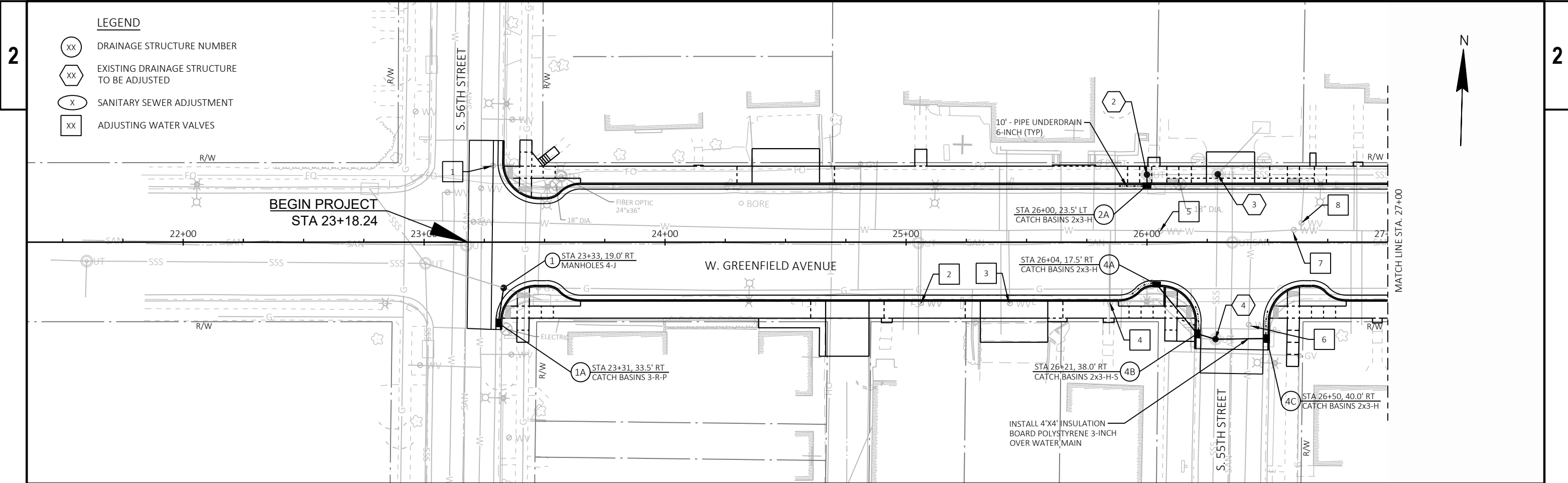

EXISTING UTILITY CROSSINGS OF STORM SEWER LATERALS IN PROFILE VIEW ARE SHOWN FOR GENERAL PROXIMITY ONLY.

CONTACT DIGGERS HOTLINE TO IDENTIFY LOCATIONS OF EXISTING UTILITIES PRIOR TO EXCAVATION ACTIVITIES.

LEGEND

- (XX) DRAINAGE STRUCTURE NUMBER
- (XX) EXISTING DRAINAGE STRUCTURE TO BE ADJUSTED
- (X) SANITARY SEWER ADJUSTMENT
- (XX) ADJUSTING WATER VALVES

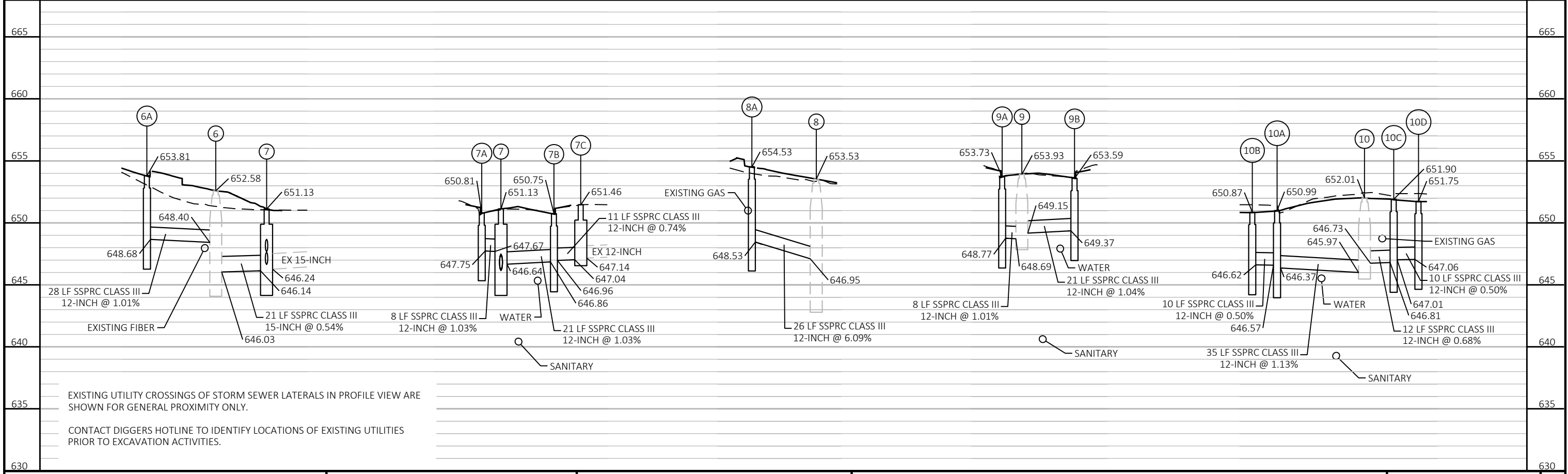
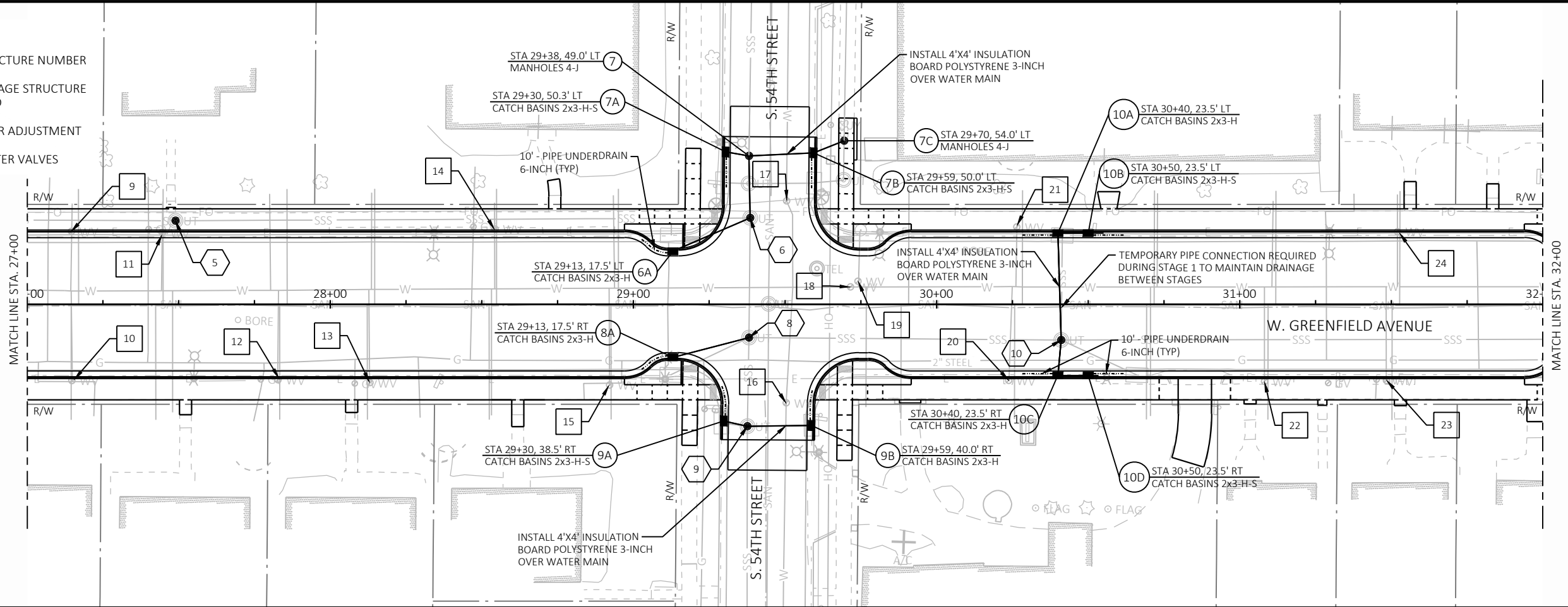

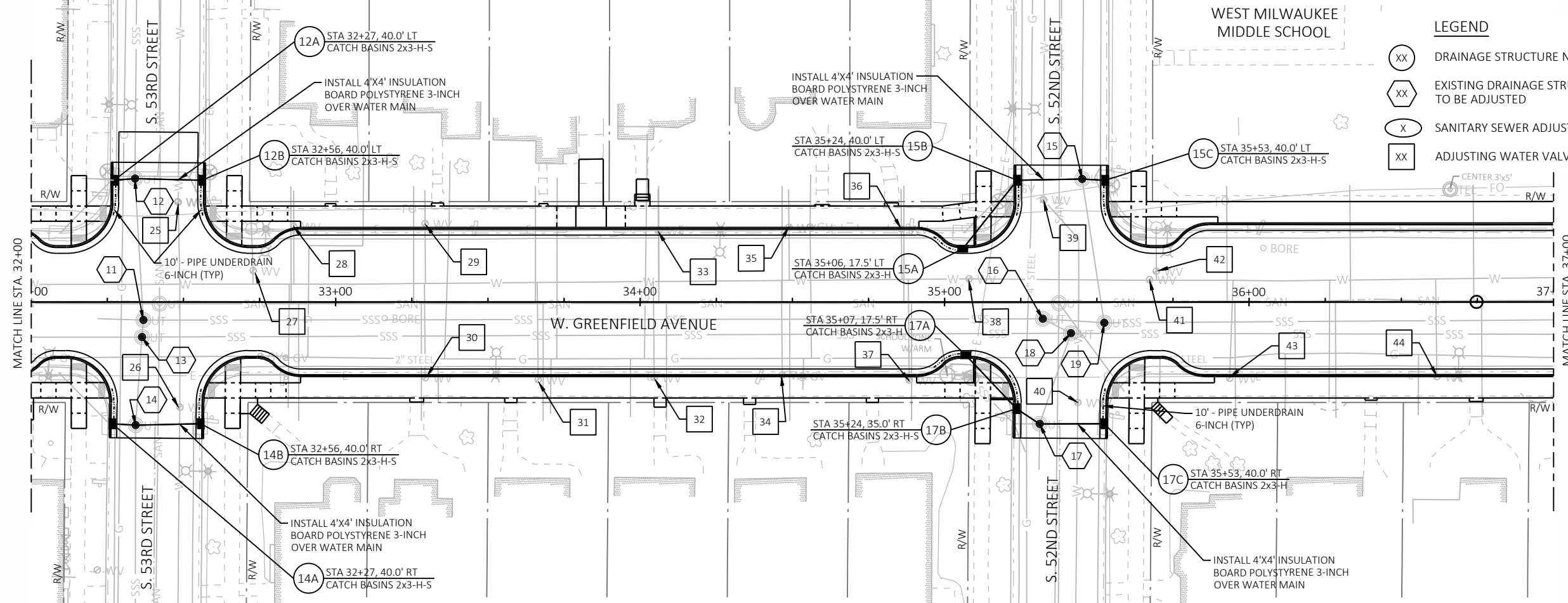

LEGEND

- XX DRAINAGE STRUCTURE NUMBER
- XX EXISTING DRAINAGE STRUCTURE TO BE ADJUSTED
- X SANITARY SEWER ADJUSTMENT
- XX ADJUSTING WATER VALVES

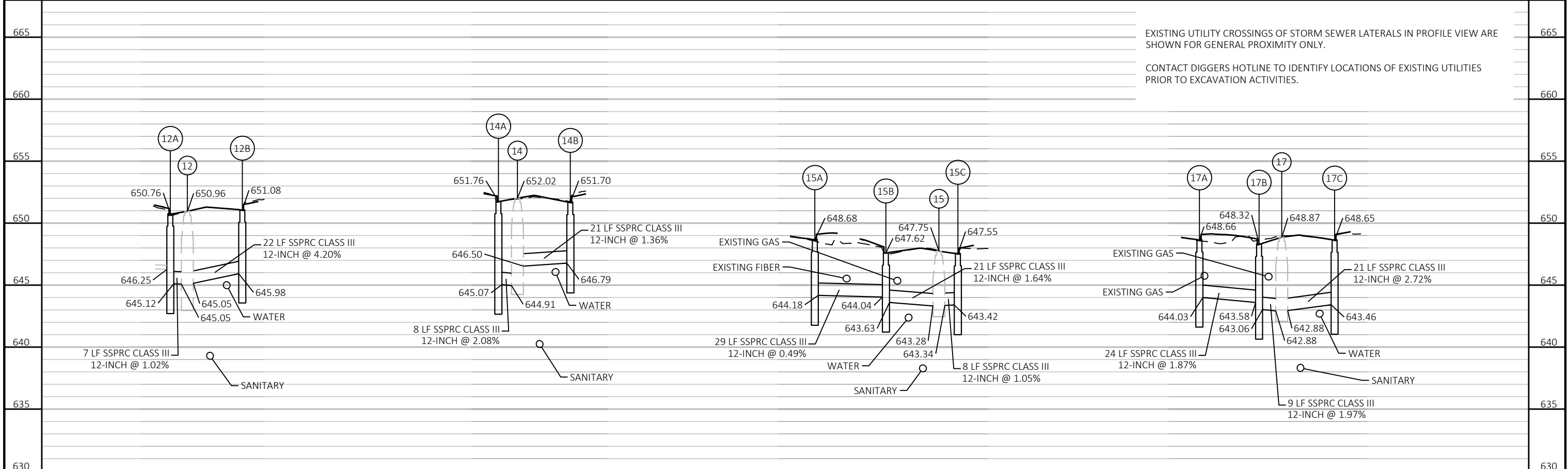

PROJECT NO: 2230-07-73	HWY: W. GREENFIELD AVENUE	COUNTY: MILWAUKEE	STORM SEWER	SHEET	E
------------------------	---------------------------	-------------------	-------------	-------	----------

LEGEND

- XX DRAINAGE STRUCTURE NUMBER
- XX EXISTING DRAINAGE STRUCTURE TO BE ADJUSTED
- X SANITARY SEWER ADJUSTMENT
- XX ADJUSTING WATER VALVES

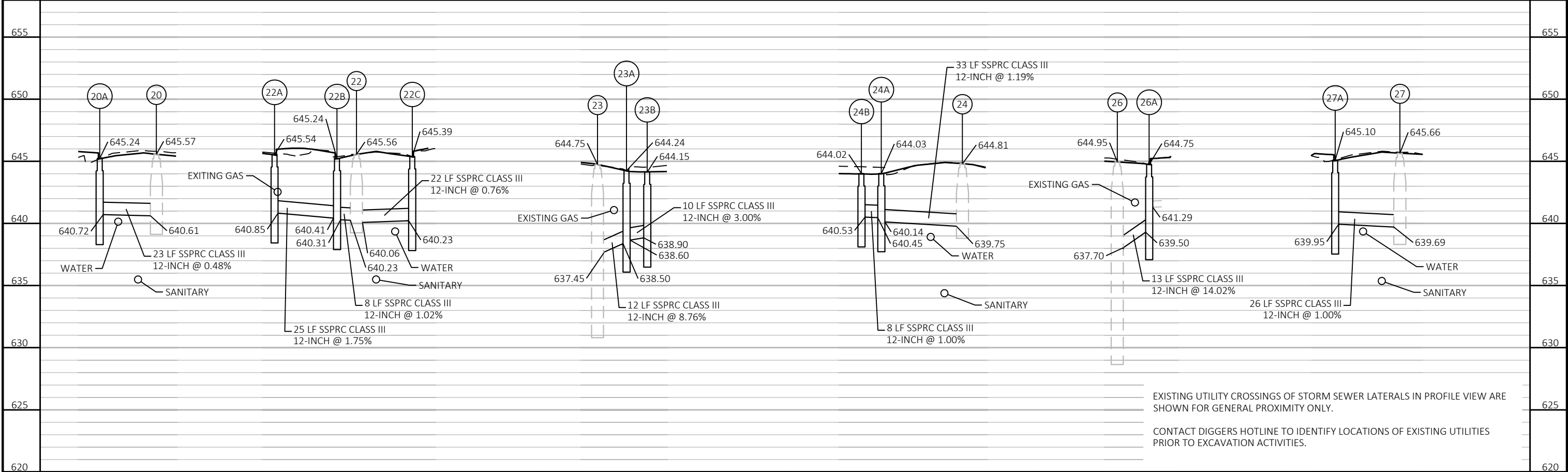
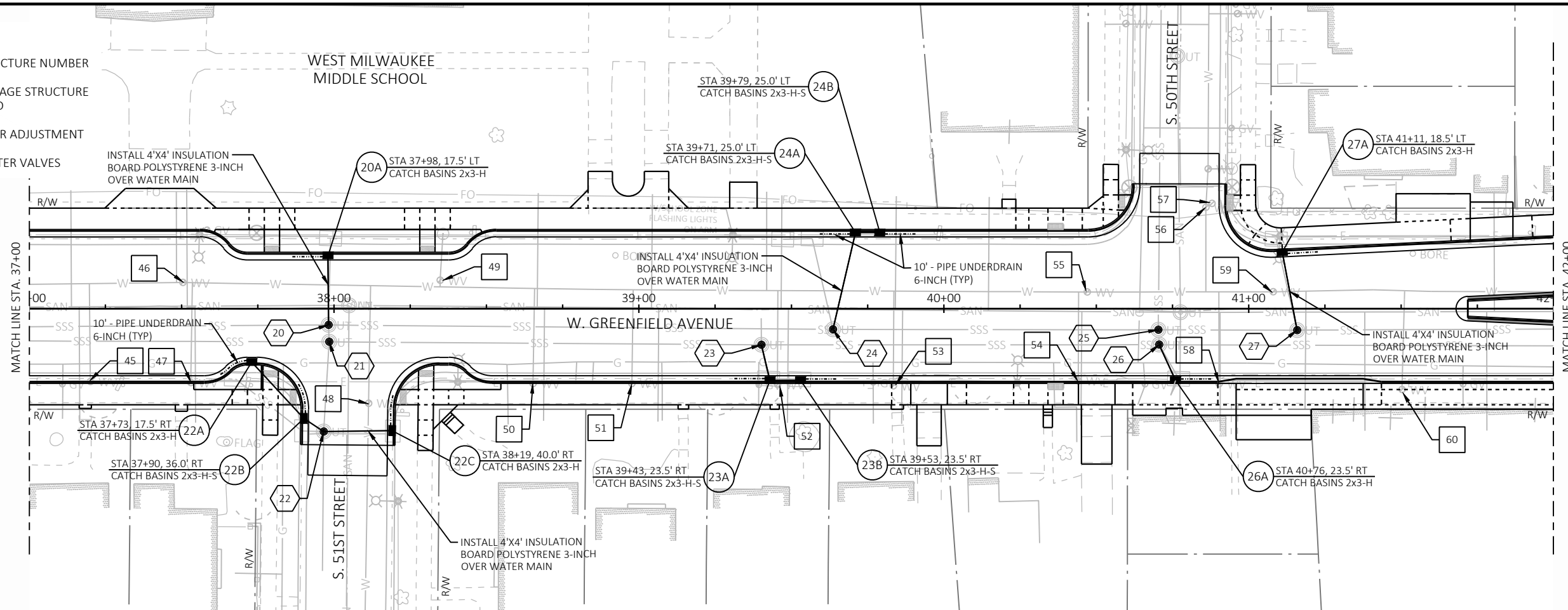

LEGEND

- XX DRAINAGE STRUCTURE NUMBER
- XX EXISTING DRAINAGE STRUCTURE TO BE ADJUSTED
- X SANITARY SEWER ADJUSTMENT
- XX ADJUSTING WATER VALVES

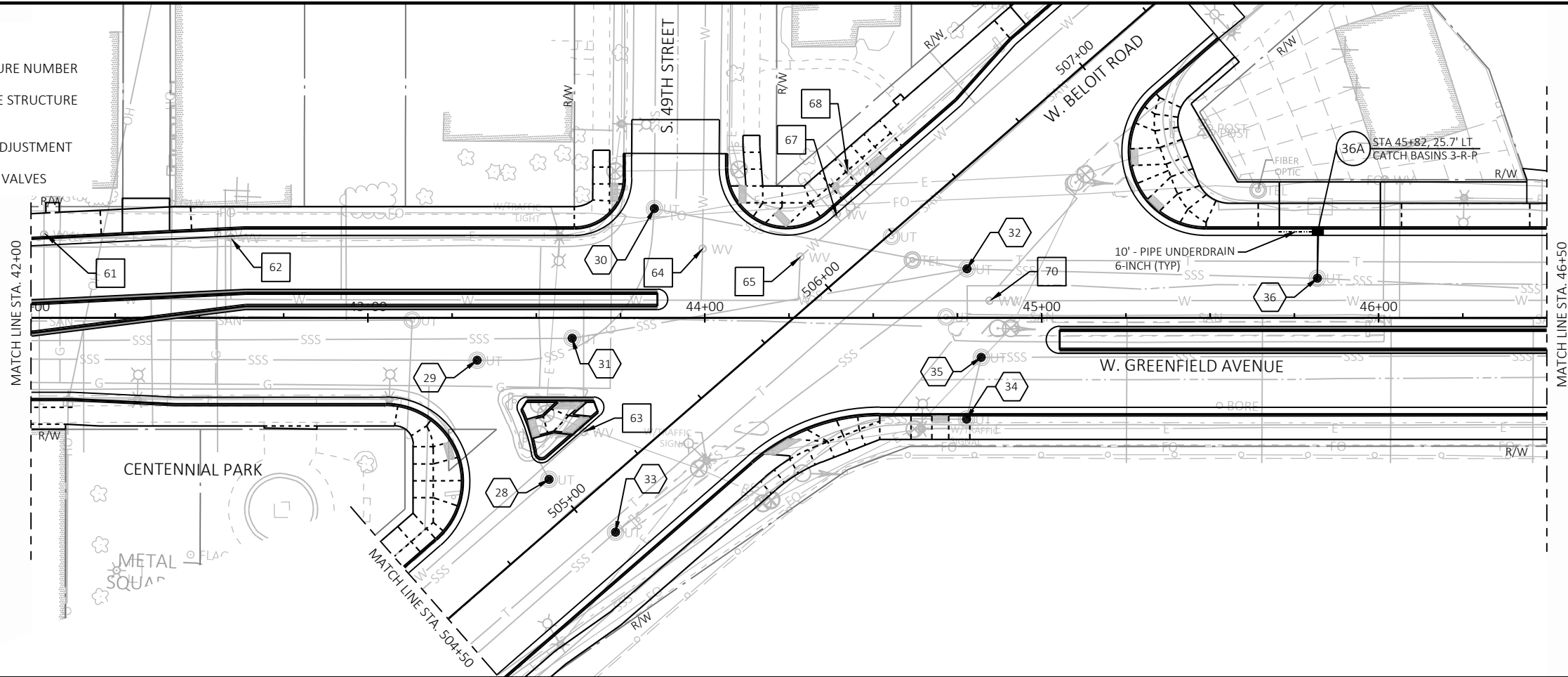

PROJECT NO: 2230-07-73	HWY: W. GREENFIELD AVENUE	COUNTY: MILWAUKEE	STORM SEWER	SHEET	E
------------------------	---------------------------	-------------------	-------------	-------	----------

LEGEND

- XX DRAINAGE STRUCTURE NUMBER
- XX EXISTING DRAINAGE STRUCTURE TO BE ADJUSTED
- X SANITARY SEWER ADJUSTMENT
- XX ADJUSTING WATER VALVES

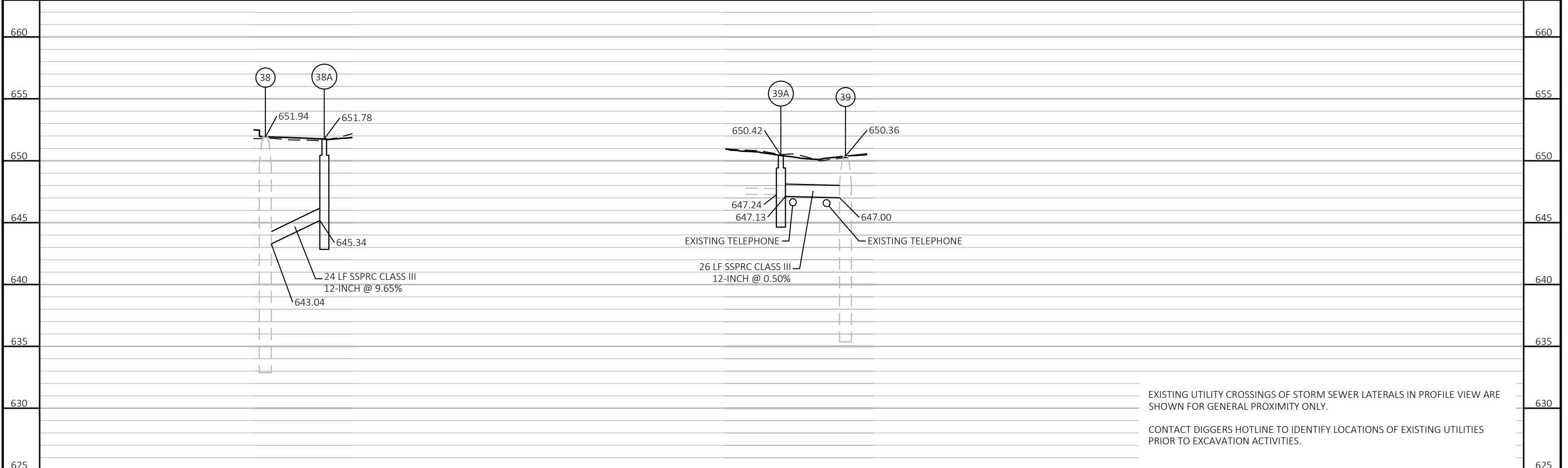
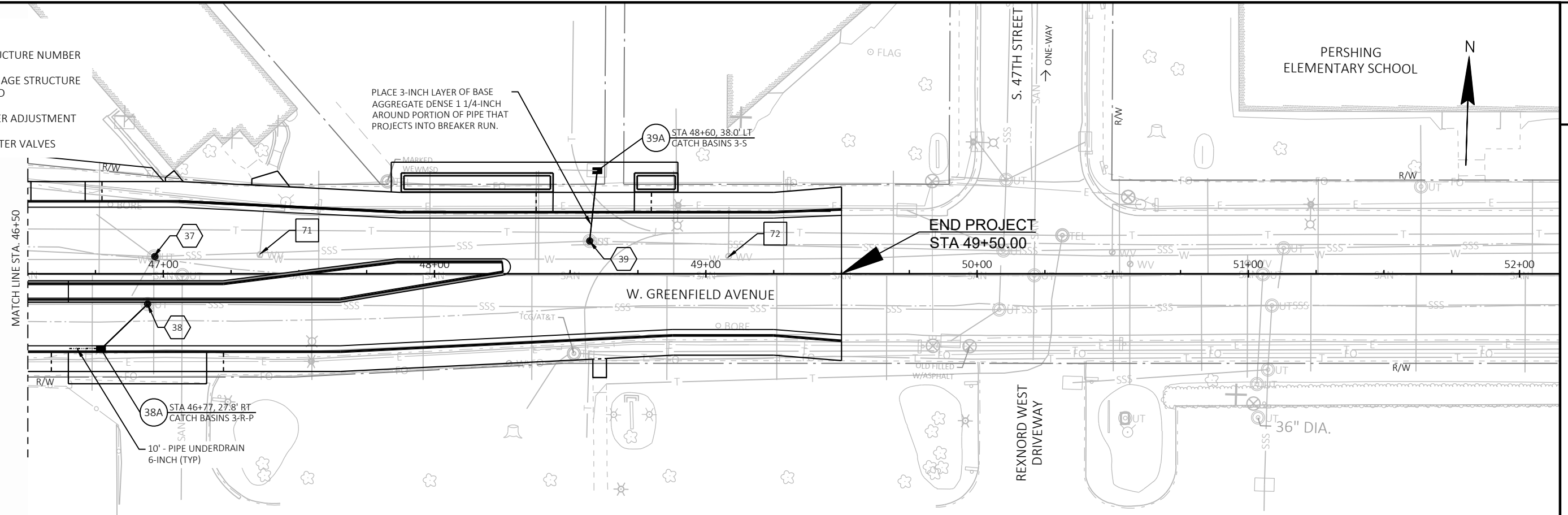

EXISTING UTILITY CROSSINGS OF STORM SEWER LATERALS IN PROFILE VIEW ARE SHOWN FOR GENERAL PROXIMITY ONLY.

CONTACT DIGGERS HOTLINE TO IDENTIFY LOCATIONS OF EXISTING UTILITIES PRIOR TO EXCAVATION ACTIVITIES.

LEGEND

- (XX) DRAINAGE STRUCTURE NUMBER
- (XX) EXISTING DRAINAGE STRUCTURE TO BE ADJUSTED
- (X) SANITARY SEWER ADJUSTMENT
- (XX) ADJUSTING WATER VALVES

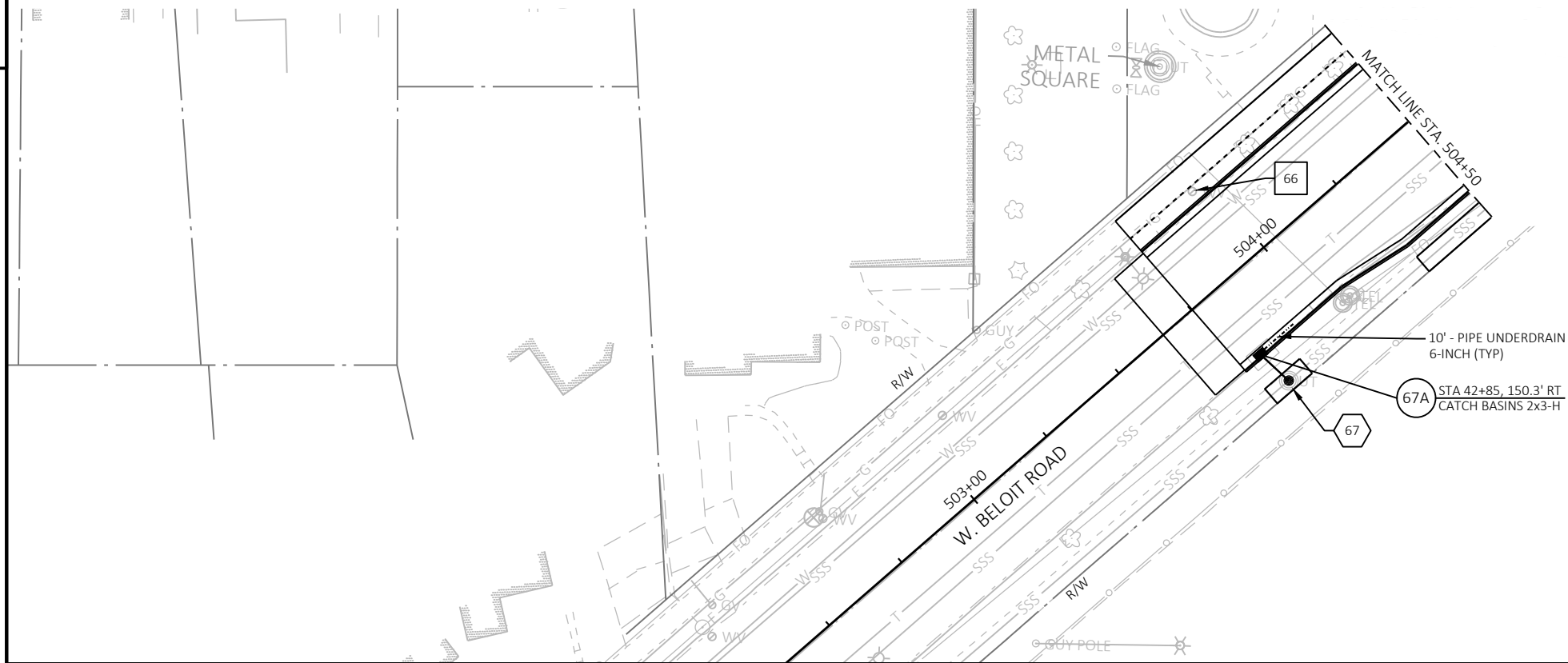

EXISTING UTILITY CROSSINGS OF STORM SEWER LATERALS IN PROFILE VIEW ARE SHOWN FOR GENERAL PROXIMITY ONLY.

CONTACT DIGGERS HOTLINE TO IDENTIFY LOCATIONS OF EXISTING UTILITIES PRIOR TO EXCAVATION ACTIVITIES.

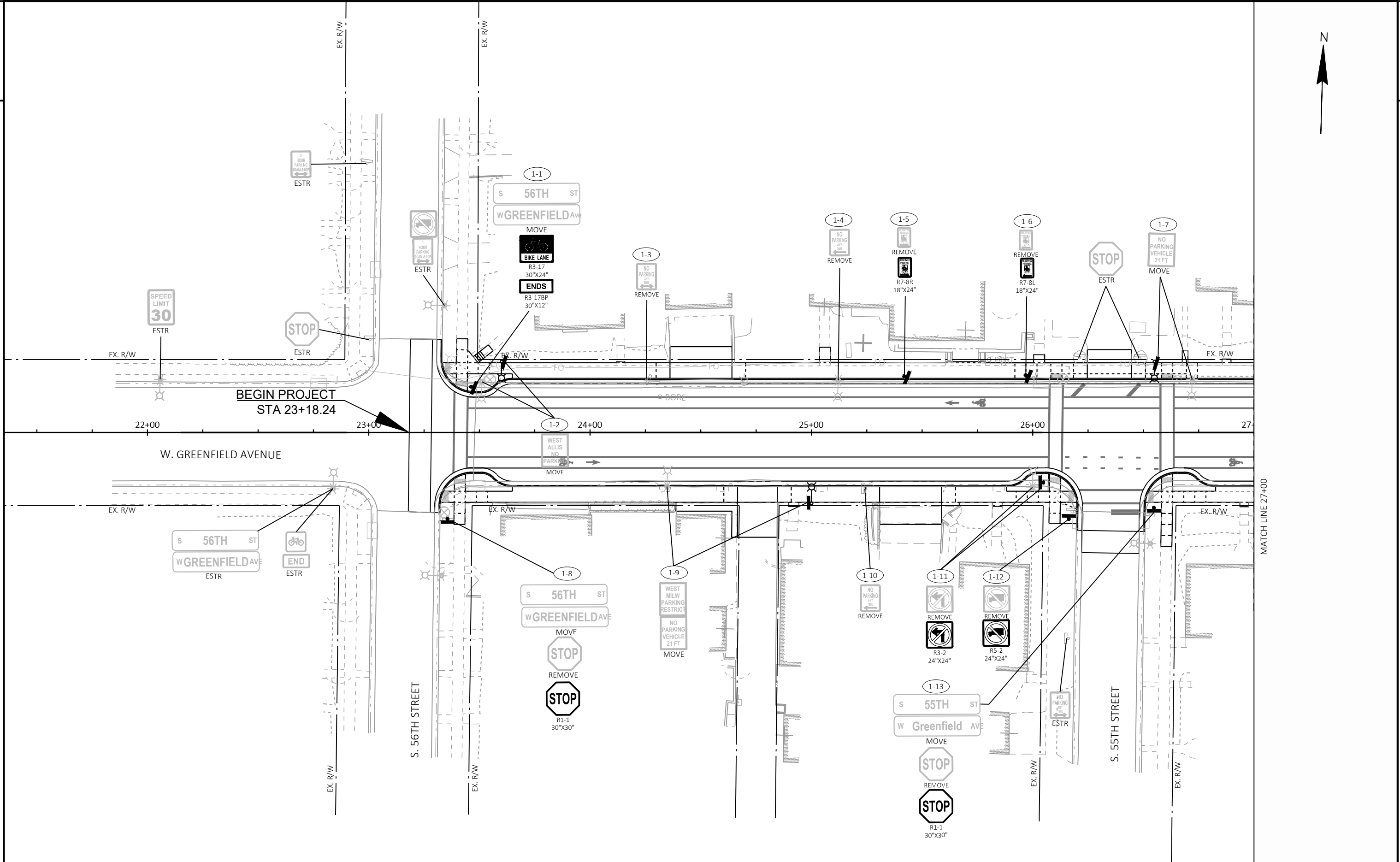

PROJECT NO: 2230-07-73	HWY: W. GREENFIELD AVENUE	COUNTY: MILWAUKEE	PERMANENT SIGNING	SHEET	E
------------------------	---------------------------	-------------------	-------------------	-------	----------

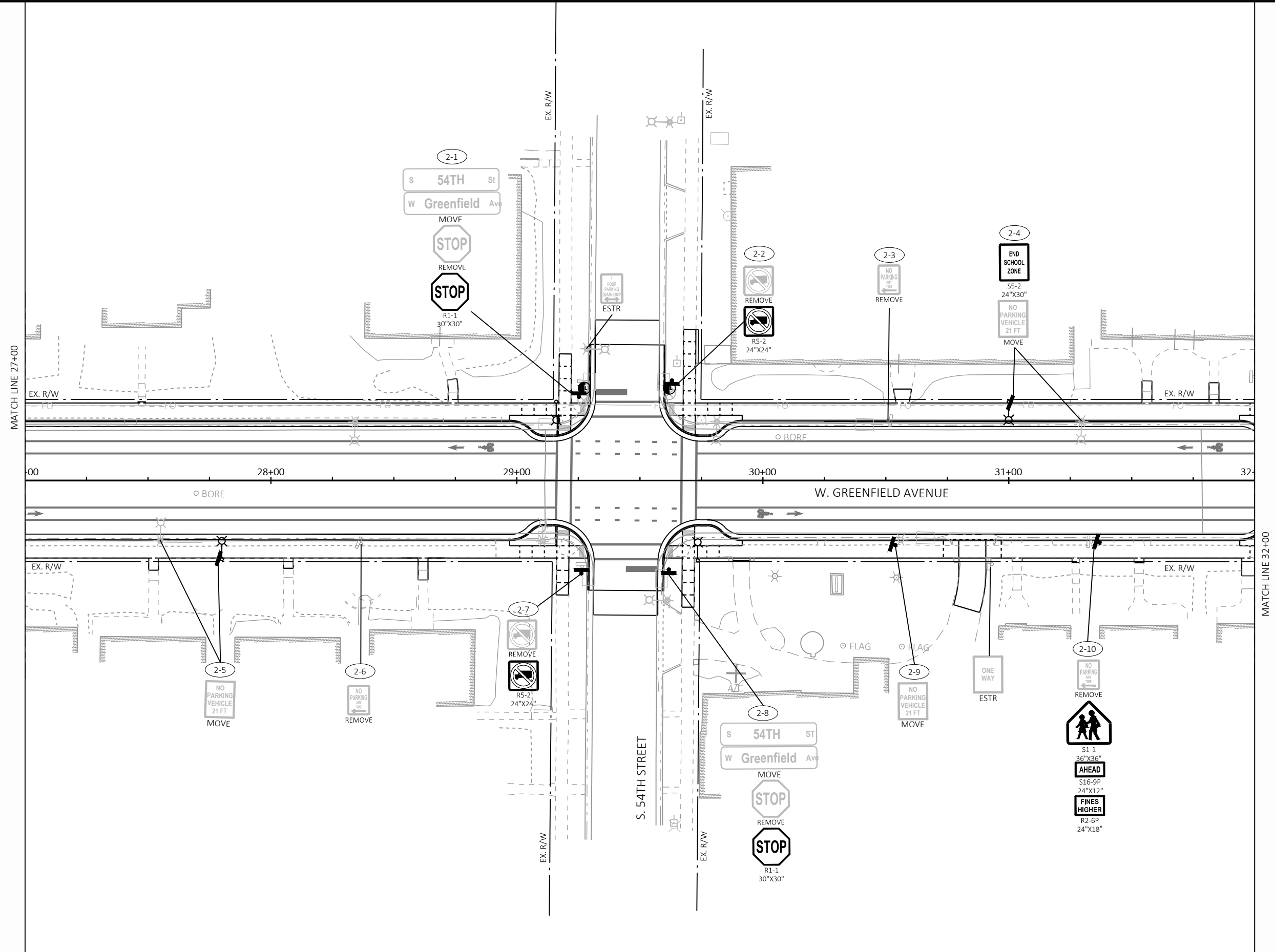

PROJECT NO: 2230-07-73	HWY: W. GREENFIELD AVENUE	COUNTY: MILWAUKEE	PERMANENT SIGNING	SHEET	E
------------------------	---------------------------	-------------------	-------------------	-------	----------

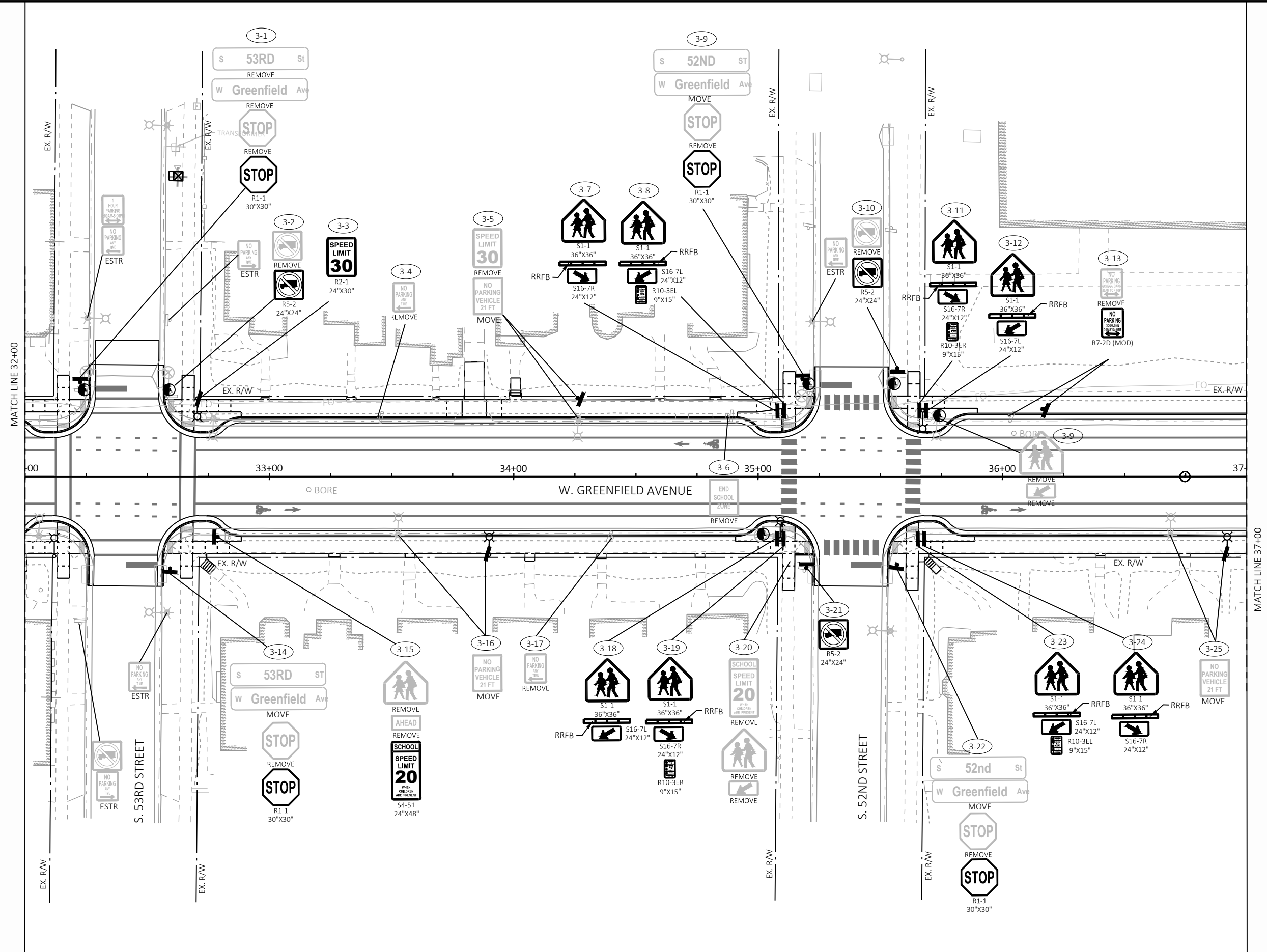

PROJECT NO: 2230-07-73

HWY: W. GREENFIELD AVENUE

COUNTY: MILWAUKEE

PERMANENT SIGNING

SHEET

E

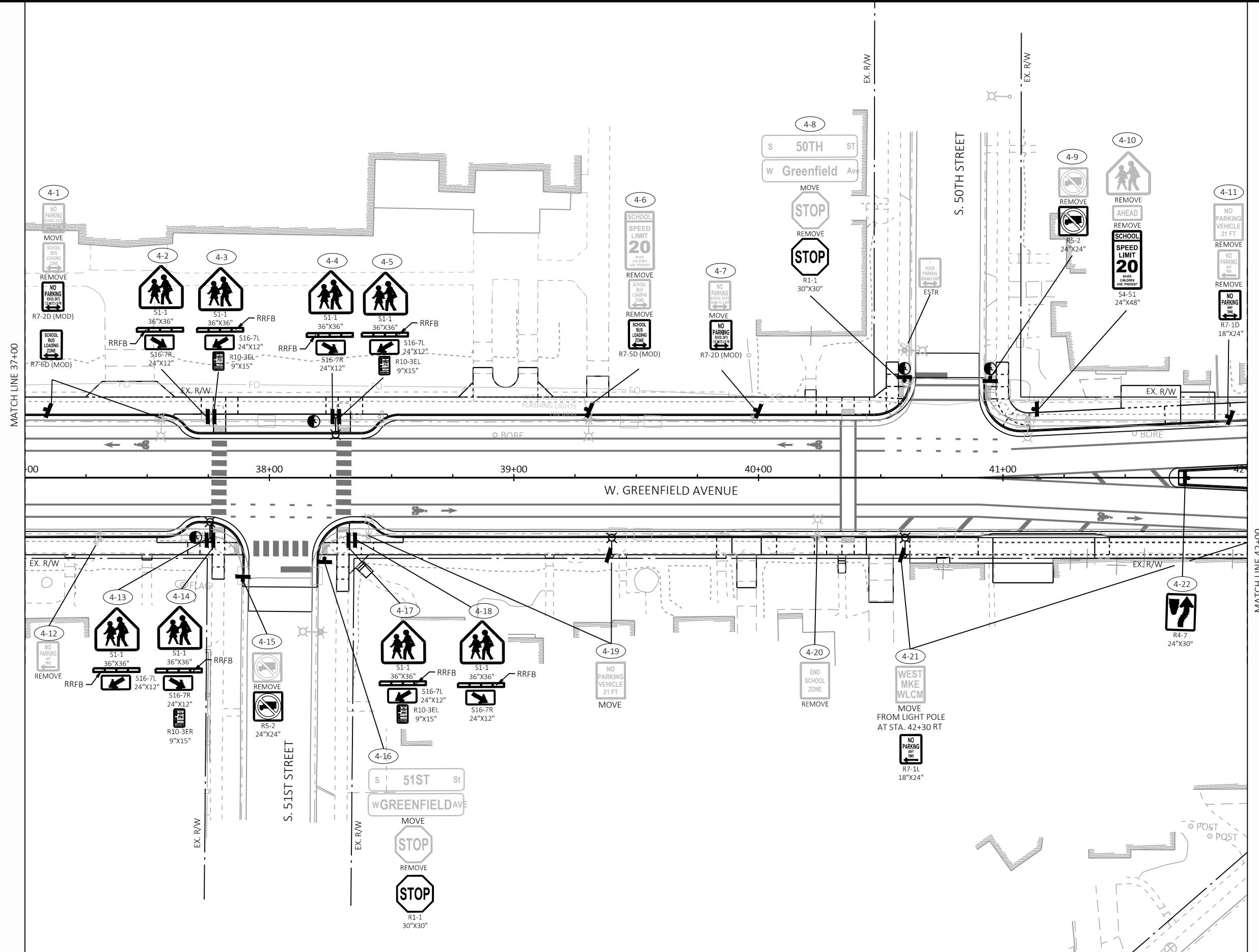

PROJECT NO: 2230-07-73

HWY: W. GREENFIELD AVENUE

COUNTY: MILWAUKEE

PERMANENT SIGNING

SHEET

E

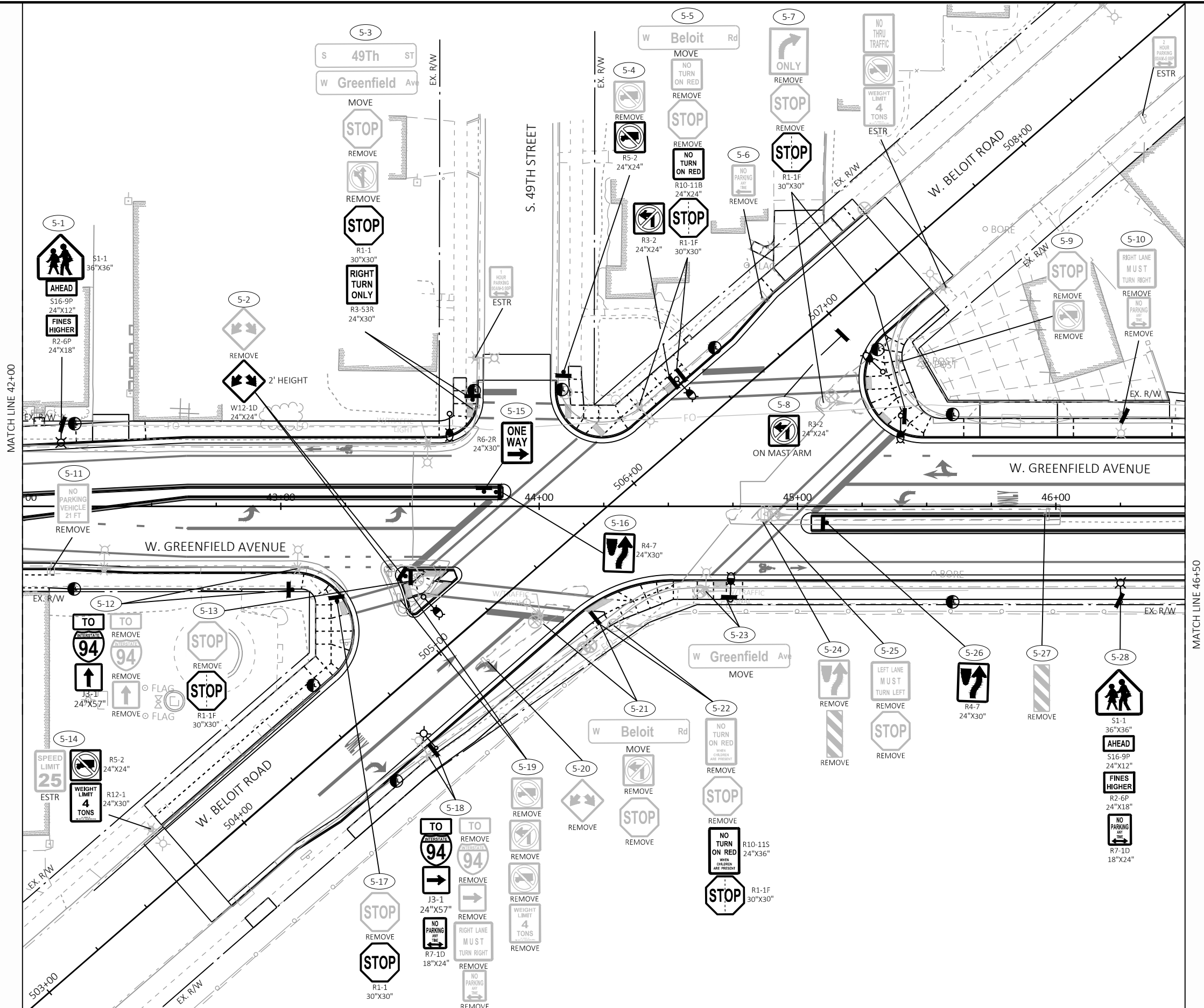

PROJECT NO: 2230-07-73

HWY: W. GREENFIELD AVENUE

COUNTY: MILWAUKEE

PERMANENT SIGNING

SHEET

E

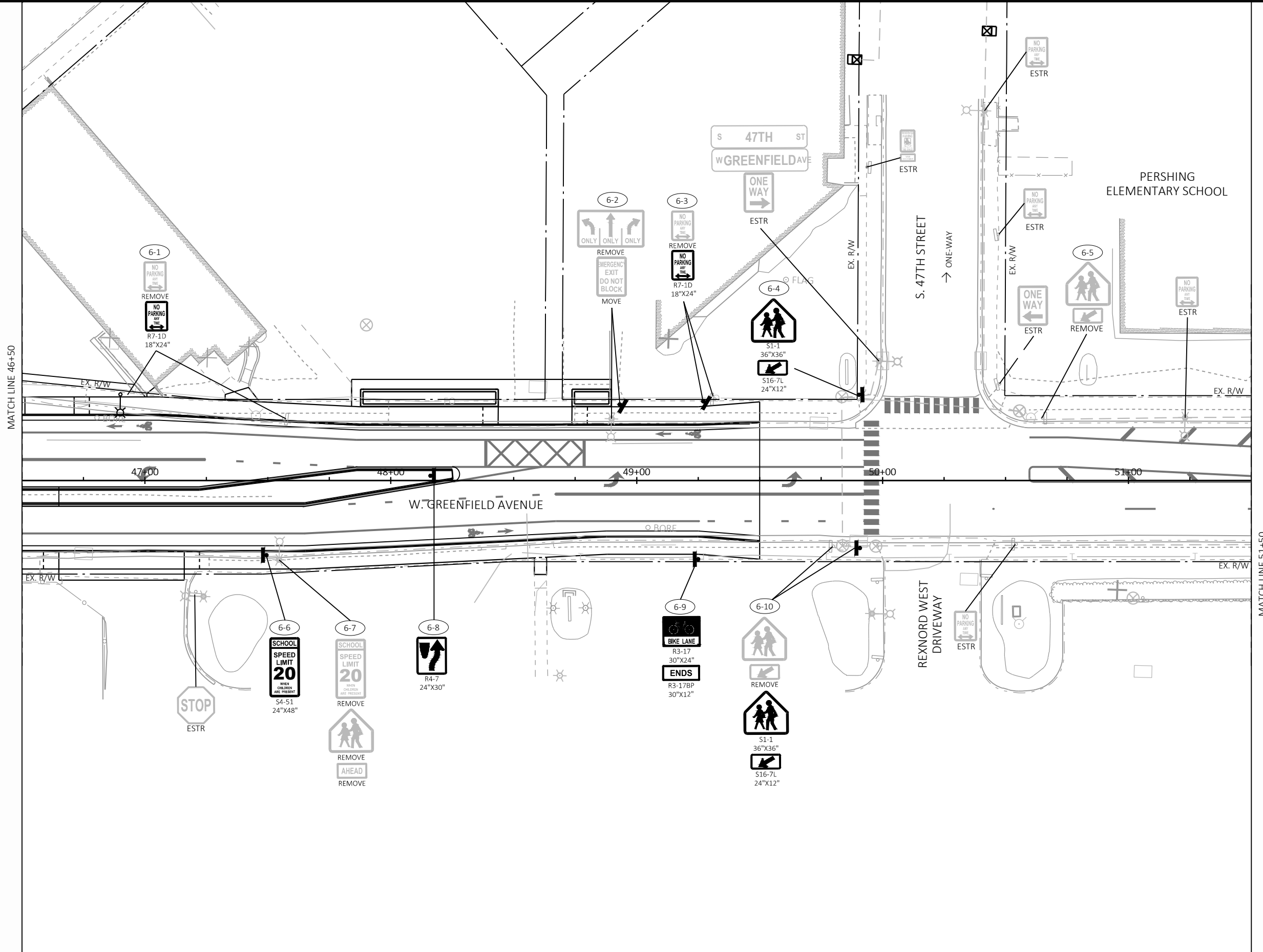

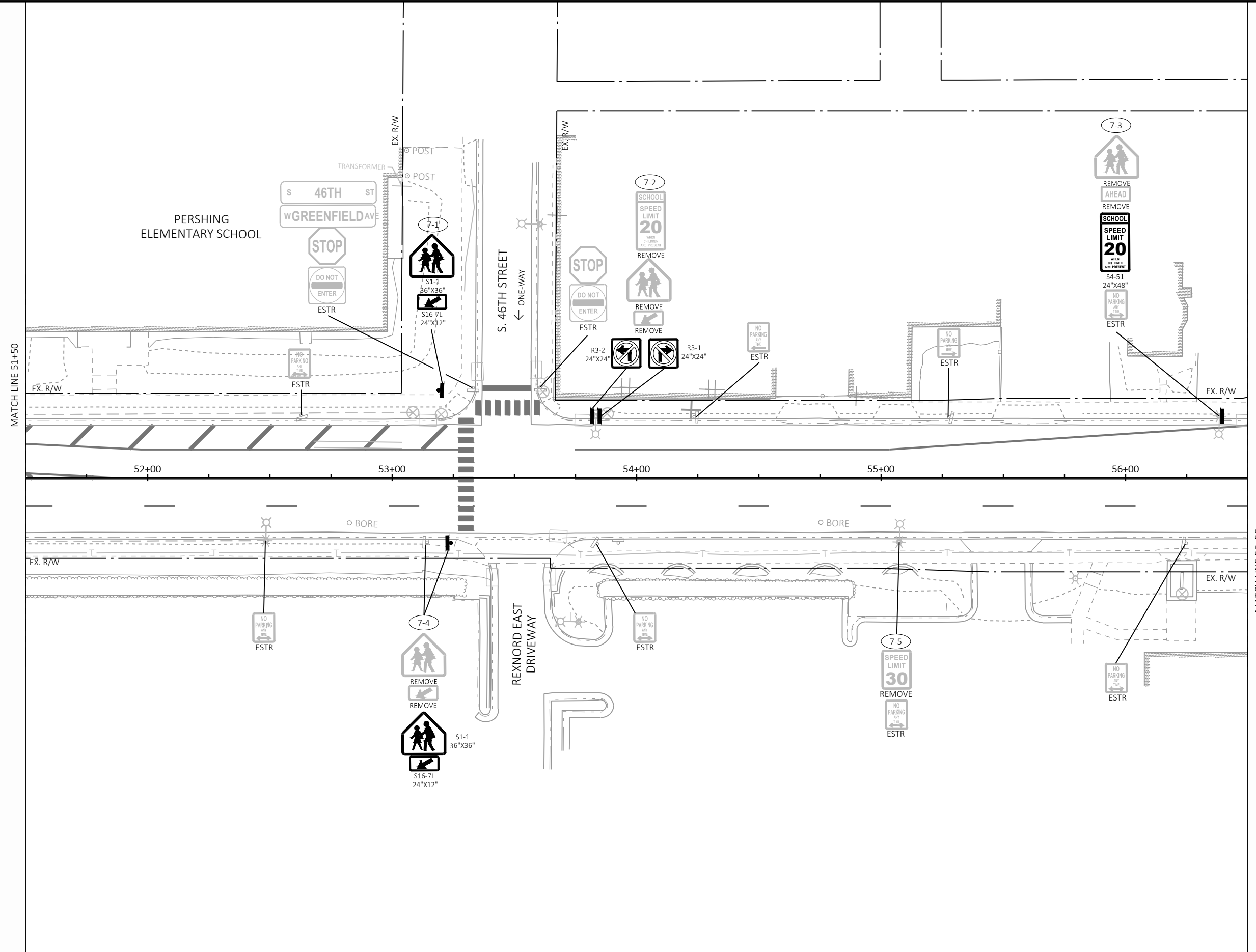

MATCH LINE 51+50

MATCH LINE 56+50

PROJECT NO: 2230-07-73	HWY: W. GREENFIELD AVENUE	COUNTY: MILWAUKEE	PERMANENT SIGNING	SHEET	E
------------------------	---------------------------	-------------------	-------------------	-------	----------

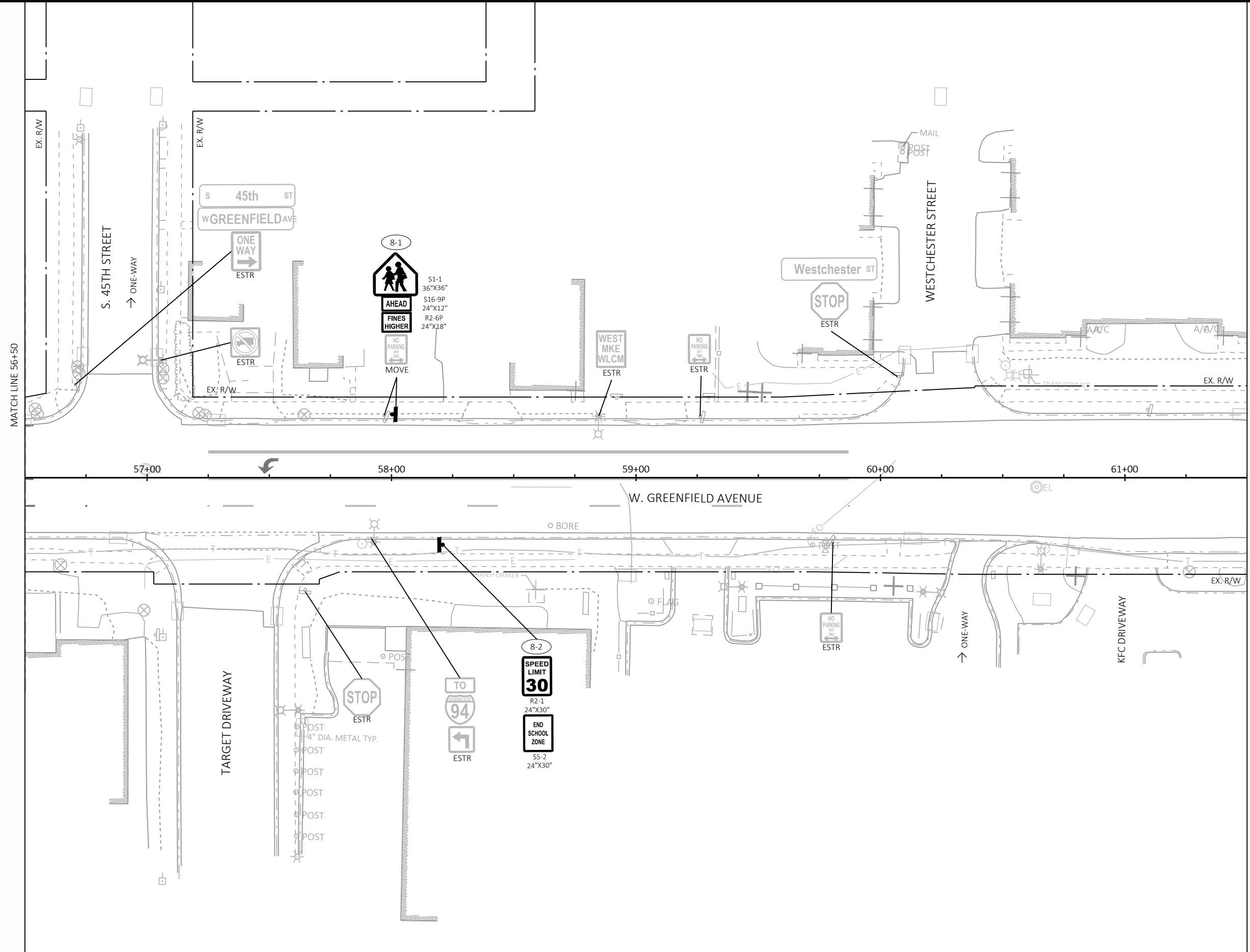

PROJECT NO: 2230-07-73

HWY: W. GREENFIELD AVENUE







COUNTY: MILWAUKEE

PERMANENT SIGNING

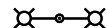
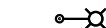
SHEET

E

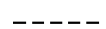
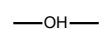
LIGHTING REMOVAL LEGEND

-  EXISTING LIGHT POLE - DUAL LUMINAIRE.
-  EXISTING LIGHT POLE - SINGLE LUMINAIRE.
-  EXISTING SHARED TRAFFIC SIGNAL & LIGHTING POLE. REFER TO TRAFFIC SIGNAL REMOVAL PLAN FOR ADDITIONAL INFORMATION.
-  TEMPORARY WOOD POLE FOR TEMPORARY OVERHEAD WIRING
-  EXISTING CONDUIT & CABLING TO BE REMOVED
-  TEMPORARY OVERHEAD LIGHTING CIRCUITS
-  LIGHTING CONTROL CABINET AND ELECTRICAL SERVICE METER BREAKER PEDESTAL ON CONCRETE CONTROL CABINET BASE
-  REMOVE PULL BOX

KEYED NOTES

- ① EXISTING LIGHT POLE TO REMAIN
- ② EXISTING LIGHT POLE TO BE REMOVED
- ③ EXISTING PULL BOX TO BE REMOVED
- ④ EXISTING INTERSECTION LIGHT FIXTURE. REFER TO TRAFFIC SIGNAL REMOVAL PLAN FOR ADDITIONAL INFORMATION.
- ⑤ EXISTING LIGHTING CONTROL CABINET TO REMAIN





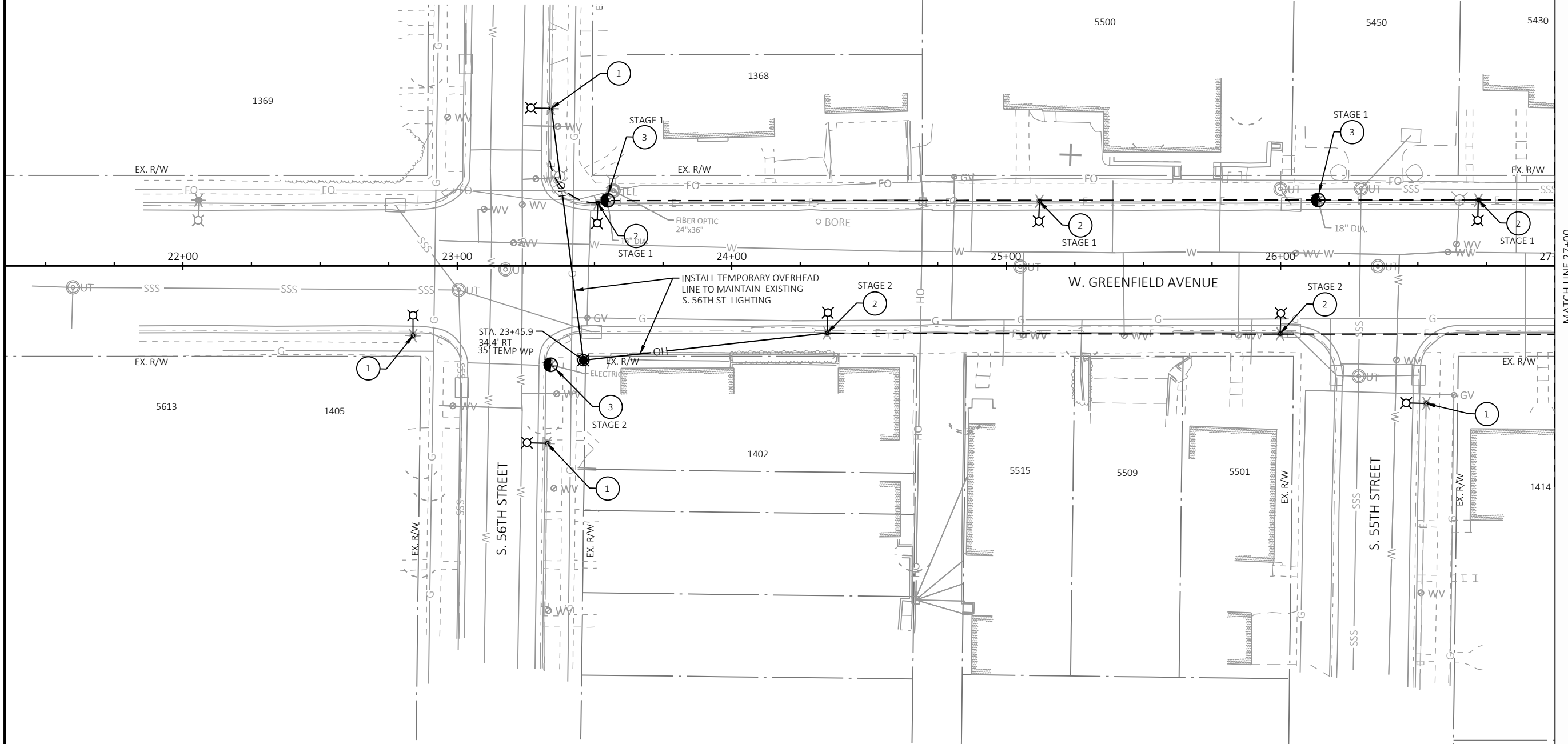

GENERAL NOTES:

- 1. ALL EXISTING CONDUIT WITHIN PROJECT LIMITS IS TO BE REMOVED.
- 2. MAINTAIN CONDUIT, CIRCUITRY AND EXISTING LIGHTING ON SOUTH SIDE OF GREENFIELD AVENUE DURING STAGE 1 FOR TEMPORARY LIGHTING.

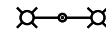
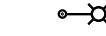
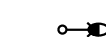

MATCH LINE 27+00

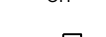
LIGHTING REMOVAL LEGEND

-  EXISTING LIGHT POLE - DUAL LUMINAIRE.
-  EXISTING LIGHT POLE - SINGLE LUMINAIRE.
-  EXISTING SHARED TRAFFIC SIGNAL & LIGHTING POLE. REFER TO TRAFFIC SIGNAL REMOVAL PLAN FOR ADDITIONAL INFORMATION.
-  TEMPORARY WOOD POLE FOR TEMPORARY OVERHEAD WIRING
-  EXISTING CONDUIT & CABLING TO BE REMOVED
-  TEMPORARY OVERHEAD LIGHTING CIRCUITS
-  LIGHTING CONTROL CABINET AND ELECTRICAL SERVICE METER BREAKER PEDESTAL ON CONCRETE CONTROL CABINET BASE
-  REMOVE PULL BOX

KEYED NOTES

- ① EXISTING LIGHT POLE TO REMAIN
- ② EXISTING LIGHT POLE TO BE REMOVED
- ③ EXISTING PULL BOX TO BE REMOVED
- ④ EXISTING INTERSECTION LIGHT FIXTURE. REFER TO TRAFFIC SIGNAL REMOVAL PLAN FOR ADDITIONAL INFORMATION.
- ⑤ EXISTING LIGHTING CONTROL CABINET TO REMAIN

GENERAL NOTES:

- 1. ALL EXISTING CONDUIT WITHIN PROJECT LIMITS IS TO BE REMOVED.
- 2. MAINTAIN CONDUIT, CIRCUITRY AND EXISTING LIGHTING ON SOUTH SIDE OF GREENFIELD AVENUE DURING STAGE 1 FOR TEMPORARY LIGHTING.

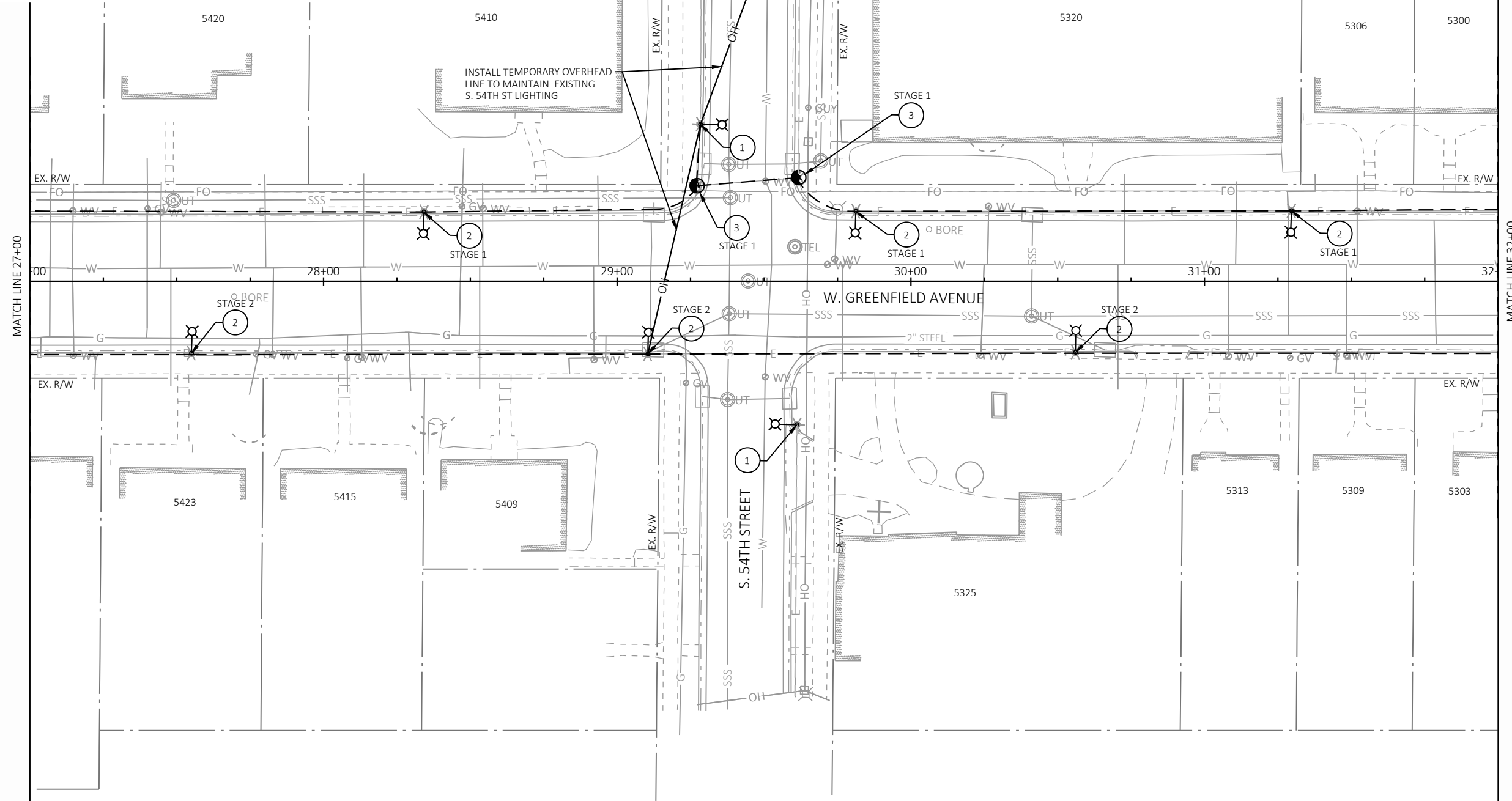

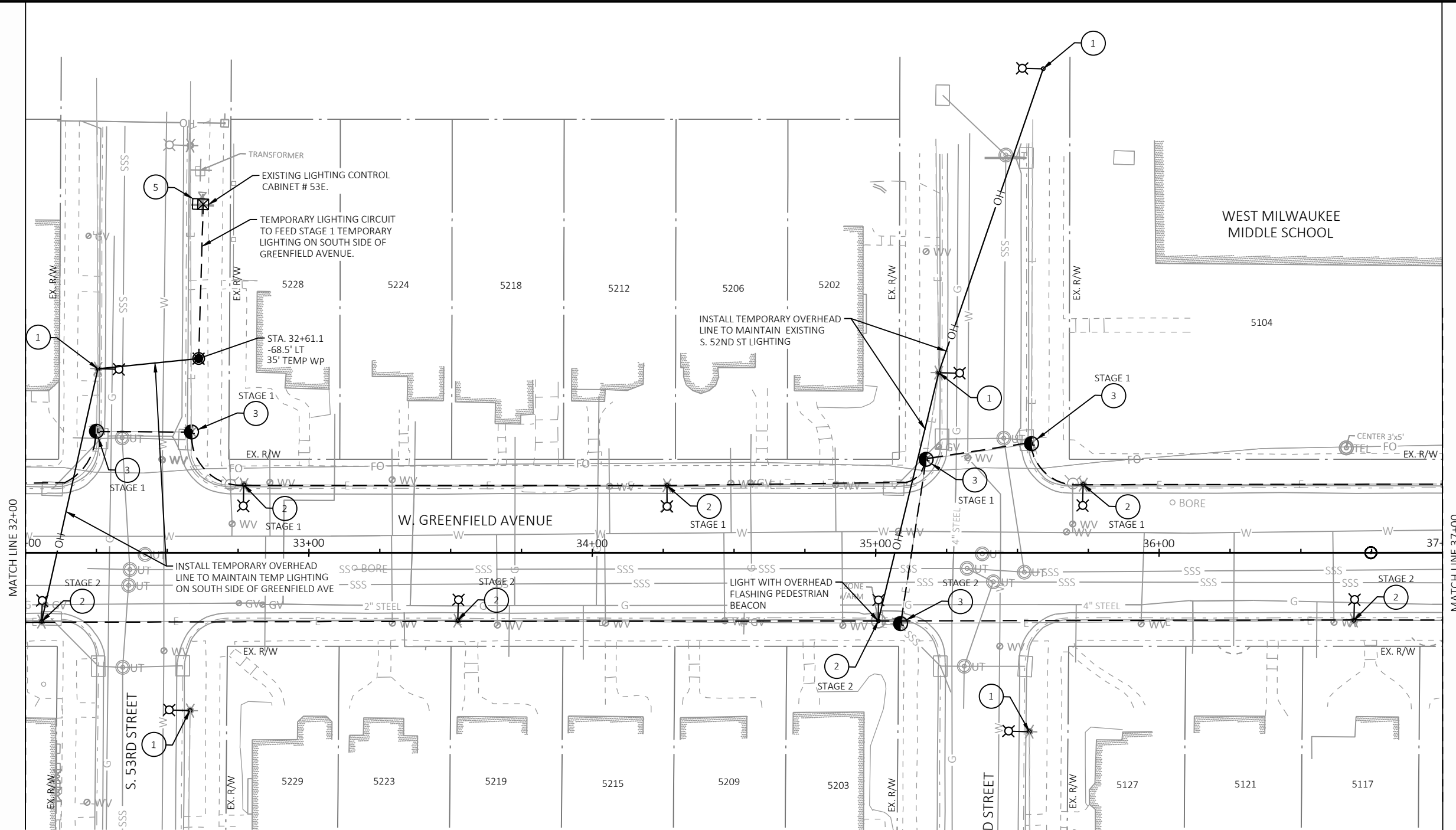

LIGHTING REMOVAL LEGEND

- EXISTING LIGHT POLE - DUAL LUMINAIRE.
- EXISTING LIGHT POLE - SINGLE LUMINAIRE.
- EXISTING SHARED TRAFFIC SIGNAL & LIGHTING POLE. REFER TO TRAFFIC SIGNAL REMOVAL PLAN FOR ADDITIONAL INFORMATION.
- TEMPORARY WOOD POLE FOR TEMPORARY OVERHEAD WIRING
- EXISTING CONDUIT & CABLING TO BE REMOVED
- TEMPORARY OVERHEAD LIGHTING CIRCUITS
- LIGHTING CONTROL CABINET AND ELECTRICAL SERVICE METER BREAKER PEDESTAL ON CONCRETE CONTROL CABINET BASE
- REMOVE PULL BOX









KEYED NOTES

- ① EXISTING LIGHT POLE TO REMAIN
- ② EXISTING LIGHT POLE TO BE REMOVED
- ③ EXISTING PULL BOX TO BE REMOVED
- ④ EXISTING INTERSECTION LIGHT FIXTURE. REFER TO TRAFFIC SIGNAL REMOVAL PLAN FOR ADDITIONAL INFORMATION.
- ⑤ EXISTING LIGHTING CONTROL CABINET TO REMAIN

GENERAL NOTES:

1. ALL EXISTING CONDUIT WITHIN PROJECT LIMITS IS TO BE REMOVED.
2. MAINTAIN CONDUIT, CIRCUITRY AND EXISTING LIGHTING ON SOUTH SIDE OF GREENFIELD AVENUE DURING STAGE 1 FOR TEMPORARY LIGHTING.

LIGHTING REMOVAL LEGEND

-  EXISTING LIGHT POLE - DUAL LUMINAIRE.
-  EXISTING LIGHT POLE - SINGLE LUMINAIRE.
-  EXISTING SHARED TRAFFIC SIGNAL & LIGHTING POLE. REFER TO TRAFFIC SIGNAL REMOVAL PLAN FOR ADDITIONAL INFORMATION.
-  TEMPORARY WOOD POLE FOR TEMPORARY OVERHEAD WIRING
-  EXISTING CONDUIT & CABLING TO BE REMOVED
-  TEMPORARY OVERHEAD LIGHTING CIRCUITS
-  LIGHTING CONTROL CABINET AND ELECTRICAL SERVICE METER BREAKER PEDESTAL ON CONCRETE CONTROL CABINET BASE
-  REMOVE PULL BOX

KEYED NOTES

- ① EXISTING LIGHT POLE TO REMAIN
- ② EXISTING LIGHT POLE TO BE REMOVED
- ③ EXISTING PULL BOX TO BE REMOVED
- ④ EXISTING INTERSECTION LIGHT FIXTURE. REFER TO TRAFFIC SIGNAL REMOVAL PLAN FOR ADDITIONAL INFORMATION.
- ⑤ EXISTING LIGHTING CONTROL CABINET TO REMAIN

GENERAL NOTES:

- 1. ALL EXISTING CONDUIT WITHIN PROJECT LIMITS IS TO BE REMOVED.
- 2. MAINTAIN CONDUIT, CIRCUITRY AND EXISTING LIGHTING ON SOUTH SIDE OF GREENFIELD AVENUE DURING STAGE 1 FOR TEMPORARY LIGHTING.

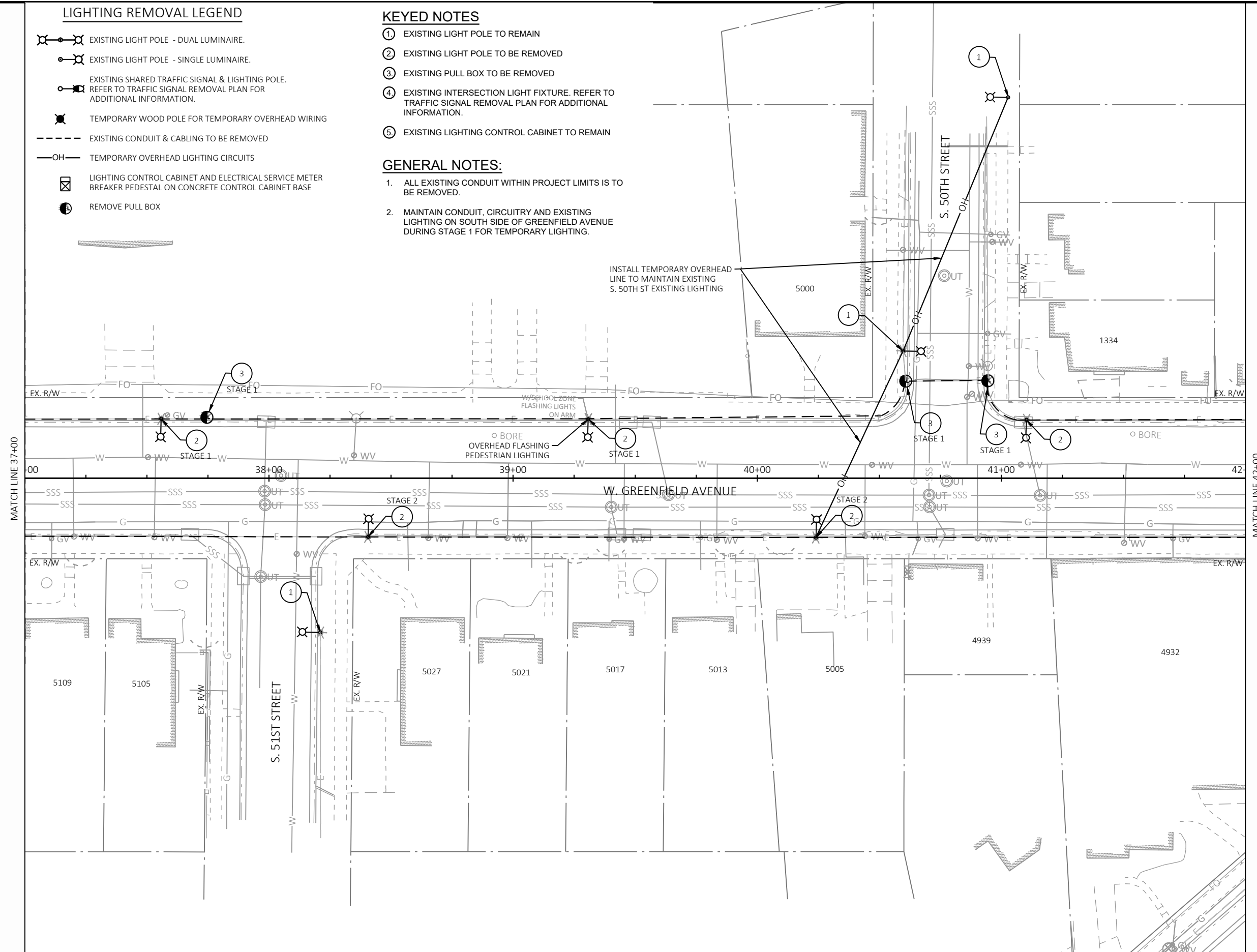

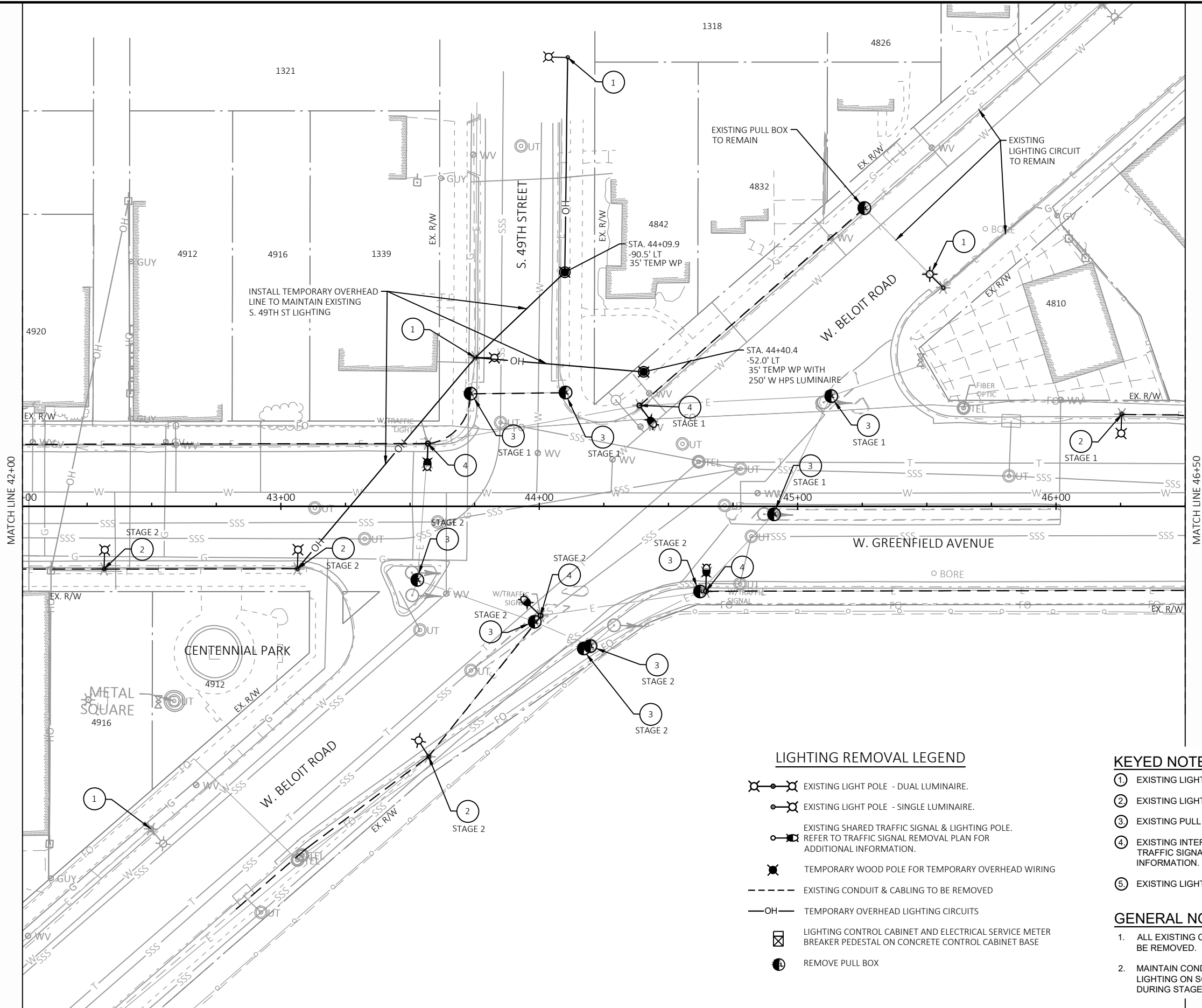

INSTALL TEMPORARY OVERHEAD LINE TO MAINTAIN EXISTING S. 49TH ST LIGHTING

EXISTING PULL BOX TO REMAIN

EXISTING LIGHTING CIRCUIT TO REMAIN

STA. 44+09.9
-90.5' LT
35' TEMP WP

STA. 44+40.4
-52.0' LT
35' TEMP WP WITH
250' W HPS LUMINAIRE

CENTENNIAL PARK

METAL SQUARE

LIGHTING REMOVAL LEGEND

- EXISTING LIGHT POLE - DUAL LUMINAIRE.
- EXISTING LIGHT POLE - SINGLE LUMINAIRE.
- EXISTING SHARED TRAFFIC SIGNAL & LIGHTING POLE. REFER TO TRAFFIC SIGNAL REMOVAL PLAN FOR ADDITIONAL INFORMATION.
- TEMPORARY WOOD POLE FOR TEMPORARY OVERHEAD WIRING
- EXISTING CONDUIT & CABLING TO BE REMOVED
- TEMPORARY OVERHEAD LIGHTING CIRCUITS
- LIGHTING CONTROL CABINET AND ELECTRICAL SERVICE METER BREAKER PEDESTAL ON CONCRETE CONTROL CABINET BASE
- REMOVE PULL BOX

KEYED NOTES

- ① EXISTING LIGHT POLE TO REMAIN
- ② EXISTING LIGHT POLE TO BE REMOVED
- ③ EXISTING PULL BOX TO BE REMOVED
- ④ EXISTING INTERSECTION LIGHT FIXTURE. REFER TO TRAFFIC SIGNAL REMOVAL PLAN FOR ADDITIONAL INFORMATION.
- ⑤ EXISTING LIGHTING CONTROL CABINET TO REMAIN

GENERAL NOTES:

- 1. ALL EXISTING CONDUIT WITHIN PROJECT LIMITS IS TO BE REMOVED.
- 2. MAINTAIN CONDUIT, CIRCUITRY AND EXISTING LIGHTING ON SOUTH SIDE OF GREENFIELD AVENUE DURING STAGE 1 FOR TEMPORARY LIGHTING.

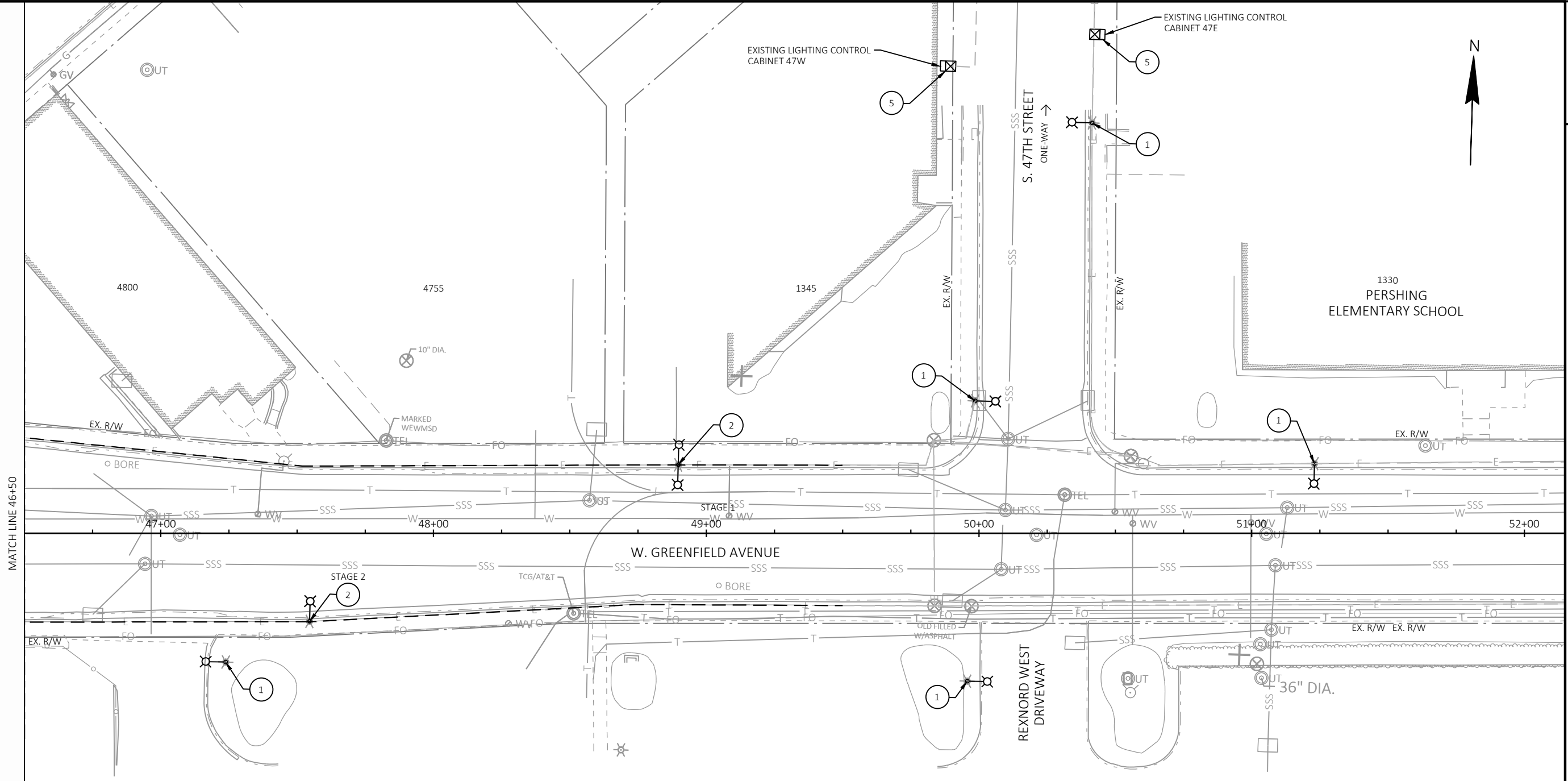

LIGHTING REMOVAL LEGEND

- EXISTING LIGHT POLE - DUAL LUMINAIRE.
- EXISTING LIGHT POLE - SINGLE LUMINAIRE.
- EXISTING SHARED TRAFFIC SIGNAL & LIGHTING POLE. REFER TO TRAFFIC SIGNAL REMOVAL PLAN FOR ADDITIONAL INFORMATION.
- TEMPORARY WOOD POLE FOR TEMPORARY OVERHEAD WIRING
- EXISTING CONDUIT & CABLING TO BE REMOVED
- TEMPORARY OVERHEAD LIGHTING CIRCUITS
- LIGHTING CONTROL CABINET AND ELECTRICAL SERVICE METER BREAKER PEDESTAL ON CONCRETE CONTROL CABINET BASE
- REMOVE PULL BOX

KEYED NOTES

- ① EXISTING LIGHT POLE TO REMAIN
- ② EXISTING LIGHT POLE TO BE REMOVED
- ③ EXISTING PULL BOX TO BE REMOVED
- ④ EXISTING INTERSECTION LIGHT FIXTURE. REFER TO TRAFFIC SIGNAL REMOVAL PLAN FOR ADDITIONAL INFORMATION.
- ⑤ EXISTING LIGHTING CONTROL CABINET TO REMAIN

GENERAL NOTES:

1. ALL EXISTING CONDUIT WITHIN PROJECT LIMITS IS TO BE REMOVED.
2. MAINTAIN CONDUIT, CIRCUITRY AND EXISTING LIGHTING ON SOUTH SIDE OF GREENFIELD AVENUE DURING STAGE 1 FOR TEMPORARY LIGHTING.

8 7 6 5 4 3 2 1

H
G
F
E

H
G
F
E

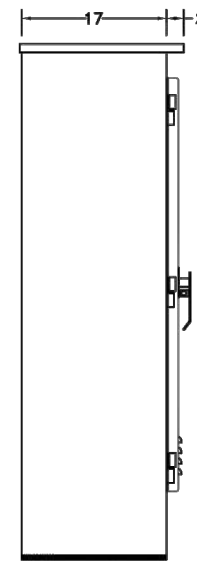

SIDE VIEW

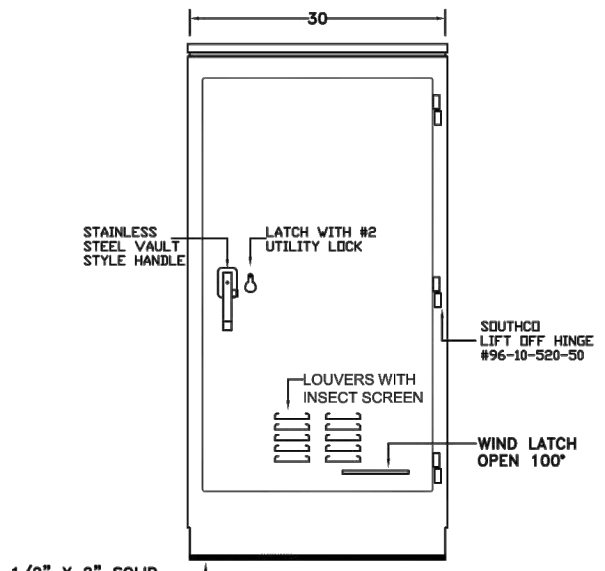

FRONT VIEW

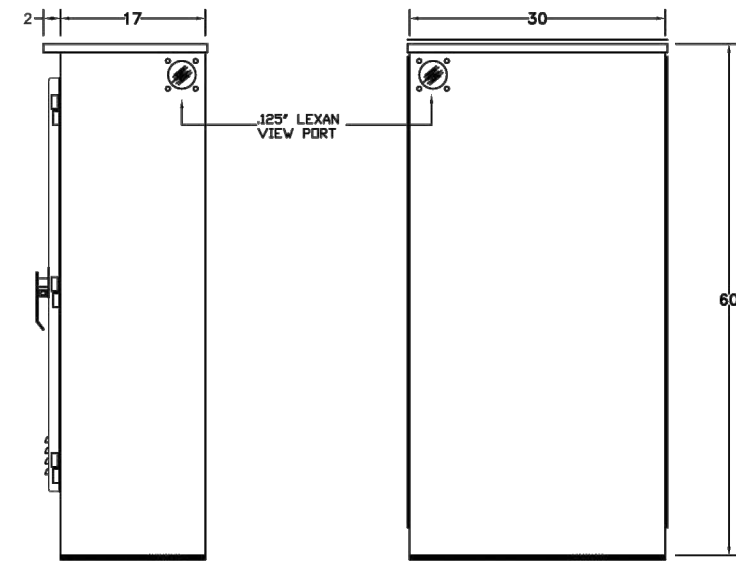

REAR VIEW

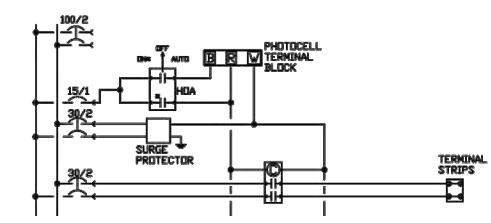
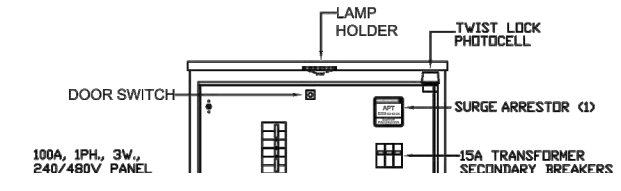

CONSTRUCTION NOTES:

- CABINET TO BE TYPE 3R CONSTRUCTION PER UL 50 REQUIREMENTS.
- CABINET TO BE FABRICATED FROM FORMED AND WELDED .125" ALUMINUM.
- CABINET TO BE SILVER WITH WHITE INTERIOR POWDER COAT PAINT
- ALL CABINET EXTERIOR HARDWARE TO BE STAINLESS STEEL.
- EXTERIOR DOOR HELD CLOSED WITH A VAULT TYPE HANDLE AND #2 UTILITY LOCK.
- EXTERIOR DOOR SHALL BE SEALED WITH CLOSED CELL 3/16" X 1" NEOPRENE GASKETING
- EXTERIOR DOOR SHALL HAVE A WIND LATCH HINGED INNER DEAD FRONT TO BE HELD CAPTIVE WITH 1/4 TURN LATCHES.
- 8" X 10" PRINT POCKET ON REAR OF OUTER DOOR.
- THE COMPLETED ASSEMBLY TO BE UL508A LISTED. 22K AIC SHORT CIRCUIT RATING.

BILL OF MATERIAL:

- 100A, 1PH, 3W, 240/480V, 22K AIC PANEL WITH COPPER BUS BAR BY STATES MFG.
- 1 - 100A 2P MAIN BREAKER SIEMENS #ED62B100
- 2 - 15A 1P BRANCH BREAKER SIEMENS #ED41B015
- 7 - 30A 2P BRANCH BREAKER SIEMENS #ED42B030
- SURGE PROTECTOR, (S) 50KA SURGE CURRENT CAPACITY, 240/480V SPLIT PHASE ADVANCE PROTECTION TECH. #550A277V2PN
- HAND-OFF-AUTO SELECTOR SWITCH ALLEN BRADLEY #800T-J2A
- PHOTOCELL AREA LIGHTING RESEARCH SST-PU-IES-UL

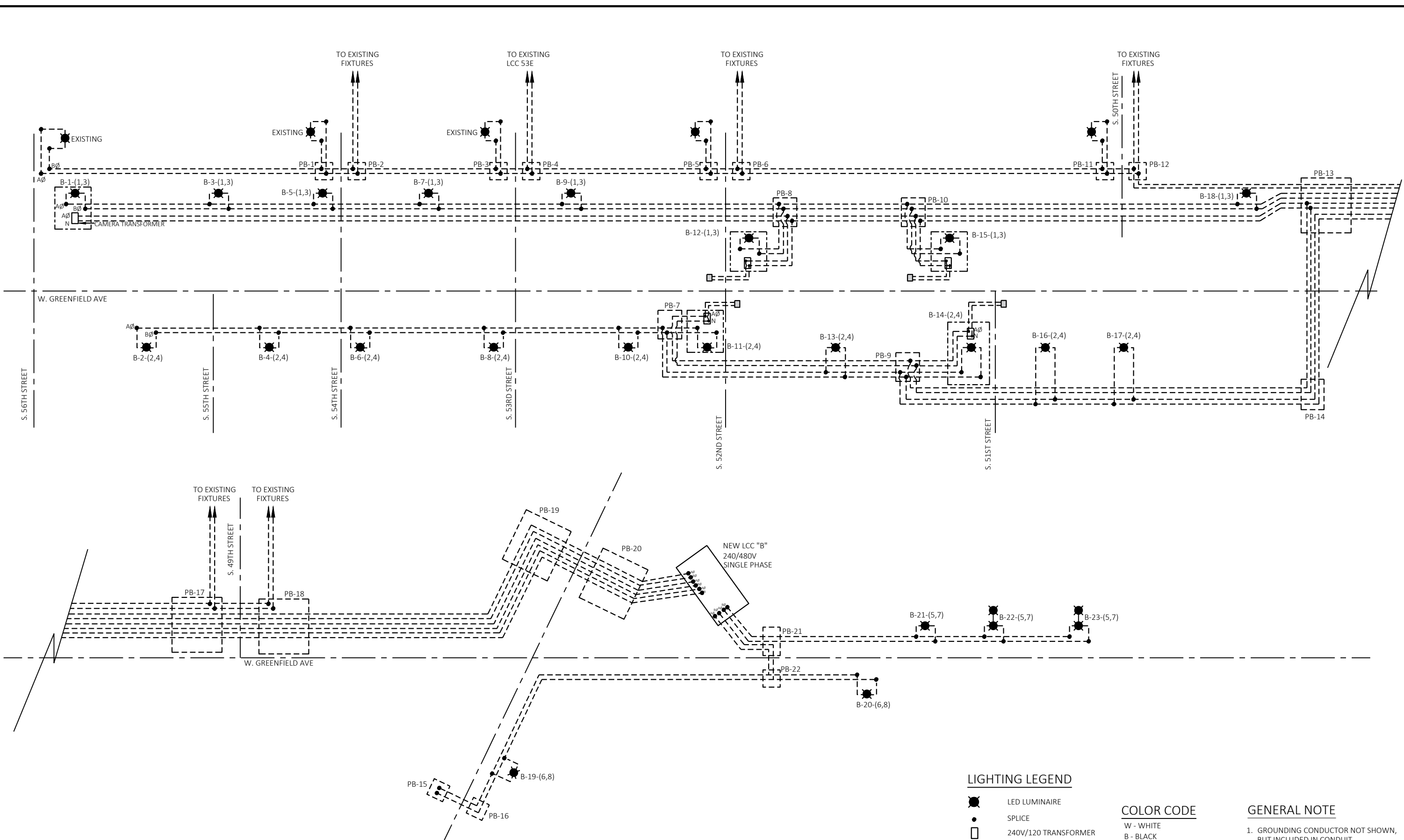

WIRING DIAGRAM - CABINET "B" (240/480V)
NTS

LIGHTING LEGEND

- LED LUMINAIRE
- SPLICE
- 240V/120 TRANSFORMER
- RAPID FLASHING BEACON

COLOR CODE

- W - WHITE
- B - BLACK

GENERAL NOTE

1. GROUNDING CONDUCTOR NOT SHOWN, BUT INCLUDED IN CONDUIT.

LIGHTING LEGEND

- CONTROL CABINET DESIGNATION
- POLE NUMBER
- LIGHTING CIRCUIT(S)
- LOCATION (TO CENTER OF POLE)
- LUMINAIRE ARM LENGTH IN FEET
- POLE TYPE (T) INCLUDES TRANSFORMER BASE
- LUMINAIRE DESIGNATION LIGHT POLE & LUMINAIRE SPECIAL
- LIGHTING CONTROL CABINET AND ELECTRICAL SERVICE METER BREAKER PEDESTAL ON CONCRETE CONTROL CABINET BASE
- PULL BOX, 24"x36"

- ETR EXISTING LIGHT FIXTURE - DUAL LUMINAIRE.
- ETR EXISTING LIGHT FIXTURE - SINGLE LUMINAIRE.
- PROPOSED LIGHT FIXTURE - DUAL LUMINAIRE.
- PROPOSED LIGHT FIXTURE - SINGLE LUMINAIRE.
- ETR EXISTING INTERSECTION LIGHTING FIXTURE - SINGLE LUMINAIRE.
- PROPOSED INTERSECTION LIGHTING FIXTURE - SINGLE LUMINAIRE. (SEE TRAFFIC SIGNAL PLANS - SHOWN FOR INFORMATION ONLY)
- PROPOSED CONDUIT (SEE CABLE AND CONDUIT LEGEND)
- EXISTING CONDUIT TO REMAIN

CABLE AND CONDUIT LEGEND

- A 6 - #6 AWG AND 1 - #6 GROUND IN 2" RIGID NONMETALLIC CONDUIT.
- B 4 - #6 AWG AND 1 - #6 GROUND IN 2" RIGID NONMETALLIC CONDUIT.
- C 2 - #6 AWG AND 1 - #6 GROUND IN 2" RIGID NONMETALLIC CONDUIT.
- D EMPTY 2" RIGID NONMETALLIC CONDUIT WITH PULL (CONDUCTORS ARE FUTURE).

KEYED NOTES

- ① EXISTING LIGHT POLE TO REMAIN

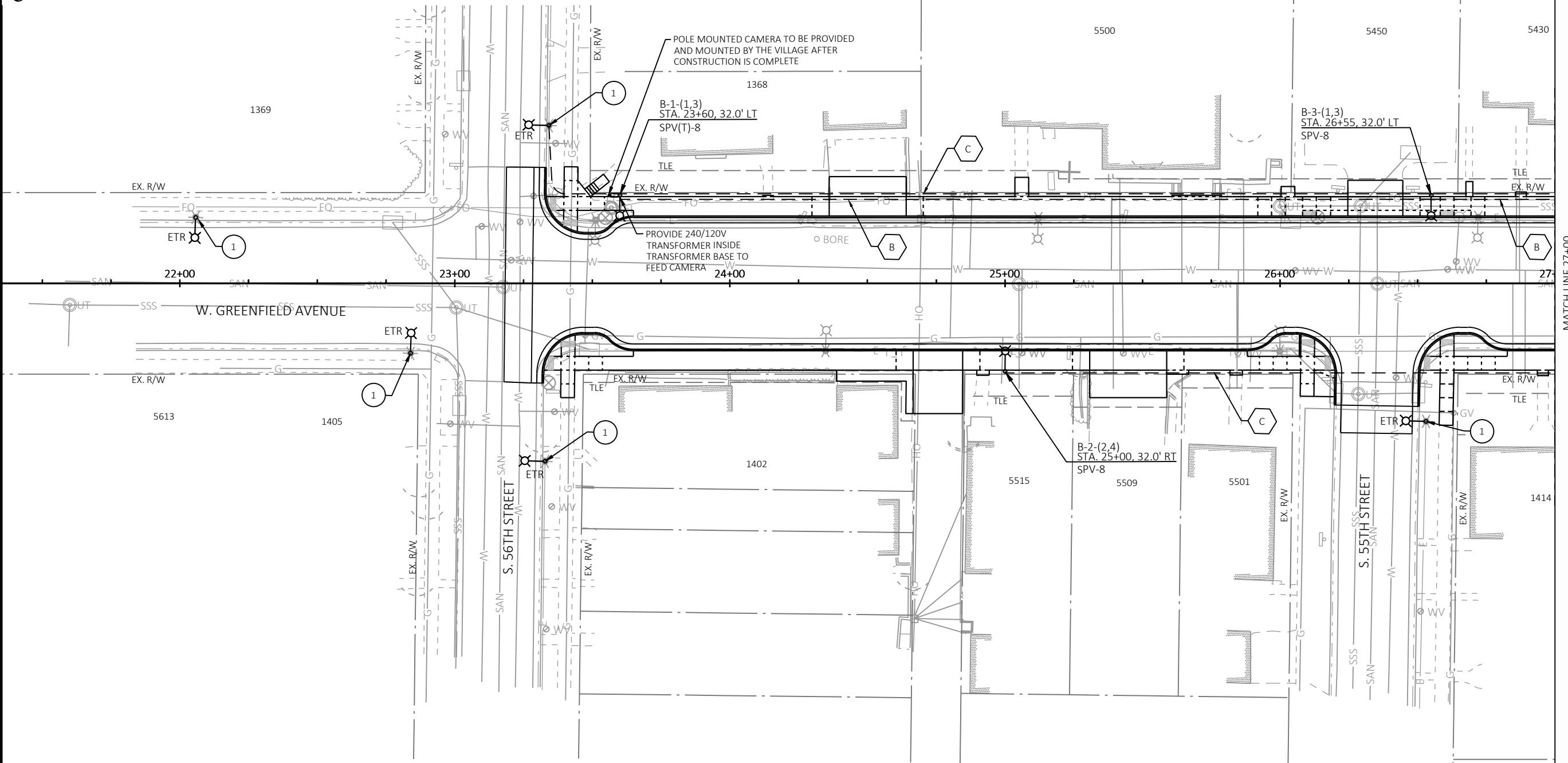

CABLE AND CONDUIT LEGEND

- A 6 - #6 AWG AND 1 - #6 GROUND IN 2" RIGID NONMETALLIC CONDUIT.
- B 4 - #6 AWG AND 1 - #6 GROUND IN 2" RIGID NONMETALLIC CONDUIT.
- C 2 - #6 AWG AND 1 - #6 GROUND IN 2" RIGID NONMETALLIC CONDUIT.
- D EMPTY 2" RIGID NONMETALLIC CONDUIT WITH PULL (CONDUCTORS ARE FUTURE).

KEYED NOTES

- ① EXISTING LIGHT POLE TO REMAIN

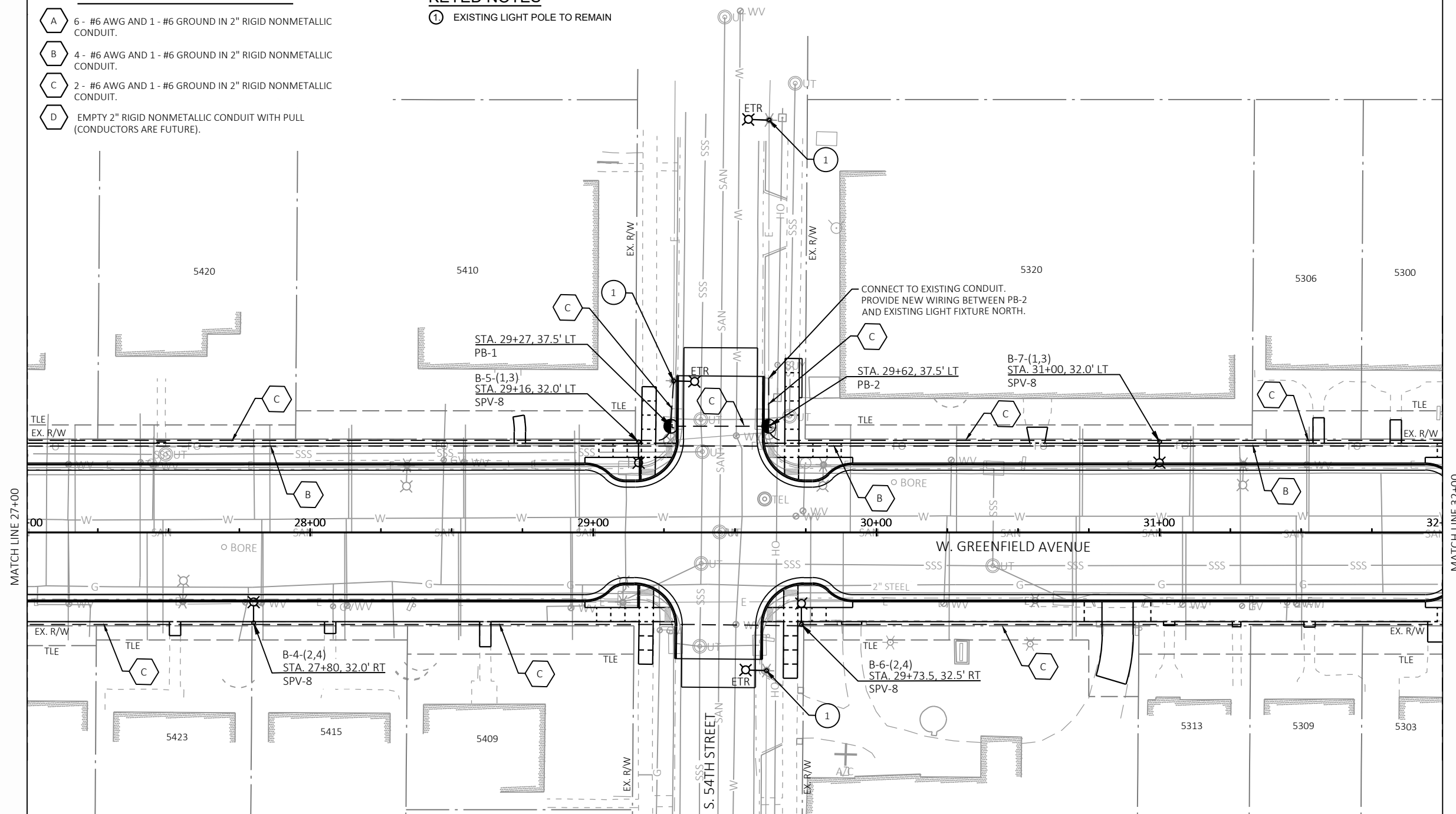

LIGHTING LEGEND

- CONTROL CABINET DESIGNATION
- POLE NUMBER
- LIGHTING CIRCUIT(S)
- LOCATION (TO CENTER OF POLE)
- LUMINAIRE ARM LENGTH IN FEET
- POLE TYPE (T) INCLUDES TRANSFORMER BASE
- LUMINAIRE DESIGNATION LIGHT POLE & LUMINAIRE SPECIAL
- LIGHTING CONTROL CABINET AND ELECTRICAL SERVICE METER BREAKER PEDESTAL ON CONCRETE CONTROL CABINET BASE
- PULL BOX, 24"x36"
- ETR EXISTING LIGHT FIXTURE - DUAL LUMINAIRE.
- ETR EXISTING LIGHT FIXTURE - SINGLE LUMINAIRE.
- PROPOSED LIGHT FIXTURE - DUAL LUMINAIRE.
- PROPOSED LIGHT FIXTURE - SINGLE LUMINAIRE.
- ETR EXISTING INTERSECTION LIGHTING FIXTURE - SINGLE LUMINAIRE.
- PROPOSED INTERSECTION LIGHTING FIXTURE - SINGLE LUMINAIRE. (SEE TRAFFIC SIGNAL PLANS - SHOWN FOR INFORMATION ONLY)
- PROPOSED CONDUIT (SEE CABLE AND CONDUIT LEGEND)
- EXISTING CONDUIT TO REMAIN

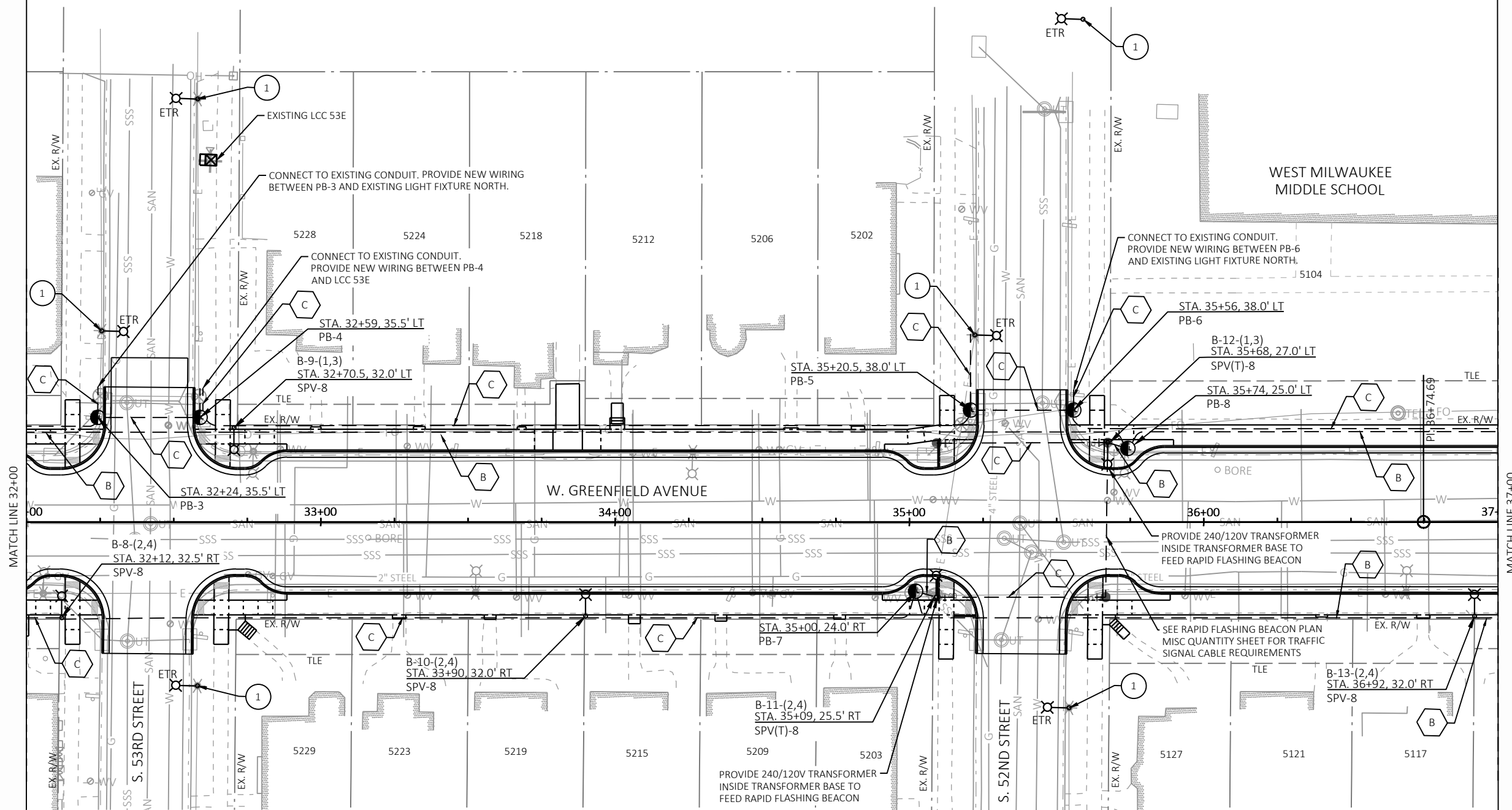

MATCH LINE 32+00

MATCH LINE 37+00

LIGHTING LEGEND

- CONTROL CABINET DESIGNATION
- POLE NUMBER
- LIGHTING CIRCUIT(S)
- LOCATION (TO CENTER OF POLE)
- LUMINAIRE ARM LENGTH IN FEET
- POLE TYPE
(T) INCLUDES TRANSFORMER BASE
- LUMINAIRE DESIGNATION
LIGHT POLE & LUMINAIRE SPECIAL
- LIGHTING CONTROL CABINET AND ELECTRICAL SERVICE METER
BREAKER PEDESTAL ON CONCRETE CONTROL CABINET BASE
- PULL BOX, 24"x36"
- EXISTING LIGHT FIXTURE - DUAL LUMINAIRE.
- EXISTING LIGHT FIXTURE - SINGLE LUMINAIRE.
- PROPOSED LIGHT FIXTURE - DUAL LUMINAIRE.
- PROPOSED LIGHT FIXTURE - SINGLE LUMINAIRE.
- EXISTING INTERSECTION LIGHTING FIXTURE - SINGLE LUMINAIRE.
- PROPOSED INTERSECTION LIGHTING FIXTURE - SINGLE LUMINAIRE.
(SEE TRAFFIC SIGNAL PLANS - SHOWN FOR INFORMATION ONLY)
- PROPOSED CONDUIT (SEE CABLE AND CONDUIT LEGEND)
- EXISTING CONDUIT TO REMAIN

CABLE AND CONDUIT LEGEND

- A 6 - #6 AWG AND 1 - #6 GROUND IN 2" RIGID NONMETALLIC CONDUIT.
- B 4 - #6 AWG AND 1 - #6 GROUND IN 2" RIGID NONMETALLIC CONDUIT.
- C 2 - #6 AWG AND 1 - #6 GROUND IN 2" RIGID NONMETALLIC CONDUIT.
- D EMPTY 2" RIGID NONMETALLIC CONDUIT WITH PULL
(CONDUCTORS ARE FUTURE).

KEYED NOTES

- ① EXISTING LIGHT POLE TO REMAIN

LIGHTING LEGEND

- CONTROL CABINET DESIGNATION
- POLE NUMBER
- LIGHTING CIRCUIT(S)
- LOCATION (TO CENTER OF POLE)
- LUMINAIRE ARM LENGTH IN FEET
- POLE TYPE
(T) INCLUDES TRANSFORMER BASE
- LUMINAIRE DESIGNATION
LIGHT POLE & LUMINAIRE SPECIAL
- LIGHTING CONTROL CABINET AND ELECTRICAL SERVICE METER
BREAKER PEDESTAL ON CONCRETE CONTROL CABINET BASE
- PULL BOX, 24"x36"
- EXISTING LIGHT FIXTURE - DUAL LUMINAIRE.
- EXISTING LIGHT FIXTURE - SINGLE LUMINAIRE.
- PROPOSED LIGHT FIXTURE - DUAL LUMINAIRE.
- PROPOSED LIGHT FIXTURE - SINGLE LUMINAIRE.
- EXISTING INTERSECTION LIGHTING FIXTURE - SINGLE LUMINAIRE.
- PROPOSED INTERSECTION LIGHTING FIXTURE - SINGLE LUMINAIRE.
(SEE TRAFFIC SIGNAL PLANS - SHOWN FOR INFORMATION ONLY)
- PROPOSED CONDUIT (SEE CABLE AND CONDUIT LEGEND)
- EXISTING CONDUIT TO REMAIN

KEYED NOTES

- ① EXISTING LIGHT POLE TO REMAIN

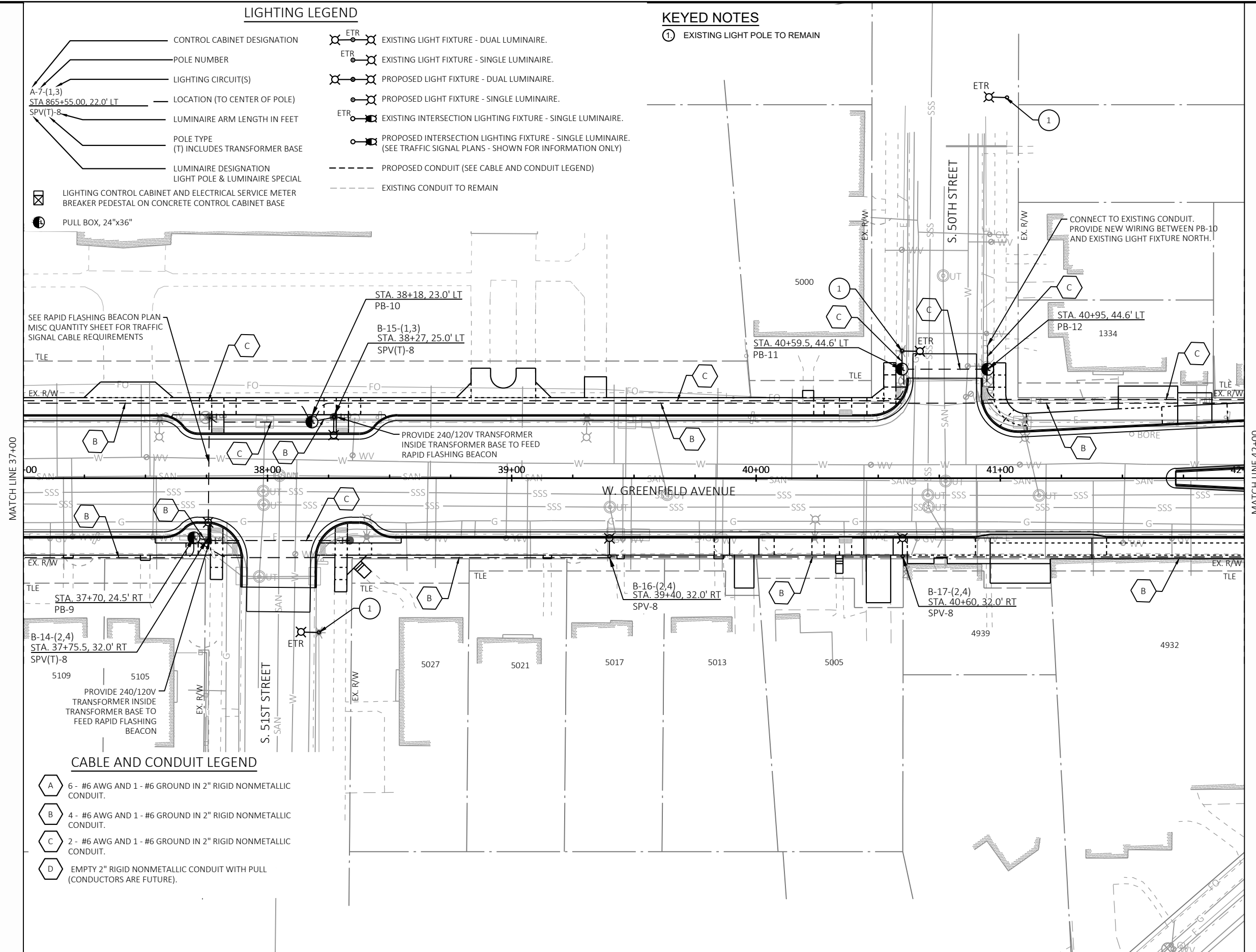

CABLE AND CONDUIT LEGEND

- A 6 - #6 AWG AND 1 - #6 GROUND IN 2" RIGID NONMETALLIC CONDUIT.
- B 4 - #6 AWG AND 1 - #6 GROUND IN 2" RIGID NONMETALLIC CONDUIT.
- C 2 - #6 AWG AND 1 - #6 GROUND IN 2" RIGID NONMETALLIC CONDUIT.
- D EMPTY 2" RIGID NONMETALLIC CONDUIT WITH PULL (CONDUCTORS ARE FUTURE).

CABLE AND CONDUIT LEGEND

- A 6 - #6 AWG AND 1 - #6 GROUND IN 2" RIGID NONMETALLIC CONDUIT.
- B 4 - #6 AWG AND 1 - #6 GROUND IN 2" RIGID NONMETALLIC CONDUIT.
- C 2 - #6 AWG AND 1 - #6 GROUND IN 2" RIGID NONMETALLIC CONDUIT.
- D EMPTY 2" RIGID NONMETALLIC CONDUIT WITH PULL (CONDUCTORS ARE FUTURE).

KEYED NOTES

- ① EXISTING LIGHT POLE TO REMAIN

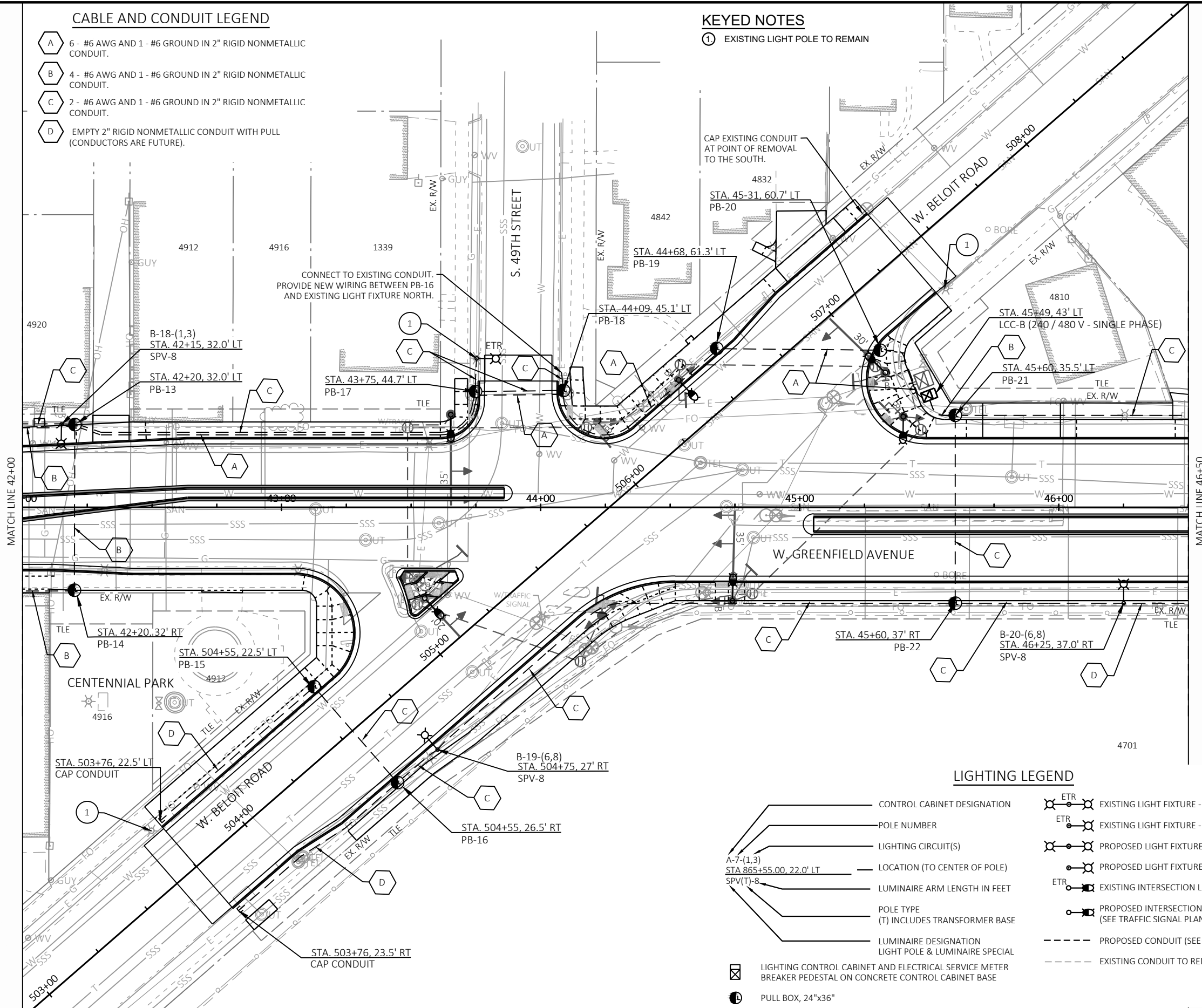

LIGHTING LEGEND

- CONTROL CABINET DESIGNATION
- POLE NUMBER
- LIGHTING CIRCUIT(S)
- LOCATION (TO CENTER OF POLE)
- LUMINAIRE ARM LENGTH IN FEET
- POLE TYPE (T) INCLUDES TRANSFORMER BASE
- LUMINAIRE DESIGNATION LIGHT POLE & LUMINAIRE SPECIAL
- LIGHTING CONTROL CABINET AND ELECTRICAL SERVICE METER BREAKER PEDESTAL ON CONCRETE CONTROL CABINET BASE
- PULL BOX, 24"x36"
- ETR EXISTING LIGHT FIXTURE - DUAL LUMINAIRE.
- ETR EXISTING LIGHT FIXTURE - SINGLE LUMINAIRE.
- PROPOSED LIGHT FIXTURE - DUAL LUMINAIRE.
- PROPOSED LIGHT FIXTURE - SINGLE LUMINAIRE.
- ETR EXISTING INTERSECTION LIGHTING FIXTURE - SINGLE LUMINAIRE.
- PROPOSED INTERSECTION LIGHTING FIXTURE - SINGLE LUMINAIRE. (SEE TRAFFIC SIGNAL PLANS - SHOWN FOR INFORMATION ONLY)
- PROPOSED CONDUIT (SEE CABLE AND CONDUIT LEGEND)
- EXISTING CONDUIT TO REMAIN

CABLE AND CONDUIT LEGEND

- A 6 - #6 AWG AND 1 - #6 GROUND IN 2" RIGID NONMETALLIC CONDUIT.
- B 4 - #6 AWG AND 1 - #6 GROUND IN 2" RIGID NONMETALLIC CONDUIT.
- C 2 - #6 AWG AND 1 - #6 GROUND IN 2" RIGID NONMETALLIC CONDUIT.
- D EMPTY 2" RIGID NONMETALLIC CONDUIT WITH PULL (CONDUCTORS ARE FUTURE).

MATCH LINE 46+50

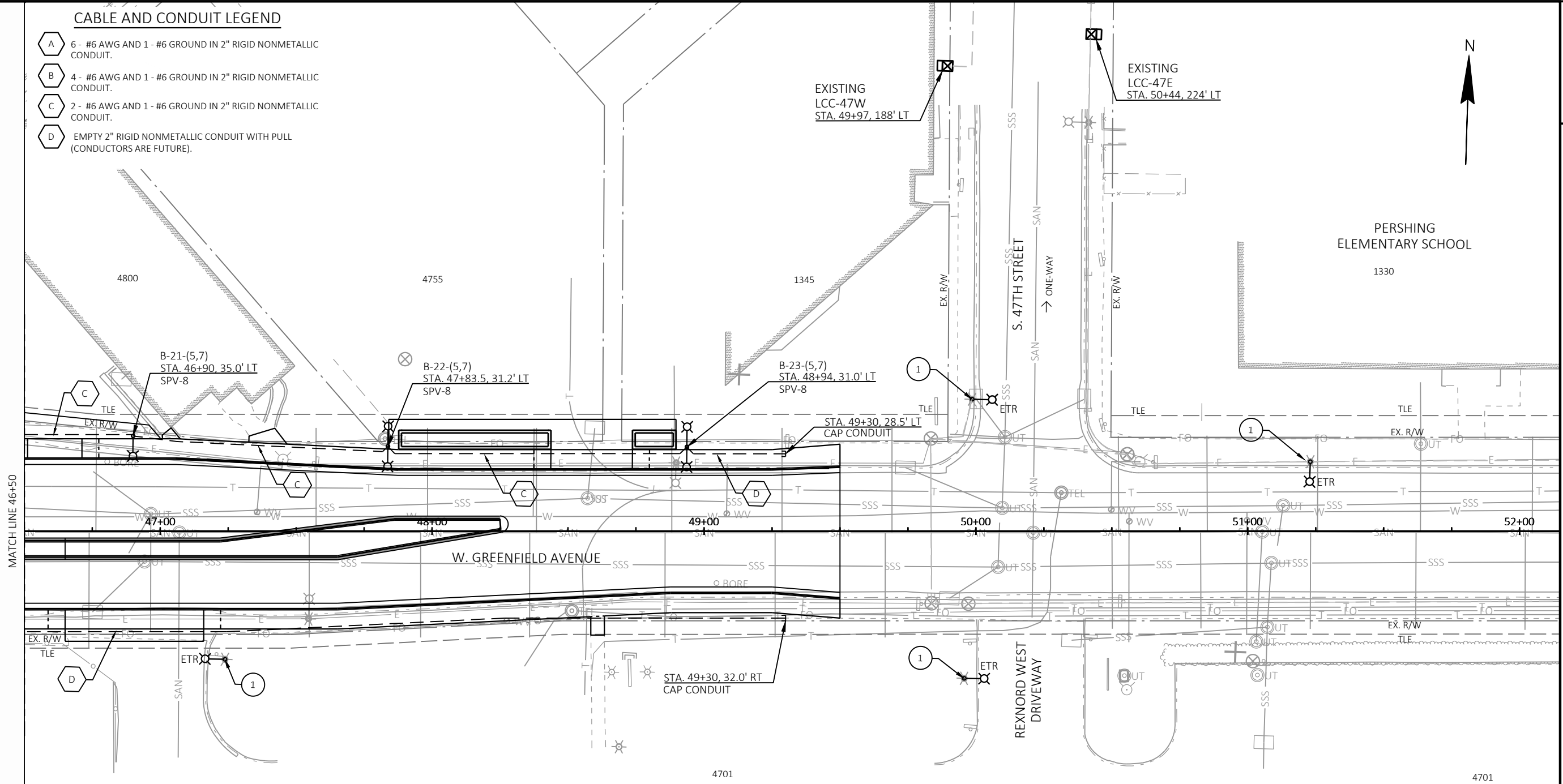

EXISTING LCC-47E STA. 50+44, 224' LT

EXISTING LCC-47W STA. 49+97, 188' LT

PERSHING ELEMENTARY SCHOOL

















LIGHTING LEGEND

- CONTROL CABINET DESIGNATION
- POLE NUMBER
- LIGHTING CIRCUIT(S)
- LOCATION (TO CENTER OF POLE)
- LUMINAIRE ARM LENGTH IN FEET
- POLE TYPE (T) INCLUDES TRANSFORMER BASE
- LUMINAIRE DESIGNATION LIGHT POLE & LUMINAIRE SPECIAL
- LIGHTING CONTROL CABINET AND ELECTRICAL SERVICE METER BREAKER PEDESTAL ON CONCRETE CONTROL CABINET BASE
- PULL BOX, 24"x36"
- ETR EXISTING LIGHT FIXTURE - DUAL LUMINAIRE.
- ETR EXISTING LIGHT FIXTURE - SINGLE LUMINAIRE.
- PROPOSED LIGHT FIXTURE - DUAL LUMINAIRE.
- PROPOSED LIGHT FIXTURE - SINGLE LUMINAIRE.
- ETR EXISTING INTERSECTION LIGHTING FIXTURE - SINGLE LUMINAIRE.
- PROPOSED INTERSECTION LIGHTING FIXTURE - SINGLE LUMINAIRE. (SEE TRAFFIC SIGNAL PLANS - SHOWN FOR INFORMATION ONLY)
- PROPOSED CONDUIT (SEE CABLE AND CONDUIT LEGEND)
- EXISTING CONDUIT TO REMAIN

KEYED NOTES

- ① EXISTING LIGHT POLE TO REMAIN

LEGEND

-  CONTROL CABINET
-  NONMETALLIC CONDUIT 2", UNLESS OTHERWISE NOTED
-  SIGNAL HEAD, TRAFFIC SIGNAL STANDARD, PEDESTAL BASE
-  PEDESTRIAN HEAD
-  LUMINAIRE, TRAFFIC POLE, TRANSFORMER BASE
-  MUNICIPAL LUMINAIRE, TRANSFORMER BASE
-  PULL BOX
-  SIGNAL HEAD NUMBER
-  RED CIRCULAR INDICATOR
-  YELLOW CIRCULAR INDICATOR
-  GREEN CIRCULAR INDICATOR
-  YELLOW ARROW
-  GREEN ARROW
-  DON'T WALK INDICATOR 16"
-  WALK INDICATOR 16"
-  STOP SIGN

- NOTES:
- ALL LENSES ARE 12-INCH
 - GRAYSHADE REPRESENTS EXISTING TO REMAIN
 - BOLD REPRESENTS EXISTING TO BE REMOVED

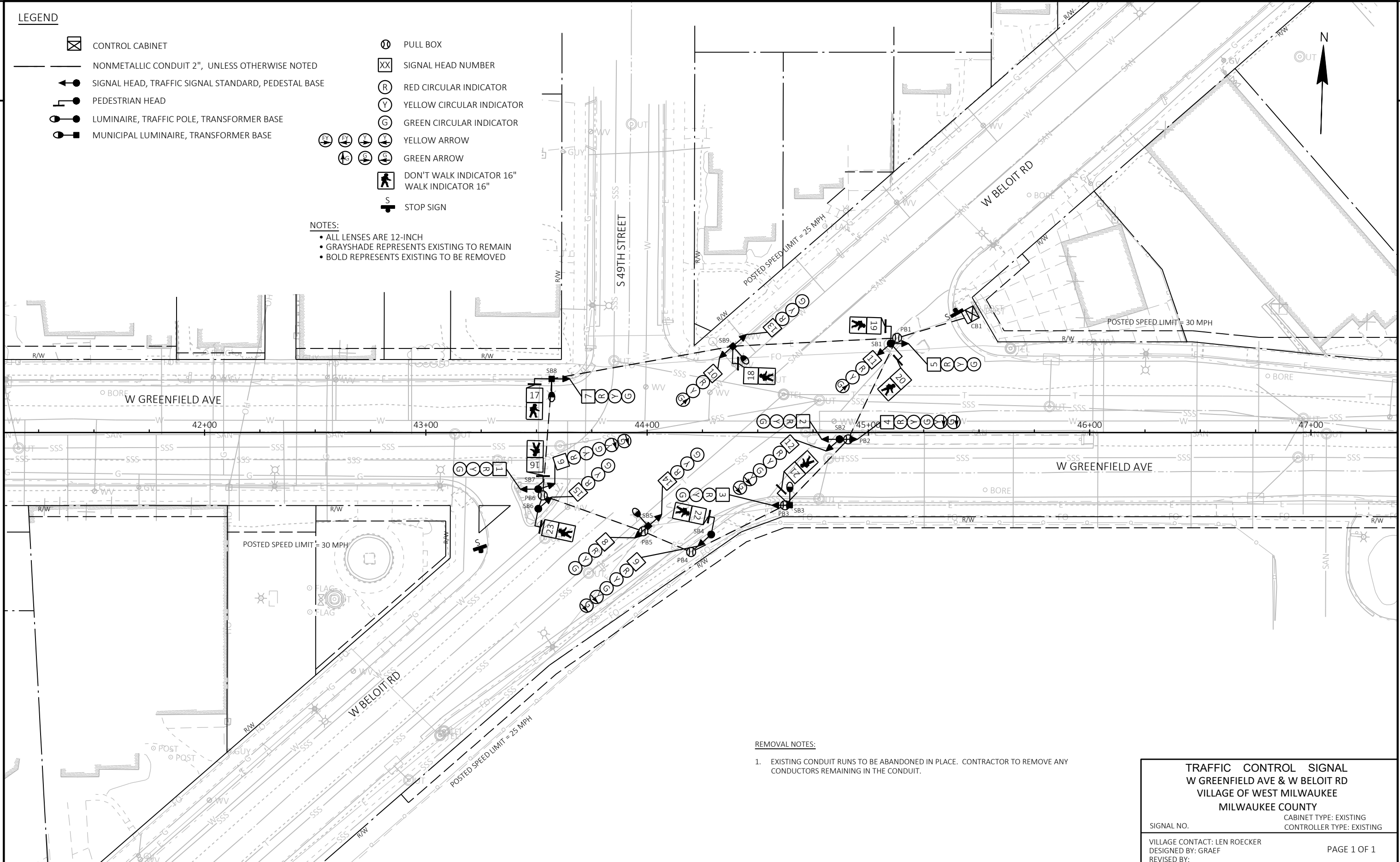

- REMOVAL NOTES:
1. EXISTING CONDUIT RUNS TO BE ABANDONED IN PLACE. CONTRACTOR TO REMOVE ANY CONDUCTORS REMAINING IN THE CONDUIT.

TRAFFIC CONTROL SIGNAL	
W GREENFIELD AVE & W BELOIT RD	
VILLAGE OF WEST MILWAUKEE	
MILWAUKEE COUNTY	
SIGNAL NO.	CABINET TYPE: EXISTING
	CONTROLLER TYPE: EXISTING
VILLAGE CONTACT: LEN ROECKER	
DESIGNED BY: GRAEF	
REVISED BY:	
PAGE 1 OF 1	

LEGEND

- CONTROL CABINET
- NONMETALLIC CONDUIT 2", UNLESS OTHERWISE NOTED
- SIGNAL HEAD, TRAFFIC SIGNAL STANDARD, PEDESTAL BASE
- MONOTUBE BASE, POLE, 15'-30' ARM
- MONOTUBE BASE TYPE 10 SPECIAL, POLE, 35'-45' ARM
- PEDESTRIAN HEAD WITH PUSH BUTTON
- PUSH BUTTON
- LUMINAIRE, TRAFFIC POLE, TRANSFORMER BASE
- VIDEO DETECTION AREA
- VIDEO DETECTION CAMERA
- EVP DESIGNATOR
- EVP DETECTOR HEAD
- CONFIRMATION LIGHT
- SECURITY CAMERA

- PULL BOX, 24" X 42"
- SIGNAL HEAD NUMBER
- RED CIRCULAR INDICATOR
- YELLOW CIRCULAR INDICATOR
- GREEN CIRCULAR INDICATOR
- RED ARROW
- YELLOW ARROW
- GREEN ARROW
- DON'T WALK INDICATOR 16"
- WALK INDICATOR 16"
- STOP SIGN

NOTES:
 • ALL LENSES ARE 12-INCH
 • GRAYSHADE REPRESENTS EXISTING

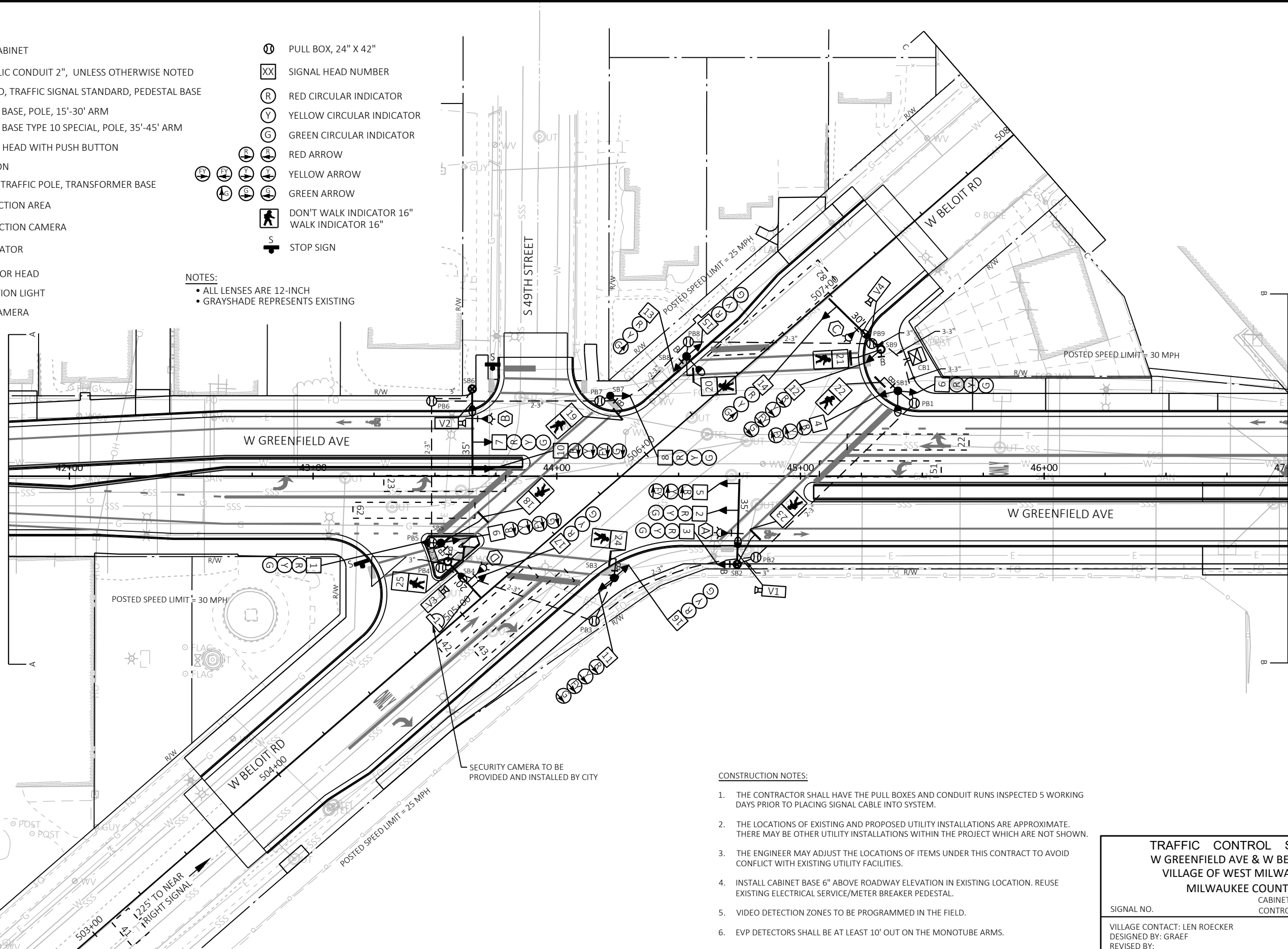

CONSTRUCTION NOTES:

1. THE CONTRACTOR SHALL HAVE THE PULL BOXES AND CONDUIT RUNS INSPECTED 5 WORKING DAYS PRIOR TO PLACING SIGNAL CABLE INTO SYSTEM.
2. THE LOCATIONS OF EXISTING AND PROPOSED UTILITY INSTALLATIONS ARE APPROXIMATE. THERE MAY BE OTHER UTILITY INSTALLATIONS WITHIN THE PROJECT WHICH ARE NOT SHOWN.
3. THE ENGINEER MAY ADJUST THE LOCATIONS OF ITEMS UNDER THIS CONTRACT TO AVOID CONFLICT WITH EXISTING UTILITY FACILITIES.
4. INSTALL CABINET BASE 6" ABOVE ROADWAY ELEVATION IN EXISTING LOCATION. REUSE EXISTING ELECTRICAL SERVICE/METER BREAKER PEDESTAL.
5. VIDEO DETECTION ZONES TO BE PROGRAMMED IN THE FIELD.
6. EVP DETECTORS SHALL BE AT LEAST 10' OUT ON THE MONOTUBE ARMS.

TRAFFIC CONTROL SIGNAL
W GREENFIELD AVE & W BELOIT RD
VILLAGE OF WEST MILWAUKEE
MILWAUKEE COUNTY

SIGNAL NO. _____ CABINET TYPE: TS2
 CONTROLLER TYPE: EPAC

VILLAGE CONTACT: LEN ROECKER
 DESIGNED BY: GRAEF
 REVISED BY: _____

PAGE 1 OF 3

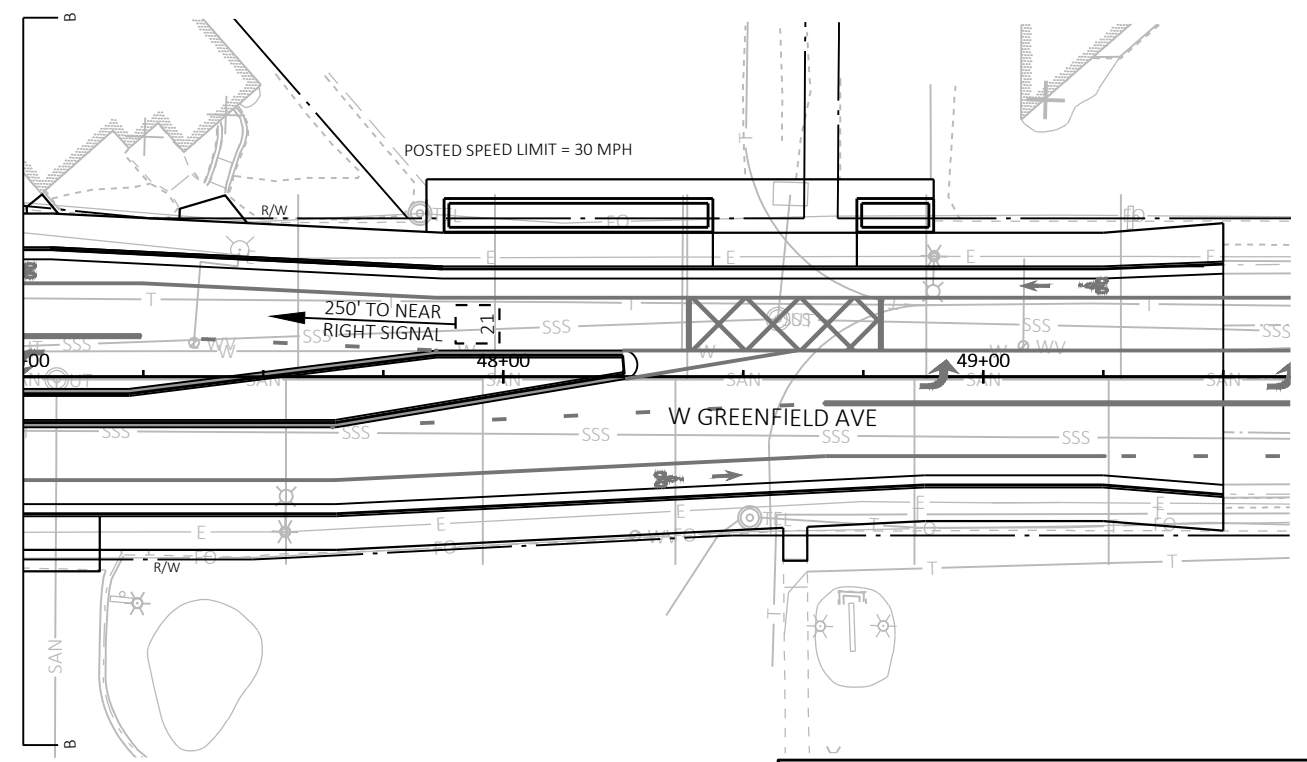
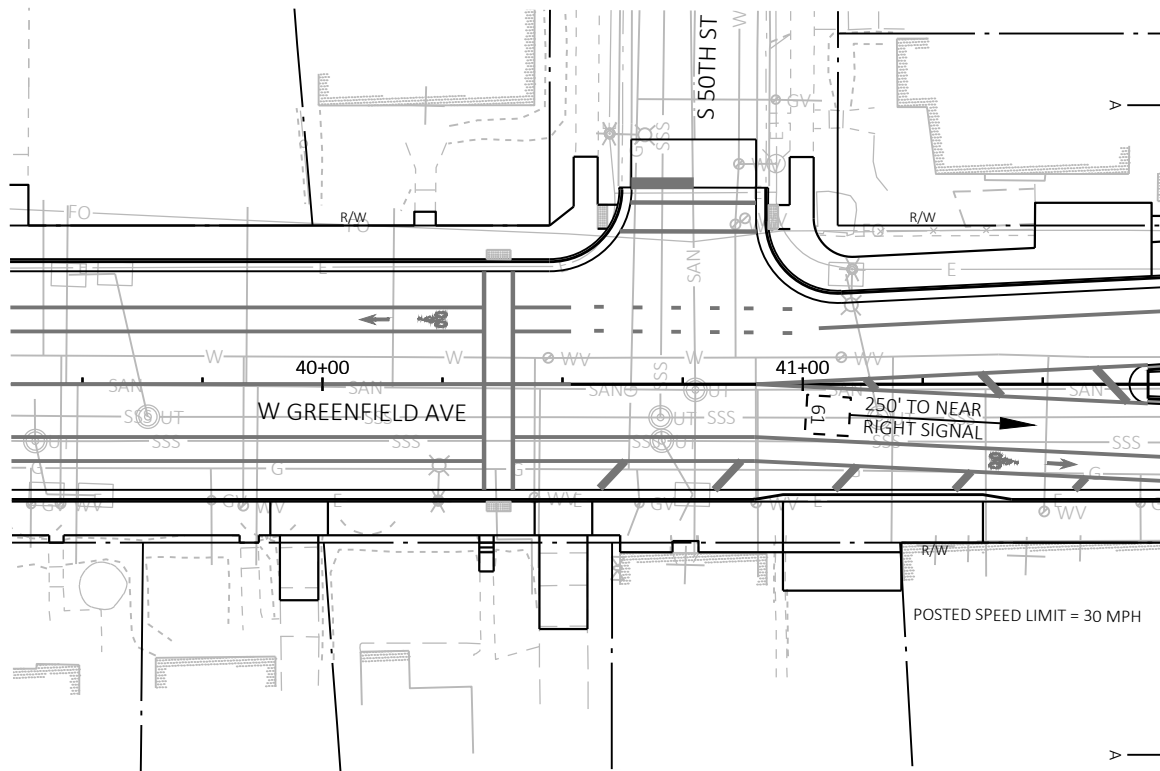
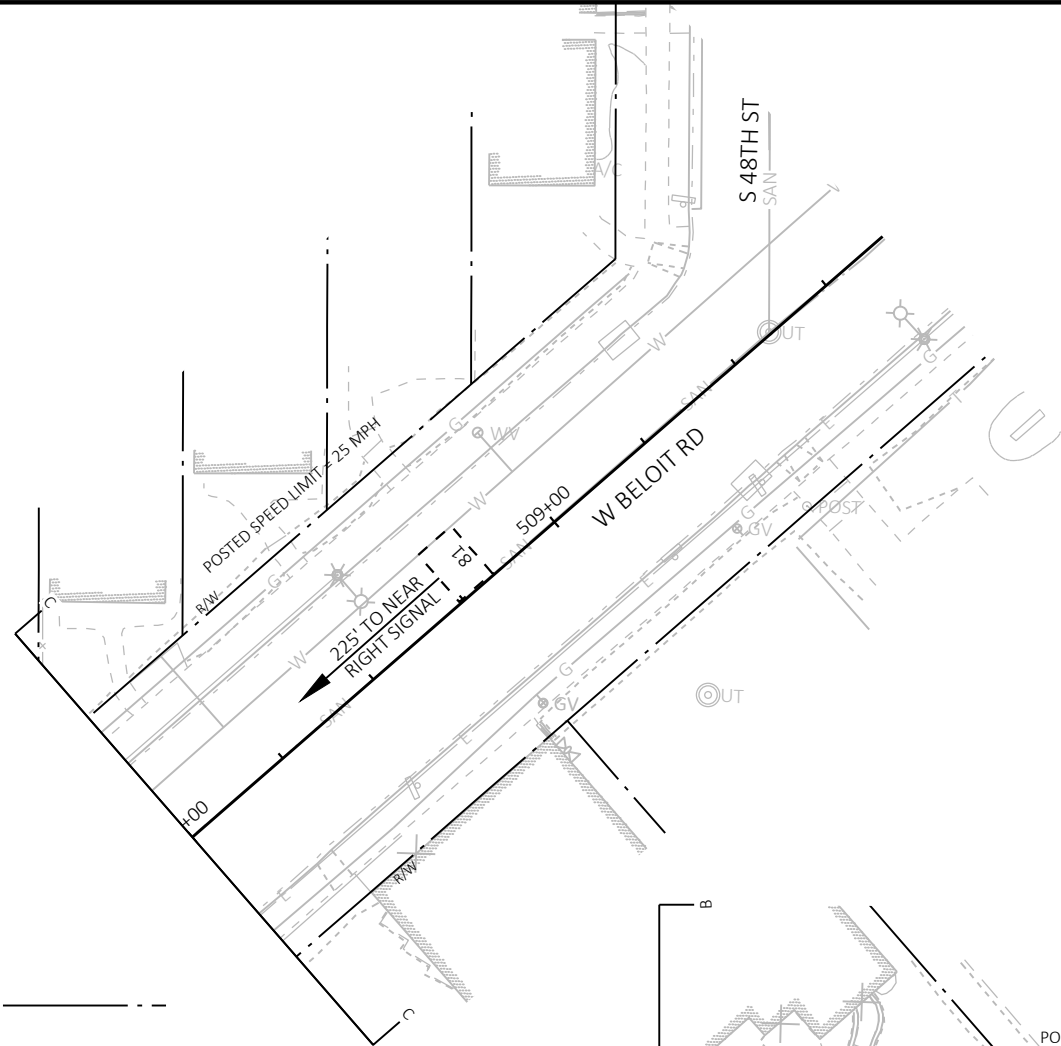

TRAFFIC CONTROL SIGNAL
W GREENFIELD AVE & W BELOIT RD
VILLAGE OF WEST MILWAUKEE
MILWAUKEE COUNTY

SIGNAL NO.

VILLAGE CONTACT: LEN ROECKER
 DESIGNED BY: GRAEF
 REVISED BY:

PAGE 2 OF 3

	HEAD NUMBERS	FLASH
Ø1		
Ø2	6,7,8	R
Ø3		
Ø4	13,14	R
Ø5	9,10	-
Ø6	1,2,3	R
Ø7		
Ø8	15,16,17	R
Ø2P	20,21	--
Ø4P	22,23	--
Ø6P	24,25	--
Ø8P	18,19	--
OLA	4,5	R
OLB		
OLC	9,10	R
OLD		
OLG	11,12	R

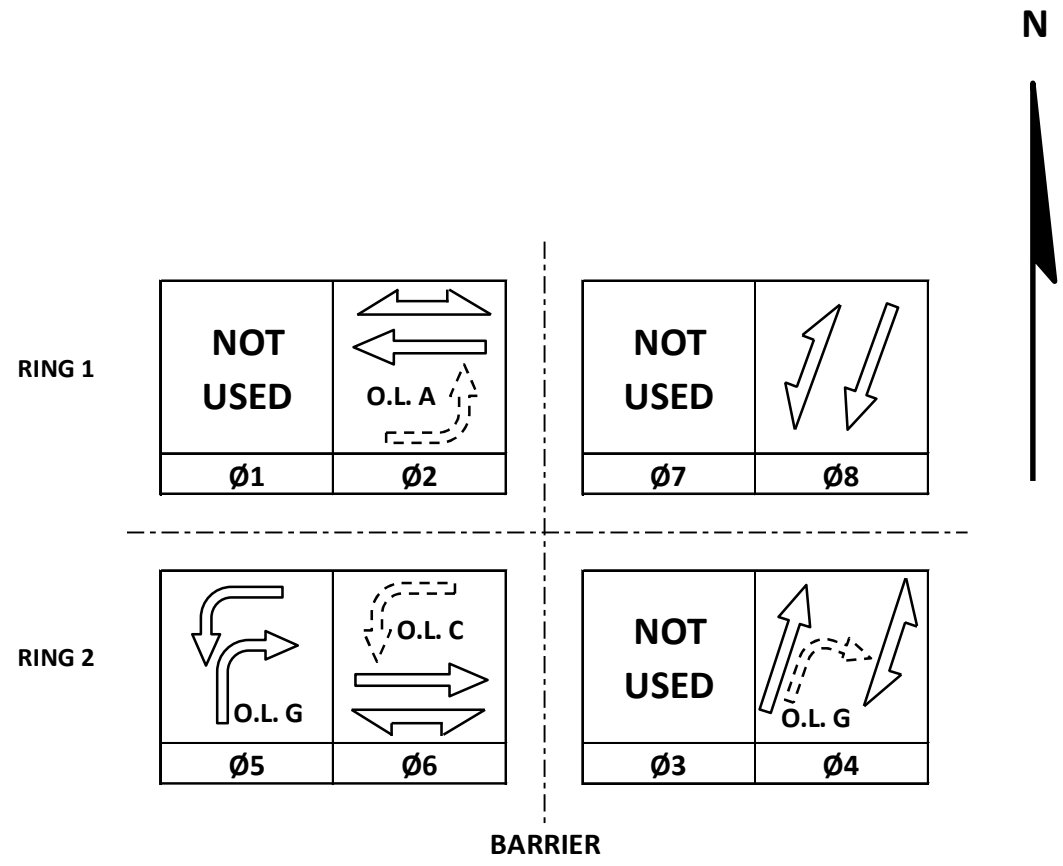

CONTROLLER LOGIC

PHASE NUMBER	PHASE LOCKING	DUAL ENTRY W / Ø	PHASE RECALL	PHASE ACTIVE
1				
2	X	5	MIN	X
3				
4		8		X
5		2		X
6	X	2	MIN	X
7				
8		4		X

TYPE OF INTERCONNECT/COMMUNICATION	
NONE	X
CLOSED LOOP	
TWISTED PAIR	
FIBER OPTIC*	
FIBER OPTIC (ETHERNET)	
RADIO	
CELL MODEM	

TYPE OF COORDINATION	
NONE	X
TBC	
TRAFFIC RESPONSIVE	
ADAPTIVE	
*LOCATION OF MASTER CONTROLLER NO:	S-
SIGNAL SYSTEM NO:	SS-

TYPE OF LIGHTING	
BY OTHER AGENCY	
IN TRAFFIC CABINET	X
IN SEPARATE DOT LIGHTING CABINET	

EMERGENCY VEHICLE PREEMPTION SEQUENCE

EMERGENCY VEHICLE PREEMPTOR	A	B	C	D
MOVEMENT				
PHASE	2+5	6+2	4+8	8+4

AFTER PREEMPTION SEQUENCE 2+5 OR 6+2, CONTROLLER SHALL RETURN TO PHASES 2+5
 AFTER PREEMPTION SEQUENCE 4+8 OR 8+4, CONTROLLER SHALL RETURN TO PHASES 4+8.

TYPE OF PRE-EMPT	
NONE	
RAILROAD	
EMERGENCY VEHICLE	X
GTT	X
TOMAR	
HARDWIRE	
OTHER	
LIFT BRIDGE	
QUEUE DETECTION	

DETECTOR LOGIC

DETECTOR INPUT	3	1	7	5	11	9	15	13
PLAN LOOP DETECTOR*(S)	21	23	42	51	62	82		
ASSIGNED PHASE	2	2	4	5	6	8		
OPERATION MODE	VEH	VEH	VEH	VEH	VEH	VEH	VEH	VEH
SWITCH								
EXTEND	X							
DELAY								

DETECTOR INPUT	19	17	23	21	27	25	31	29
PLAN LOOP DETECTOR*(S)								
ASSIGNED PHASE								
OPERATION MODE	VEH	VEH	VEH	VEH	VEH	VEH	VEH	VEH
SWITCH								
EXTEND								
DELAY								

DETECTOR INPUT	4	2	8	6	12	10	16	14
PLAN LOOP DETECTOR*(S)	22	41	43	61	81			
ASSIGNED PHASE	2	4	4	6	8			
OPERATION MODE	VEH	VEH	VEH	VEH	VEH	VEH	VEH	VEH
SWITCH								
EXTEND		X		X	X			
DELAY			X					

DETECTOR INPUT	20	18	24	22	28	26	32	30
PLAN LOOP DETECTOR*(S)								
ASSIGNED PHASE								
OPERATION MODE	VEH	VEH	VEH	VEH	VEH	VEH	VEH	VEH
SWITCH								
EXTEND								
DELAY								

- GENERAL NOTES:**
1. ANY ACTUATED PHASE FOR WHICH THERE IS NO CALL SHALL BE SKIPPED
 2. WHEN ONE PHASE IS ON ALONE, ANY NON-CONFLICTING PHASE MAY START TIMING CONCURRENTLY WITHOUT A CLEARANCE INTERVAL.

W GREENFIELD AVE & W BELOIT RD	
VILLAGE OF WEST MILWAUKEE	
MILWAUKEE COUNTY	
SIGNAL NO:	CABINET TYPE: TS2
CONTROLLER TYPE: EPAC	
DATE: 8/2023	PAGE NO. 3 OF 3

PROJECT ID:	2230-07-73
INTERSECTION:	W GREENFIELD AVE & W BELOIT RD

SIGNAL WIRE COLOR CODING	BLK-BLACK	RED-RED	GRN-GREEN
	WHT-WHITE	BLU-BLUE	ORG-ORANGE

CB1 TO	AWG14 # OF CONDUCTORS	HEAD NO.	SIGNAL INDICATION WIRE COLOR								D/WALK	WALK	PED BUTTON	PED BUTTON
			RED	YELLOW	GREEN	<RED>	<YELLOW>	<GREEN>	FLASHING <YELLOW>					
SB1	12	4				RED	ORG							
		6	RED/BLK	ORG/BLK	GRN/BLK									
		22 B								BLK	BLU		WHT/BLK	BLU/BLK
SB2	15	2	RED	ORG	GRN									
		3	RED	ORG	GRN									
		5 23 B				RED/BLK	ORG/BLK		BLK/WHT			BLK	BLU	
SB3	15	11				RED	ORG	GRN	BLK/WHT					
		16	RED/BLK	ORG/BLK	GRN/BLK									
		24 B									BLK	BLU		WHT/BLK BLU/BLK
SB4	12	17	RED	ORG	GRN									
		25 B									BLK	BLU		WHT/BLK BLU/BLK
		1	RED	ORG	GRN									
SB5	15	9				RED/BLK	ORG/BLK	GRN/BLK	BLK/WHT					
		18 B									BLK	BLU		WHT/BLK BLU/BLK
		7	RED	ORG	GRN									
SB6	15	10				RED/BLK	ORG/BLK	GRN/BLK	BLK/WHT					
		8	RED	ORG	GRN									
		19 B									BLK	BLU		WHT/BLK BLU/BLK
SB8	12	13	RED	ORG					GRN					
		15	RED/BLK	ORG/BLK	GRN/BLK									
		20 B									BLK	BLU		WHT/BLK BLU/BLK
SB9	15	12	RED/BLK	ORG/BLK				GRN/BLK						
		14				RED	ORG	GRN	BLK/WHT					
		21 B									BLK	BLU		WHT/BLK BLU/BLK

EQUIPMENT GROUNDING CONDUCTOR 10 AWG GRN XLP	
FROM	TO
CB1	SB1
SB1	SB2
SB2	SB3
SB3	SB4
SB4	SB5
SB5	SB6
SB6	SB7
SB7	SB8
SB8	SB9
SB9	CB1

LIGHTING UF 10 AWG	
FROM	TO
CB1	SB1
SB1	SB2
SB2	SB4
CB1	SB9
SB9	SB8
SB8	SB6

PULL BOX BONDING JUMPER 10 AWG GRN XLP	
FROM	TO
PB1	SB1
PB2	SB2
PB3	SB3
PB4	SB4
PB5	SB5
PB6	SB6
PB7	SB7
PB8	SB8
PB9	SB9

EMERGENCY VEHICLE PREEMPTION	
FROM	TO
CB1	HEAD A (SB2)
CB1	HEAD B (SB6)
CB1	HEAD C (SB9)
CB1	HEAD D (SB4)

- NOTES:
- *USE WHITE CONDUCTOR IN THE SIGNAL CABLE AS THE GROUNDED CONDUCTOR FOR ALL TRAFFIC SIGNAL INDICATIONS.
 - *ENSURE THE GROUNDED CONDUCTOR IN THE FEEDER CABLE AND THE POLE CABLES ARE BOTH 18" LONGER THAN THE UNGROUNDED CONDUCTORS.
 - *RECONNECT THE GROUNDING CONDUCTORS WHENEVER THE CIRCUIT HAS BEEN INTERRUPTED TO ENSURE THE GROUNDING CIRCUIT IS COMPLETE.

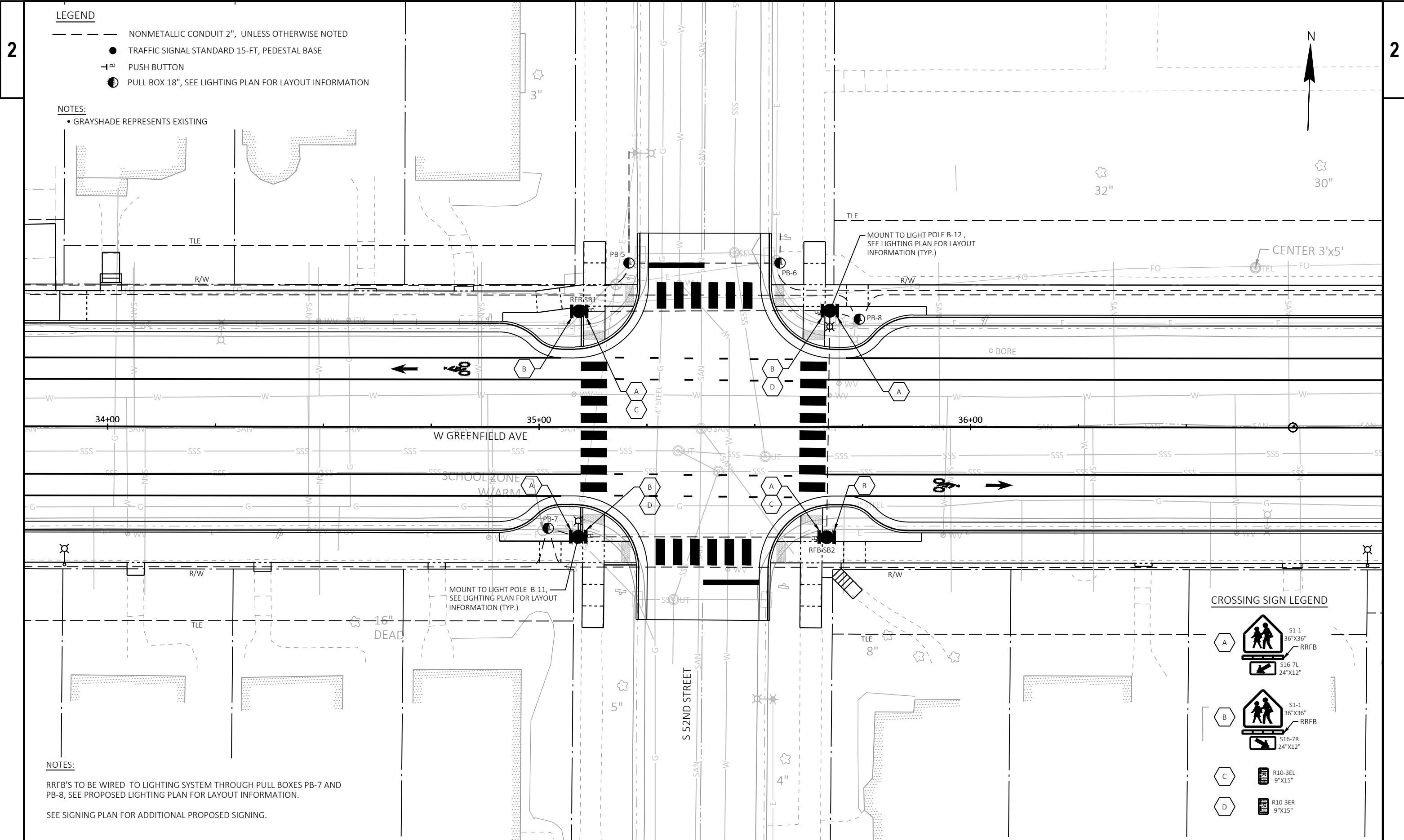

2

2

- LEGEND**
- NONMETALLIC CONDUIT 2", UNLESS OTHERWISE NOTED
 - TRAFFIC SIGNAL STANDARD 15-FT, PEDESTAL BASE
 - ⊖^{1"} PUSH BUTTON
 - ⊖^{18"} PULL BOX 18", SEE LIGHTING PLAN FOR LAYOUT INFORMATION

NOTES:

- GRAYSHADE REPRESENTS EXISTING

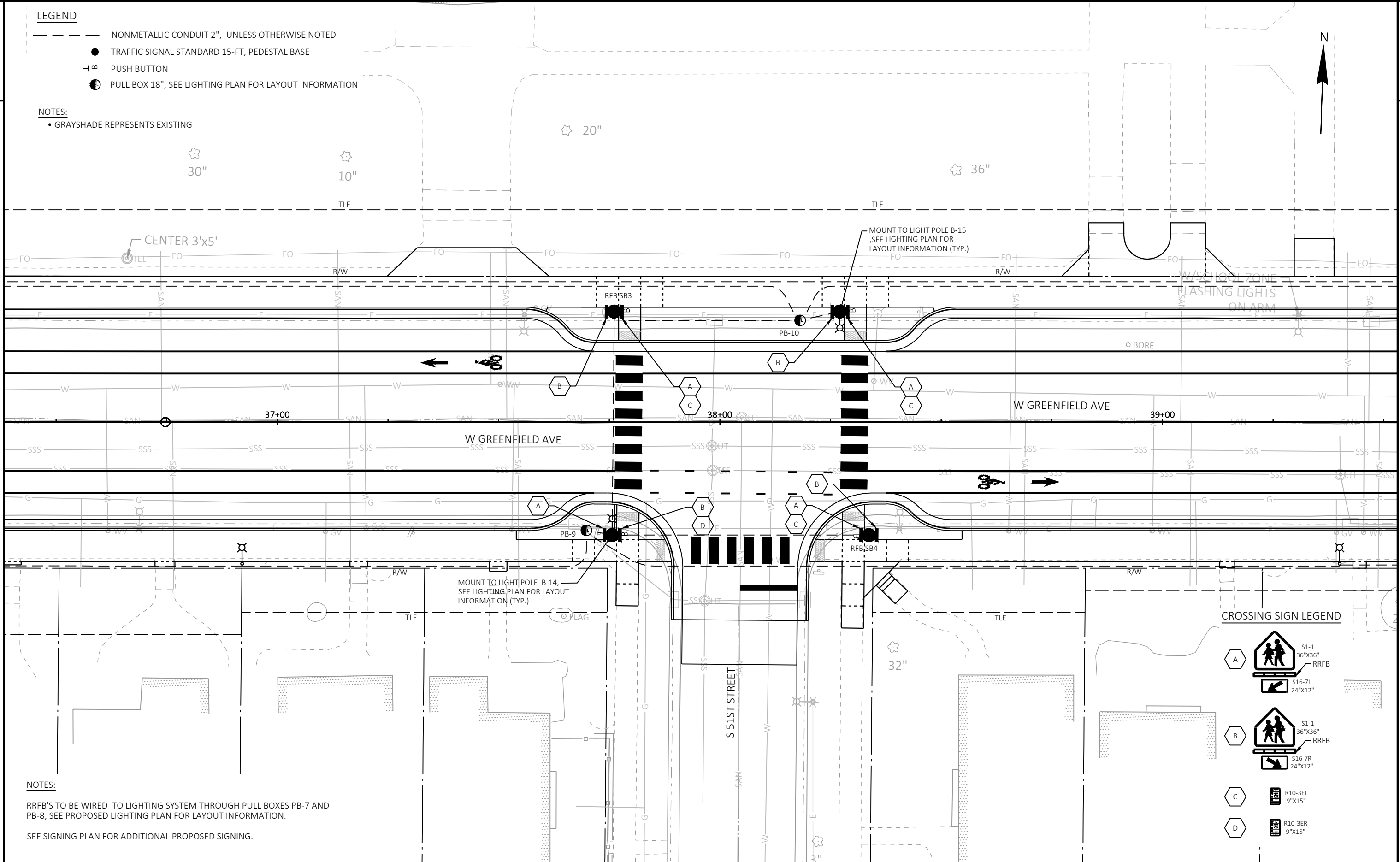

NOTES:

RRFB'S TO BE WIRED TO LIGHTING SYSTEM THROUGH PULL BOXES PB-7 AND PB-8, SEE PROPOSED LIGHTING PLAN FOR LAYOUT INFORMATION.

SEE SIGNING PLAN FOR ADDITIONAL PROPOSED SIGNING.

CROSSING SIGN LEGEND

- A S1-1 36"x36" RRFB
- S16-7L 24"x12"
- B S1-1 36"x36" RRFB
- S16-7R 24"x12"
- C R10-3EL 9"x15"
- D R10-3ER 9"x15"

LEGEND

- 1 MARKING LINE EPOXY 4-INCH, WHITE
- 2 MARKING LINE EPOXY 4-INCH, YELLOW
- 3 MARKING LINE EPOXY 4-INCH, WHITE (2' LINE, 6' SKIP)
- 4 MARKING CROSSWALK EPOXY TRANSVERSE LINE 6-INCH
- 5 MARKING LINE EPOXY 8-INCH, WHITE
- 6 MARKING LINE EPOXY 8-INCH, WHITE (3' LINE, 9' SKIP)
- 7 MARKING DIAGONAL EPOXY 12-INCH (25' SPACING - WHITE)
- 8 MARKING STOP LINE EPOXY 18-INCH, WHITE
- 9 MARKING CROSSWALK EPOXY BLOCK STYLE 24-INCH
- 10 MARKING ARROW EPOXY, TYPE 2, WHITE
- 11 MARKING WORD EPOXY, WHITE
- 12 MARKING ARROW BIKE LANE EPOXY
- 13 MARKING SYMBOL BIKE LANE EPOXY
- 14 MARKING LINE EPOXY 4 INCH, WHITE (12.5' LINE, 37.5' SKIP)
- 15 MARKING DIAGONAL EPOXY 12-INCH (25' SPACING - YELLOW)
- 16 MARKING DIAGONAL EPOXY 6-INCH (8' SPACING - WHITE)

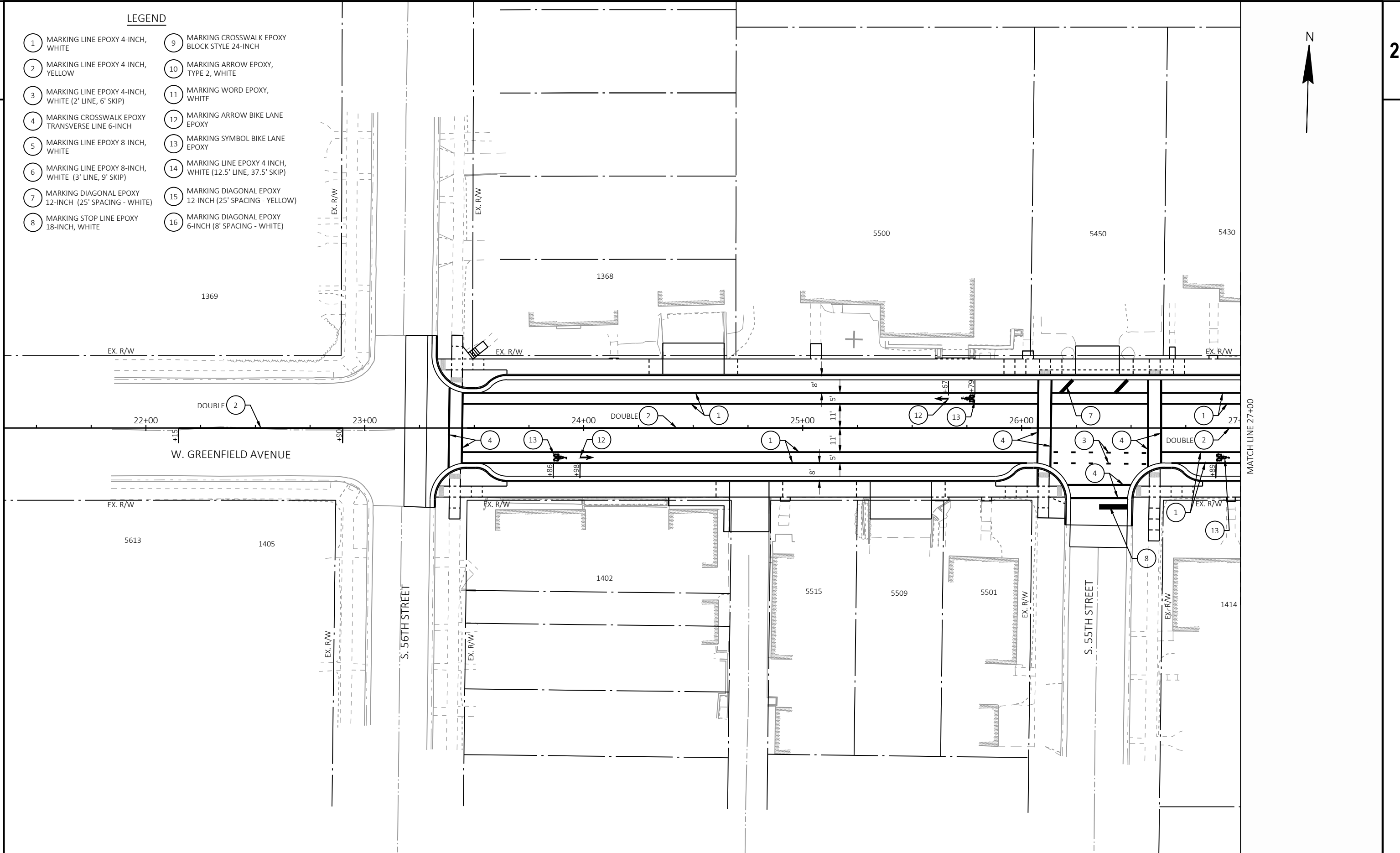

LEGEND

- 1 MARKING LINE EPOXY 4-INCH, WHITE
- 2 MARKING LINE EPOXY 4-INCH, YELLOW
- 3 MARKING LINE EPOXY 4-INCH, WHITE (2' LINE, 6' SKIP)
- 4 MARKING CROSSWALK EPOXY TRANSVERSE LINE 6-INCH
- 5 MARKING LINE EPOXY 8-INCH, WHITE
- 6 MARKING LINE EPOXY 8-INCH, WHITE (3' LINE, 9' SKIP)
- 7 MARKING DIAGONAL EPOXY 12-INCH (25' SPACING - WHITE)
- 8 MARKING STOP LINE EPOXY 18-INCH, WHITE
- 9 MARKING CROSSWALK EPOXY BLOCK STYLE 24-INCH
- 10 MARKING ARROW EPOXY, TYPE 2, WHITE
- 11 MARKING WORD EPOXY, WHITE
- 12 MARKING ARROW BIKE LANE EPOXY
- 13 MARKING SYMBOL BIKE LANE EPOXY
- 14 MARKING LINE EPOXY 4 INCH, WHITE (12.5' LINE, 37.5' SKIP)
- 15 MARKING DIAGONAL EPOXY 12-INCH (25' SPACING - YELLOW)
- 16 MARKING DIAGONAL EPOXY 6-INCH (8' SPACING - WHITE)

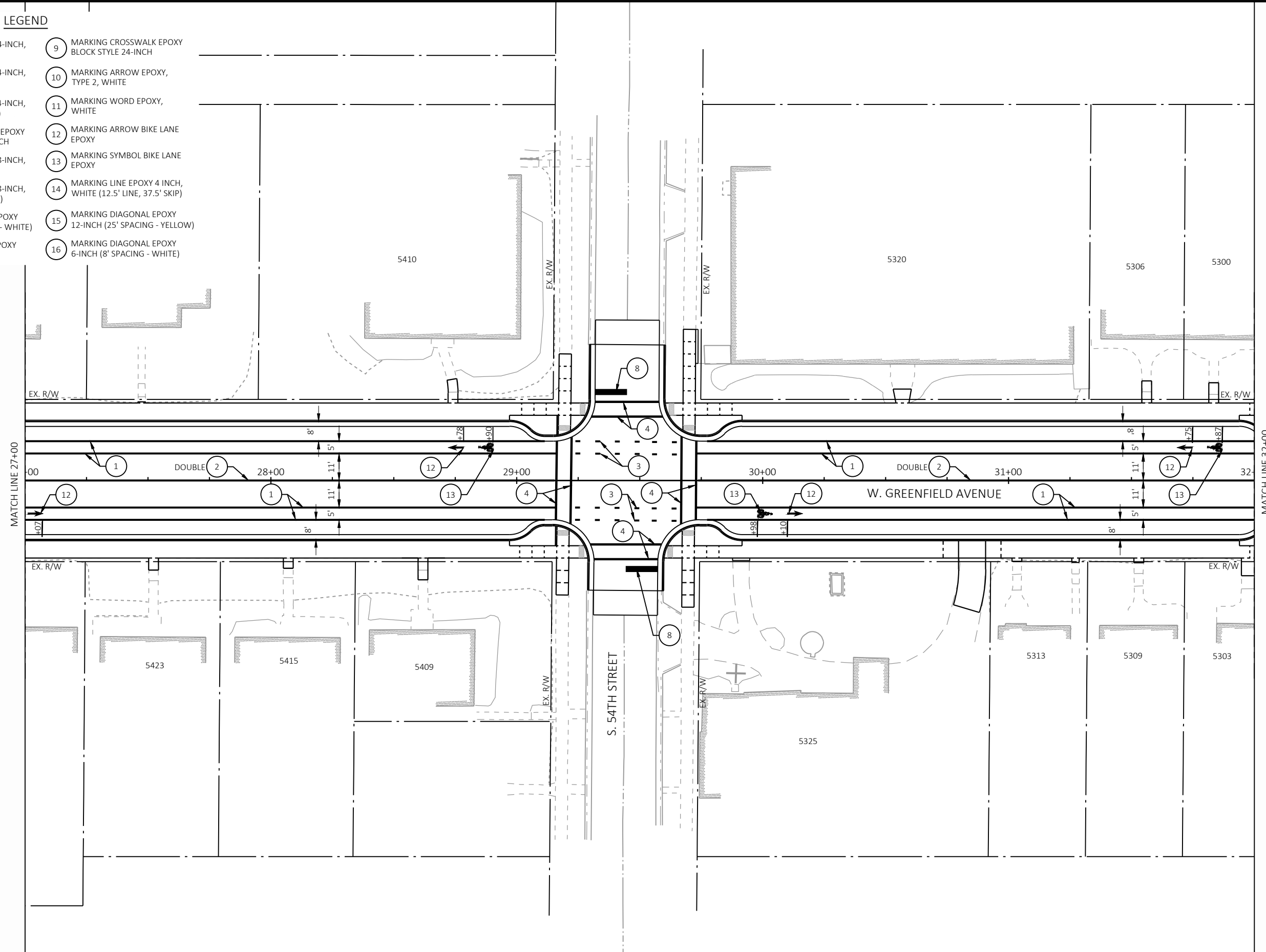

LEGEND

- 1 MARKING LINE EPOXY 4-INCH, WHITE
- 2 MARKING LINE EPOXY 4-INCH, YELLOW
- 3 MARKING LINE EPOXY 4-INCH, WHITE (2' LINE, 6' SKIP)
- 4 MARKING CROSSWALK EPOXY TRANSVERSE LINE 6-INCH
- 5 MARKING LINE EPOXY 8-INCH, WHITE
- 6 MARKING LINE EPOXY 8-INCH, WHITE (3' LINE, 9' SKIP)
- 7 MARKING DIAGONAL EPOXY 12-INCH (25' SPACING - WHITE)
- 8 MARKING STOP LINE EPOXY 18-INCH, WHITE
- 9 MARKING CROSSWALK EPOXY BLOCK STYLE 24-INCH
- 10 MARKING ARROW EPOXY, TYPE 2, WHITE
- 11 MARKING WORD EPOXY, WHITE
- 12 MARKING ARROW BIKE LANE EPOXY
- 13 MARKING SYMBOL BIKE LANE EPOXY
- 14 MARKING LINE EPOXY 4 INCH, WHITE (12.5' LINE, 37.5' SKIP)
- 15 MARKING DIAGONAL EPOXY 12-INCH (25' SPACING - YELLOW)
- 16 MARKING DIAGONAL EPOXY 6-INCH (8' SPACING - WHITE)

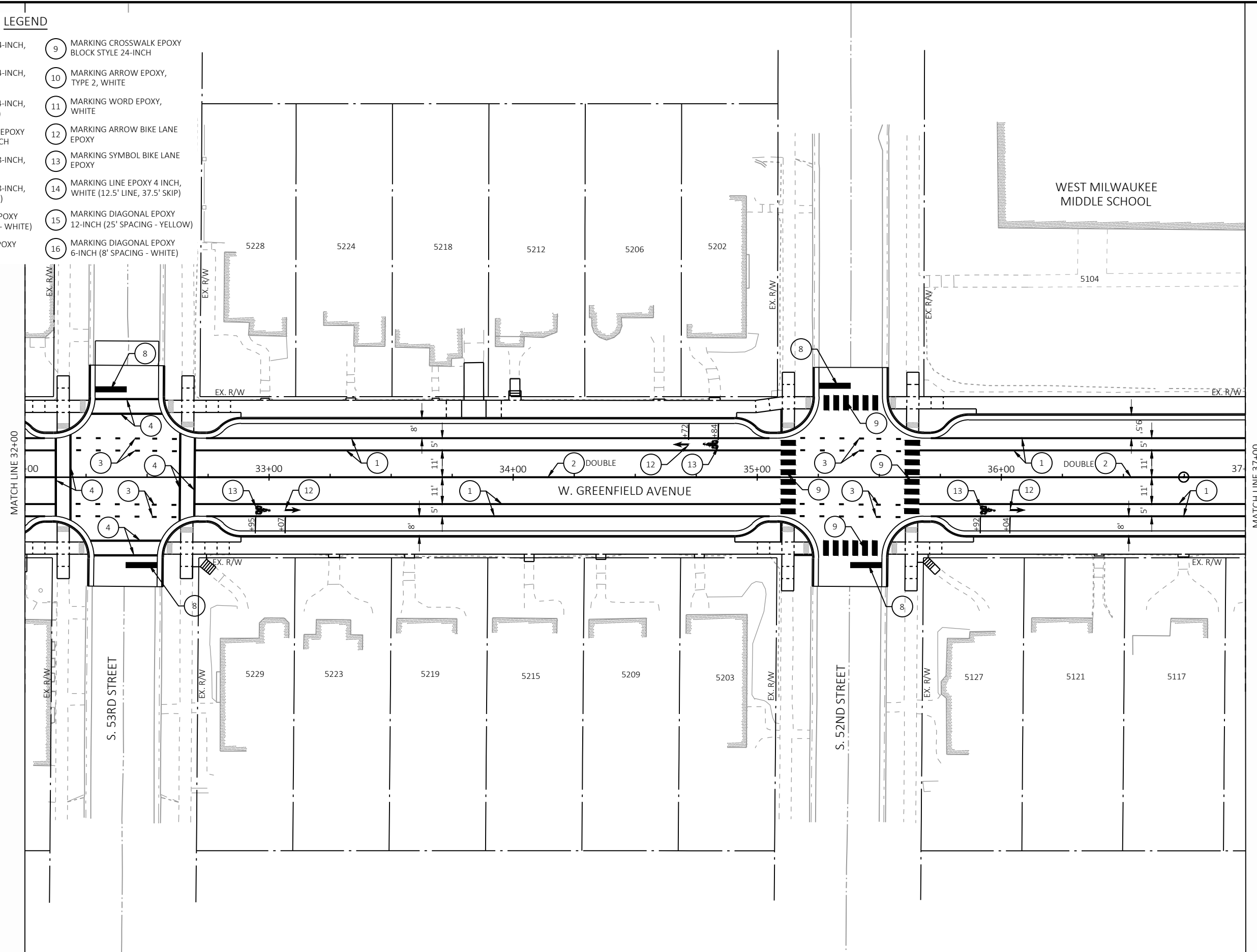

LEGEND

- 1 MARKING LINE EPOXY 4-INCH, WHITE
- 2 MARKING LINE EPOXY 4-INCH, YELLOW
- 3 MARKING LINE EPOXY 4-INCH, WHITE (2' LINE, 6' SKIP)
- 4 MARKING CROSSWALK EPOXY TRANSVERSE LINE 6-INCH
- 5 MARKING LINE EPOXY 8-INCH, WHITE
- 6 MARKING LINE EPOXY 8-INCH, WHITE (3' LINE, 9' SKIP)
- 7 MARKING DIAGONAL EPOXY 12-INCH (25' SPACING - WHITE)
- 8 MARKING STOP LINE EPOXY 18-INCH, WHITE
- 9 MARKING CROSSWALK EPOXY BLOCK STYLE 24-INCH
- 10 MARKING ARROW EPOXY, TYPE 2, WHITE
- 11 MARKING WORD EPOXY, WHITE
- 12 MARKING ARROW BIKE LANE EPOXY
- 13 MARKING SYMBOL BIKE LANE EPOXY
- 14 MARKING LINE EPOXY 4 INCH, WHITE (12.5' LINE, 37.5' SKIP)
- 15 MARKING DIAGONAL EPOXY 12-INCH (25' SPACING - YELLOW)
- 16 MARKING DIAGONAL EPOXY 6-INCH (8' SPACING - WHITE)

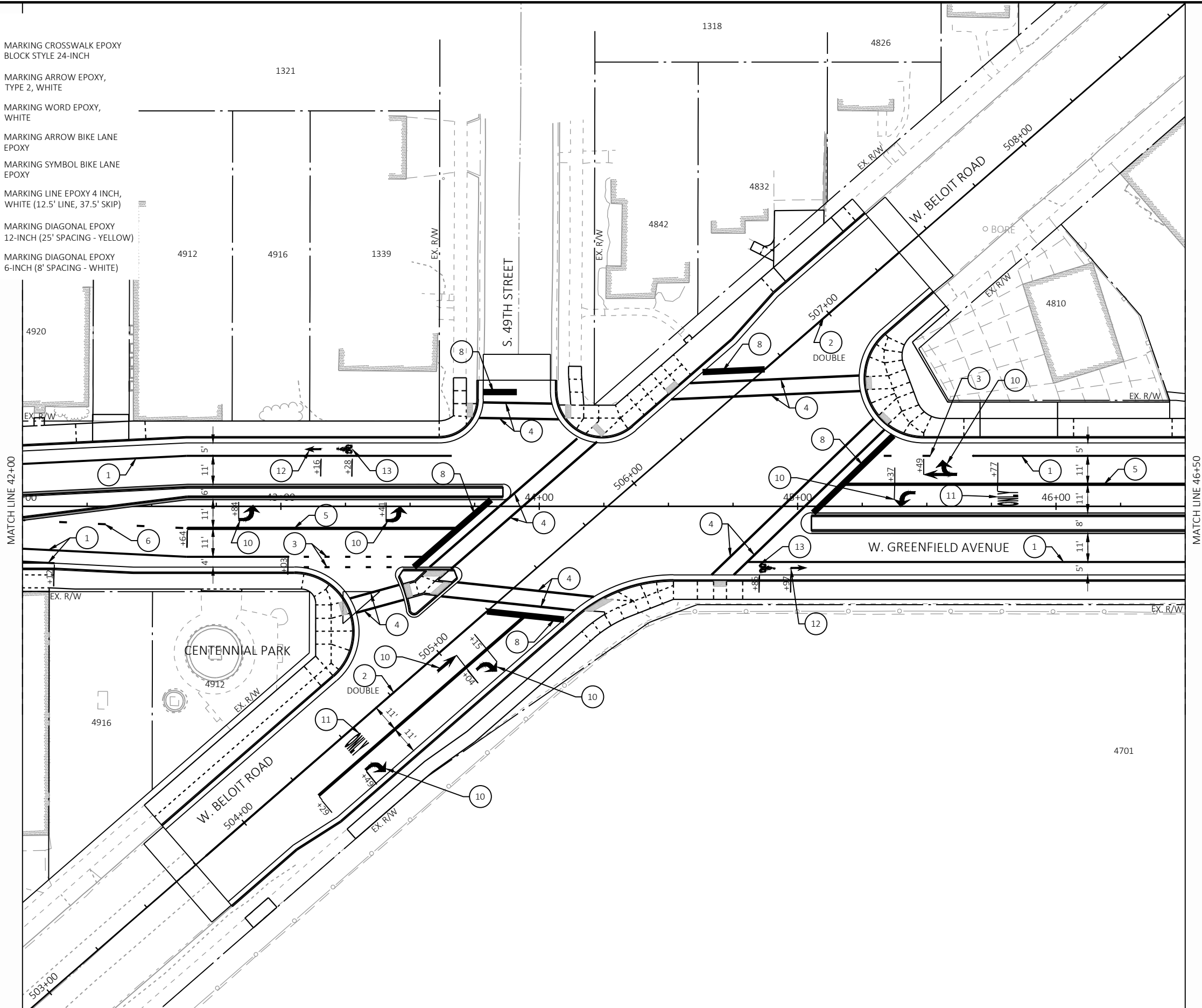

LEGEND

- 1 MARKING LINE EPOXY 4-INCH, WHITE
- 2 MARKING LINE EPOXY 4-INCH, YELLOW
- 3 MARKING LINE EPOXY 4-INCH, WHITE (2' LINE, 6' SKIP)
- 4 MARKING CROSSWALK EPOXY TRANSVERSE LINE 6-INCH
- 5 MARKING LINE EPOXY 8-INCH, WHITE
- 6 MARKING LINE EPOXY 8-INCH, WHITE (3' LINE, 9' SKIP)
- 7 MARKING DIAGONAL EPOXY 12-INCH (25' SPACING - WHITE)
- 8 MARKING STOP LINE EPOXY 18-INCH, WHITE
- 9 MARKING CROSSWALK EPOXY BLOCK STYLE 24-INCH
- 10 MARKING ARROW EPOXY, TYPE 2, WHITE
- 11 MARKING WORD EPOXY, WHITE
- 12 MARKING ARROW BIKE LANE EPOXY
- 13 MARKING SYMBOL BIKE LANE EPOXY
- 14 MARKING LINE EPOXY 4 INCH, WHITE (12.5' LINE, 37.5' SKIP)
- 15 MARKING DIAGONAL EPOXY 12-INCH (25' SPACING - YELLOW)
- 16 MARKING DIAGONAL EPOXY 6-INCH (8' SPACING - WHITE)

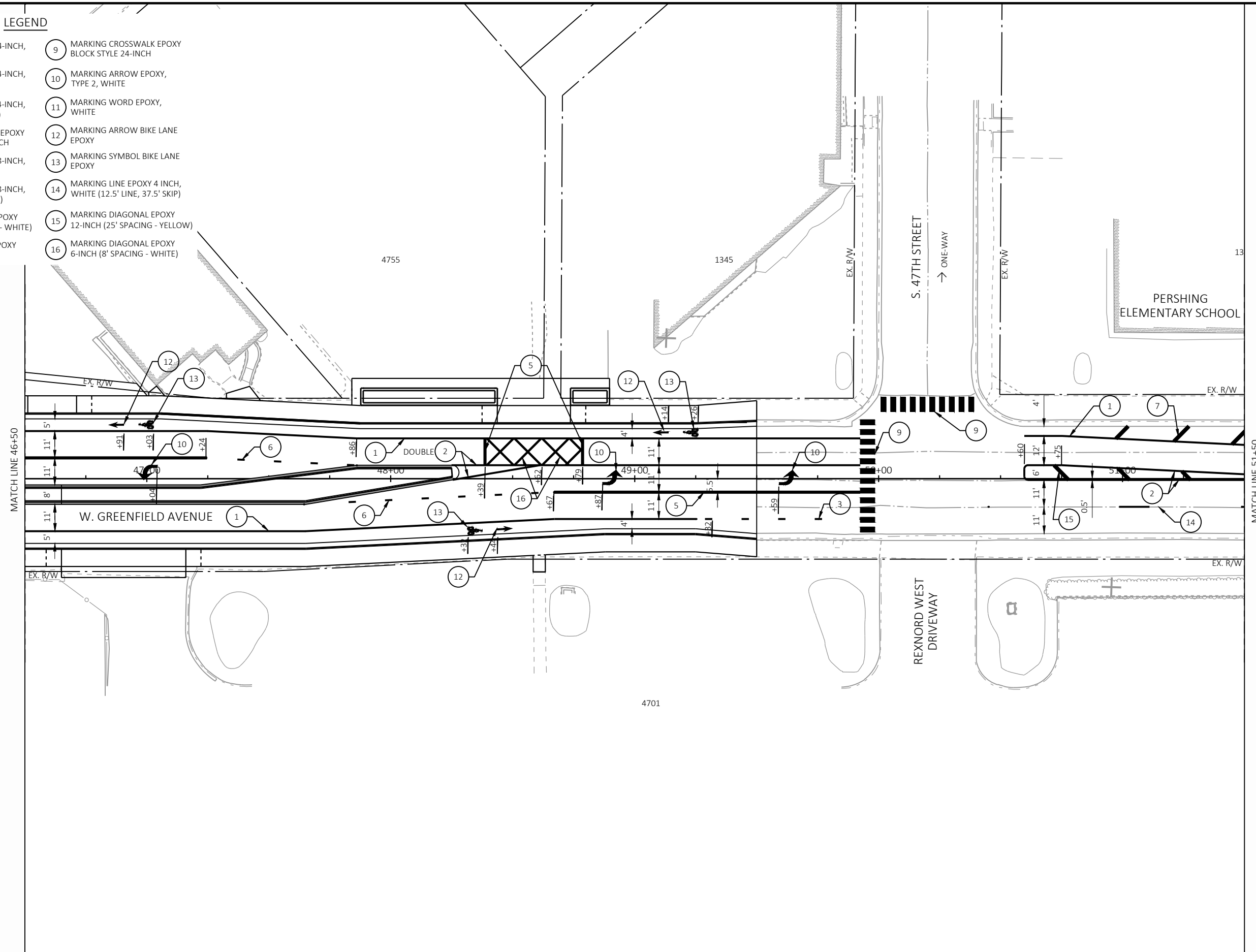





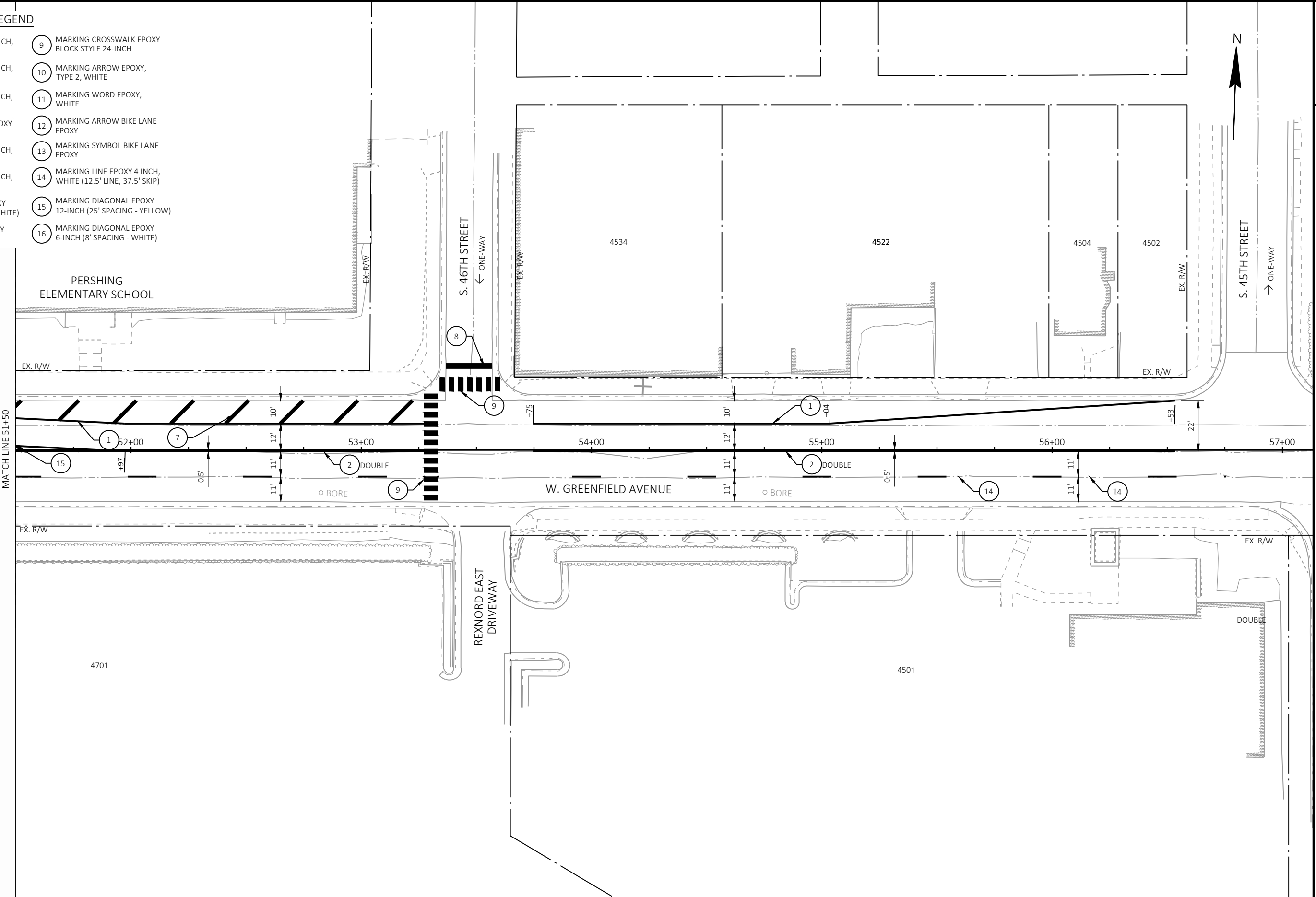

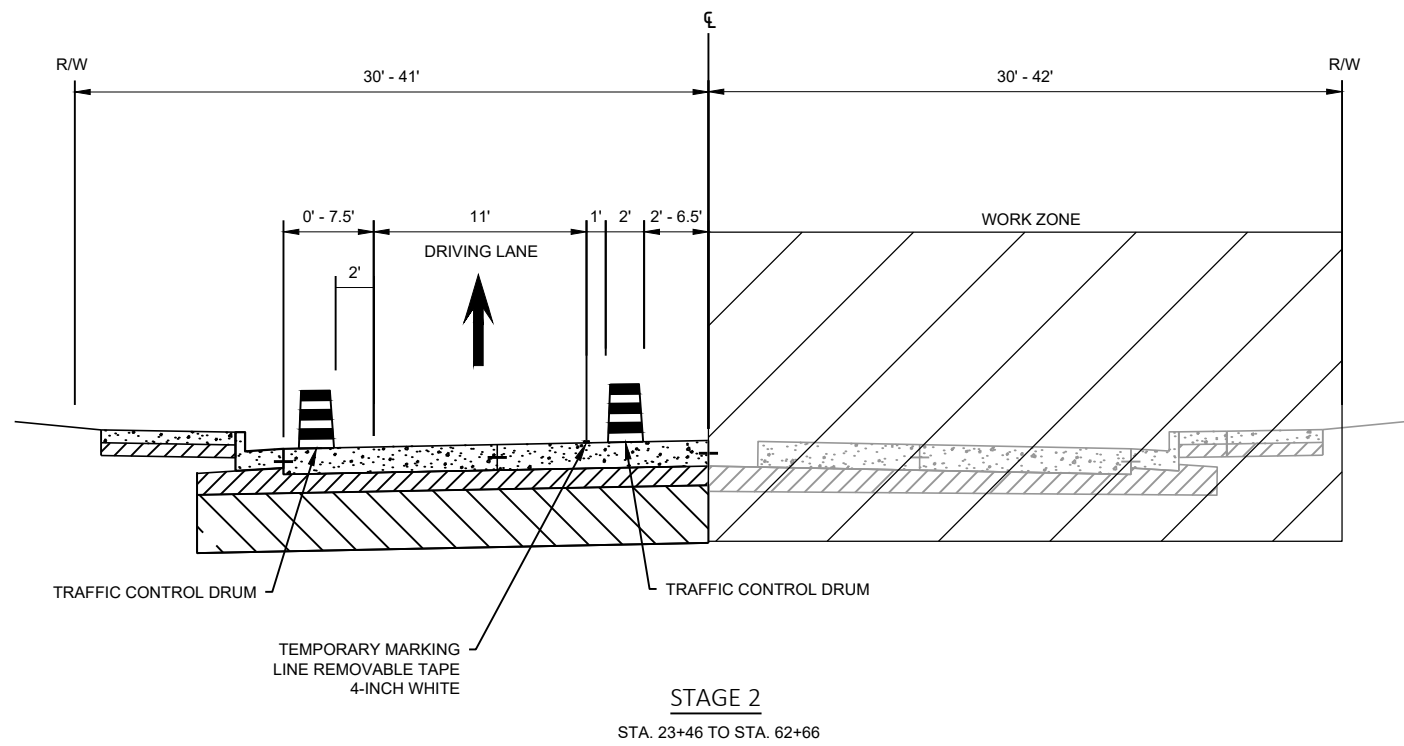
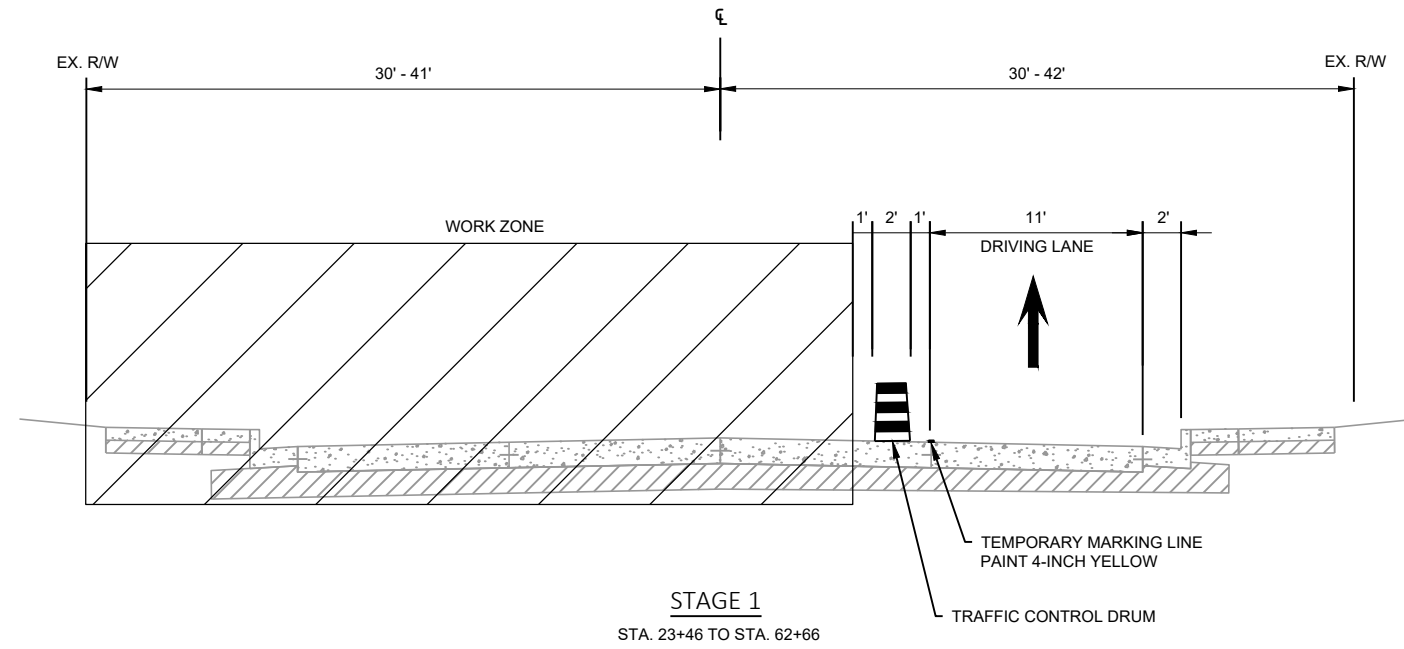





LEGEND

- 1 MARKING LINE EPOXY 4-INCH, WHITE
- 2 MARKING LINE EPOXY 4-INCH, YELLOW
- 3 MARKING LINE EPOXY 4-INCH, WHITE (2' LINE, 6' SKIP)
- 4 MARKING CROSSWALK EPOXY TRANSVERSE LINE 6-INCH
- 5 MARKING LINE EPOXY 8-INCH, WHITE
- 6 MARKING LINE EPOXY 8-INCH, WHITE (3' LINE, 9' SKIP)
- 7 MARKING DIAGONAL EPOXY 12-INCH (25' SPACING - WHITE)
- 8 MARKING STOP LINE EPOXY 18-INCH, WHITE
- 9 MARKING CROSSWALK EPOXY BLOCK STYLE 24-INCH
- 10 MARKING ARROW EPOXY, TYPE 2, WHITE
- 11 MARKING WORD EPOXY, WHITE
- 12 MARKING ARROW BIKE LANE EPOXY
- 13 MARKING SYMBOL BIKE LANE EPOXY
- 14 MARKING LINE EPOXY 4 INCH, WHITE (12.5' LINE, 37.5' SKIP)
- 15 MARKING DIAGONAL EPOXY 12-INCH (25' SPACING - YELLOW)
- 16 MARKING DIAGONAL EPOXY 6-INCH (8' SPACING - WHITE)





LEGEND

-  TYPE III BARRICADE WITH TWO TYPE "A" LIGHTS
-  TYPE III BARRICADE WITH ATTACHED SIGN AND TWO TYPE "A" LIGHTS
-  TRAFFIC CONTROL DRUM
-  TRAFFIC CONTROL DRUM WITH TYPE "C" STEADY BURN LIGHT
-  TEMPORARY PEDESTRIAN BARRICADE
-  TEMPORARY CURB RAMP
-  TEMPORARY PEDESTRIAN SURFACE ASPHALT
-  SIGN ON PERMANENT SUPPORT
-  SIGN ON TEMPORARY SUPPORT
-  WORK AREA
-  DIRECTION OF TRAFFIC
-  PCMS
-  PORTABLE CHANGEABLE MESSAGE BOARD

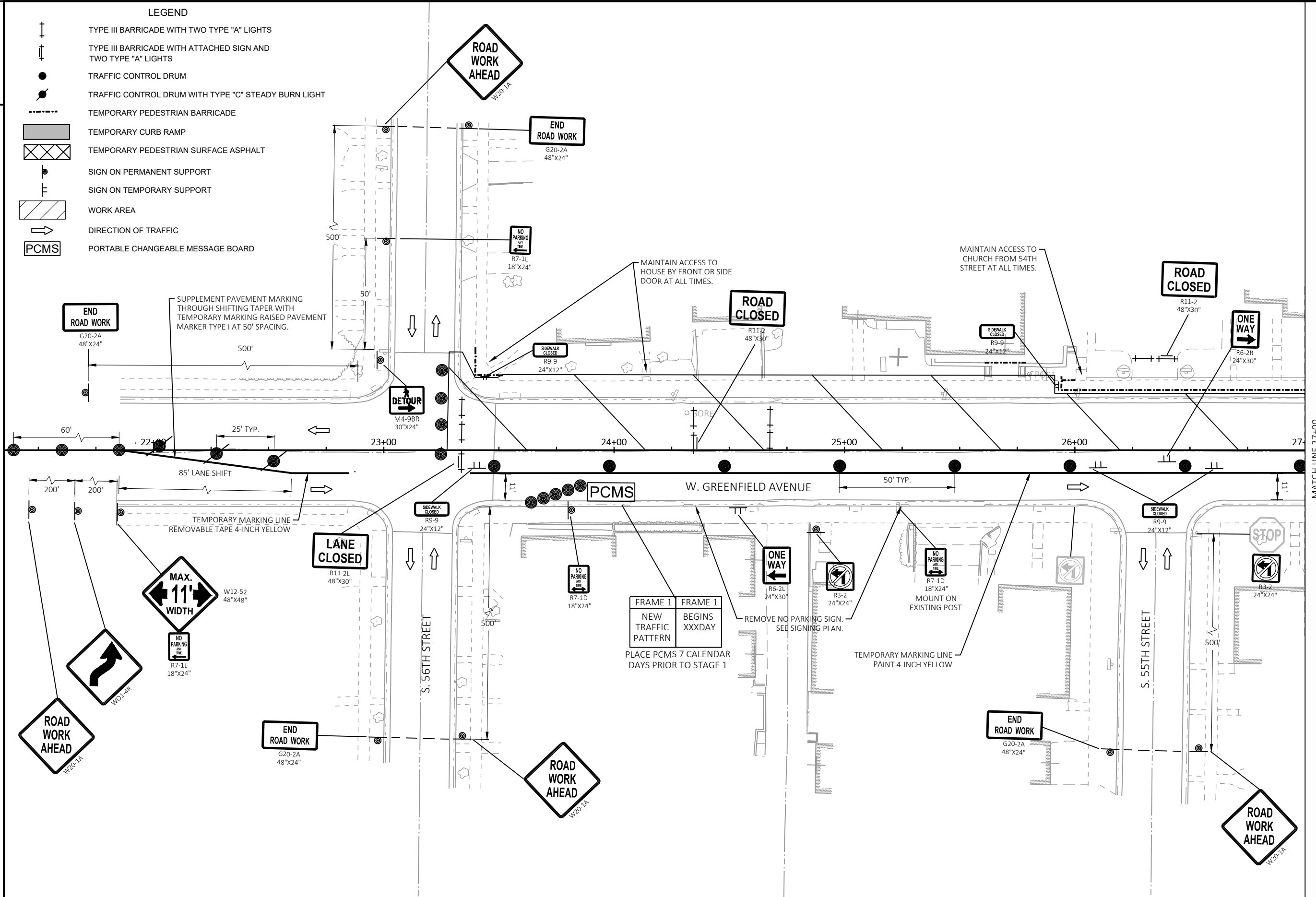











MATCH LINE 27+00

PROJECT NO: 2230-07-73	HWY: W. GREENFIELD AVENUE	COUNTY: MILWAUKEE	TRAFFIC CONTROL - STAGE 1A	SHEET	E
------------------------	---------------------------	-------------------	----------------------------	-------	----------



LEGEND

-  TYPE III BARRICADE WITH TWO TYPE "A" LIGHTS
-  TYPE III BARRICADE WITH ATTACHED SIGN AND TWO TYPE "A" LIGHTS
-  TRAFFIC CONTROL DRUM
-  TRAFFIC CONTROL DRUM WITH TYPE "C" STEADY BURN LIGHT
-  TEMPORARY PEDESTRIAN BARRICADE
-  TEMPORARY CURB RAMP
-  TEMPORARY PEDESTRIAN SURFACE ASPHALT
-  SIGN ON PERMANENT SUPPORT
-  SIGN ON TEMPORARY SUPPORT
-  WORK AREA
-  DIRECTION OF TRAFFIC
-  PORTABLE CHANGEABLE MESSAGE BOARD

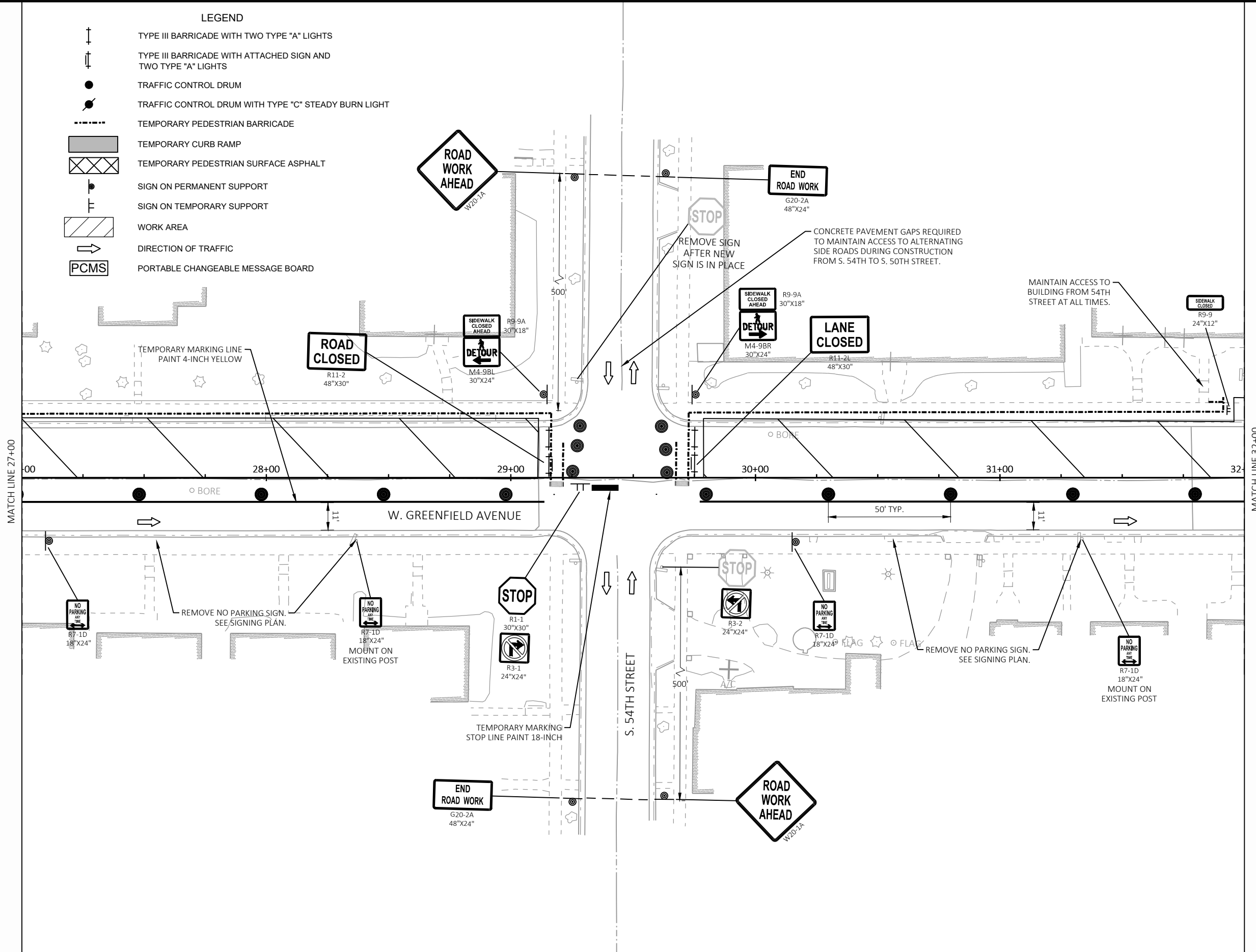

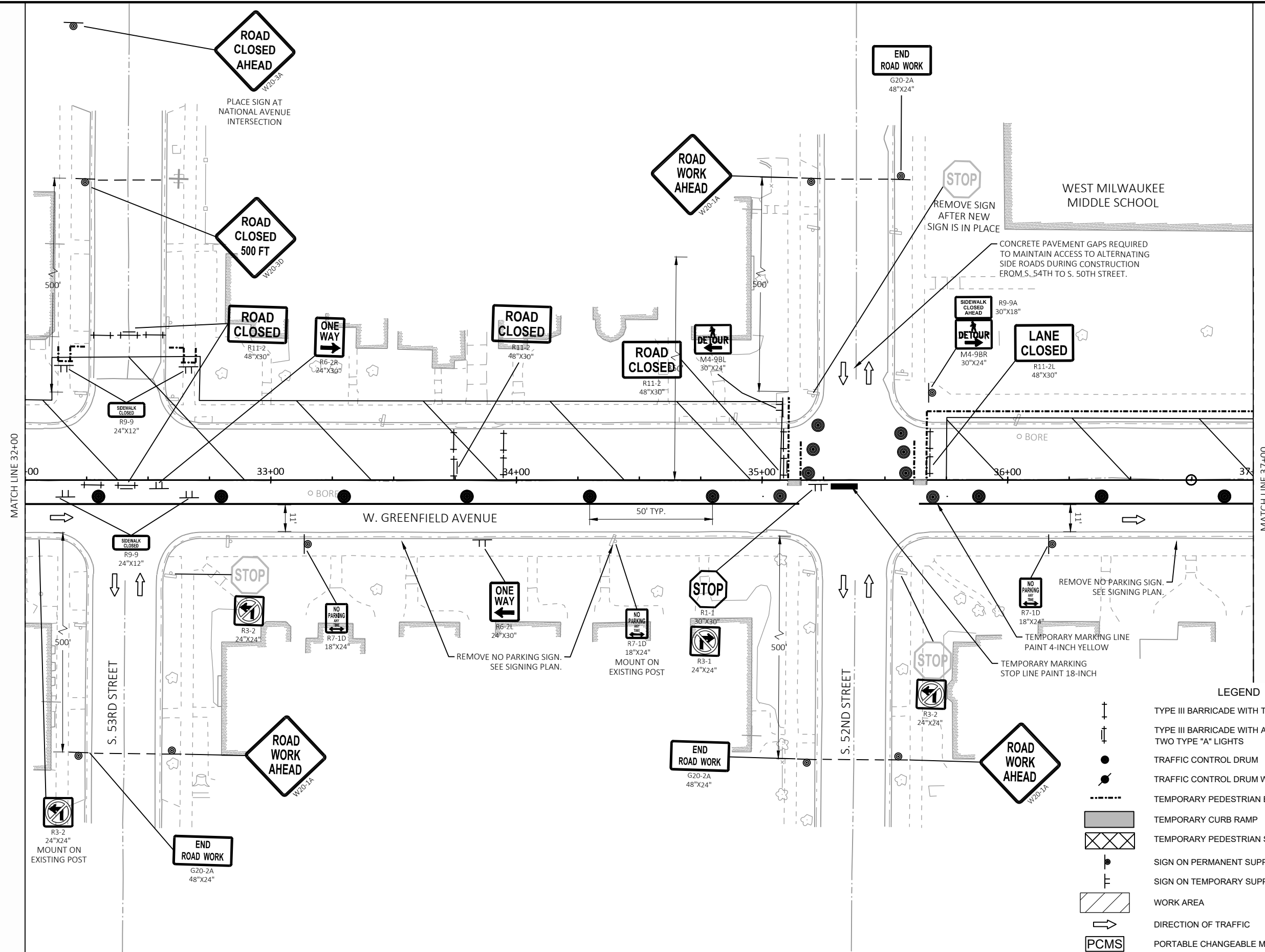

LEGEND

	TYPE III BARRICADE WITH TWO TYPE "A" LIGHTS
	TYPE III BARRICADE WITH ATTACHED SIGN AND TWO TYPE "A" LIGHTS
	TRAFFIC CONTROL DRUM
	TRAFFIC CONTROL DRUM WITH TYPE "C" STEADY BURN LIGHT
	TEMPORARY PEDESTRIAN BARRICADE
	TEMPORARY CURB RAMP
	TEMPORARY PEDESTRIAN SURFACE ASPHALT
	SIGN ON PERMANENT SUPPORT
	SIGN ON TEMPORARY SUPPORT
	WORK AREA
	DIRECTION OF TRAFFIC
	PORTABLE CHANGEABLE MESSAGE BOARD

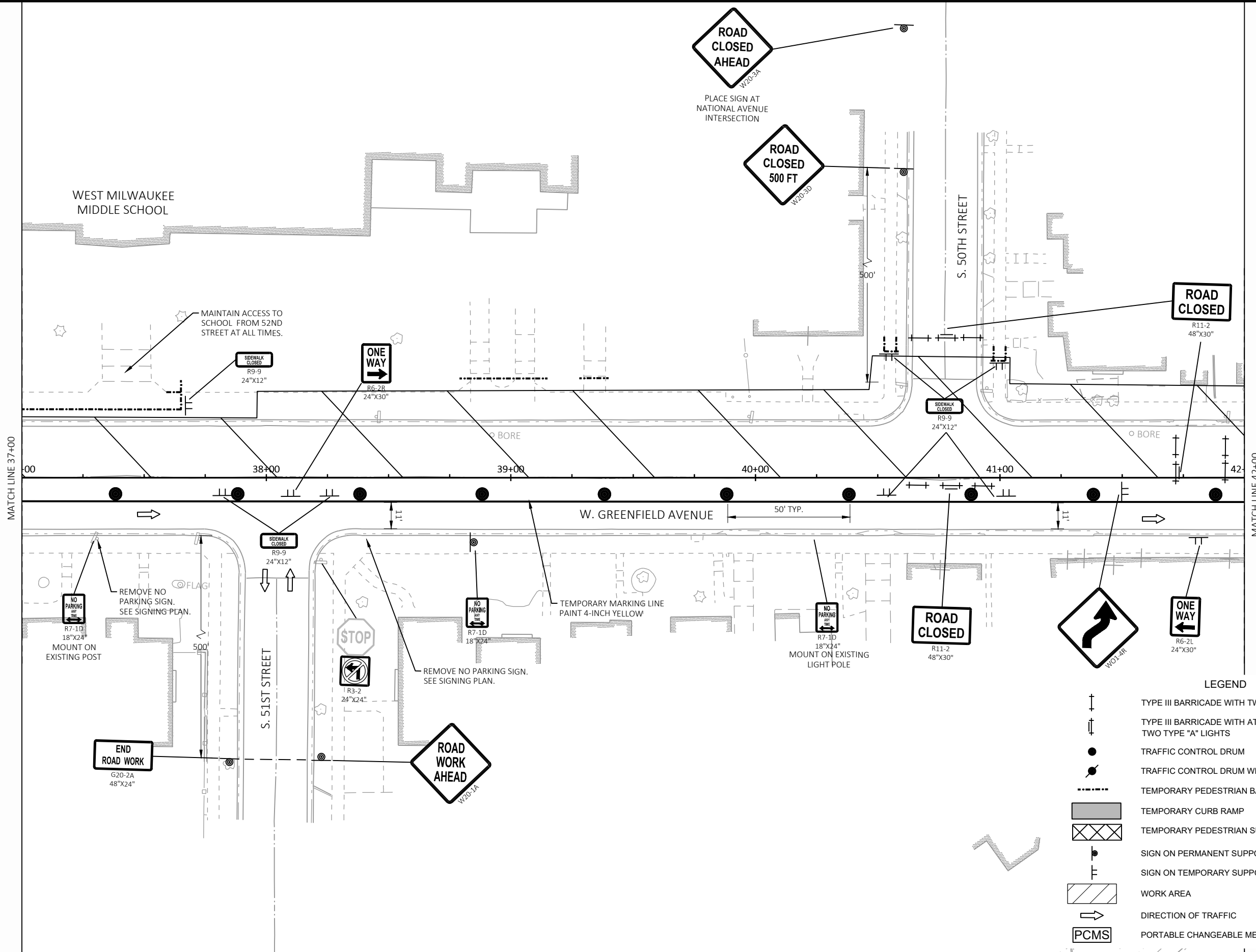

LEGEND

- TYPE III BARRICADE WITH TWO TYPE "A" LIGHTS
- TYPE III BARRICADE WITH ATTACHED SIGN AND TWO TYPE "A" LIGHTS
- TRAFFIC CONTROL DRUM
- TRAFFIC CONTROL DRUM WITH TYPE "C" STEADY BURN LIGHT
- TEMPORARY PEDESTRIAN BARRICADE
- TEMPORARY CURB RAMP
- TEMPORARY PEDESTRIAN SURFACE ASPHALT
- SIGN ON PERMANENT SUPPORT
- SIGN ON TEMPORARY SUPPORT
- WORK AREA
- DIRECTION OF TRAFFIC
- PCMS

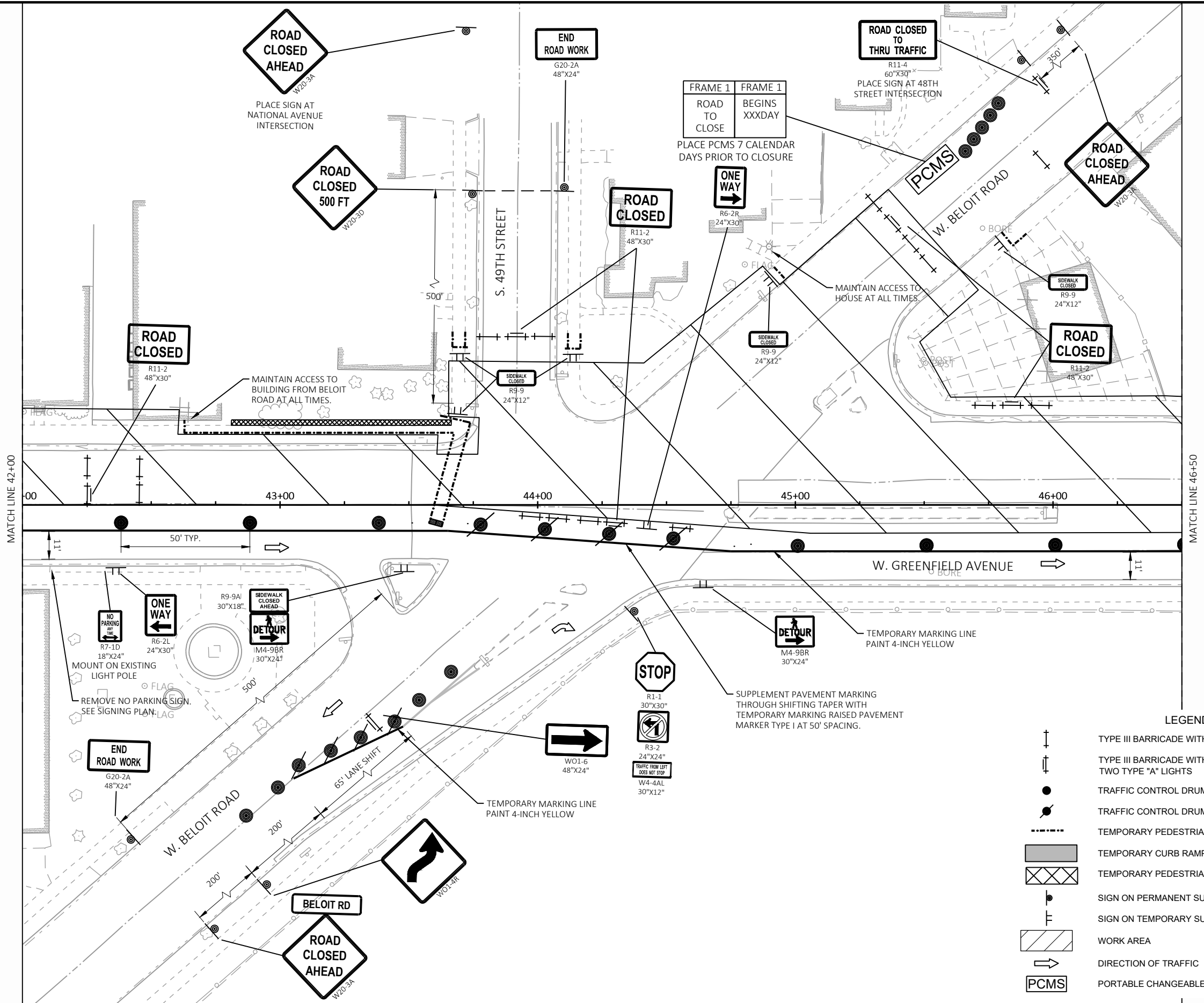

LEGEND

- TYPE III BARRICADE WITH TWO TYPE "A" LIGHTS
- TYPE III BARRICADE WITH ATTACHED SIGN AND TWO TYPE "A" LIGHTS
- TRAFFIC CONTROL DRUM
- TRAFFIC CONTROL DRUM WITH TYPE "C" STEADY BURN LIGHT
- TEMPORARY PEDESTRIAN BARRICADE
- TEMPORARY CURB RAMP
- TEMPORARY PEDESTRIAN SURFACE ASPHALT
- SIGN ON PERMANENT SUPPORT
- SIGN ON TEMPORARY SUPPORT
- WORK AREA
- DIRECTION OF TRAFFIC
- PORTABLE CHANGEABLE MESSAGE BOARD

PROJECT NO: 2230-07-73	HWY: W. GREENFIELD AVENUE	COUNTY: MILWAUKEE	TRAFFIC CONTROL - STAGE 1A	SHEET	E
------------------------	---------------------------	-------------------	----------------------------	-------	----------

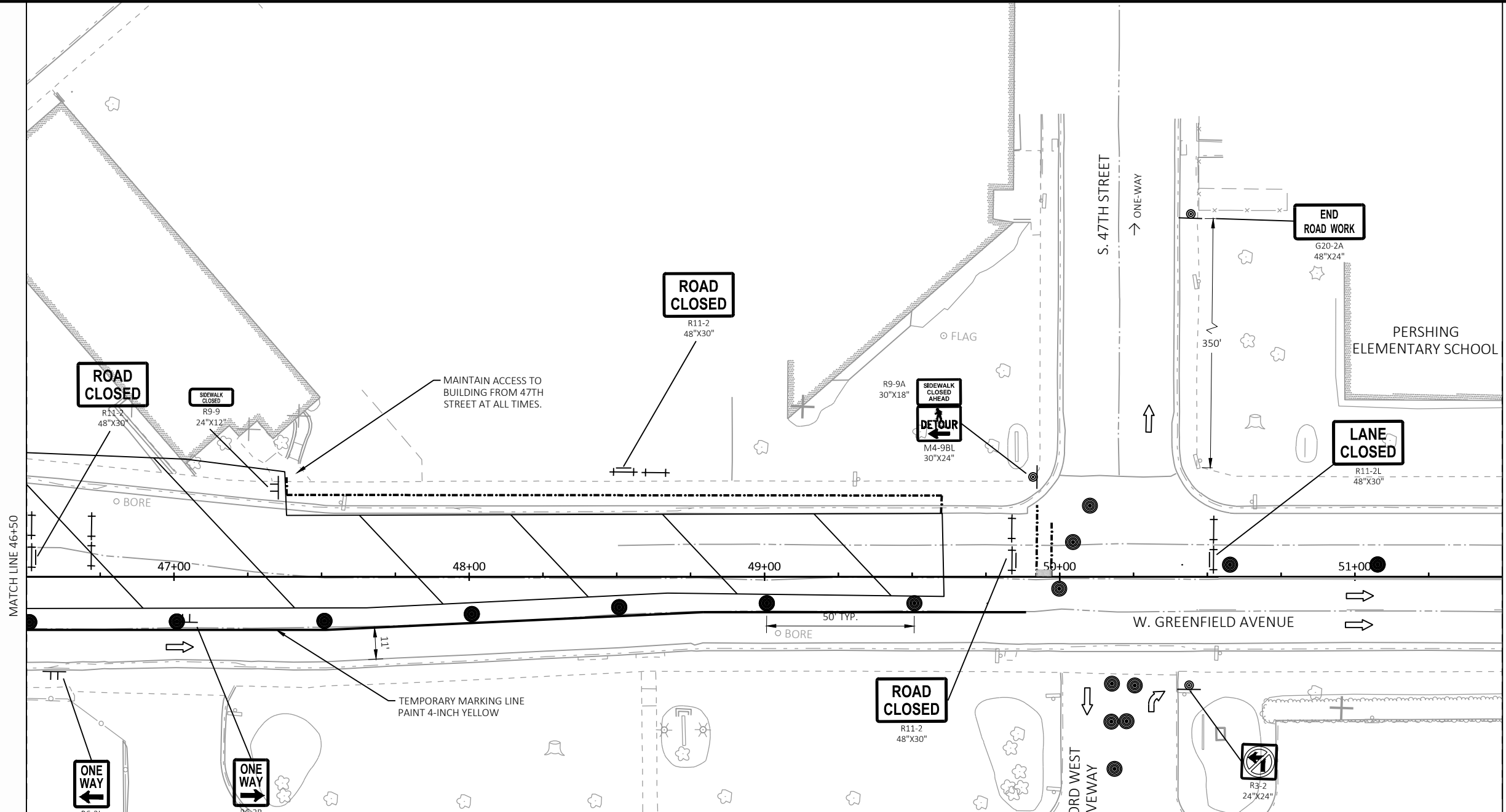

MATCH LINE 46+50

MATCH LINE 51+50

LEGEND

	TYPE III BARRICADE WITH TWO TYPE "A" LIGHTS
	TYPE III BARRICADE WITH ATTACHED SIGN AND TWO TYPE "A" LIGHTS
	TRAFFIC CONTROL DRUM
	TRAFFIC CONTROL DRUM WITH TYPE "C" STEADY BURN LIGHT
	TEMPORARY PEDESTRIAN BARRICADE
	TEMPORARY CURB RAMP
	TEMPORARY PEDESTRIAN SURFACE ASPHALT
	SIGN ON PERMANENT SUPPORT
	SIGN ON TEMPORARY SUPPORT
	WORK AREA
	DIRECTION OF TRAFFIC
	PORTABLE CHANGEABLE MESSAGE BOARD

PROJECT NO: 2230-07-73	HWY: W. GREENFIELD AVENUE	COUNTY: MILWAUKEE	TRAFFIC CONTROL - STAGE 1A	SHEET	E
------------------------	---------------------------	-------------------	----------------------------	-------	----------

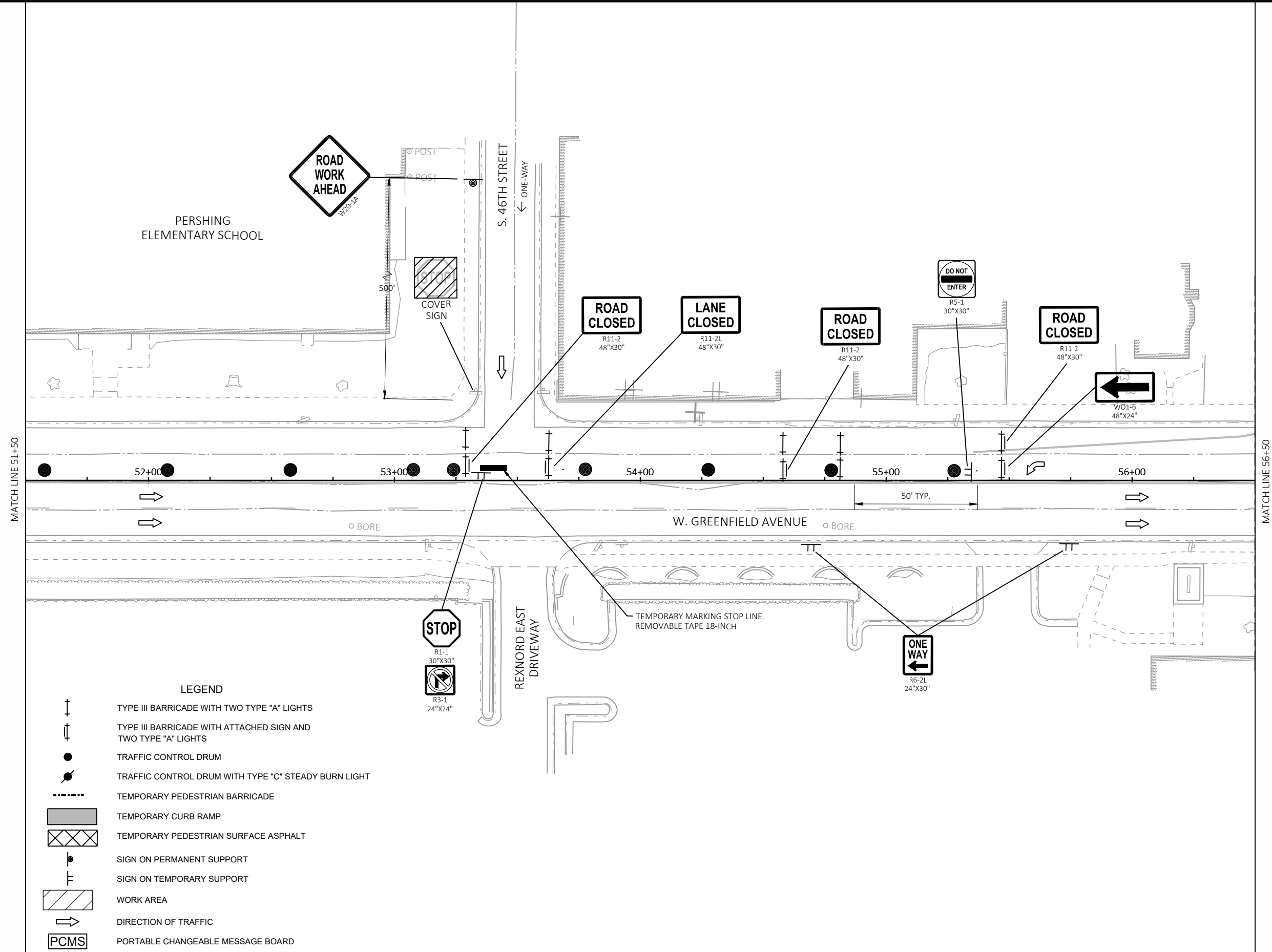

LEGEND

- TYPE III BARRICADE WITH TWO TYPE "A" LIGHTS
- TYPE III BARRICADE WITH ATTACHED SIGN AND TWO TYPE "A" LIGHTS
- TRAFFIC CONTROL DRUM
- TRAFFIC CONTROL DRUM WITH TYPE "C" STEADY BURN LIGHT
- TEMPORARY PEDESTRIAN BARRICADE
- TEMPORARY CURB RAMP
- TEMPORARY PEDESTRIAN SURFACE ASPHALT
- SIGN ON PERMANENT SUPPORT
- SIGN ON TEMPORARY SUPPORT
- WORK AREA
- DIRECTION OF TRAFFIC
- PORTABLE CHANGEABLE MESSAGE BOARD

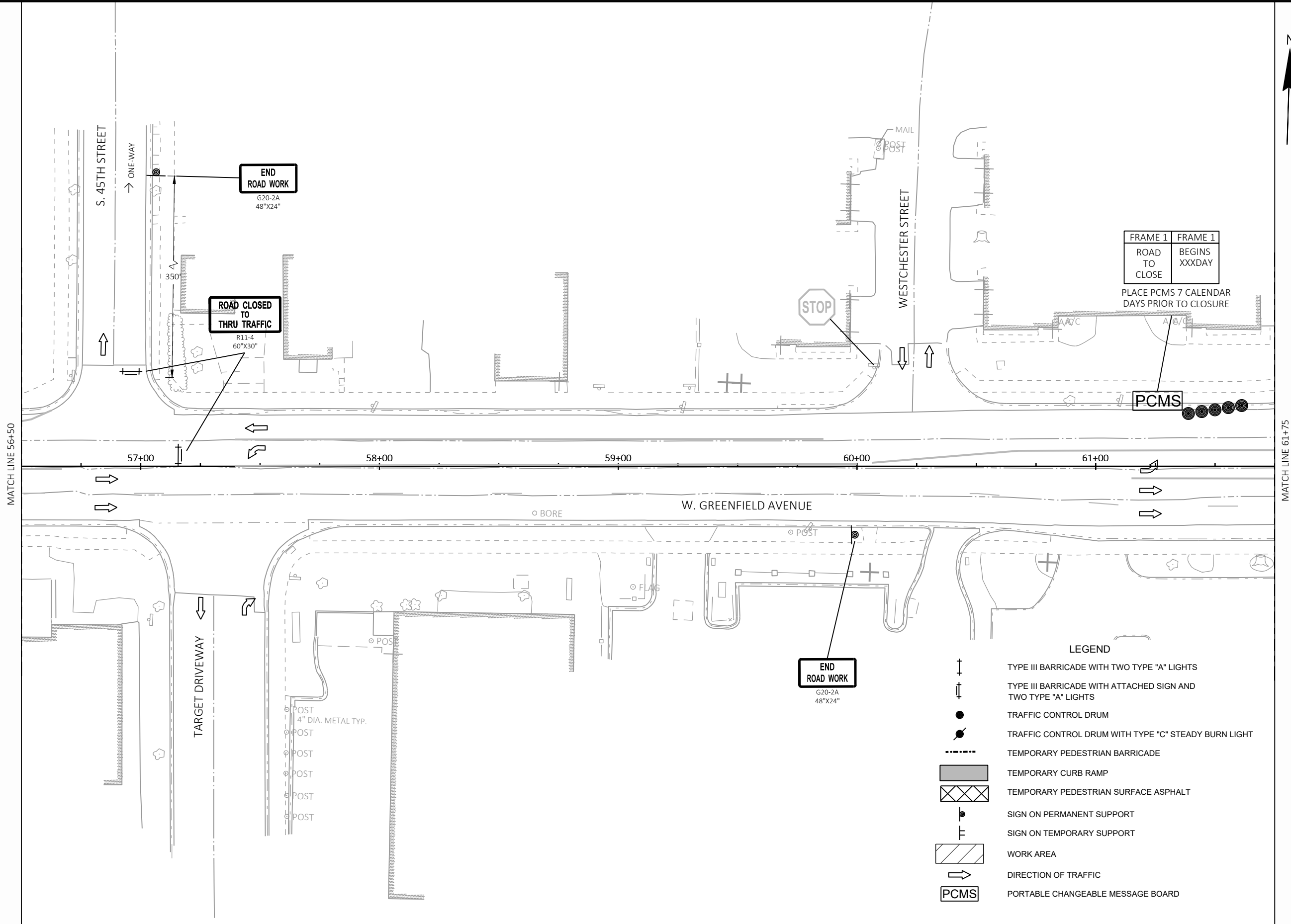

FRAME 1	FRAME 1
ROAD TO CLOSE	BEGINS XXXDAY

PLACE PCMS 7 CALENDAR DAYS PRIOR TO CLOSURE

LEGEND

- TYPE III BARRICADE WITH TWO TYPE "A" LIGHTS
- TYPE III BARRICADE WITH ATTACHED SIGN AND TWO TYPE "A" LIGHTS
- TRAFFIC CONTROL DRUM
- TRAFFIC CONTROL DRUM WITH TYPE "C" STEADY BURN LIGHT
- TEMPORARY PEDESTRIAN BARRICADE
- TEMPORARY CURB RAMP
- TEMPORARY PEDESTRIAN SURFACE ASPHALT
- SIGN ON PERMANENT SUPPORT
- SIGN ON TEMPORARY SUPPORT
- WORK AREA
- DIRECTION OF TRAFFIC
- PORTABLE CHANGEABLE MESSAGE BOARD

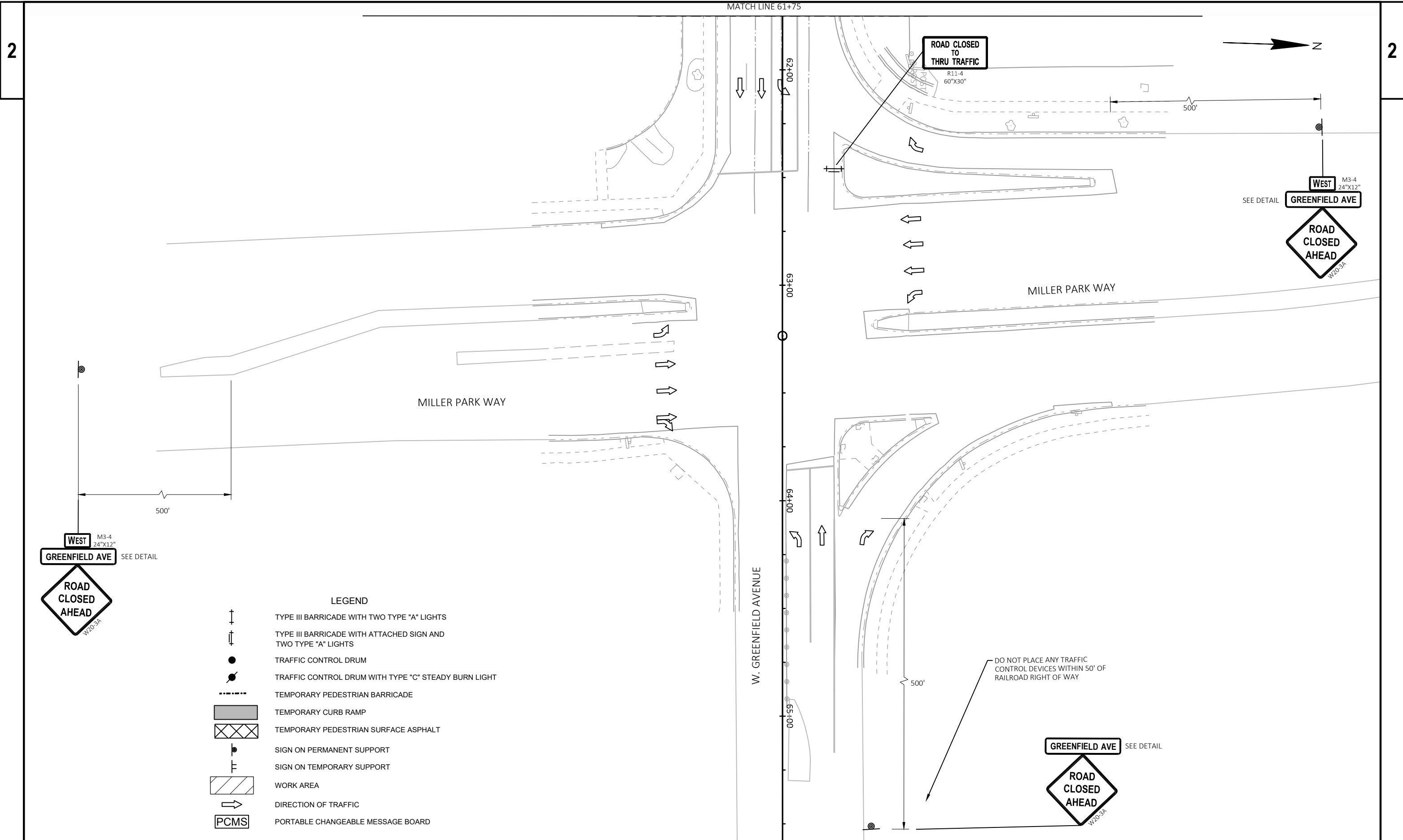

PROJECT NO: 2230-07-73

HWY: W. GREENFIELD AVENUE













COUNTY: MILWAUKEE

TRAFFIC CONTROL - STAGE 1A & 1B

SHEET

E

LEGEND





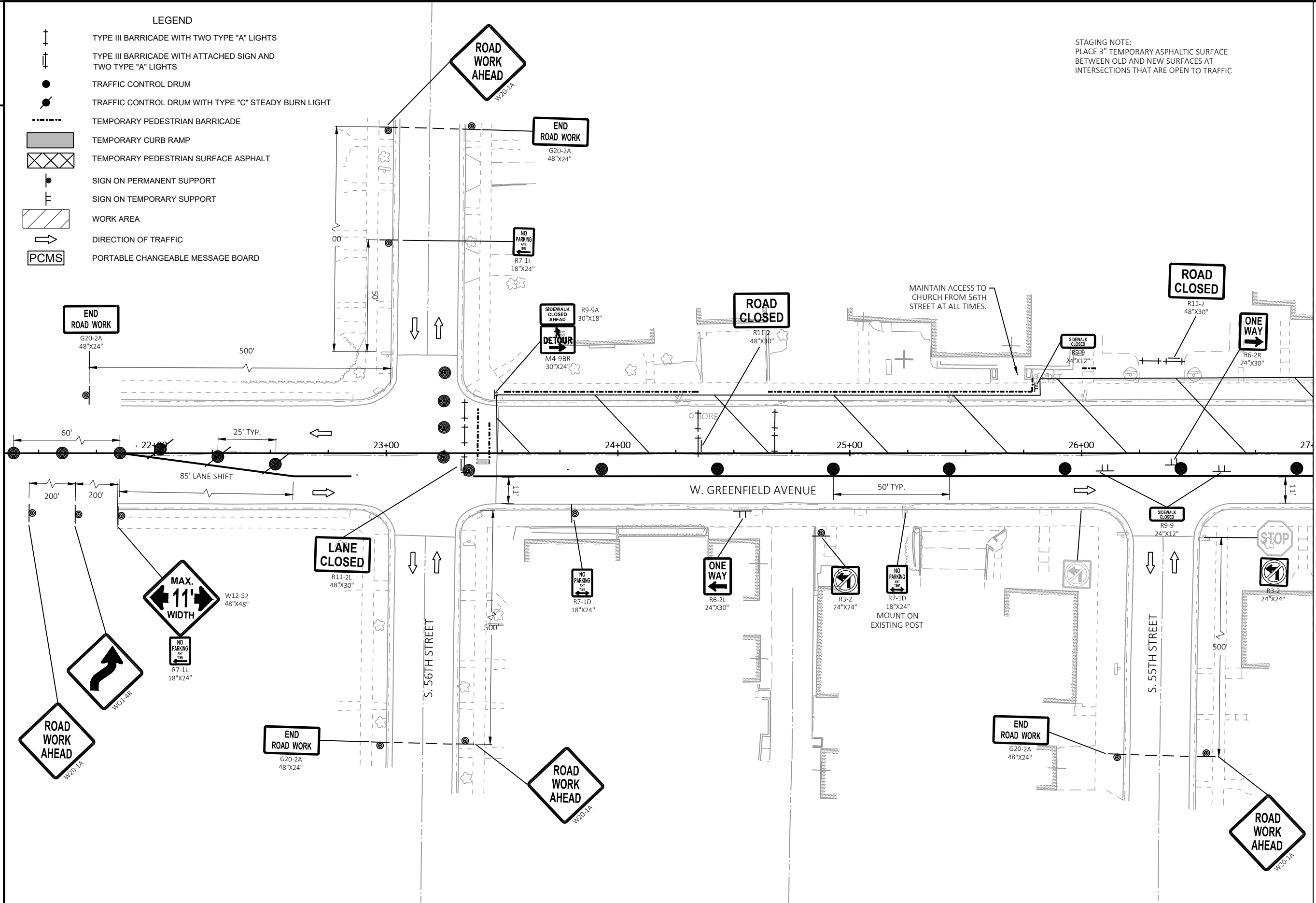







-  TYPE III BARRICADE WITH TWO TYPE "A" LIGHTS
-  TYPE III BARRICADE WITH ATTACHED SIGN AND TWO TYPE "A" LIGHTS
-  TRAFFIC CONTROL DRUM
-  TRAFFIC CONTROL DRUM WITH TYPE "C" STEADY BURN LIGHT
-  TEMPORARY PEDESTRIAN BARRICADE
-  TEMPORARY CURB RAMP
-  TEMPORARY PEDESTRIAN SURFACE ASPHALT
-  SIGN ON PERMANENT SUPPORT
-  SIGN ON TEMPORARY SUPPORT
-  WORK AREA
-  DIRECTION OF TRAFFIC
-  PORTABLE CHANGEABLE MESSAGE BOARD

STAGING NOTE:
PLACE 3" TEMPORARY ASPHALTIC SURFACE
BETWEEN OLD AND NEW SURFACES AT
INTERSECTIONS THAT ARE OPEN TO TRAFFIC



MATCH LINE 27+00

LEGEND

-  TYPE III BARRICADE WITH TWO TYPE "A" LIGHTS
-  TYPE III BARRICADE WITH ATTACHED SIGN AND TWO TYPE "A" LIGHTS
-  TRAFFIC CONTROL DRUM
-  TRAFFIC CONTROL DRUM WITH TYPE "C" STEADY BURN LIGHT
-  TEMPORARY PEDESTRIAN BARRICADE
-  TEMPORARY CURB RAMP
-  TEMPORARY PEDESTRIAN SURFACE ASPHALT
-  SIGN ON PERMANENT SUPPORT
-  SIGN ON TEMPORARY SUPPORT
-  WORK AREA
-  DIRECTION OF TRAFFIC
-  PORTABLE CHANGEABLE MESSAGE BOARD

STAGING NOTE:
PLACE 3" TEMPORARY ASPHALTIC SURFACE
BETWEEN OLD AND NEW SURFACES AT
INTERSECTIONS THAT ARE OPEN TO TRAFFIC

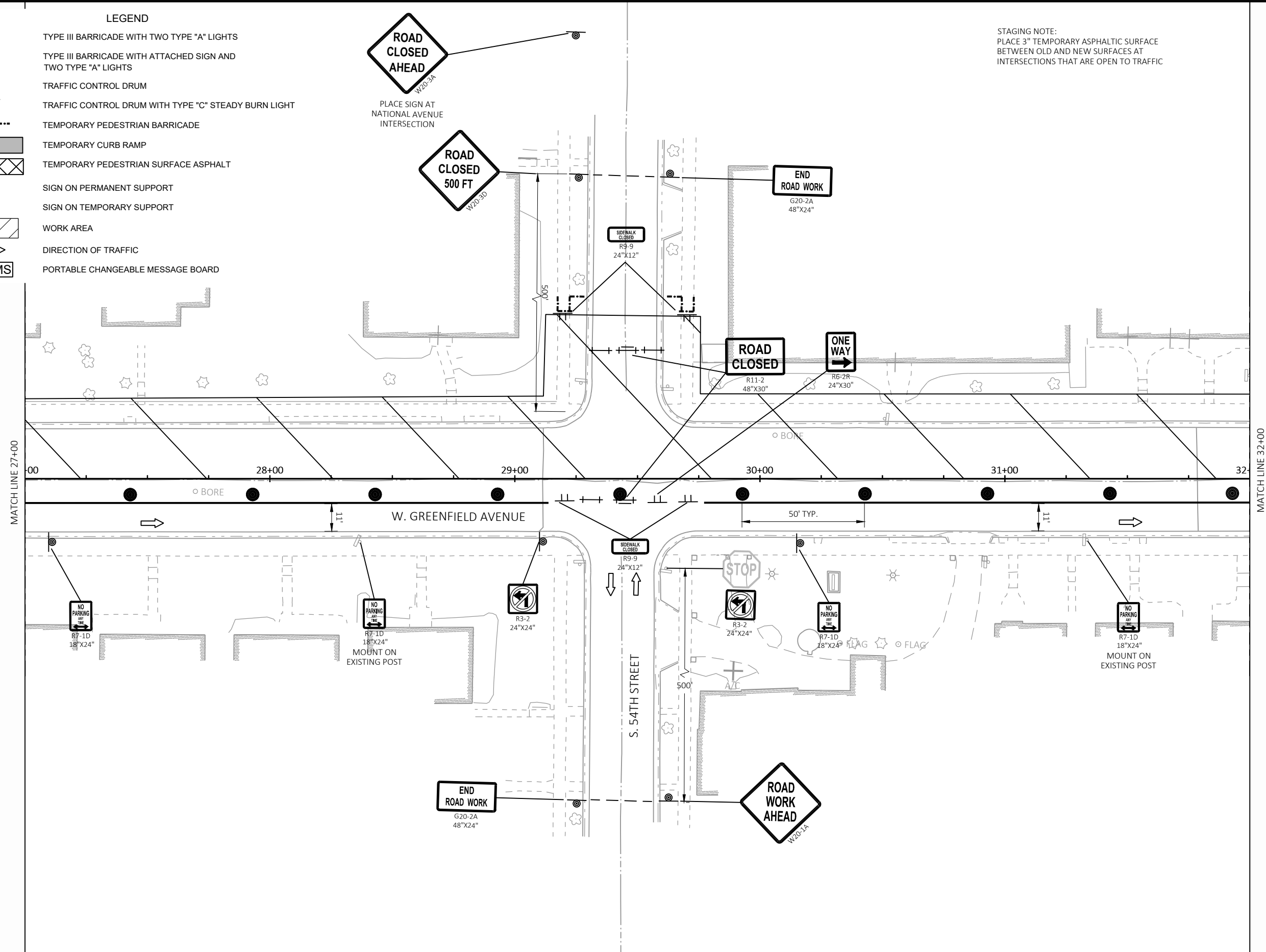

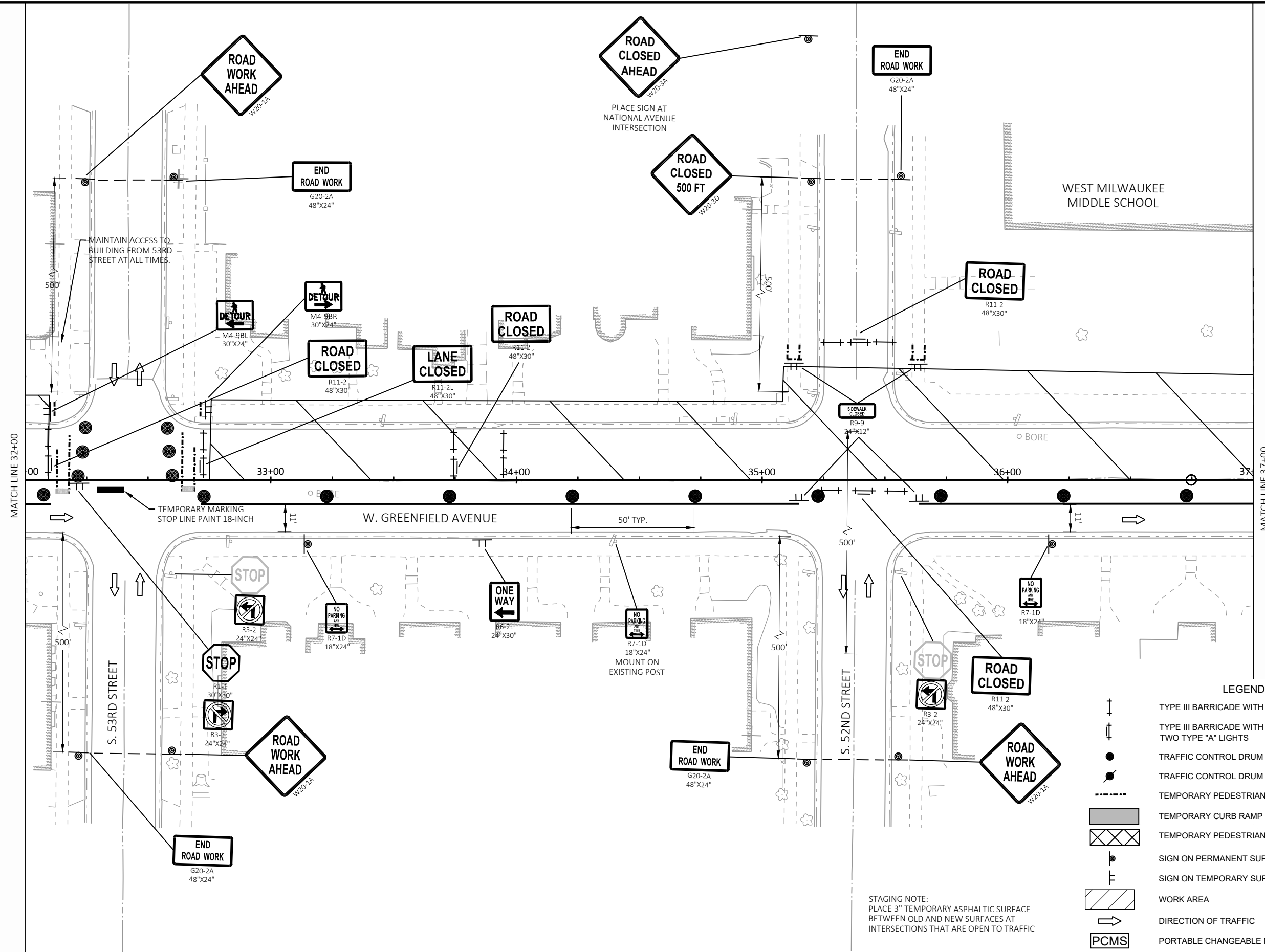

WEST MILWAUKEE MIDDLE SCHOOL

MAINTAIN ACCESS TO BUILDING FROM 53RD STREET AT ALL TIMES.

TEMPORARY MARKING STOP LINE PAINT 18-INCH

W. GREENFIELD AVENUE

50' TYP.

S. 53RD STREET

S. 52ND STREET

LEGEND

- TYPE III BARRICADE WITH TWO TYPE "A" LIGHTS
- TYPE III BARRICADE WITH ATTACHED SIGN AND TWO TYPE "A" LIGHTS
- TRAFFIC CONTROL DRUM
- TRAFFIC CONTROL DRUM WITH TYPE "C" STEADY BURN LIGHT
- TEMPORARY PEDESTRIAN BARRICADE
- TEMPORARY CURB RAMP
- TEMPORARY PEDESTRIAN SURFACE ASPHALT
- SIGN ON PERMANENT SUPPORT
- SIGN ON TEMPORARY SUPPORT
- WORK AREA
- DIRECTION OF TRAFFIC
- PORTABLE CHANGEABLE MESSAGE BOARD

STAGING NOTE:
PLACE 3" TEMPORARY ASPHALTIC SURFACE BETWEEN OLD AND NEW SURFACES AT INTERSECTIONS THAT ARE OPEN TO TRAFFIC

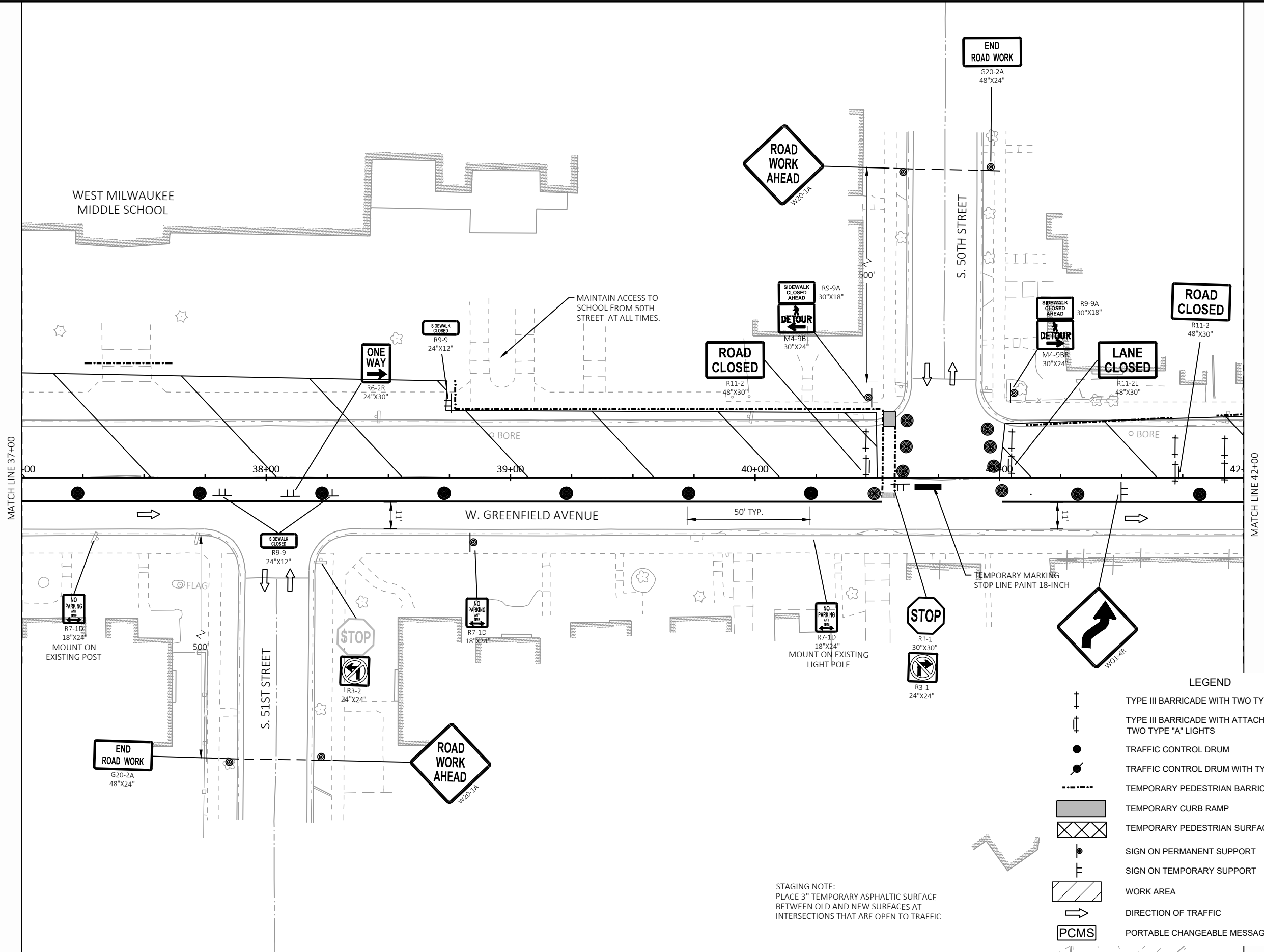

LEGEND

- TYPE III BARRICADE WITH TWO TYPE "A" LIGHTS
- TYPE III BARRICADE WITH ATTACHED SIGN AND TWO TYPE "A" LIGHTS
- TRAFFIC CONTROL DRUM
- TRAFFIC CONTROL DRUM WITH TYPE "C" STEADY BURN LIGHT
- TEMPORARY PEDESTRIAN BARRICADE
- TEMPORARY CURB RAMP
- TEMPORARY PEDESTRIAN SURFACE ASPHALT
- SIGN ON PERMANENT SUPPORT
- SIGN ON TEMPORARY SUPPORT
- WORK AREA
- DIRECTION OF TRAFFIC
- PCMS

STAGING NOTE:
PLACE 3" TEMPORARY ASPHALTIC SURFACE
BETWEEN OLD AND NEW SURFACES AT
INTERSECTIONS THAT ARE OPEN TO TRAFFIC

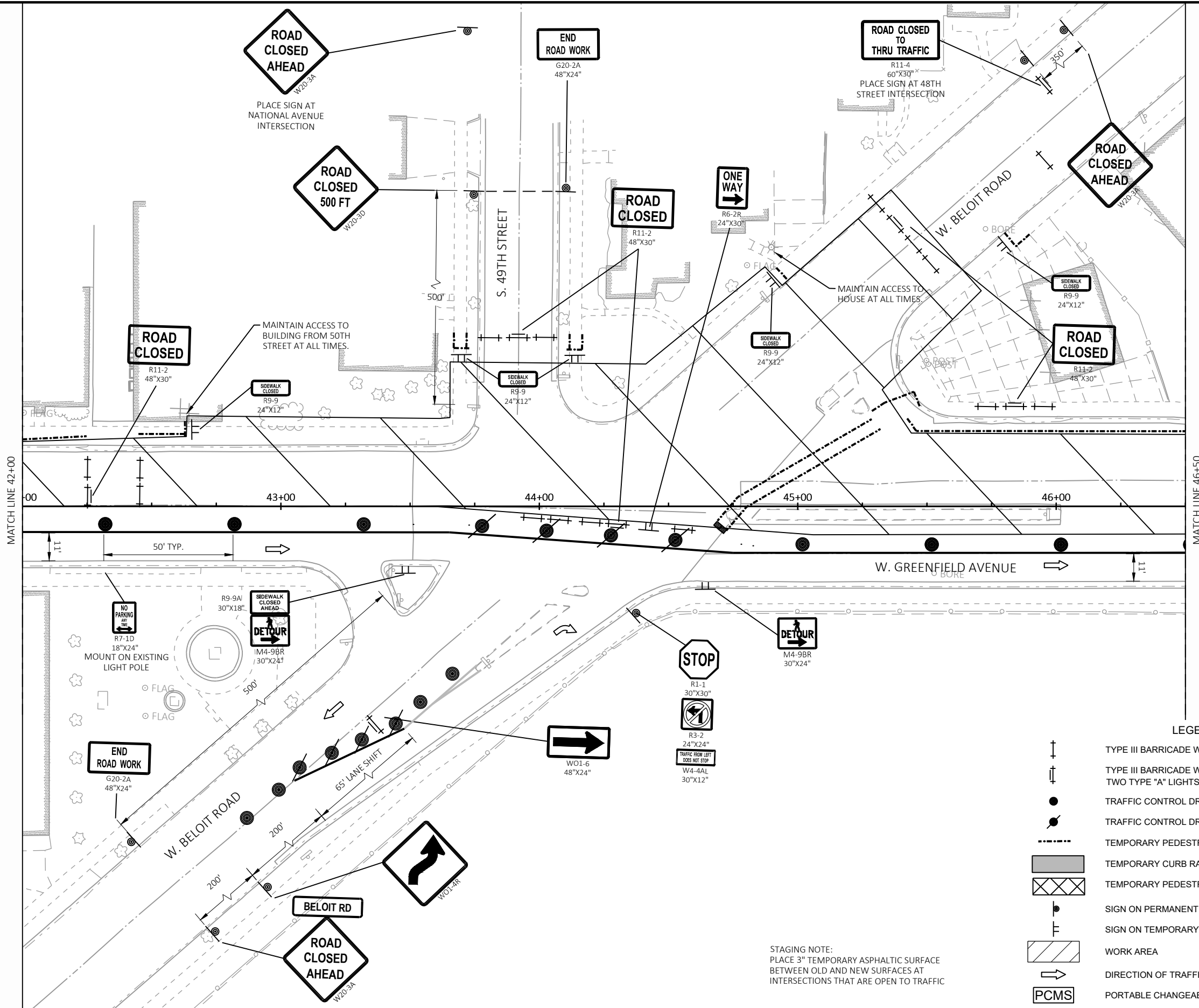

LEGEND

- TYPE III BARRICADE WITH TWO TYPE "A" LIGHTS
- TYPE III BARRICADE WITH ATTACHED SIGN AND TWO TYPE "A" LIGHTS
- TRAFFIC CONTROL DRUM
- TRAFFIC CONTROL DRUM WITH TYPE "C" STEADY BURN LIGHT
- TEMPORARY PEDESTRIAN BARRICADE
- TEMPORARY CURB RAMP
- TEMPORARY PEDESTRIAN SURFACE ASPHALT
- SIGN ON PERMANENT SUPPORT
- SIGN ON TEMPORARY SUPPORT
- WORK AREA
- DIRECTION OF TRAFFIC
- PORTABLE CHANGEABLE MESSAGE BOARD

STAGING NOTE:
 PLACE 3" TEMPORARY ASPHALTIC SURFACE
 BETWEEN OLD AND NEW SURFACES AT
 INTERSECTIONS THAT ARE OPEN TO TRAFFIC

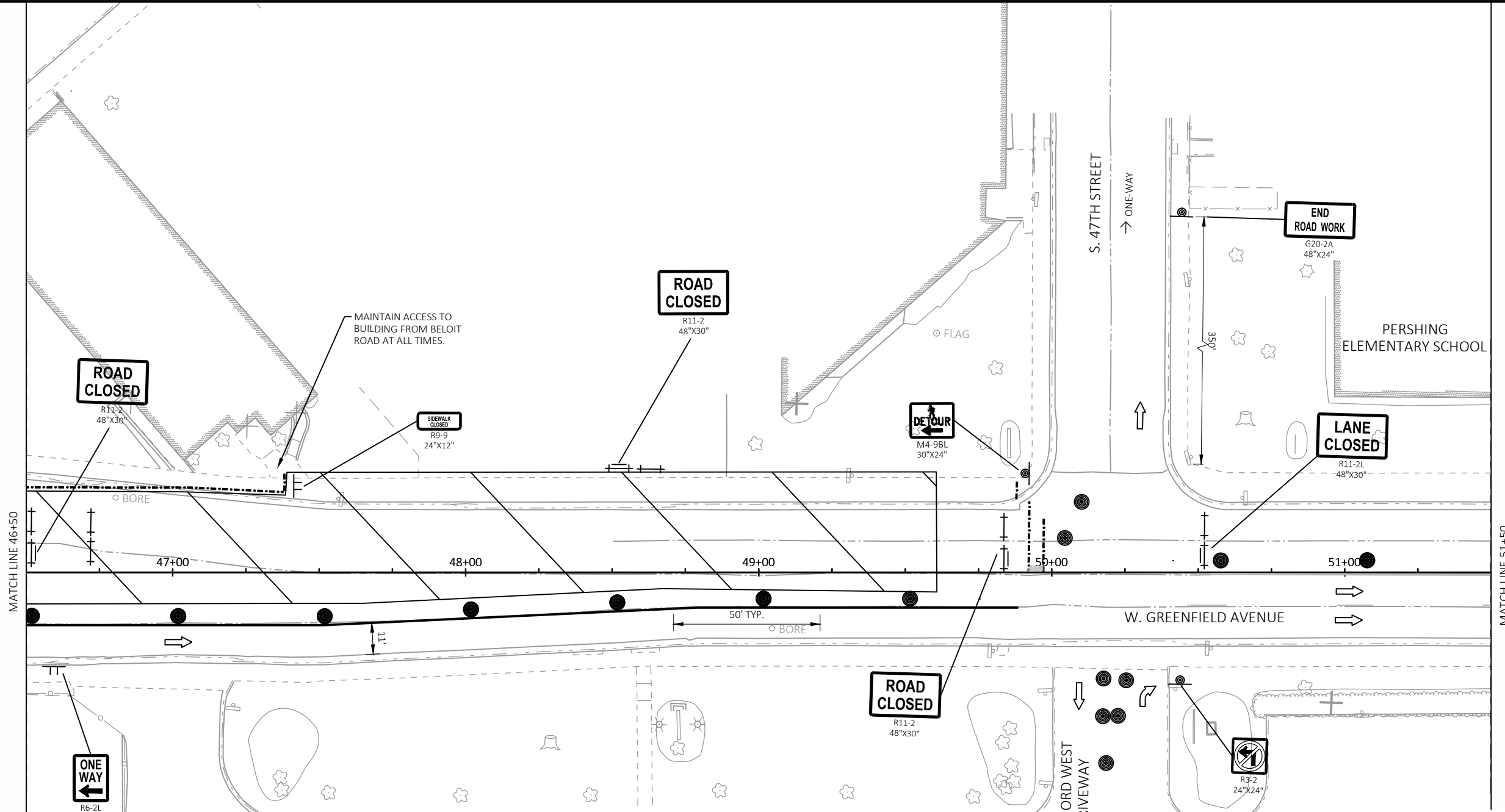

LEGEND

	TYPE III BARRICADE WITH TWO TYPE "A" LIGHTS
	TYPE III BARRICADE WITH ATTACHED SIGN AND TWO TYPE "A" LIGHTS
	TRAFFIC CONTROL DRUM
	TRAFFIC CONTROL DRUM WITH TYPE "C" STEADY BURN LIGHT
	TEMPORARY PEDESTRIAN BARRICADE
	TEMPORARY CURB RAMP
	TEMPORARY PEDESTRIAN SURFACE ASPHALT
	SIGN ON PERMANENT SUPPORT
	SIGN ON TEMPORARY SUPPORT
	WORK AREA
	DIRECTION OF TRAFFIC
	PORTABLE CHANGEABLE MESSAGE BOARD

LEGEND

- TYPE III BARRICADE WITH TWO TYPE "A" LIGHTS
- TYPE III BARRICADE WITH ATTACHED SIGN AND TWO TYPE "A" LIGHTS
- TRAFFIC CONTROL DRUM
- TRAFFIC CONTROL DRUM WITH TYPE "C" STEADY BURN LIGHT
- TEMPORARY PEDESTRIAN BARRICADE
- TEMPORARY CURB RAMP
- TEMPORARY PEDESTRIAN SURFACE PLATE
- SIGN ON PERMANENT SUPPORT
- SIGN ON TEMPORARY SUPPORT
- WORK AREA
- DIRECTION OF TRAFFIC
- PORTABLE CHANGEABLE MESSAGE BOARD





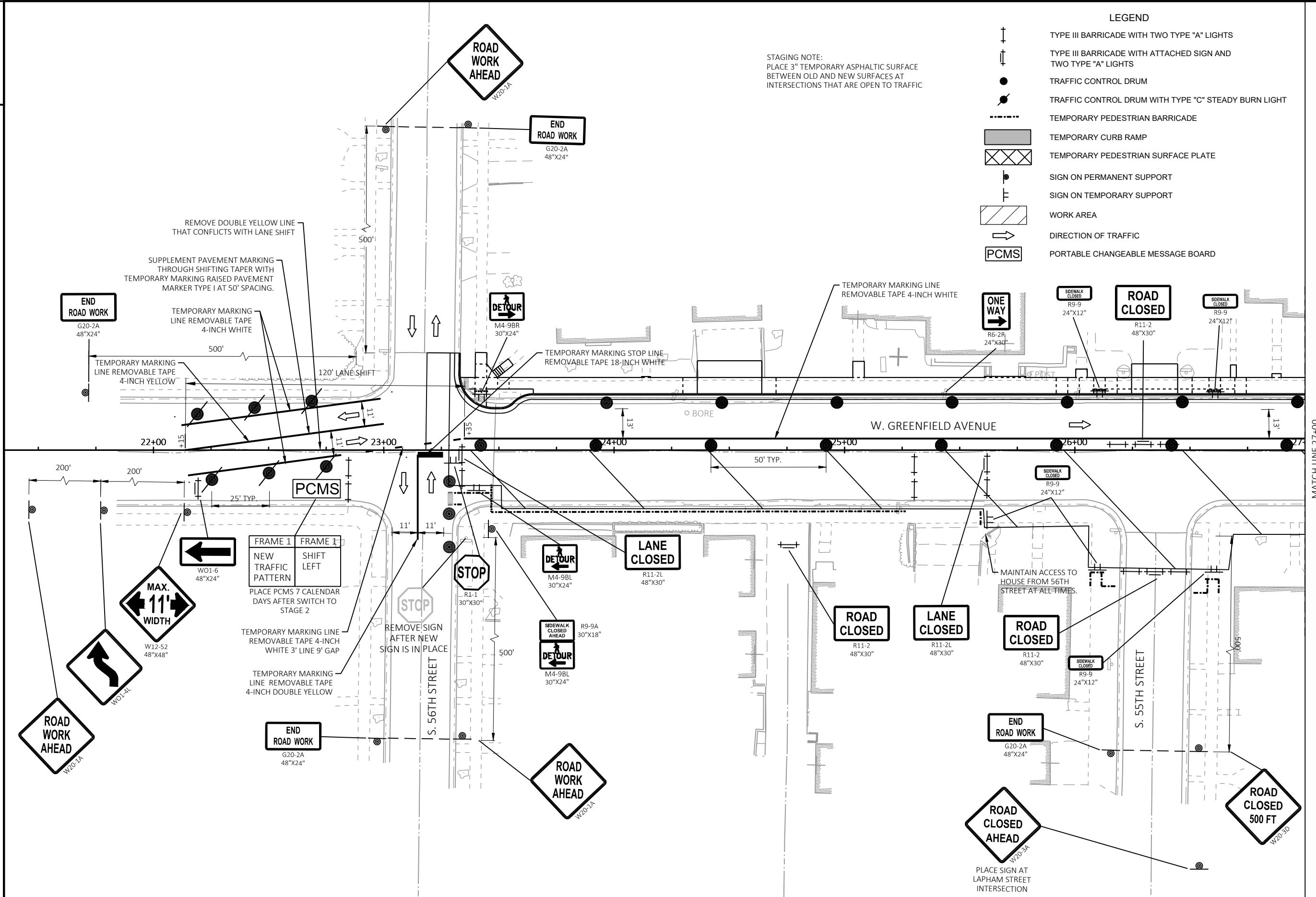









STAGING NOTE:
 PLACE 3" TEMPORARY ASPHALTIC SURFACE
 BETWEEN OLD AND NEW SURFACES AT
 INTERSECTIONS THAT ARE OPEN TO TRAFFIC



PROJECT NO: 2230-07-73	HWY: W. GREENFIELD AVENUE	COUNTY: MILWAUKEE	TRAFFIC CONTROL - STAGE 2A	SHEET E
------------------------	---------------------------	-------------------	----------------------------	---------



LEGEND

-  TYPE III BARRICADE WITH TWO TYPE "A" LIGHTS
-  TYPE III BARRICADE WITH ATTACHED SIGN AND TWO TYPE "A" LIGHTS
-  TRAFFIC CONTROL DRUM
-  TRAFFIC CONTROL DRUM WITH TYPE "C" STEADY BURN LIGHT
-  TEMPORARY PEDESTRIAN BARRICADE
-  TEMPORARY CURB RAMP
-  TEMPORARY PEDESTRIAN SURFACE PLATE
-  SIGN ON PERMANENT SUPPORT
-  SIGN ON TEMPORARY SUPPORT
-  WORK AREA
-  DIRECTION OF TRAFFIC
-  PORTABLE CHANGEABLE MESSAGE BOARD

STAGING NOTE:
PLACE 3" TEMPORARY ASPHALTIC SURFACE
BETWEEN OLD AND NEW SURFACES AT
INTERSECTIONS THAT ARE OPEN TO TRAFFIC

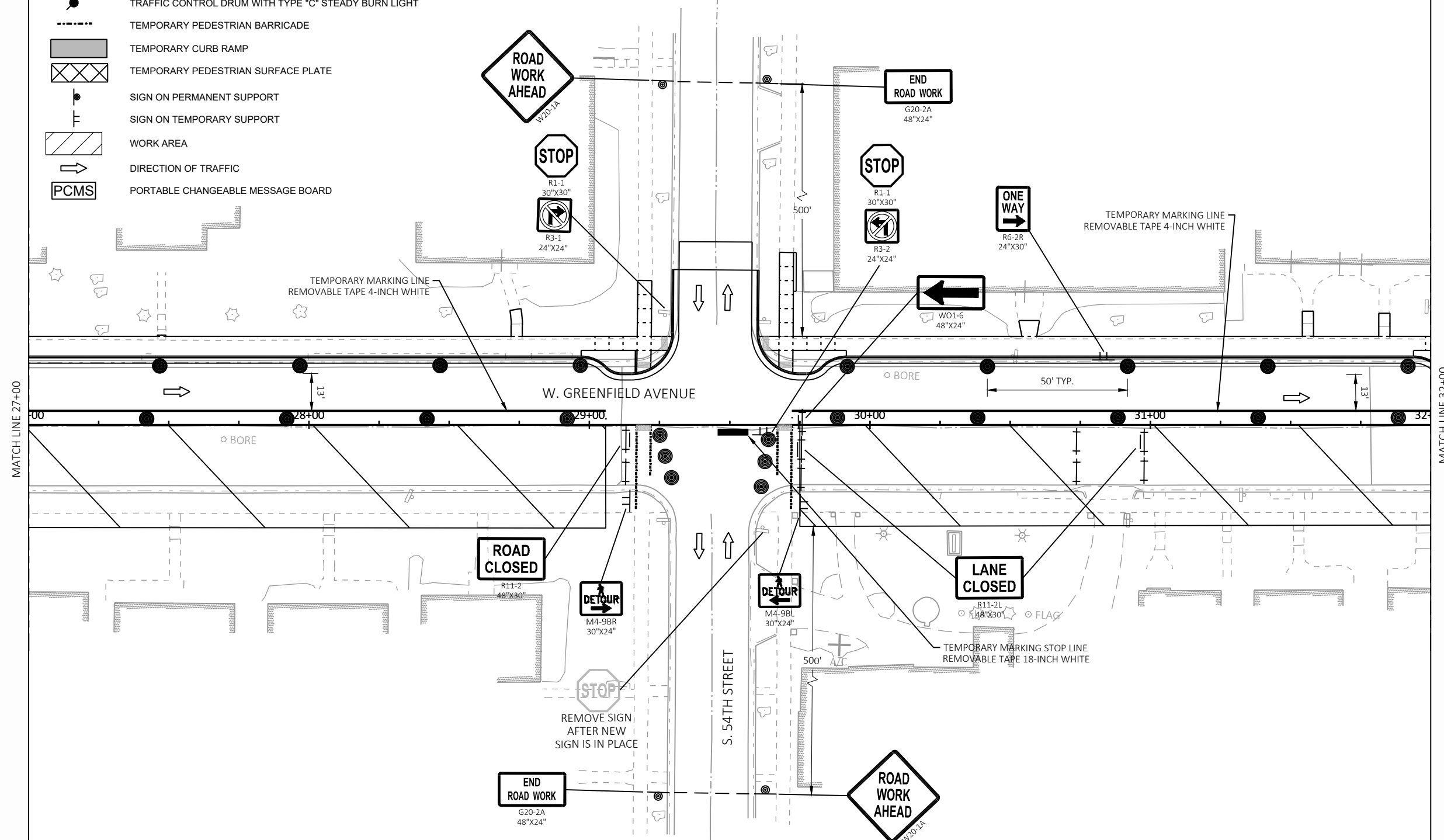

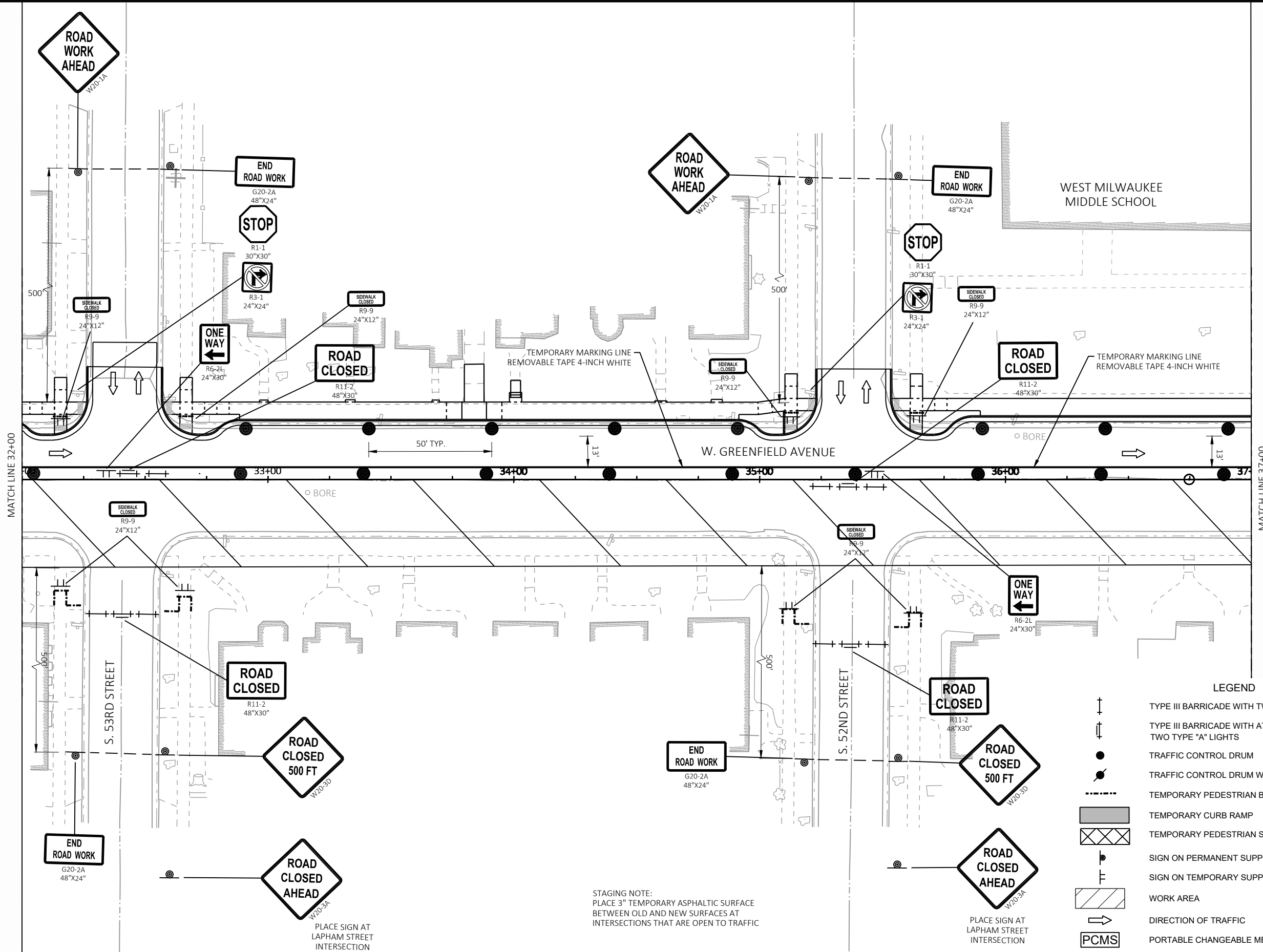

STAGING NOTE:
 PLACE 3" TEMPORARY ASPHALTIC SURFACE
 BETWEEN OLD AND NEW SURFACES AT
 INTERSECTIONS THAT ARE OPEN TO TRAFFIC

LEGEND

- TYPE III BARRICADE WITH TWO TYPE "A" LIGHTS
- TYPE III BARRICADE WITH ATTACHED SIGN AND TWO TYPE "A" LIGHTS
- TRAFFIC CONTROL DRUM
- TRAFFIC CONTROL DRUM WITH TYPE "C" STEADY BURN LIGHT
- TEMPORARY PEDESTRIAN BARRICADE
- TEMPORARY CURB RAMP
- TEMPORARY PEDESTRIAN SURFACE PLATE
- SIGN ON PERMANENT SUPPORT
- SIGN ON TEMPORARY SUPPORT
- WORK AREA
- DIRECTION OF TRAFFIC
- PCMS

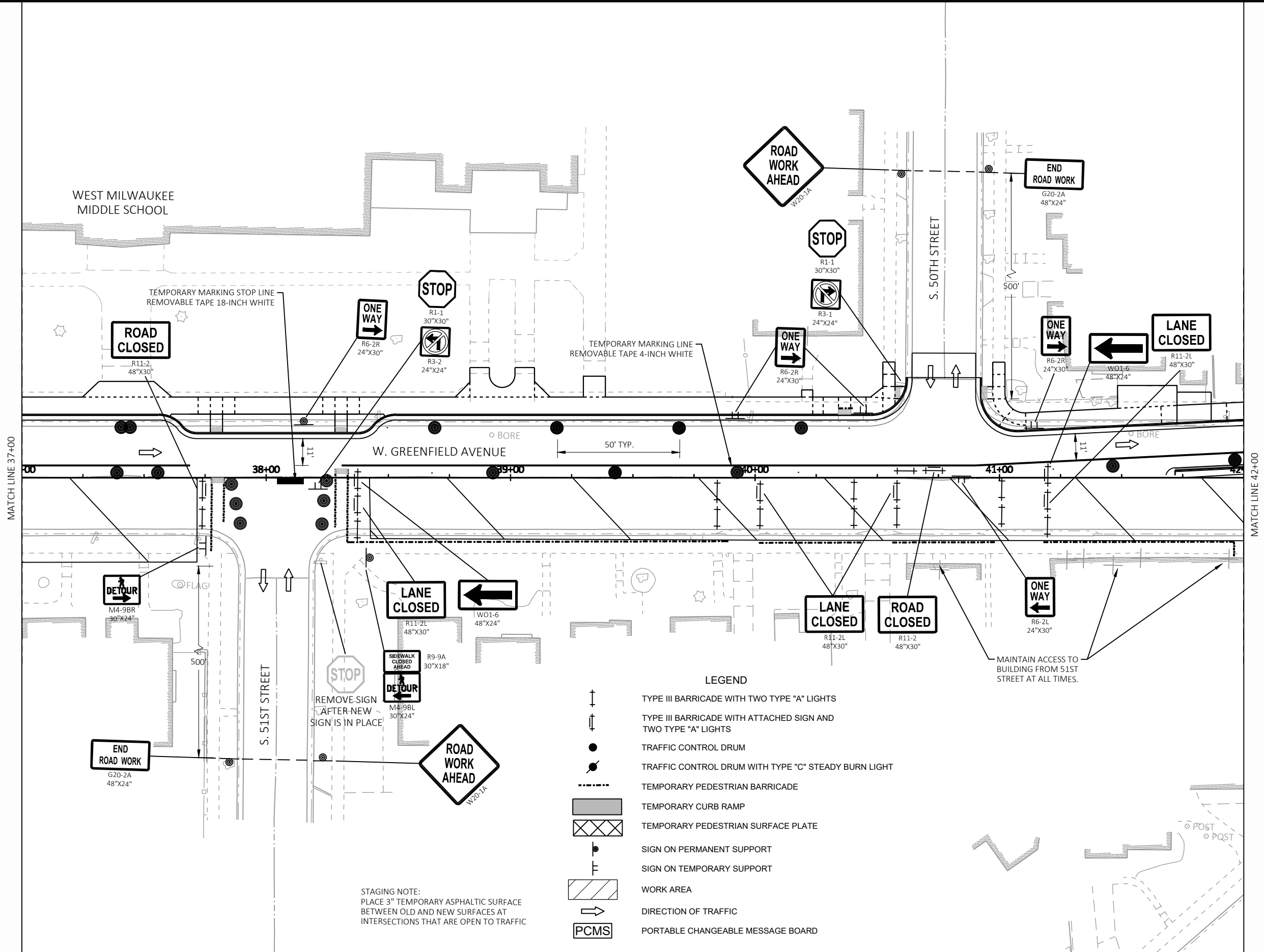

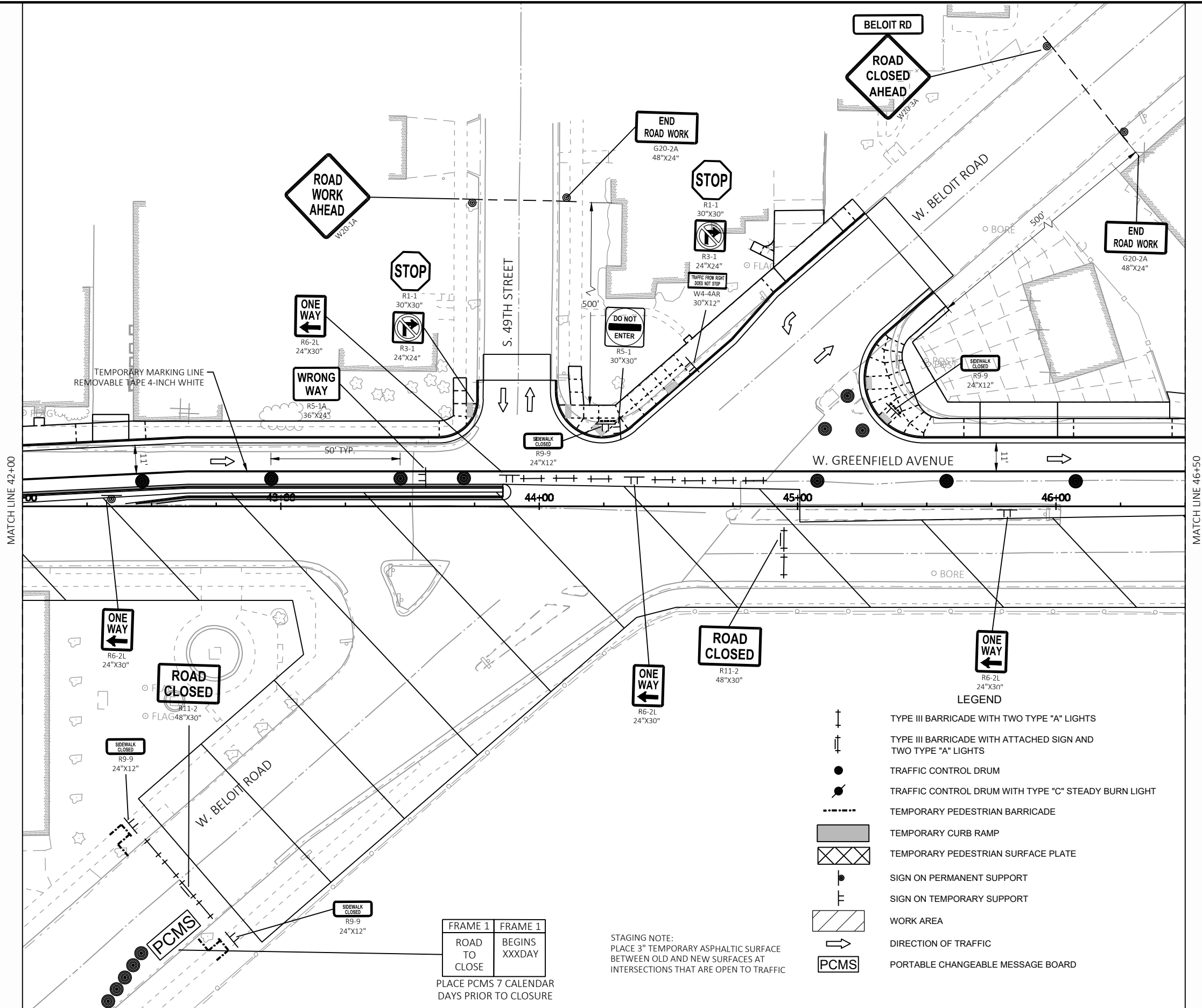

TEMPORARY MARKING LINE
REMOVABLE TAPE 4-INCH WHITE

MATCH LINE 42+00

MATCH LINE 46+50

FRAME 1	FRAME 1
ROAD TO CLOSE	BEGINS XXXDAY

PLACE PCMS 7 CALENDAR DAYS PRIOR TO CLOSURE

STAGING NOTE:
PLACE 3" TEMPORARY ASPHALTIC SURFACE BETWEEN OLD AND NEW SURFACES AT INTERSECTIONS THAT ARE OPEN TO TRAFFIC

- LEGEND**
- TYPE III BARRICADE WITH TWO TYPE "A" LIGHTS
 - TYPE III BARRICADE WITH ATTACHED SIGN AND TWO TYPE "A" LIGHTS
 - TRAFFIC CONTROL DRUM
 - TRAFFIC CONTROL DRUM WITH TYPE "C" STEADY BURN LIGHT
 - TEMPORARY PEDESTRIAN BARRICADE
 - TEMPORARY CURB RAMP
 - TEMPORARY PEDESTRIAN SURFACE PLATE
 - SIGN ON PERMANENT SUPPORT
 - SIGN ON TEMPORARY SUPPORT
 - WORK AREA
 - DIRECTION OF TRAFFIC
 - PORTABLE CHANGEABLE MESSAGE BOARD

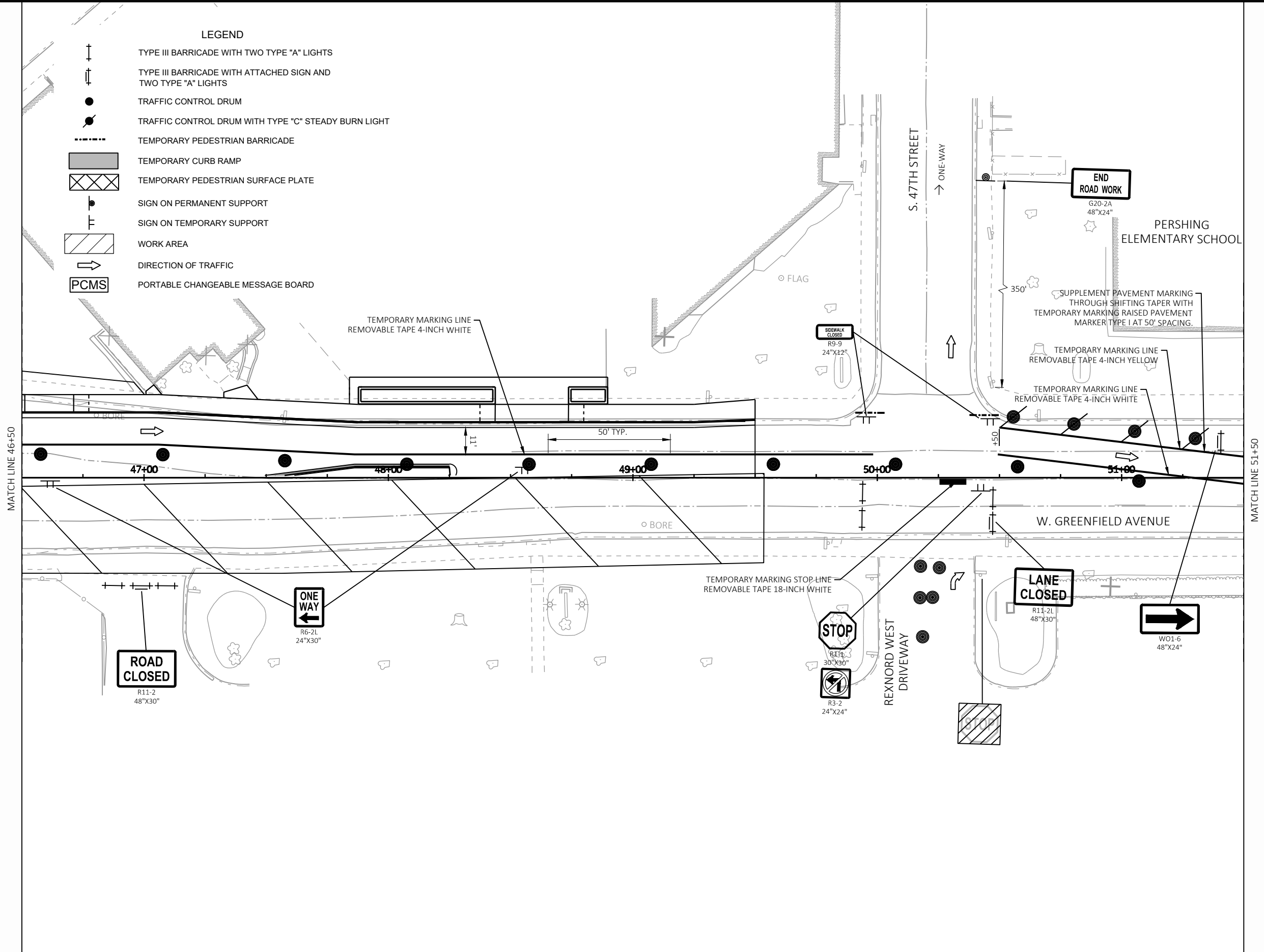

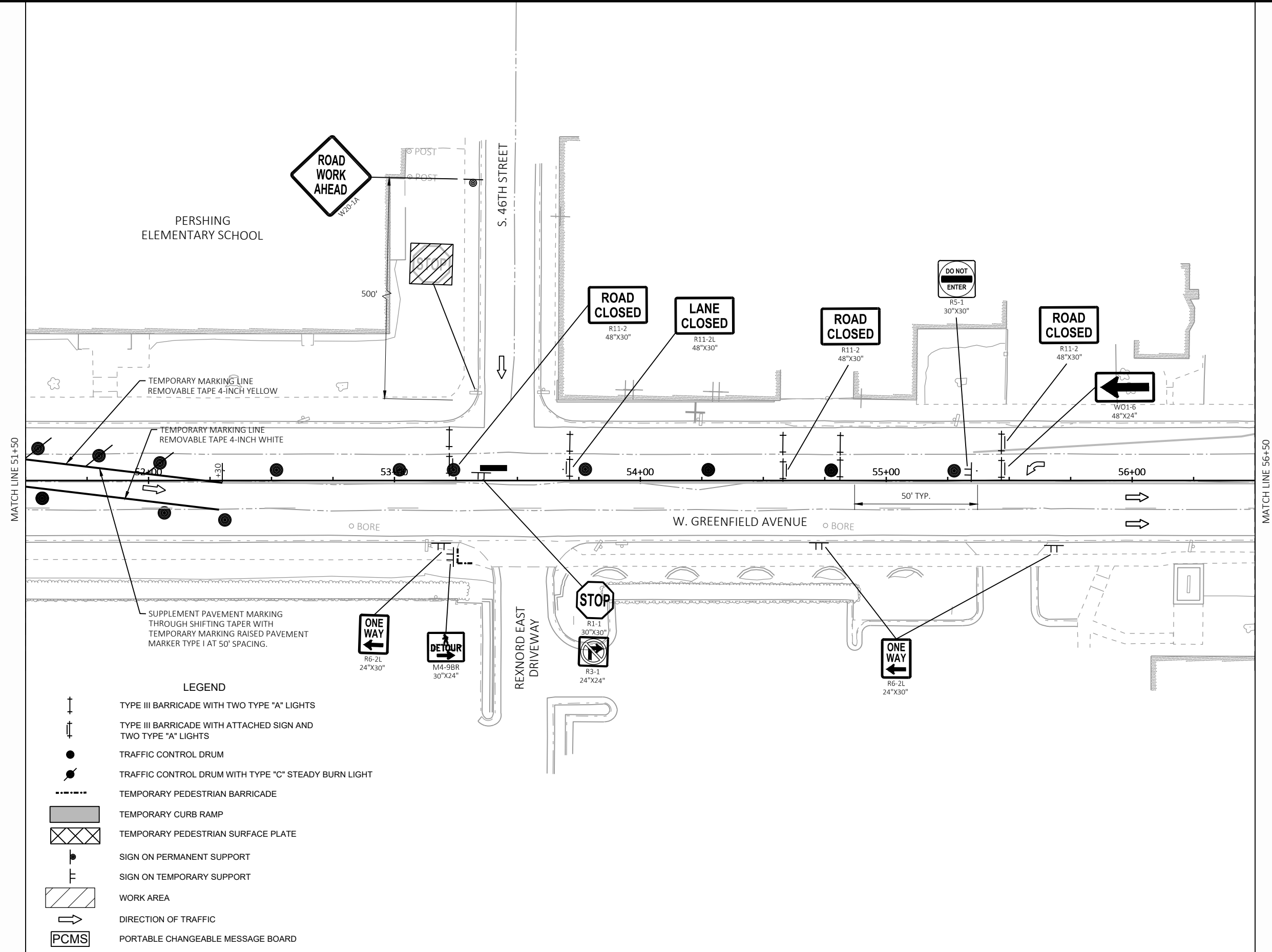

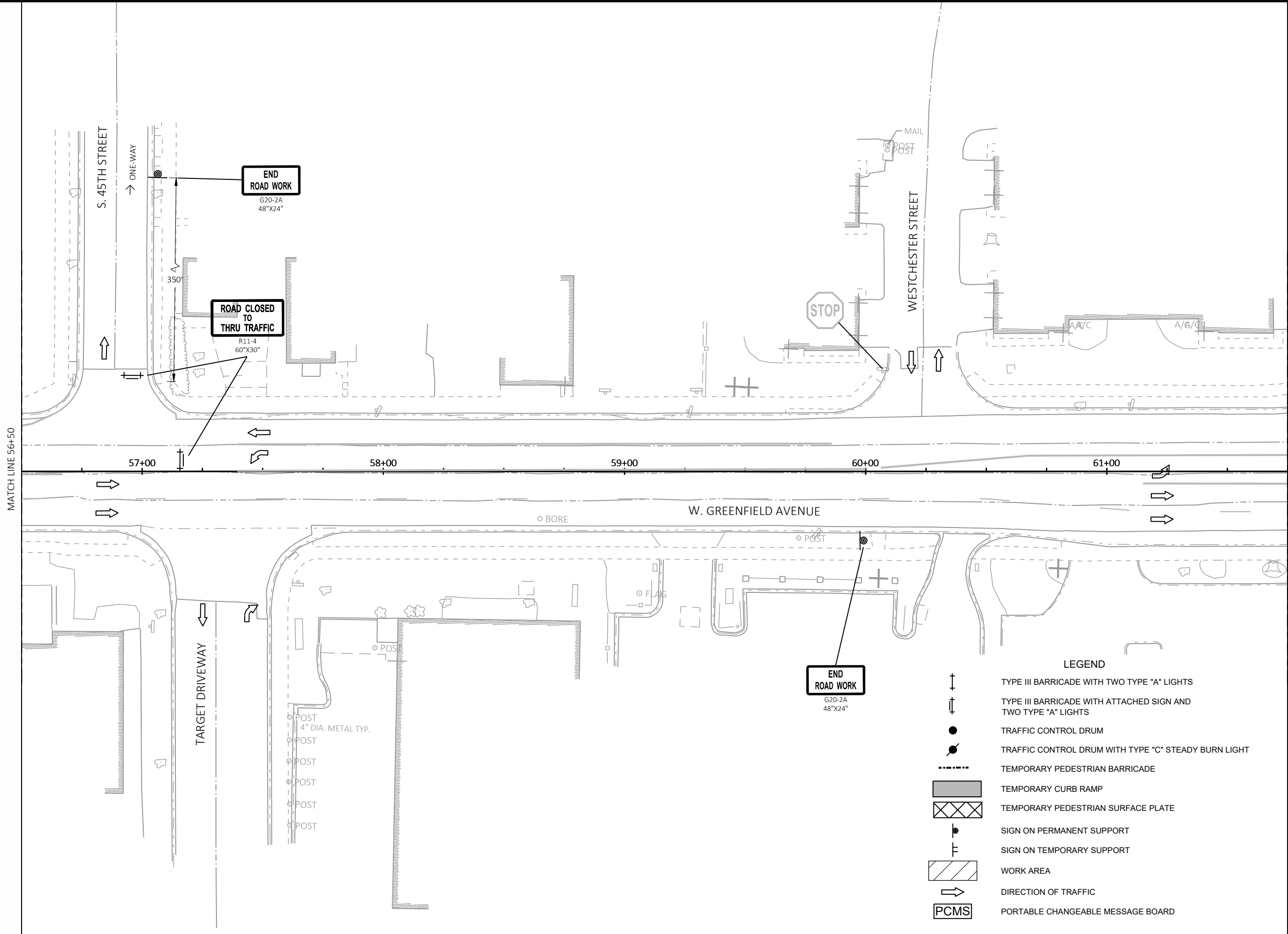

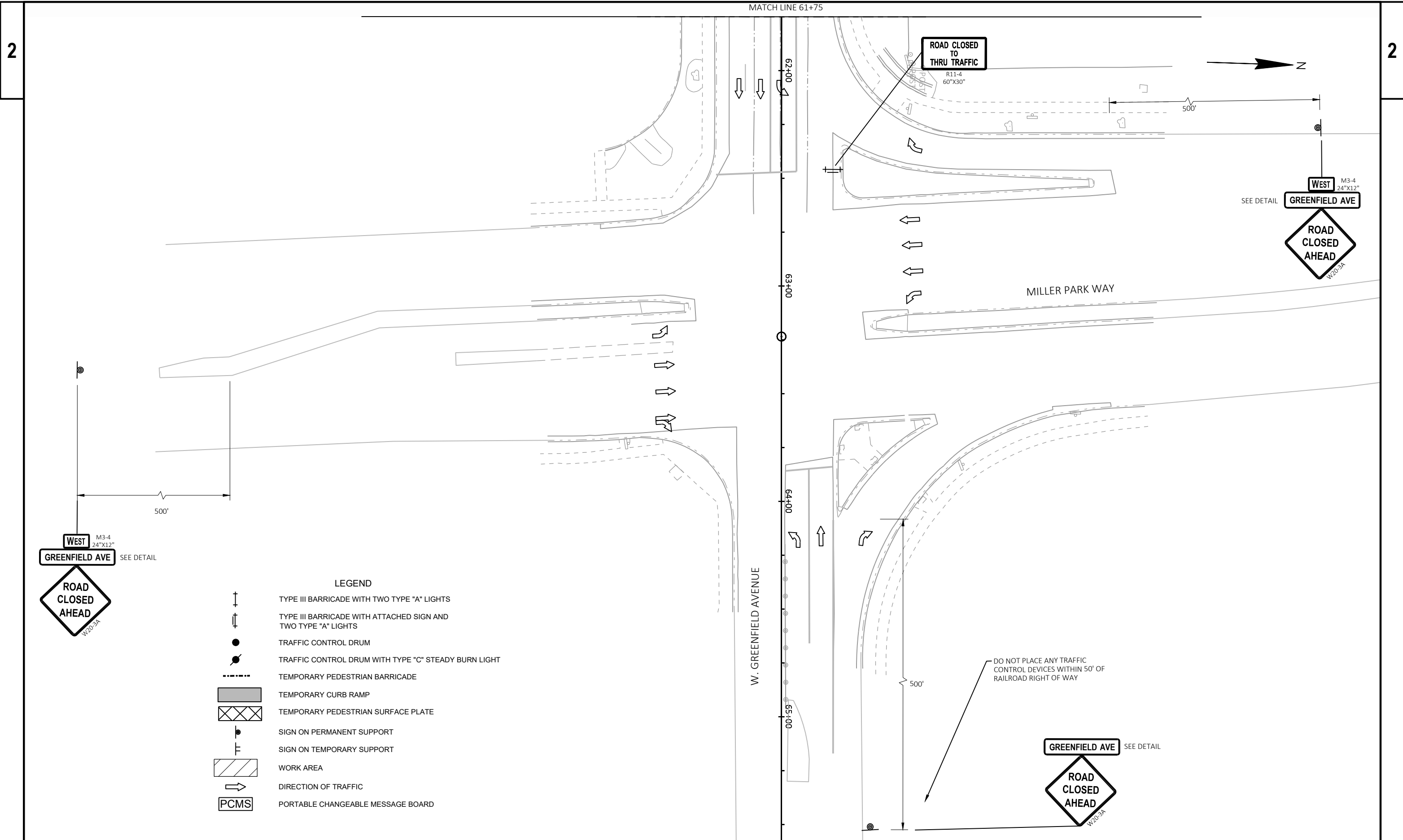













- LEGEND**
- ⊥ TYPE III BARRICADE WITH TWO TYPE "A" LIGHTS
 - ⊥ TYPE III BARRICADE WITH ATTACHED SIGN AND TWO TYPE "A" LIGHTS
 - TRAFFIC CONTROL DRUM
 - TRAFFIC CONTROL DRUM WITH TYPE "C" STEADY BURN LIGHT
 - TEMPORARY PEDESTRIAN BARRICADE
 - ▭ TEMPORARY CURB RAMP
 - ▭ TEMPORARY PEDESTRIAN SURFACE PLATE
 - SIGN ON PERMANENT SUPPORT
 - ⊥ SIGN ON TEMPORARY SUPPORT
 - ▨ WORK AREA
 - DIRECTION OF TRAFFIC
 - PCMS PORTABLE CHANGEABLE MESSAGE BOARD







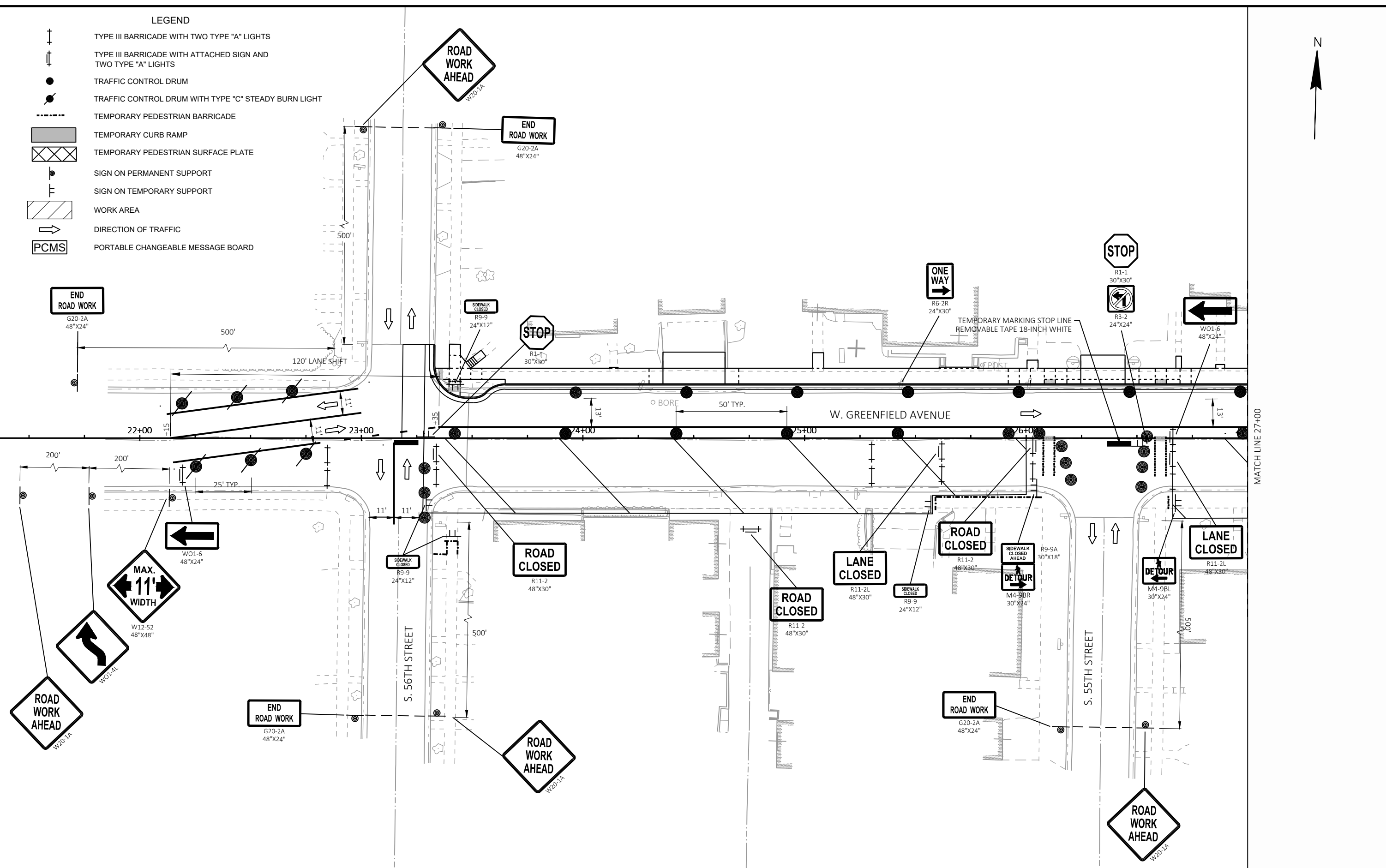





PROJECT NO: 2230-07-73	HWY: W. GREENFIELD AVENUE	COUNTY: MILWAUKEE	TRAFFIC CONTROL - STAGE 2A & 2B	SHEET	E
------------------------	---------------------------	-------------------	---------------------------------	-------	----------

LEGEND

-  TYPE III BARRICADE WITH TWO TYPE "A" LIGHTS
-  TYPE III BARRICADE WITH ATTACHED SIGN AND TWO TYPE "A" LIGHTS
-  TRAFFIC CONTROL DRUM
-  TRAFFIC CONTROL DRUM WITH TYPE "C" STEADY BURN LIGHT
-  TEMPORARY PEDESTRIAN BARRICADE
-  TEMPORARY CURB RAMP
-  TEMPORARY PEDESTRIAN SURFACE PLATE
-  SIGN ON PERMANENT SUPPORT
-  SIGN ON TEMPORARY SUPPORT
-  WORK AREA
-  DIRECTION OF TRAFFIC
-  PORTABLE CHANGEABLE MESSAGE BOARD



LEGEND

-  TYPE III BARRICADE WITH TWO TYPE "A" LIGHTS
-  TYPE III BARRICADE WITH ATTACHED SIGN AND TWO TYPE "A" LIGHTS
-  TRAFFIC CONTROL DRUM
-  TRAFFIC CONTROL DRUM WITH TYPE "C" STEADY BURN LIGHT
-  TEMPORARY PEDESTRIAN BARRICADE
-  TEMPORARY CURB RAMP
-  TEMPORARY PEDESTRIAN SURFACE PLATE
-  SIGN ON PERMANENT SUPPORT
-  SIGN ON TEMPORARY SUPPORT
-  WORK AREA
-  DIRECTION OF TRAFFIC
-  PORTABLE CHANGEABLE MESSAGE BOARD

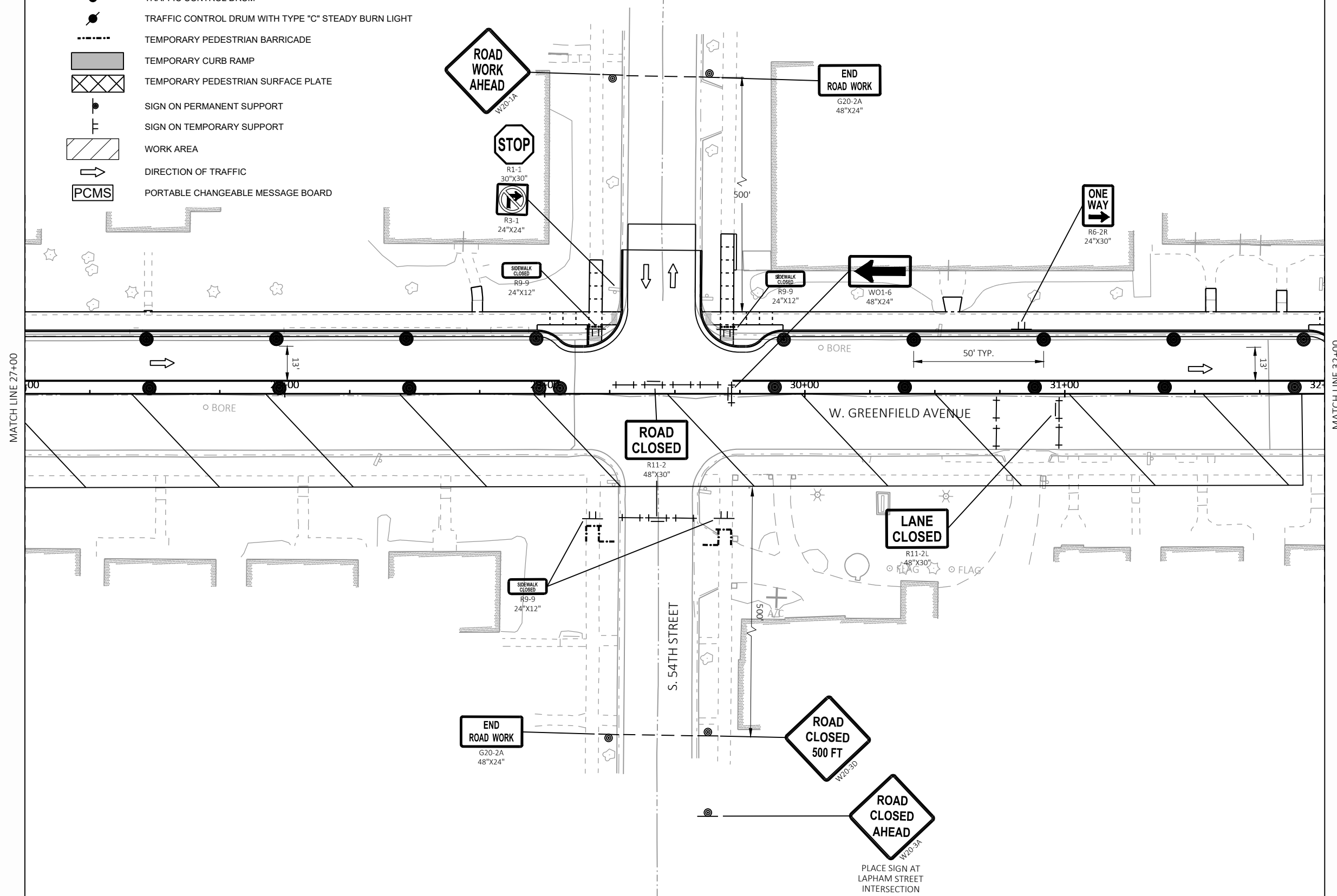

LEGEND

- TYPE III BARRICADE WITH TWO TYPE "A" LIGHTS
- TYPE III BARRICADE WITH ATTACHED SIGN AND TWO TYPE "A" LIGHTS
- TRAFFIC CONTROL DRUM
- TRAFFIC CONTROL DRUM WITH TYPE "C" STEADY BURN LIGHT
- TEMPORARY PEDESTRIAN BARRICADE
- TEMPORARY CURB RAMP
- TEMPORARY PEDESTRIAN SURFACE PLATE
- SIGN ON PERMANENT SUPPORT
- SIGN ON TEMPORARY SUPPORT
- WORK AREA
- DIRECTION OF TRAFFIC
- PORTABLE CHANGEABLE MESSAGE BOARD

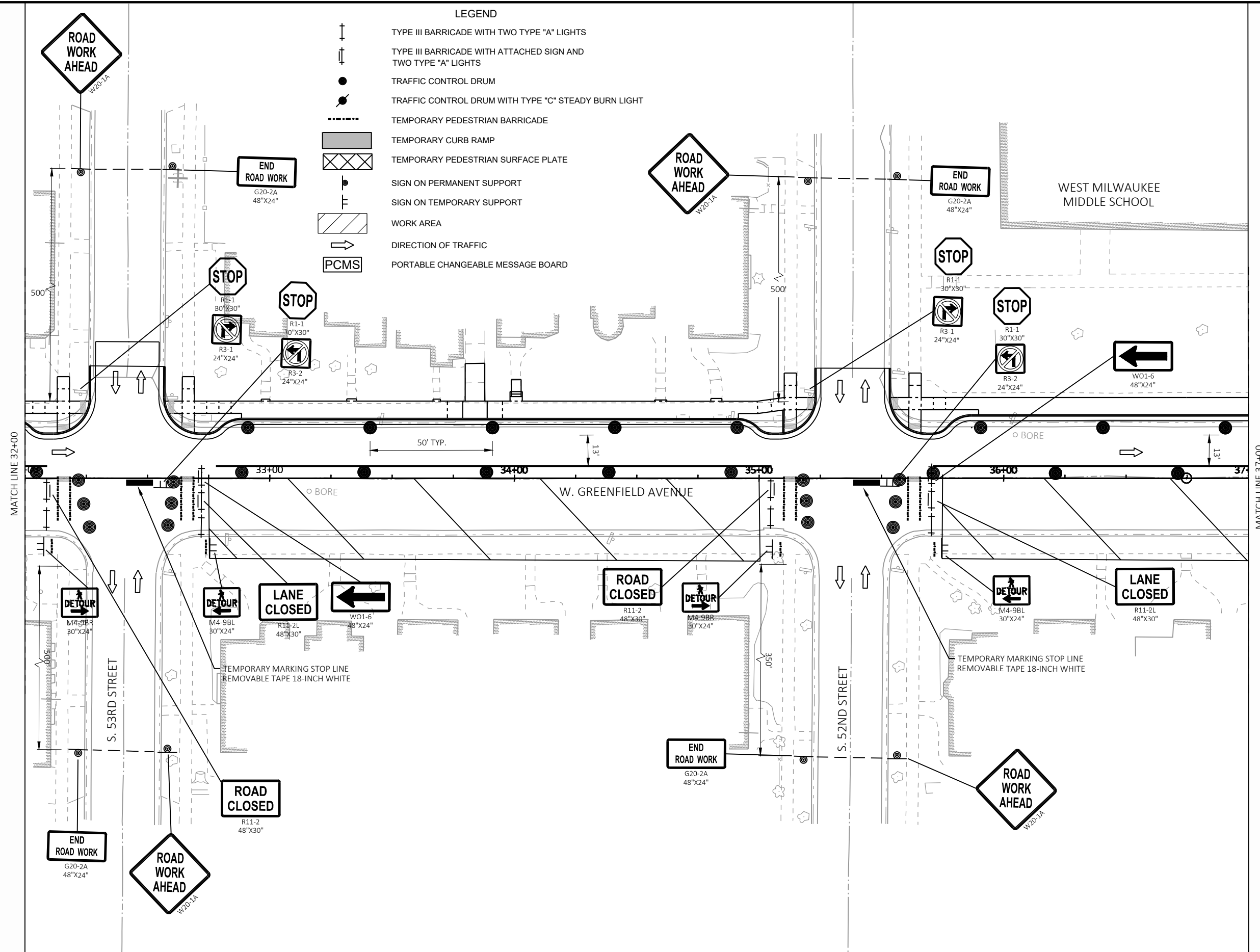

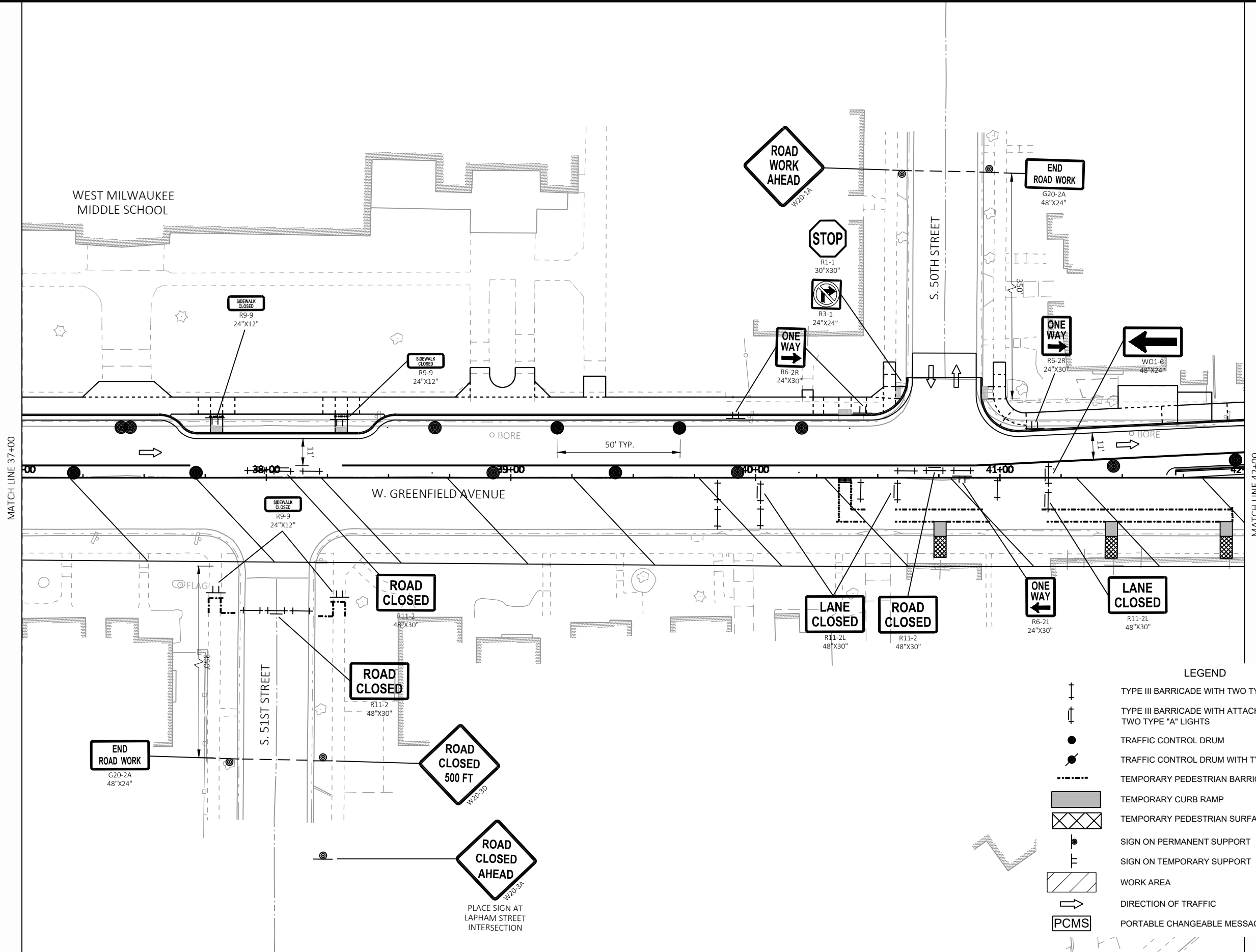

LEGEND

	TYPE III BARRICADE WITH TWO TYPE "A" LIGHTS
	TYPE III BARRICADE WITH ATTACHED SIGN AND TWO TYPE "A" LIGHTS
	TRAFFIC CONTROL DRUM
	TRAFFIC CONTROL DRUM WITH TYPE "C" STEADY BURN LIGHT
	TEMPORARY PEDESTRIAN BARRICADE
	TEMPORARY CURB RAMP
	TEMPORARY PEDESTRIAN SURFACE PLATE
	SIGN ON PERMANENT SUPPORT
	SIGN ON TEMPORARY SUPPORT
	WORK AREA
	DIRECTION OF TRAFFIC
	PORTABLE CHANGEABLE MESSAGE BOARD

PROJECT NO: 2230-07-73 HWY: W. GREENFIELD AVENUE COUNTY: MILWAUKEE TRAFFIC CONTROL - STAGE 2B SHEET E

FILE NAME : X:\ML\2021\20210099\DESIGN\TRANSPORTATION\SHEETSPLAN\026102_S2B.DWG PLOT DATE : 7/19/2023 1:14 PM PLOT BY : BIEBERITZ, BEN PLOT NAME : PLOT SCALE : 1 IN=40 FT WISDOT/CADD SHEET 42

LAYOUT NAME - 026124_s2b

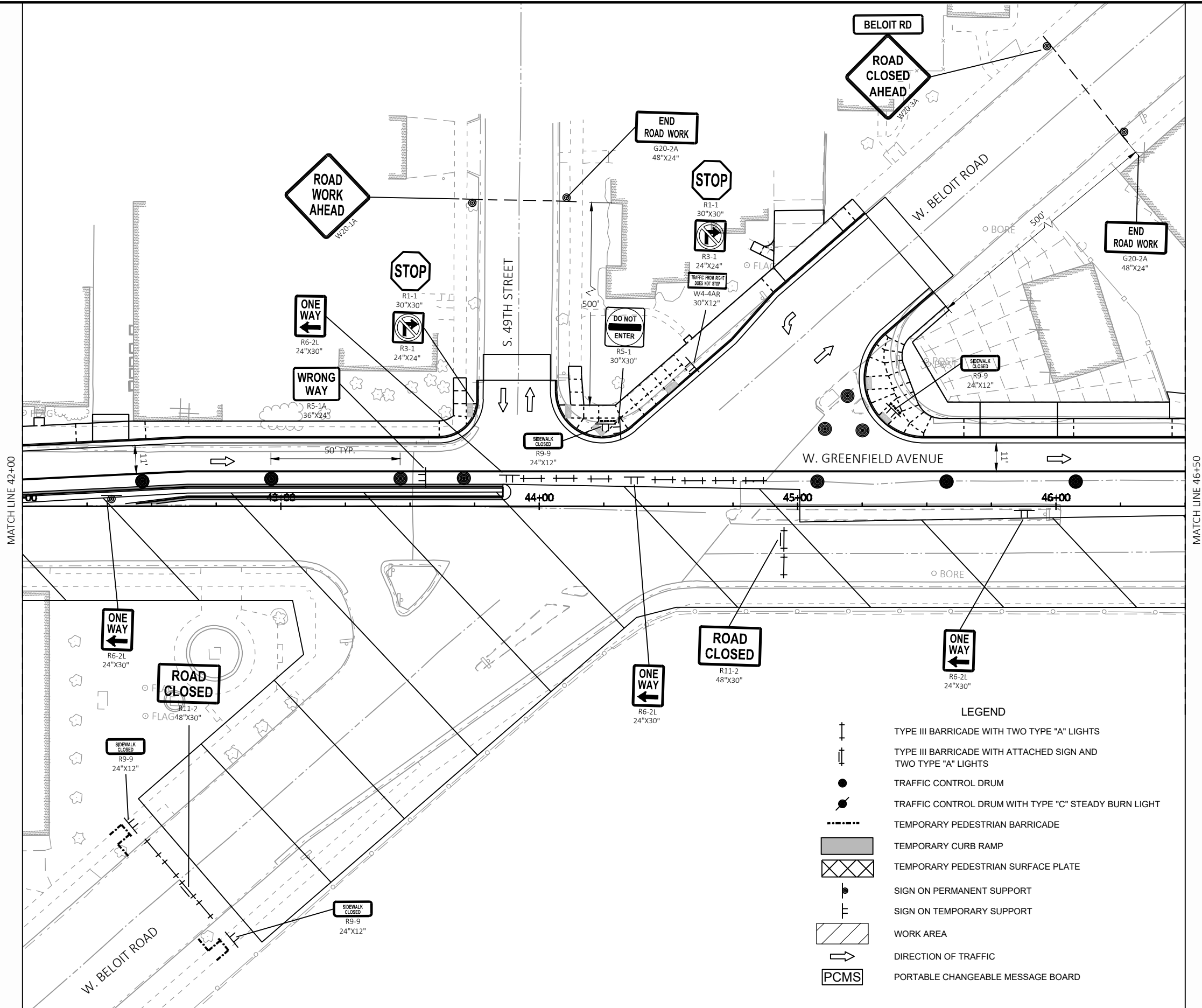

LEGEND

	TYPE III BARRICADE WITH TWO TYPE "A" LIGHTS
	TYPE III BARRICADE WITH ATTACHED SIGN AND TWO TYPE "A" LIGHTS
	TRAFFIC CONTROL DRUM
	TRAFFIC CONTROL DRUM WITH TYPE "C" STEADY BURN LIGHT
	TEMPORARY PEDESTRIAN BARRICADE
	TEMPORARY CURB RAMP
	TEMPORARY PEDESTRIAN SURFACE PLATE
	SIGN ON PERMANENT SUPPORT
	SIGN ON TEMPORARY SUPPORT
	WORK AREA
	DIRECTION OF TRAFFIC
	PORTABLE CHANGEABLE MESSAGE BOARD

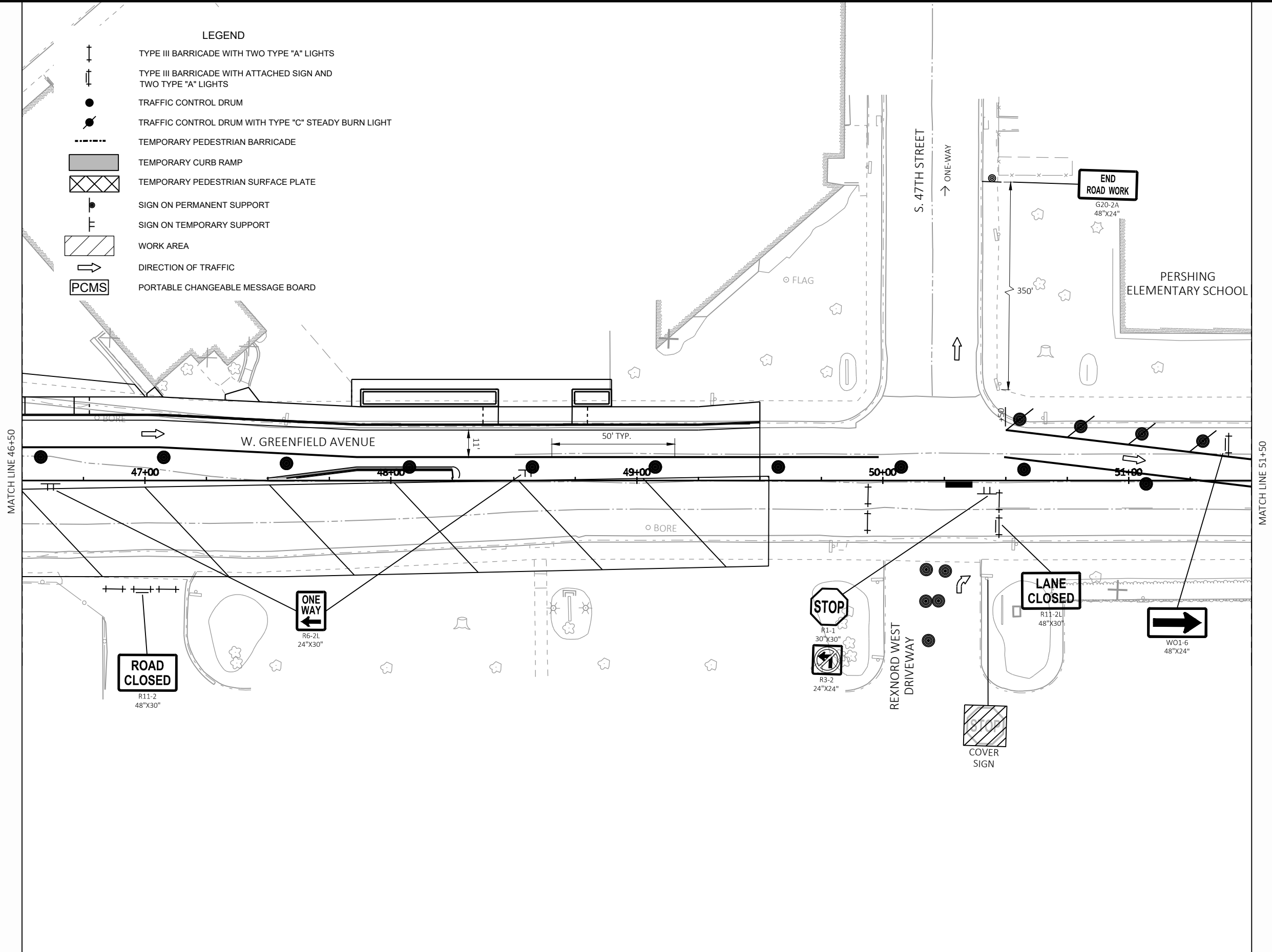

NOTES



THE EXACT NUMBER, LOCATION AND SPACING OF ALL SIGNS SHALL BE ADJUSTED TO FIT FIELD CONDITIONS.

IF THERE ARE EXISTING ROUTE MARKER ASSEMBLIES THAT WILL REMAIN IN PLACE, ADJUST THE LOCATION OF THE DETOUR SIGNS TO CORRESPOND WITH THE EXISTING ASSEMBLIES.

THE SPACING BETWEEN THE TRAFFIC CONTROL AND DETOUR SIGNS SHOULD BE ADJUSTED NOT TO CONFLICT WITH AND TO PROVIDE A MINIMUM OF 200' CLEARANCE TO EXISTING SIGNS THAT WILL REMAIN IN PLACE.

FOLLOW SDD "BARRICADES AND SIGNS FOR MAINLINE CLOSURES" FOR MAINLINE ROAD CLOSED SIGNAGE.

LEGEND

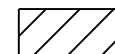
-  DETOUR ROUTE
-  TEMPORARY TRAFFIC CONTROL SIGN POST
-  TYPE III BARRICADE WITH ATTACHED SIGN AND TWO TYPE "A" LIGHTS
-  WORK ZONE



CITY OF MILWAUKEE

CONCRETE PAVEMENT GAPS REQUIRED TO MAINTAIN ACCESS TO ALTERNATING SIDE ROADS FROM 54TH TO 50TH STREET DURING CONSTRUCTION

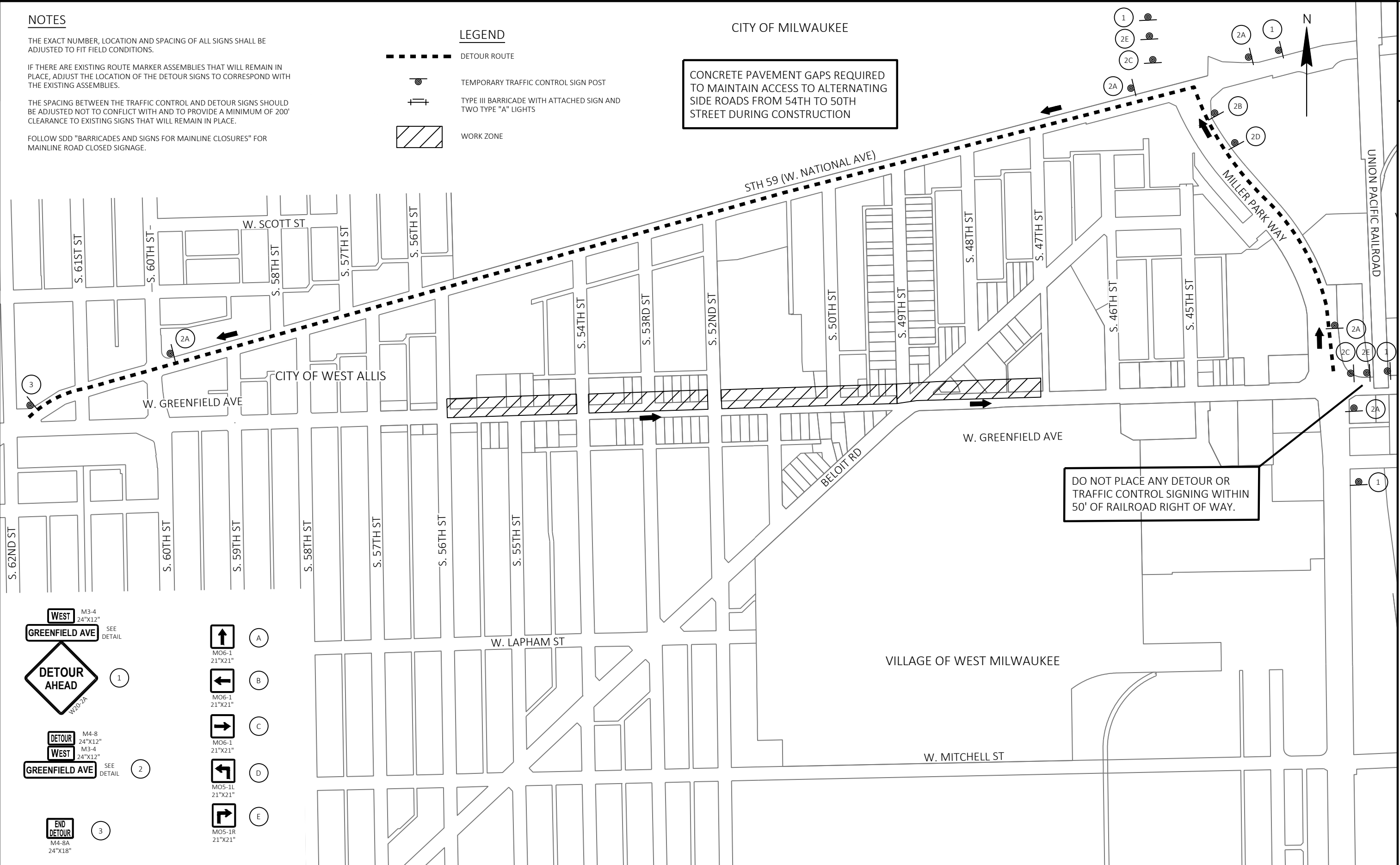
DO NOT PLACE ANY DETOUR OR TRAFFIC CONTROL SIGNING WITHIN 50' OF RAILROAD RIGHT OF WAY.

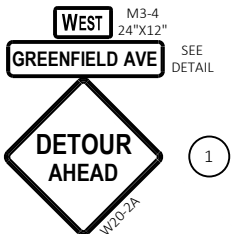
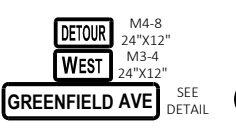
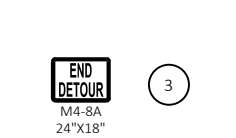

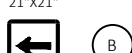
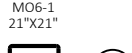
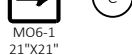
-  1
-  2
-  3

-  A
-  B
-  C
-  D
-  E

NOTES

THE EXACT NUMBER, LOCATION AND SPACING OF ALL SIGNS SHALL BE ADJUSTED TO FIT FIELD CONDITIONS.

IF THERE ARE EXISTING ROUTE MARKER ASSEMBLIES THAT WILL REMAIN IN PLACE, ADJUST THE LOCATION OF THE DETOUR SIGNS TO CORRESPOND WITH THE EXISTING ASSEMBLIES.

THE SPACING BETWEEN THE TRAFFIC CONTROL AND DETOUR SIGNS SHOULD BE ADJUSTED NOT TO CONFLICT WITH AND TO PROVIDE A MINIMUM OF 200' CLEARANCE TO EXISTING SIGNS THAT WILL REMAIN IN PLACE.

FOLLOW SDD "BARRICADES AND SIGNS FOR MAINLINE CLOSURES" FOR MAINLINE ROAD CLOSED SIGNAGE.

LEGEND

- DETOUR ROUTE
- ⊙ TEMPORARY TRAFFIC CONTROL SIGN POST
- ⊕ TYPE III BARRICADE WITH ATTACHED SIGN
- ▨ WORK ZONE

CITY OF MILWAUKEE

CONCRETE PAVEMENT GAPS REQUIRED TO MAINTAIN ACCESS TO ALTERNATING SIDE ROADS FROM 54TH TO 50TH STREET DURING CONSTRUCTION

DO NOT PLACE ANY DETOUR OR TRAFFIC CONTROL SIGNING WITHIN 50' OF RAILROAD RIGHT OF WAY.

ROAD CLOSED TO THRU TRAFFIC
R11-4
60"X30"

ROAD CLOSED 500 FT
W20-30

ROAD CLOSED 1000 FT
W20-2C

ROAD CLOSED AHEAD
W20-2A

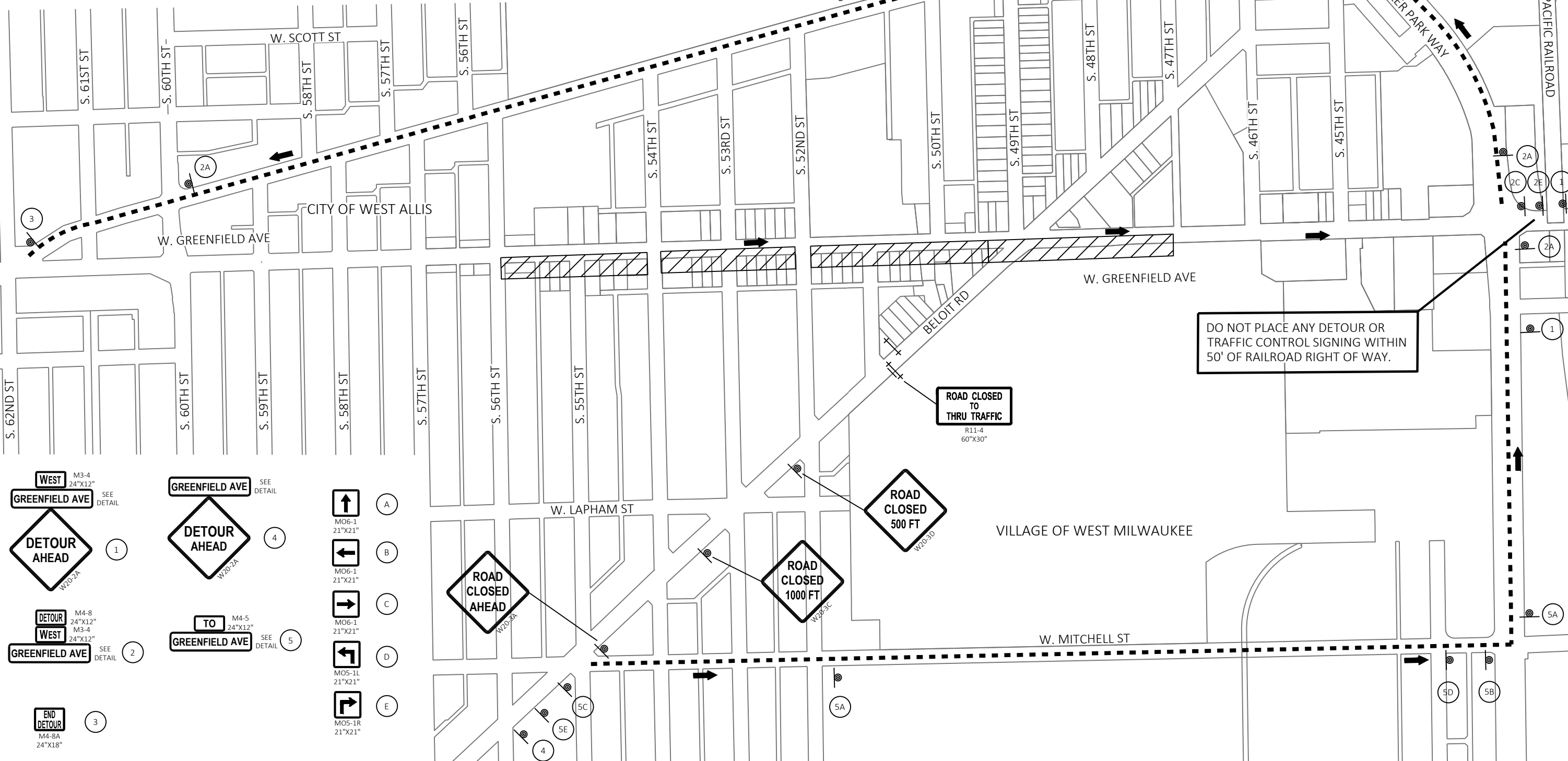



WEST M3-4 24"X12" SEE DETAIL
GREENFIELD AVE SEE DETAIL
DETOUR AHEAD 1
DETOUR AHEAD 4
DETOUR M4-8 24"X12" SEE DETAIL
WEST M3-4 24"X12" SEE DETAIL
GREENFIELD AVE SEE DETAIL
TO M4-5 24"X12" SEE DETAIL
GREENFIELD AVE SEE DETAIL
END DETOUR 3
 M4-8A 24"X18"

A
M06-1 21"X21"
 B
M06-1 21"X21"
 C
M06-1 21"X21"
 D
M05-1L 21"X21"
 E
M05-1R 21"X21"

LEGEND

 SIGN ON PERMANENT SUPPORT

 DETOUR ROUTE

 WORK AREA

NOTE: SEE TRAFFIC CONTROL PLANS FOR ADDITIONAL SIGNING

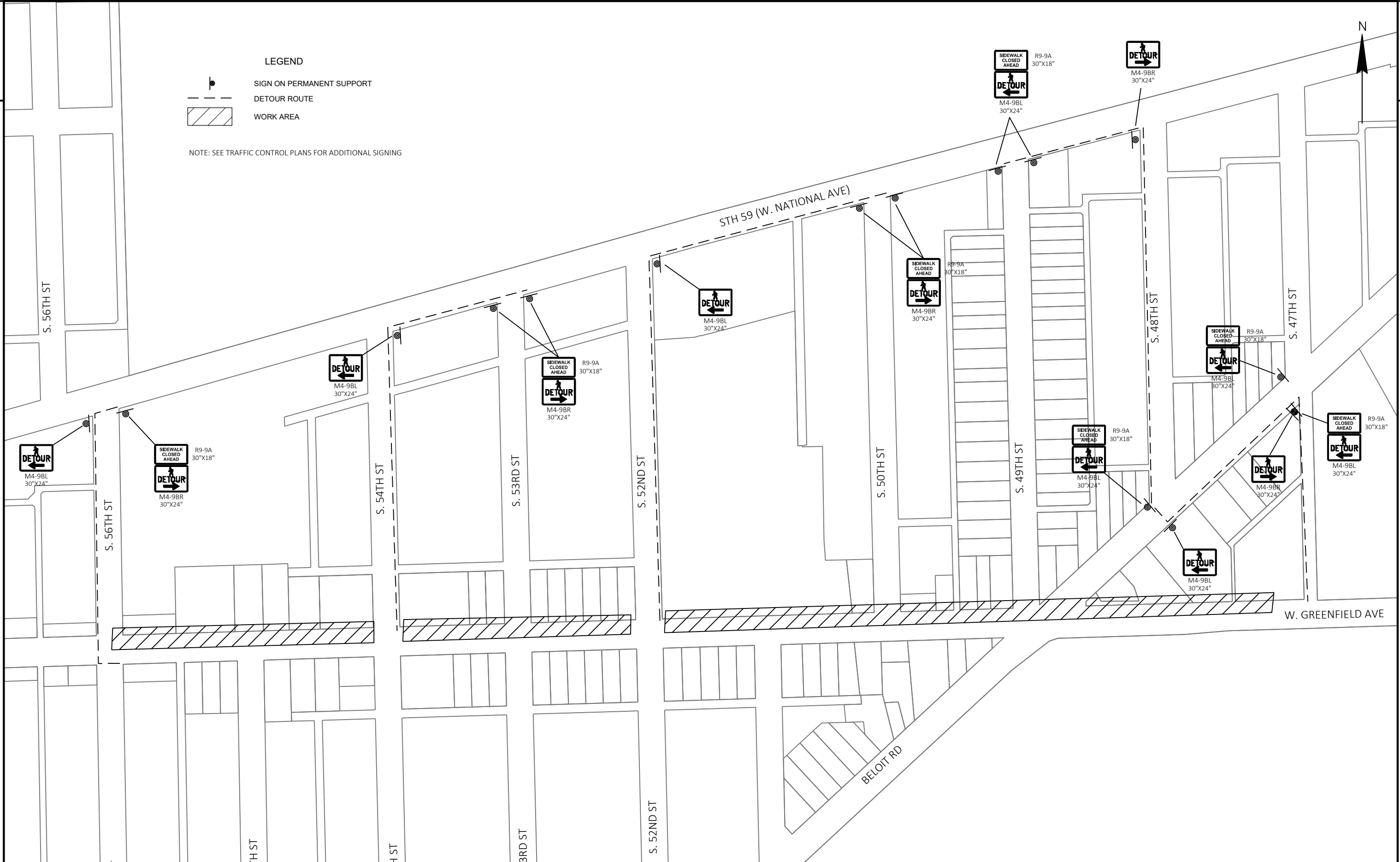

PROJECT NO: 2230-07-73	HWY: W. GREENFIELD AVENUE	COUNTY: MILWAUKEE	PEDESTRIAN DETOUR - STAGE 1A	SHEET	E
------------------------	---------------------------	-------------------	------------------------------	-------	----------

LEGEND

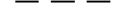
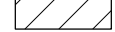
-  SIGN ON PERMANENT SUPPORT
-  DETOUR ROUTE
-  WORK AREA

NOTE: SEE TRAFFIC CONTROL PLANS FOR ADDITIONAL SIGNING

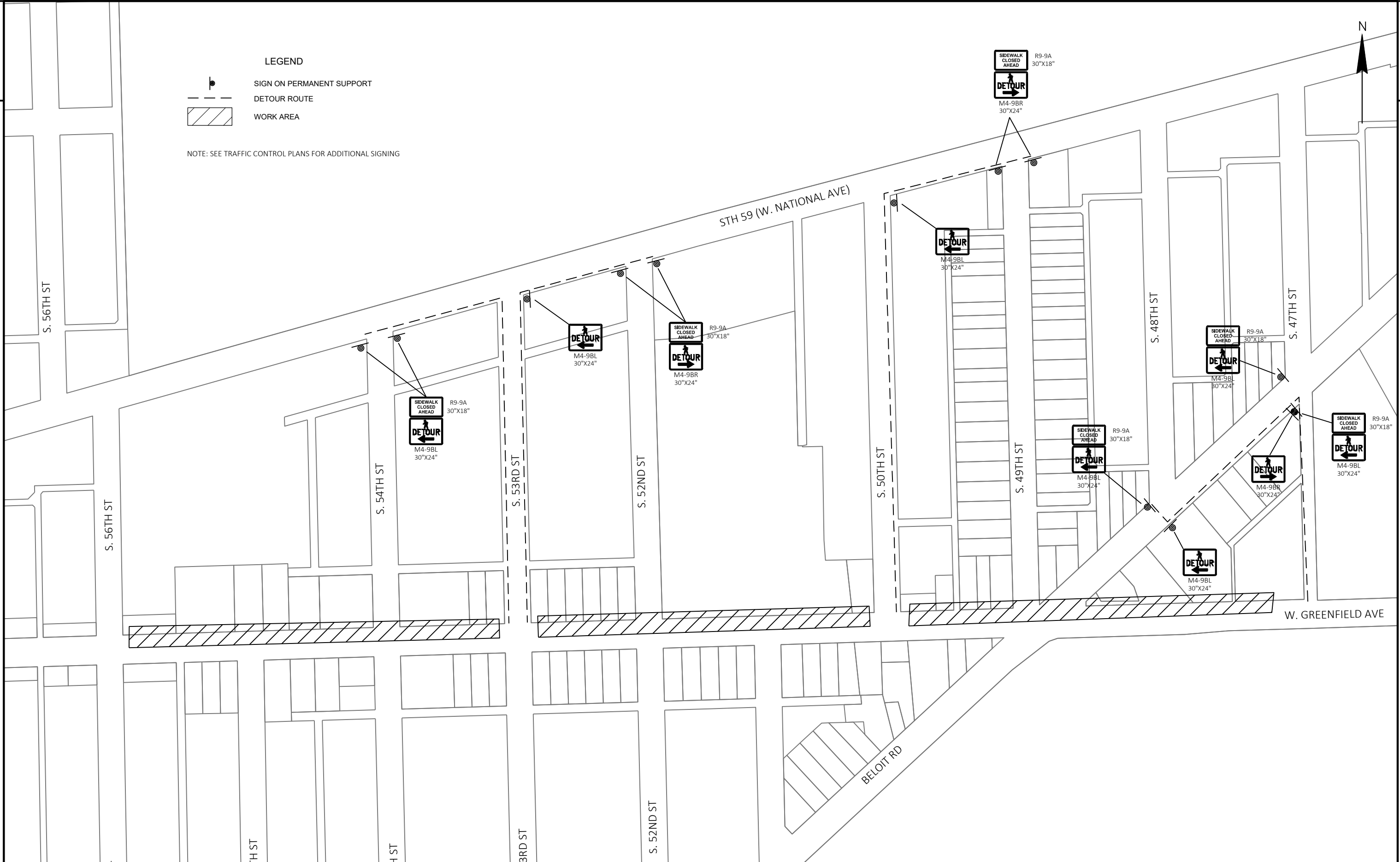

PROJECT NO: 2230-07-73	HWY: W. GREENFIELD AVENUE	COUNTY: MILWAUKEE	PEDESTRIAN DETOUR - STAGE 1B	SHEET	E
------------------------	---------------------------	-------------------	------------------------------	-------	----------

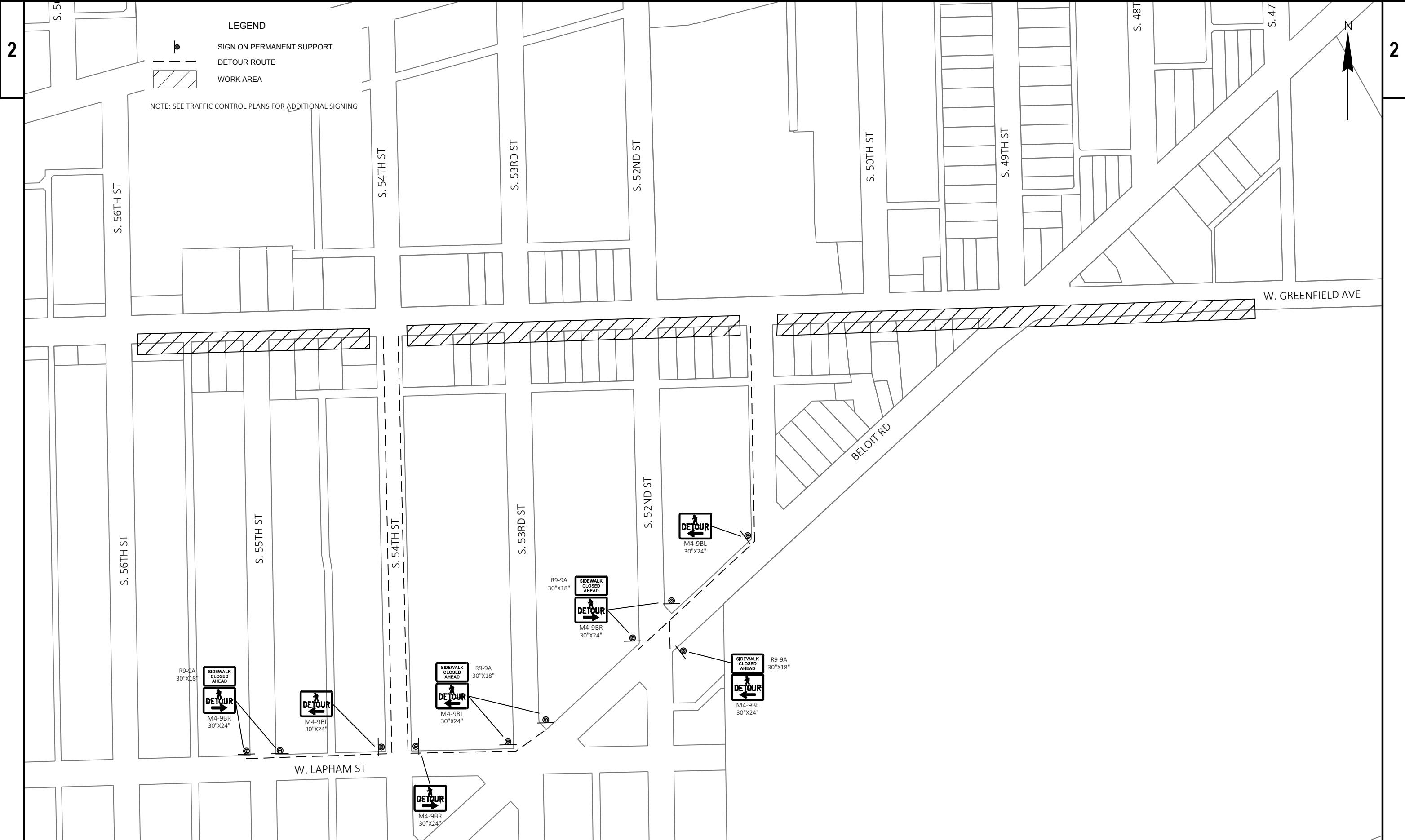

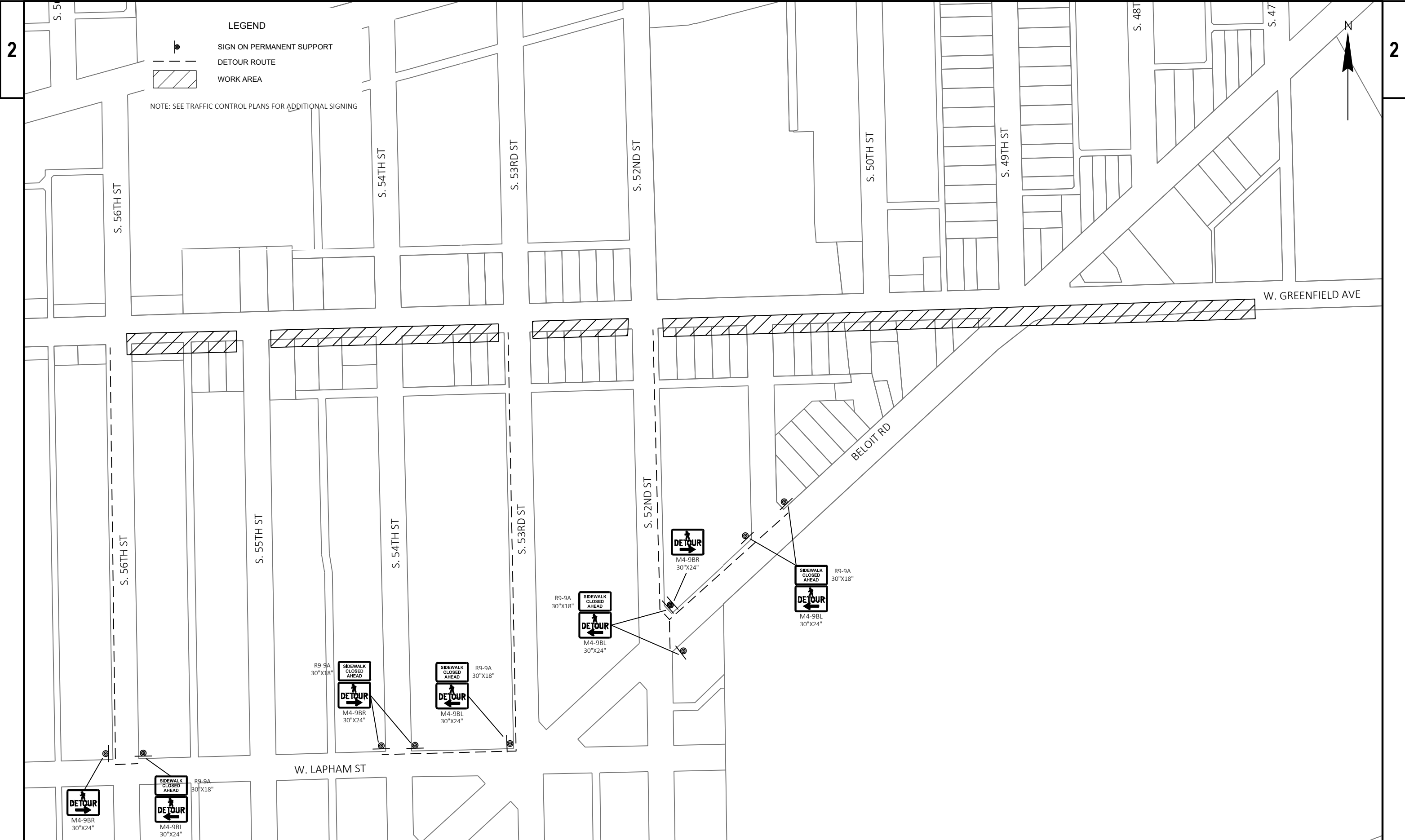

LEGEND

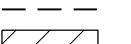
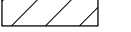
-  SIGN ON PERMANENT SUPPORT
-  DETOUR ROUTE
-  WORK AREA

NOTE: SEE TRAFFIC CONTROL PLANS FOR ADDITIONAL SIGNING



CONTROL POINTS					
NUMBER	DESCRIPTION	STATION	OFFSET	N	E
2	CP REBAR WITH YELLOW GRAEF-USA CAP	26+53.26	31.08' LT	377,173.01	2,540,043.04
3	CP REBAR WITH YELLOW GRAEF-USA CAP	29+23.10	31.60' RT	377,118.43	2,540,314.63
4	CP CUT CROSS	32+19.26	31.56' LT	377,190.41	2,540,608.77
5	CP REBAR WITH YELLOW GRAEF-USA CAP	35+59.46	34.68' RT	377,134.37	2,540,950.80
6	CP REBAR WITH YELLOW GRAEF-USA CAP	38+04.01	35.96' LT	377,212.40	2,541,193.10
7	CP REBAR WITH YELLOW GRAEF-USA CAP	40+95.88	31.87' LT	377,217.29	2,541,484.95
8	CP REBAR WITH YELLOW GRAEF-USA CAP	42+25.78	31.31' RT	377,158.14	2,541,616.74
9	CP CUT CROSS	44+04.74	39.74' RT	377,155.22	2,541,795.87
10	CP REBAR WITH YELLOW GRAEF-USA CAP	47+41.71	38.97' RT	377,166.35	2,542,132.66
12	CP REBAR WITH YELLOW GRAEF-USA CAP	50+45.17	33.26' RT	377,181.39	2,542,435.80
13	CP CUT CROSS	53+14.44	26.45' LT	377,249.36	2,542,703.10
14	CP CUT CROSS	54+70.29	34.38' RT	377,193.35	2,542,860.75

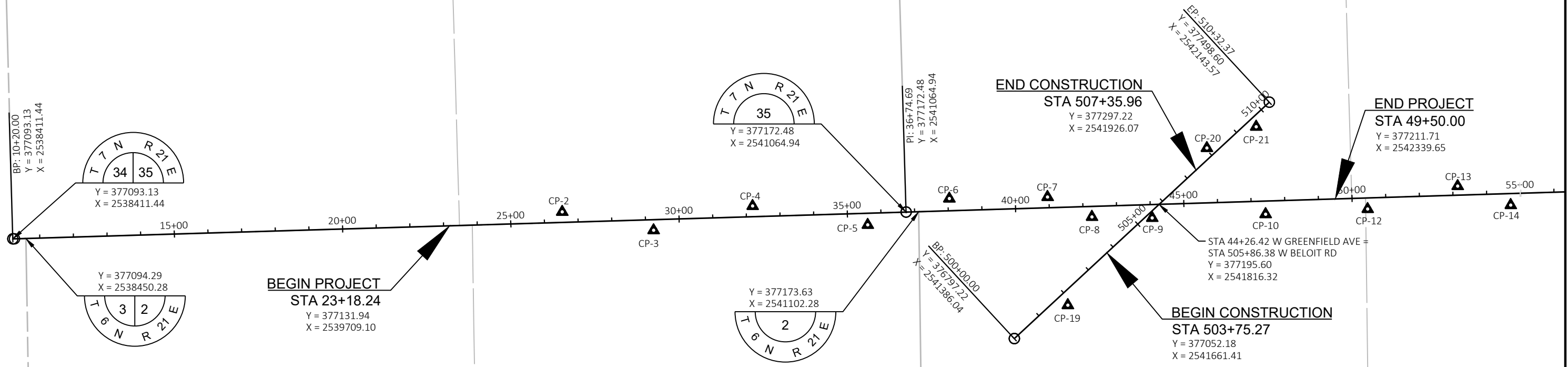

Estimate Of Quantities

2230-07-73

Line	Item	Item Description	Unit	Total	Qty
0002	201.0120	Clearing	ID	100.000	100.000
0004	201.0220	Grubbing	ID	100.000	100.000
0006	204.0100	Removing Concrete Pavement	SY	17,551.000	17,551.000
0008	204.0115	Removing Asphaltic Surface Butt Joints	SY	79.000	79.000
0010	204.0120	Removing Asphaltic Surface Milling	SY	379.000	379.000
0012	204.0155	Removing Concrete Sidewalk	SY	4,334.000	4,334.000
0014	204.0195	Removing Concrete Bases	EACH	41.000	41.000
0016	204.0210	Removing Manholes	EACH	2.000	2.000
0018	204.0220	Removing Inlets	EACH	38.000	38.000
0020	204.0245	Removing Storm Sewer (size) 01. 12-Inch	LF	944.000	944.000
0022	204.0291.S	Abandoning Sewer 01. Sta. 46+85	CY	5.000	5.000
0024	204.9060.S	Removing (item description) 01. Flashing Beacons & Mast Arms	EACH	2.000	2.000
0026	204.9060.S	Removing (item description) 02. Concrete Fence Bases	EACH	1.000	1.000
0028	204.9060.S	Removing (item description) 03. Steps Railing	EACH	3.000	3.000
0030	204.9060.S	Removing (item description) 04. Traffic Signals-W Greenfield Ave & W Beloit Rd	EACH	1.000	1.000
0032	204.9060.S	Removing (item description) 05. Lighting units	EACH	31.000	31.000
0034	204.9165.S	Removing (item description) 01. Concrete Steps	SF	91.000	91.000
0036	205.0100	Excavation Common	CY	17,921.000	17,921.000
0038	213.0100	Finishing Roadway (project) 01. 2230-07-73	EACH	1.000	1.000
0040	305.0120	Base Aggregate Dense 1 1/4-Inch	TON	7,739.000	7,739.000
0042	310.0110	Base Aggregate Open-Graded	TON	46.000	46.000
0044	311.0110	Breaker Run	TON	16,108.000	16,108.000
0046	405.0100	Coloring Concrete WisDOT Red	CY	43.000	43.000
0048	415.0080	Concrete Pavement 8-Inch	SY	14,750.000	14,750.000
0050	415.0210	Concrete Pavement Gaps	EACH	4.000	4.000
0052	415.4100	Concrete Pavement Joint Filling	SY	14,750.000	14,750.000
0054	416.0610	Drilled Tie Bars	EACH	14.000	14.000
0056	416.0620	Drilled Dowel Bars	EACH	326.000	326.000
0058	455.0605	Tack Coat	GAL	23.000	23.000
0060	460.2000	Incentive Density HMA Pavement	DOL	30.000	30.000
0062	460.5224	HMA Pavement 4 LT 58-28 S	TON	43.000	43.000
0064	465.0120	Asphaltic Surface Driveways and Field Entrances	TON	31.000	31.000
0066	465.0125	Asphaltic Surface Temporary	TON	12.000	12.000
0068	513.2001	Railing Pipe	LF	12.000	12.000
0070	601.0405	Concrete Curb & Gutter 18-Inch Type A	LF	1,132.000	1,132.000
0072	601.0409	Concrete Curb & Gutter 30-Inch Type A	LF	5,743.000	5,743.000
0074	601.0600	Concrete Curb Pedestrian	LF	57.000	57.000
0076	602.0410	Concrete Sidewalk 5-Inch	SF	36,943.000	36,943.000
0078	602.0505	Curb Ramp Detectable Warning Field Yellow	SF	487.000	487.000
0080	602.0815	Concrete Driveway 7-Inch	SY	663.000	663.000
0082	602.1500	Concrete Steps	SF	91.000	91.000
0084	608.0312	Storm Sewer Pipe Reinforced Concrete Class III 12-Inch	LF	690.000	690.000
0086	608.0315	Storm Sewer Pipe Reinforced Concrete Class III 15-Inch	LF	21.000	21.000
0088	611.0530	Manhole Covers Type J	EACH	3.000	3.000
0090	611.0624	Inlet Covers Type H	EACH	17.000	17.000
0092	611.0639	Inlet Covers Type H-S	EACH	18.000	18.000
0094	611.0648	Inlet Covers Type R	EACH	3.000	3.000
0096	611.0651	Inlet Covers Type S	EACH	1.000	1.000
0098	611.1003	Catch Basins 3-FT Diameter	EACH	4.000	4.000
0100	611.1230	Catch Basins 2x3-FT	EACH	35.000	35.000

Estimate Of Quantities

2230-07-73

Line	Item	Item Description	Unit	Total	Qty
0102	611.2004	Manholes 4-FT Diameter	EACH	3.000	3.000
0104	611.8110	Adjusting Manhole Covers	EACH	37.000	37.000
0106	612.0106	Pipe Underdrain 6-Inch	LF	500.000	500.000
0108	612.0902.S	Insulation Board Polystyrene (inch) 01. 3	SY	5.300	5.300
0110	619.1000	Mobilization	EACH	1.000	1.000
0112	620.0300	Concrete Median Sloped Nose	SF	93.000	93.000
0114	624.0100	Water	MGAL	111.000	111.000
0116	625.0100	Topsoil	SY	2,036.000	2,036.000
0118	628.1905	Mobilizations Erosion Control	EACH	3.000	3.000
0120	628.1910	Mobilizations Emergency Erosion Control	EACH	3.000	3.000
0122	628.7005	Inlet Protection Type A	EACH	34.000	34.000
0124	628.7010	Inlet Protection Type B	EACH	1.000	1.000
0126	628.7015	Inlet Protection Type C	EACH	65.000	65.000
0128	628.7020	Inlet Protection Type D	EACH	11.000	11.000
0130	628.7560	Tracking Pads	EACH	2.000	2.000
0132	629.0210	Fertilizer Type B	CWT	1.300	1.300
0134	631.0300	Sod Water	MGAL	92.000	92.000
0136	631.1000	Sod Lawn	SY	2,036.000	2,036.000
0138	637.2210	Signs Type II Reflective H	SF	277.660	277.660
0140	637.2215	Signs Type II Reflective H Folding	SF	20.720	20.720
0142	637.2220	Signs Type II Reflective SH	SF	26.500	26.500
0144	637.2230	Signs Type II Reflective F	SF	215.500	215.500
0146	638.2102	Moving Signs Type II	EACH	43.000	43.000
0148	638.2602	Removing Signs Type II	EACH	106.000	106.000
0150	638.3000	Removing Small Sign Supports	EACH	46.000	46.000
0152	642.5401	Field Office Type D	EACH	1.000	1.000
0154	643.0300	Traffic Control Drums	DAY	20,061.000	20,061.000
0156	643.0420	Traffic Control Barricades Type III	DAY	15,193.000	15,193.000
0158	643.0705	Traffic Control Warning Lights Type A	DAY	30,386.000	30,386.000
0160	643.0715	Traffic Control Warning Lights Type C	DAY	1,891.000	1,891.000
0162	643.0900	Traffic Control Signs	DAY	44,442.000	44,442.000
0164	643.0920	Traffic Control Covering Signs Type II	EACH	2.000	2.000
0166	643.1050	Traffic Control Signs PCMS	DAY	35.000	35.000
0168	643.3105	Temporary Marking Line Paint 4-Inch	LF	2,607.000	2,607.000
0170	643.3150	Temporary Marking Line Removable Tape 4-Inch	LF	3,286.000	3,286.000
0172	643.3760	Temporary Marking Raised Pavement Marker Type I	EACH	14.000	14.000
0174	643.3805	Temporary Marking Stop Line Paint 18-Inch	LF	44.000	44.000
0176	643.3850	Temporary Marking Stop Line Removable Tape 18-Inch	LF	88.000	88.000
0178	643.5000	Traffic Control	EACH	1.000	1.000
0180	644.1410	Temporary Pedestrian Surface Asphalt	SF	185.000	185.000
0182	644.1430	Temporary Pedestrian Surface Plate	SF	135.000	135.000
0184	644.1601	Temporary Pedestrian Curb Ramp	DAY	120.000	120.000
0186	644.1605	Temporary Pedestrian Detectable Warning Field	SF	230.000	230.000
0188	644.1810	Temporary Pedestrian Barricade	LF	4,656.000	4,656.000
0190	645.0111	Geotextile Type DF Schedule A	SY	277.000	277.000
0192	646.1020	Marking Line Epoxy 4-Inch	LF	13,771.000	13,771.000
0194	646.3020	Marking Line Epoxy 8-Inch	LF	580.000	580.000
0196	646.5020	Marking Arrow Epoxy	EACH	28.000	28.000
0198	646.5120	Marking Word Epoxy	EACH	2.000	2.000
0200	646.5220	Marking Symbol Epoxy	EACH	18.000	18.000

Estimate Of Quantities

2230-07-73

Line	Item	Item Description	Unit	Total	Qty
0202	646.6120	Marking Stop Line Epoxy 18-Inch	LF	287.000	287.000
0204	646.7020	Marking Diagonal Epoxy 6-Inch	LF	110.000	110.000
0206	646.7120	Marking Diagonal Epoxy 12-Inch	LF	184.000	184.000
0208	646.7420	Marking Crosswalk Epoxy Transverse Line 6-Inch	LF	1,576.000	1,576.000
0210	646.7520	Marking Crosswalk Epoxy Block Style 24-Inch	LF	505.000	505.000
0212	646.9010	Marking Removal Line Water Blasting 4-Inch	LF	1,574.000	1,574.000
0214	646.9110	Marking Removal Line Water Blasting 8-Inch	LF	656.000	656.000
0216	646.9210	Marking Removal Line Water Blasting Wide	LF	20.000	20.000
0218	646.9310	Marking Removal Special Marking Water Blasting	EACH	1.000	1.000
0220	650.4000	Construction Staking Storm Sewer	EACH	42.000	42.000
0222	650.4500	Construction Staking Subgrade	LF	2,906.000	2,906.000
0224	650.5500	Construction Staking Curb Gutter and Curb & Gutter	LF	7,471.000	7,471.000
0226	650.7000	Construction Staking Concrete Pavement	LF	2,906.000	2,906.000
0228	650.8501	Construction Staking Electrical Installations (project) 01. 2230-07-73	EACH	1.000	1.000
0230	650.9000	Construction Staking Curb Ramps	EACH	56.000	56.000
0232	650.9500	Construction Staking Sidewalk (project) 01. 2230-07-73	EACH	1.000	1.000
0234	650.9911	Construction Staking Supplemental Control (project) 01. 2230-07-73	EACH	1.000	1.000
0236	650.9920	Construction Staking Slope Stakes	LF	2,906.000	2,906.000
0238	652.0225	Conduit Rigid Nonmetallic Schedule 40 2-Inch	LF	8,913.000	8,913.000
0240	652.0235	Conduit Rigid Nonmetallic Schedule 40 3-Inch	LF	1,152.000	1,152.000
0242	653.0135	Pull Boxes Steel 24x36-Inch	EACH	22.000	22.000
0244	653.0140	Pull Boxes Steel 24x42-Inch	EACH	9.000	9.000
0246	653.0905	Removing Pull Boxes	EACH	28.000	28.000
0248	654.0101	Concrete Bases Type 1	EACH	7.000	7.000
0250	654.0102	Concrete Bases Type 2	EACH	2.000	2.000
0252	654.0105	Concrete Bases Type 5	EACH	23.000	23.000
0254	654.0110	Concrete Bases Type 10	EACH	2.000	2.000
0256	654.0120	Concrete Bases Type 10-Special	EACH	2.000	2.000
0258	654.0217	Concrete Control Cabinet Bases Type 9 Special	EACH	1.000	1.000
0260	654.0230	Concrete Control Cabinet Bases Type L30	EACH	1.000	1.000
0262	655.0230	Cable Traffic Signal 5-14 AWG	LF	965.000	965.000
0264	655.0240	Cable Traffic Signal 7-14 AWG	LF	125.000	125.000
0266	655.0260	Cable Traffic Signal 12-14 AWG	LF	745.000	745.000
0268	655.0270	Cable Traffic Signal 15-14 AWG	LF	1,157.000	1,157.000
0270	655.0320	Cable Type UF 2-10 AWG Grounded	LF	794.000	794.000
0272	655.0515	Electrical Wire Traffic Signals 10 AWG	LF	1,335.000	1,335.000
0274	655.0610	Electrical Wire Lighting 12 AWG	LF	3,821.000	3,821.000
0276	655.0625	Electrical Wire Lighting 6 AWG	LF	34,426.000	34,426.000
0278	655.0900	Traffic Signal EVP Detector Cable	LF	816.000	816.000
0280	656.0201	Electrical Service Meter Breaker Pedestal (location) 01. W Greenfield & Beloit Rd - Signal	EACH	1.000	1.000
0282	656.0201	Electrical Service Meter Breaker Pedestal (location) 02. W Greenfield Ave & W Beloit Rd - Lighting	EACH	1.000	1.000
0284	657.0100	Pedestal Bases	EACH	7.000	7.000
0286	657.0255	Transformer Bases Breakaway 11 1/2-Inch Bolt Circle	EACH	2.000	2.000
0288	657.0310	Poles Type 3	EACH	2.000	2.000
0290	657.0350	Poles Type 10	EACH	2.000	2.000
0292	657.0352	Poles Type 10-Special	EACH	2.000	2.000
0294	657.0420	Traffic Signal Standards Aluminum 13-FT	EACH	1.000	1.000
0296	657.0425	Traffic Signal Standards Aluminum 15-FT	EACH	6.000	6.000
0298	657.0520	Monotube Arms 20-FT	EACH	1.000	1.000

Estimate Of Quantities

2230-07-73

Line	Item	Item Description	Unit	Total	Qty
0300	657.0530	Monotube Arms 30-FT	EACH	1.000	1.000
0302	657.0536	Monotube Arms 35-FT-Special	EACH	2.000	2.000
0304	657.0614	Luminaire Arms Single Member 4-Inch Clamp 8-FT	EACH	2.000	2.000
0306	657.0812	Luminaire Arms Steel 12-FT	EACH	4.000	4.000
0308	658.0173	Traffic Signal Face 3S 12-Inch	EACH	13.000	13.000
0310	658.0174	Traffic Signal Face 4S 12-Inch	EACH	4.000	4.000
0312	658.0416	Pedestrian Signal Face 16-Inch	EACH	8.000	8.000
0314	658.5070	Signal Mounting Hardware (location) 01. W Greenfield Ave & W Beloit Rd	EACH	1.000	1.000
0316	659.2230	Lighting Control Cabinets 240/480 30-Inch	EACH	1.000	1.000
0318	690.0150	Sawing Asphalt	LF	454.000	454.000
0320	690.0250	Sawing Concrete	LF	4,151.000	4,151.000
0322	715.0720	Incentive Compressive Strength Concrete Pavement	DOL	4,425.000	4,425.000
0324	999.1501.S	Crack and Damage Survey	EACH	3.000	3.000
0326	ASP.1T0A	On-the-Job Training Apprentice at \$5.00/HR	HRS	6,000.000	6,000.000
0328	ASP.1T0G	On-the-Job Training Graduate at \$5.00/HR	HRS	4,500.000	4,500.000
0330	SPV.0035	Special 01. Backfill for Plant Beds, 24-Inch	CY	25.000	25.000
0332	SPV.0060	Special 01. Emergency Vehicle Preemption System	EACH	1.000	1.000
0334	SPV.0060	Special 02. APS Push Button System, 4 Buttons, W Greenfield Ave & S 52nd St	EACH	1.000	1.000
0336	SPV.0060	Special 03. APS Push Button System, 4 Buttons, W Greenfield Ave & S 51st St	EACH	1.000	1.000
0338	SPV.0060	Special 04. APS Push Button System, 8 Buttons, W Greenfield Ave & W Beloit Rd	EACH	1.000	1.000
0340	SPV.0060	Special 05. Traffic Signal Controller & Cabinet	EACH	1.000	1.000
0342	SPV.0060	Special 06. Video Vehicle Detection system, W Greenfield Ave & W Beloit Rd	EACH	1.000	1.000
0344	SPV.0060	Special 07. Rectangular Rapid Flashing Beacon System, W Greenfield Ave & S 52nd St	EACH	1.000	1.000
0346	SPV.0060	Special 08. Rectangular Rapid Flashing Beacon System, W Greenfield Ave & S 51st St	EACH	1.000	1.000
0348	SPV.0060	Special 09. 240/120V Transformer	EACH	5.000	5.000
0350	SPV.0060	Special 10. Temporary Lighting System	EACH	1.000	1.000
0352	SPV.0060	Special 11. Light Pole Special	EACH	27.000	27.000
0354	SPV.0060	Special 12. Luminaire	EACH	35.000	35.000
0356	SPV.0060	Special 13. Luminaire Arms 8-Foot, Special	EACH	29.000	29.000
0358	SPV.0060	Special 14. Transformer Bases Breakaway 11 1/2-Inch Bolt Circle, Special	EACH	5.000	5.000
0360	SPV.0060	Special 15. Temporary Pipe Connection 12-Inch	EACH	1.000	1.000
0362	SPV.0060	Special 16. Round Steel Sign Post System	EACH	53.000	53.000
0364	SPV.0060	Special 17. Utility Line Opening	EACH	16.000	16.000
0366	SPV.0060	Special 18. Section Corner Monuments	EACH	2.000	2.000
0368	SPV.0060	Special 19. Adjust Sanitary Sewer Manhole	EACH	11.000	11.000
0370	SPV.0060	Special 20. Internal Sanitary Manhole Seal	EACH	11.000	11.000
0372	SPV.0060	Special 21. Adjust Water Valve Boxes	EACH	72.000	72.000
0374	SPV.0060	Special 22. Stone Veneer Seat Wall Planter, Sta. 48+15	EACH	1.000	1.000
0376	SPV.0060	Special 23. Stone Veneer Seat Wall Planter, Sta. 48+81	EACH	1.000	1.000
0378	SPV.0090	Special 01. Concrete curb & Gutter 30-Inch Type A Special	LF	42.000	42.000

CLEARING & GRUBBING

STATION TO STATION	201.0120	201.0220
	CLEARING	GRUBBING
	ID	ID
<u>W GREENFIELD AVE</u>		
23+81 LT	36	36
24+06 LT	32	32
43+00 LT	32	32
TOTALS	100	100

REMOVING CONCRETE PAVEMENT

204.0100
REMOVING
CONCRETE
PAVEMENT

STATION TO STATION	SY
<u>W GREENFIELD AVE - WB</u>	
23+00 - 32+00	2,828
32+00 - 42+00	3,349
42+00 - 50+00	4,054
<u>W GREENFIELD AVE - EB</u>	
23+00 - 32+00	2,203
32+00 - 42+00	2,553
42+00 - 50+00	2,564
TOTALS	17,551

REMOVING ASPHALTIC SURFACE BUTT JOINTS

204.0115
REMOVING
ASPHALTIC SURFACE
BUTT JOINTS

STATION TO STATION	SY
<u>W GREENFIELD AVE - EB</u>	
23+00 - 32+00	20
32+00 - 42+00	6
42+00 - 50+00	9
<u>W GREENFIELD AVE - WB</u>	
23+00 - 32+00	17
32+00 - 42+00	12
42+00 - 50+00	15
TOTALS	79

REMOVING ASPHALTIC SURFACE MILLING

204.0120
REMOVING
ASPHALTIC SURFACE
MILLING

STATION TO STATION	SY
<u>W GREENFIELD AVE - EB</u>	
23+00 - 32+00	98
32+00 - 42+00	29
42+00 - 50+00	45
<u>W GREENFIELD AVE - WB</u>	
23+00 - 32+00	76
32+00 - 42+00	58
42+00 - 50+00	73
TOTALS	379

REMOVING CONCRETE SIDEWALK

204.0155
REMOVING
CONCRETE

STATION TO STATION	SY
<u>W GREENFIELD AVE - EB</u>	
23+00 - 32+00	664
32+00 - 42+00	762
42+00 - 50+00	660
<u>W GREENFIELD AVE - WB</u>	
23+00 - 32+00	692
32+00 - 42+00	1,011
42+00 - 50+00	545
TOTALS	4,334

3

3

<u>REMOVING INLETS</u>		204.0220
REMOVING INLETS		
STATION	EACH	
<u>W GREENFIELD AVE</u>		
26+04, 21' LT	1	
26+04, 21' RT	1	
26+22, 40' RT	1	
26+48, 40' RT	1	
29+12, 21' LT	1	
29+12, 21' RT	1	
29+31, 40' LT	1	
29+31, 40' RT	1	
29+58, 40' LT	1	
29+57, 40' RT	1	
30+42, 21' LT	1	
30+66, 21' RT	1	
32+09, 21' LT	1	
32+09, 21' RT	1	
32+28, 39' LT	1	
32+28, 36' RT	1	
32+54, 37' LT	1	
32+53, 40' RT	1	
35+07, 21' LT	1	
35+07, 21' RT	1	
35+23, 37' LT	1	
35+25, 40' RT	1	
35+53, 36' LT	1	
35+51, 40' RT	1	
37+68, 21' RT	1	
37+92, 40' RT	1	
37+99, 21' LT	1	
38+17, 40' RT	1	
39+43, 21' RT	1	
39+47, 21' LT	1	
39+53, 21' RT	1	
39+57, 21' LT	1	
40+77, 21' RT	1	
41+09, 21' LT	1	
42+85, 150' RT	1	
45+83, 32' LT	1	
46+75, 29' RT	1	
48+60, 36' LT	1	
TOTALS		38

<u>REMOVING MANHOLES</u>		204.0210
REMOVING MANHOLES		
STATION	EACH	
<u>W GREENFIELD AVE</u>		
29+38, 40' LT	1	
29+69, 41' LT	1	
TOTALS		2

<u>REMOVING CONCRETE FENCE BASES</u>		204.9060.S.02
REMOVING CONCRETE FENCE BASES		
STATION TO STATION	EACH	
<u>W GREENFIELD AVE</u>		
39+97 LT	1	
TOTALS		1

<u>REMOVING & ABANDONING STORM SEWER</u>		
STATION TO STATION	LF	CY
<u>W GREENFIELD AVE</u>		
23+00 - 32+00	286	-
32+00 - 42+00	559	-
42+00 - 50+00	99	5
TOTALS		944

<u>REMOVING RAILING</u>		204.9060.S.03
REMOVING STEPS RAILING		
STATION TO STATION	EACH	
<u>GREENFIELD AVENUE</u>		
23+50 LT	1	
32+75 RT	1	
35+70 RT	1	
TOTALS		3

<u>REMOVING FLASHING BEACONS & MAST ARMS</u>		204.9060.S.01
REMOVING FLASHING BEACONS & MAST ARMS		
STATION TO STATION	EACH	
<u>W GREENFIELD AVE</u>		
35+01 RT	1	
39+39 LT	1	
TOTALS		2

<u>REMOVING CONCRETE STEPS</u>		204.9165.S
REMOVING CONCRETE STEPS		
STATION TO STATION	SF	
<u>W GREENFIELD AVE - EB</u>		
23+00 - 32+00	-	
32+00 - 42+00	63	
42+00 - 50+00	-	
<u>W GREENFIELD AVE - WB</u>		
23+00 - 32+00	-	
32+00 - 42+00	14	
42+00 - 50+00	14	
TOTALS		91

3

3

DIVISION	FROM/TO STATION	LOCATION	205.0100 COMMON EXCAVATION (1)		SALVAGED/UNUSABLE PAVEMENT MATERIAL (4)	AVAILABLE MATERIAL (5)	UNEXPANDED FILL	EXPANDED FILL (13)	MASS ORDINATE +/- (14)	WASTE	208.0100 BORROW	COMMENT
			CUT (2)	EBS EXCAVATION (3)				FACTOR 1.15				
DIVISION 1												
GREENFIELD WEST	23+50/49+75		15,751	0	4,003	11,748	2	2	11,746	11,746	0	
BELOIT	504+00/507+25		1,170	0	294	876	0	0	876	876	0	
UNDISTRIBUTED			0	1,000	0	1,000	0	0	1,000	1,000	0	
DIVISION 1 SUBTOTAL			16,921	1,000	4,297	13,624	2	2	13,622	13,622	0	0
GRAND TOTAL			16,921	1,000	4,297	13,624	2	2	13,622	13,622	0	
TOTAL COMMON EXC			17,921									

NOTES:

- (1) COMMON EXCAVATION IS THE SUM OF THE CUT AND EBS EXCAVATION COLUMNS. ITEM NUMBER 205.0100
- (2) SALVAGED/UNUSABLE PAVEMENT MATERIAL IS INCLUDED IN CUT.
- (3) EBS EXCAVATION TO BE BACKFILLED WITH BREAKER RUN.
- (4) SALVAGED/UNUSABLE PAVEMENT MATERIAL
- (5) AVAILABLE MATERIAL = CUT - SALVAGED/UNUSABLE PAVEMENT MATERIAL
- (13) EXPANDED FILL FACTOR = 1.15
- (14) THE MASS ORDINATE + OR - QTY CALCULATED FOR THE DIVISION. PLUS QUANTITY INDICATES AN EXCESS OF MATERIAL WITHIN THE DIVISION. MINUS INDICATES A SHORTAGE OF MATERIAL WITHIN THE DIVISION.

FINISHING ROADWAY

213.0100
FINISHING ROADWAY

PROJECT	EACH
ID 2230-07-73	1
	1

3

3

BASE AGGREGATE DENSE 1 1/4-INCH

305.0120
BASE AGGREGATE
DENSE 1 1/4-INCH

STATION TO STATION	TON
<u>W GREENFIELD AVE - EB</u>	
23+00 - 32+00	1,072
32+00 - 42+00	1,230
42+00 - 50+00	1,316
<u>W GREENFIELD AVE - WB</u>	
23+00 - 32+00	1,056
32+00 - 42+00	1,227
42+00 - 50+00	1,238
<u>W GREENFIELD AVE</u>	
UNDISTRIBUTED - DRIVEWAYS	600
TOTALS	7,739

BREAKER RUN

311.0110
BREAKER RUN

STATION TO STATION	TON
<u>W GREENFIELD AVE - EB</u>	
23+00 - 32+00	2,129
32+00 - 42+00	2,475
42+00 - 50+00	2,728
UNDISTRIBUTED	900
<u>W GREENFIELD AVE - WB</u>	
23+00 - 32+00	2,124
32+00 - 42+00	2,472
42+00 - 50+00	2,380
UNDISTRIBUTED	900
TOTALS	16,108

COLORED CONCRETE

405.0100
COLORED
CONCRETE
WISDOT RED

STATION TO STATION	CY
<u>W GREENFIELD AVE</u>	
23+00 - 32+00	-
32+00 - 42+00	3
42+00 - 50+00	40
TOTALS	43

CONCRETE PAVEMENT

415.0080
8-INCH
415.4100
JOINT FILLING

STATION TO STATION	SY	SY
<u>W GREENFIELD AVE - EB</u>		
23+00 - 32+00	2,208	2,208
32+00 - 42+00	2,559	2,559
42+00 - 50+00	2,839	2,839
<u>W GREENFIELD AVE - WB</u>		
23+00 - 32+00	2,196	2,196
32+00 - 42+00	2,561	2,561
42+00 - 50+00	2,387	2,387
TOTALS	14,750	14,750

CONCRETE PAVEMENT GAPS

415.0210
CONCRETE
PAVEMENT GAPS

STATION	EACH
<u>W GREENFIELD AVE</u>	
STAGE 1	
29+45 LT	1
35+40 LT	1
STAGE 2	
29+45 RT	1
35+40 RT	1
TOTALS	4

DRILLED TIE BARS

416.0610
DRILLED TIE BARS

STATION TO STATION	EACH
<u>W GREENFIELD AVE - EB</u>	
23+00 - 32+00	7
32+00 - 42+00	-
42+00 - 50+00	-
<u>W GREENFIELD AVE - WB</u>	
23+00 - 32+00	7
32+00 - 42+00	-
42+00 - 50+00	-
TOTALS	14

3

3

<u>DRILLED DOWEL BARS</u>	
STATION TO STATION	416.0620 DRILLED DOWEL BARS EACH
W GREENFIELD AVE - EB	
23+00 - 32+00	54
32+00 - 42+00	62
42+00 - 50+00	47
W GREENFIELD AVE - WB	
23+00 - 32+00	34
32+00 - 42+00	62
42+00 - 50+00	67
TOTALS	326

<u>HMA PAVEMENT</u>				
STATION TO STATION	455.0605 TACK COAT GAL	460.5224 4 LT 58-28 S TON	465.0120 DRIVEWAYS AND FIELD ENTRANCES TON	465.0125 ASPHALTIC SURFACE TEMPORARY TON
W GREENFIELD AVE - EB				
23+00 - 32+00	6	11	13	-
32+00 - 42+00	2	3	-	-
42+00 - 50+00	3	5	6	-
W GREENFIELD AVE - WB				
23+00 - 32+00	5	9	-	-
32+00 - 42+00	3	7	-	-
42+00 - 50+00	4	8	12	-
STAGING				
UNDISTRIBUTED	-	-	-	12
TOTALS	23	43	31	12

<u>STAIR RAILING</u>	
STATION TO STATION	513.2001 RAILING PIPE LF
STREET NAME	
23+50 LT	3
32+75 RT	5
35+70 RT	4
TOTALS	12

<u>CONCRETE CURB</u>	
STATION TO STATION	601.0600 PEDESTRIAN LF
W GREENFIELD AVE - EB	
23+00 - 32+00	16
32+00 - 42+00	24
42+00 - 50+00	-
W GREENFIELD AVE - WB	
23+00 - 32+00	8
32+00 - 42+00	9
42+00 - 50+00	-
TOTALS	57

<u>CONCRETE CURB & GUTTER</u>			
STATION TO STATION	601.0405 18-INCH TYPE A LF	601.0409 30-INCH TYPE A LF	SPV.0090.01 30-INCH TYPE A SPECIAL LF
W GREENFIELD AVE - EB			
23+00 - 32+00	-	925	-
32+00 - 42+00	29	1,018	42
42+00 - 50+00	655	969	-
W GREENFIELD AVE - WB			
23+00 - 32+00	-	928	-
32+00 - 42+00	28	1,049	-
42+00 - 50+00	420	854	-
TOTALS	1,132	5,743	42

<u>CONCRETE SIDEWALK</u>	
STATION TO STATION	602.0410 5-INCH SF
W GREENFIELD AVE - EB	
23+00 - 32+00	5,701
32+00 - 42+00	6,437
42+00 - 50+00	6,390
W GREENFIELD AVE - WB	
23+00 - 32+00	5,952
32+00 - 42+00	7,119
42+00 - 50+00	5,344
TOTALS	36,943

3

CURB RAMP DETECTABLE WARNING FIELD YELLOW
602.0505
CURB RAMP DETECTABLE
WARNING FIELD YELLOW

STATION TO STATION	SF
W GREENFIELD AVE	
23+00 - 32+00	180
32+00 - 42+00	220
42+00 - 50+00	87
TOTALS	487

CONCRETE DRIVEWAY
602.0815
7-INCH
SY

STATION TO STATION	SY
W GREENFIELD AVE - EB	
23+00 - 32+00	75
32+00 - 42+00	119
42+00 - 50+00	40
W GREENFIELD AVE - WB	
23+00 - 32+00	73
32+00 - 42+00	64
42+00 - 50+00	292
TOTALS	663

CONCRETE STEPS
602.1500
CONCRETE STEPS

STATION TO STATION	SF
W GREENFIELD AVE - EB	
23+00 - 32+00	-
32+00 - 42+00	63
42+00 - 50+00	-
W GREENFIELD AVE - WB	
23+00 - 32+00	-
32+00 - 42+00	14
42+00 - 50+00	14
TOTALS	91

3

PIPE UNDERDRAIN
310.0110
BASE AGGREGATE
OPEN GRADED
612.0106
PIPE UNDERDRAIN
6-INCH
645.0111
GEOTEXTILE TYPE DF
SCHEDULE A

STATION TO STATION	TON	LF	SY
W GREENFIELD AVE - EB			
23+00 - 32+00	10	110	61
32+00 - 42+00	14	150	83
42+00 - 50+00	2	20	11
W GREENFIELD AVE - WB			
23+00 - 32+00	7	80	44
32+00 - 42+00	12	130	72
42+00 - 50+00	1	10	6
TOTALS	46	500	277

INSULATION BOARD POLYSTYRENE 3-INCH
612.0902.S
INSULATION BOARD
POLYSTYRENE 3-
INCH
SY

STATION TO STATION	SY
W GREENFIELD AVE - WB	
23+00 - 32+00	0.9
32+00 - 42+00	2.2
42+00 - 50+00	-
W GREENFIELD AVE - EB	
23+00 - 32+00	0.9
32+00 - 42+00	1.3
42+00 - 50+00	-
TOTALS	5.3

MOBILIZATION
619.1000
PROJECT
EACH

ID 2230-70-73	1
TOTALS	1

CONCRETE MEDIAN NOSE
620.0300
SLOPED NOSE
SF

STATION TO STATION	SF
W GREENFIELD AVE	
41+70	24
43+45 RT	7
43+69 RT	10
43+88 LT	14
45+04 RT	25
48+26 LT	13
TOTALS	93

STORM SEWER PIPES						
608.0312			608.0315			
STORM SEWER PIPE REINFORCED			STORM SEWER PIPE REINFORCED			
CONCRETE CLASS III 12-INCH			CONCRETE CLASS III 15-INCH			
FROM - TO	LF		LF	INLET ELEVATION	DISCHARGE ELEVATION	SLOPE FT/FT
1A - 1	15			676.06	675.91	0.0102
2A - 2	5			666.10	666.05	0.0111
4A - 4B	27			667.79	666.80	0.0373
4B - 4	8			666.30	666.22	0.0100
4C - 4	21			666.33	666.22	0.0052
6A - 6	28			648.68	648.40	0.0101
7 - 6			21	646.14	646.03	0.0054
7A - 7	8			647.75	647.67	0.0103
7B - 7	21			646.86	646.64	0.0103
7C - 7B	11			647.04	646.96	0.0074
8A - 8	26			648.53	646.95	0.0609
9A - 9	8			648.77	648.69	0.0101
9B - 9	21			649.37	649.15	0.0104
10A - 10	35			646.37	645.97	0.0113
10B - 10A	10			646.62	646.57	0.0050
10C - 10	12			646.81	646.73	0.0068
10D - 10C	10			647.06	647.01	0.0050
12A - 12	7			645.12	645.05	0.0102
12B - 12	22			645.98	645.05	0.0420
14A - 14	8			645.07	644.91	0.0208
14B - 14	21			646.79	646.50	0.0136
15A - 15B	29			644.18	644.04	0.0049
15B - 15	21			643.63	643.28	0.0164
15C - 15	8			643.42	643.34	0.0105
17A - 17B	24			644.03	643.58	0.0187
17B - 17	9			643.06	642.88	0.0197
17C - 17	21			643.46	642.88	0.0272
20A - 20	23			640.72	640.61	0.0048
22A - 22B	25			640.85	640.41	0.0175
22B - 22	8			640.31	640.23	0.0102
22C - 22	22			640.23	640.06	0.0076
23A - 23	12			638.50	637.45	0.0876
23B - 23A	10			638.90	638.60	0.0300
24A - 24	33			640.14	639.75	0.0119
24B - 24A	8			640.53	640.45	0.0100
26A - 26	13			639.50	637.70	0.1402
27A - 27	26			639.95	639.69	0.0100
36A - 36	14			646.21	645.27	0.0672
38A - 38	24			645.34	643.04	0.0965
39A - 39	26			647.13	647.00	0.0050
67A - 67	10			642.71	642.61	0.0100
TOTALS	690		21			

STORM SEWER STRUCTURES

STRUCTURE	STATION	OFFSET*	611.0530	611.0624	611.0639	611.0648	611.0651	611.1003	611.1230	611.2004	611.8110	650.4000	RIM** ELEVATION	INVERT*** ELEVATION	DEPTH**** FT	COMMENTS
			MANHOLE COVERS TYPE J EACH	INLET COVERS TYPE H EACH	INLET COVERS TYPE H-S EACH	INLET COVERS TYPE R EACH	INLET COVERS TYPE S EACH	CATCH BASINS 3-FT DIAMETER EACH	CATCH BASINS 2X3-FT EACH	MANHOLES 4- FT DIAMETER EACH	ADJUSTING MANHOLE COVERS EACH	CONSTRUCTION STAKING STORM SEWER EACH				
1	23+33.00	19.02' RT	1							1		1	680.21	675.25	3.91	
1A	23+30.78	33.50' RT				1		1				1	680.06	676.06	2.83	R-1
2	25+99.95	28.01' LT									1		672.67	--	--	
2A	26+00.00	23.50' LT		1				1				1	672.18	664.10	7.08	
3	26+29.34	28.13' LT									1		671.09	--	--	
4	26+28.47	40.28' RT									1		671.50	--	--	
4A	26+04.00	17.50' RT		1				1				1	672.29	665.79	5.50	
4B	26+20.84	38.00' RT			1			1				1	671.29	664.30	5.99	
4C	26+49.81	40.00' RT		1				1				1	670.99	664.33	5.66	
5	27+48.92	27.60' LT									1		665.54	--	--	
6	29+38.50	28.50' LT									1		652.58	--	--	
6A	29+13.00	17.50' LT		1				1				1	653.81	646.68	6.13	
7	29+38.09	49.00' LT	1							1		1	651.13	644.64	5.25	
7A	29+30.45	50.30' LT			1			1				1	650.81	645.75	4.06	
7B	29+59.44	50.00' LT			1			1				1	650.75	644.86	4.89	
7C	29+69.51	54.00' LT	1							1		1	651.46	647.04	3.34	
8	29+38.12	10.97' RT									1		653.53	--	--	
8A	29+13.00	17.50' RT		1				1				1	654.53	646.53	7.00	
9	29+37.55	40.26' RT									1		653.93	--	--	
9A	29+29.80	38.50' RT			1			1				1	653.73	646.77	5.96	
9B	29+58.78	40.00' RT		1				1				1	653.59	647.37	5.22	
10	30+41.12	11.78' RT									1		652.01	--	--	
10A	30+40.00	23.50' LT		1				1				1	650.99	644.37	5.62	
10B	30+50.00	23.50' LT			1			1				1	650.87	644.62	5.25	
10C	30+40.00	23.50' RT		1				1				1	651.90	644.81	6.09	
10D	30+50.00	23.50' RT			1			1				1	651.75	645.06	5.69	
11	32+36.81	5.95' RT									1		652.23	--	--	
12	32+34.10	40.49' LT									1		650.96	--	--	
12A	32+27.25	40.00' LT			1			1				1	650.76	643.12	6.64	
12B	32+56.25	40.00' LT			1			1				1	651.08	643.98	6.10	
13	32+36.35	11.52' RT									1		652.20	--	--	
14	32+34.33	40.49' RT									1		652.02	--	--	
14A	32+26.66	40.00' RT			1			1				1	651.76	643.07	7.69	
14B	32+55.70	40.00' RT			1			1				1	651.70	644.79	5.91	
15	35+45.20	40.40' LT									1		647.75	--	--	
15A	35+06.00	17.50' LT		1				1				1	648.68	642.18	5.50	
15B	35+23.81	40.00' LT			1			1				1	647.62	641.63	4.99	
15C	35+52.81	40.00' LT			1			1				1	647.55	641.42	5.13	
16	35+32.20	5.52' RT									1		648.53	--	--	
17	35+31.22	40.03' RT									1		648.87	--	--	
17A	35+07.00	17.50' RT		1				1				1	648.66	642.03	5.63	
17B	35+23.58	35.00' RT			1			1				1	648.32	641.06	6.26	
17C	35+52.54	40.00' RT		1				1				1	648.65	641.46	6.19	
18	35+41.53	10.28' RT									1		648.31	--	--	
19	35+52.41	6.83' RT									1		648.24	--	--	
20	37+98.18	5.35' RT									1		645.57	--	--	
20A	37+98.00	17.50' LT		1				1				1	645.24	638.72	5.52	
21	37+98.34	10.88' RT									1		645.46	--	--	
22	37+96.56	40.35' RT									1		645.56	--	--	
22A	37+73.00	17.50' RT		1				1				1	645.54	638.85	5.69	

3

3

STORM SEWER STRUCTURES

STRUCTURE	STATION	OFFSET*	611.0530	611.0624	611.0639	611.0648	611.0651	611.1003	611.1230	611.2004	611.8110	650.4000	RIM** ELEVATION	INVERT*** ELEVATION	DEPTH**** FT	COMMENTS
			MANHOLE	INLET COVERS	INLET COVERS	INLET COVERS	INLET COVERS	CATCH BASINS	CATCH BASINS	MANHOLES 4-	ADJUSTING	CONSTRUCTION				
			COVERS TYPE J EACH	TYPE H EACH	TYPE H-S EACH	TYPE R EACH	TYPE S EACH	3-FT DIAMETER EACH	2X3-FT EACH	FT DIAMETER EACH	MANHOLE COVERS EACH	STAKING STORM SEWER EACH				
22B	37+90.05	36.00' RT			1				1			1	645.24	638.31	5.93	
22C	38+19.02	40.00' RT		1					1			1	645.39	638.23	6.16	
23	39+40.18	11.85' RT									1		644.75	--	--	
23A	39+43.00	23.50' RT			1				1			1	644.24	636.50	6.74	
23B	39+53.00	23.50' RT			1				1			1	644.15	636.90	6.25	
24	39+63.61	6.81' RT									1		644.81	--	--	
24A	39+71.00	25.00' LT			1				1			1	644.03	638.14	4.89	
24B	39+79.00	25.00' LT			1				1			1	644.02	638.53	4.49	
25	40+70.35	6.93' RT									1		645.03	--	--	
26	40+70.66	11.83' RT									1		644.95	--	--	
26A	40+76.00	23.50' RT		1					1			1	644.75	637.50	6.25	
27	41+15.87	7.04' RT									1		645.66	--	--	
27A	41+11.00	18.54' LT		1					1			1	645.10	637.95	6.15	
28	43+53.77	47.89' RT									1		652.61	--	--	
29	43+32.39	12.60' RT									1		651.60	--	--	
30	43+85.01	32.41' LT									1		652.38	--	--	
31	43+60.65	6.05' RT									1		652.40	--	--	
32	44+77.84	14.53' LT									1		653.26	--	--	
33	43+73.52	63.53' RT									1		652.71	--	--	
34	44+77.69	30.00' RT									1		653.51	--	--	
35	44+82.06	11.67' RT									1		653.36	--	--	
36	45+81.80	11.76' LT									1		652.77	--	--	
36A	45+82.00	25.75' LT				1		1				1	652.51	644.21	6.97	R-P
37	46+96.81	6.31' LT									1		651.91	--	--	
38	46+94.13	11.17' RT									1		651.94	--	--	
38A	46+77.00	27.75' RT				1		1				1	651.78	643.34	7.11	R-P
39	48+57.19	12.04' LT									1		650.36	--	--	
39A	48+60.00	38.00' LT					1	1				1	650.42	645.13	4.29	
67A	42+84.95	150.30' RT		1					1			1	651.70	640.71	9.99	
			3	17	18	3	1	4	35	3	37	42				

REMARKS:

*STATIONS AND OFFSETS ARE TO CENTER OF STRUCTURE

**RIM ELEV IS AT THE INLET COVER FLANGE LOCATION

***FOR STRUCTURES WITH SUMPS, THE INVERT ELEVATION IS THE ELEVATION OF THE SUMP. FOR STRUCTURES WITHOUT SUMPS, THE INVERT ELEVATION IS THE ELEVATION OF THE LOWEST PIPE FLOW LINE

****DEPTH = RIM ELEV - TOP OF STRUCTURE BASE ELEV - COVER HEIGHT - 6-INCH ADJUSTMENT RING HEIGHT

3

<u>WATER</u>		624.0100
		WATER
PROJECT		MGAL
ID 2230-07-73		111
TOTALS		111

<u>EROSION CONTROL MOBILIZATIONS</u>		
	628.1905	628.1910
	MOBILIZATIONS	MOBILIZATIONS
	EROSION CONTROL	EMERGENCY
		EROSION CONTROL
PROJECT	EACH	EACH
ID 2230-07-73	3	3
TOTALS		3

3

<u>TOPSOIL</u>		625.0100
		TOPSOIL
STATION TO STATION		SY
<u>W GREENFIELD AVE</u>		
23+00 - 32+00		575
32+00 - 42+00		975
42+00 - 50+00		486
TOTALS		2,036

<u>TRACKING PADS</u>		628.7560
		TRACKING PADS
STATION TO STATION		EACH
<u>W GREENFIELD AVE</u>		
23+00 - 32+00		1
32+00 - 42+00		-
42+00 - 50+00		1
TOTALS		2

<u>INLET PROTECTION</u>				
	628.7005	628.7010	628.7015	628.7020
	INLET PROTECTION	INLET PROTECTION	INLET PROTECTION	INLET PROTECTION
	TYPE A	TYPE B	TYPE C	TYPE D
STATION TO STATION	EACH	EACH	EACH	EACH
<u>W GREENFIELD AVE</u>				
23+00 - 32+00	14	-	22	6
32+00 - 42+00	16	-	31	5
42+00 - 50+00	4	1	12	-
TOTALS	34	1	65	11

<u>SOD</u>			
	629.0210	631.0300	631.1000
	FERTILIZER TYPE B	SOD WATER	SOD LAWN
STATION TO STATION	CWT	MGAL	SY
<u>W GREENFIELD AVE</u>			
23+00 - 32+00	0.4	26	575
32+00 - 42+00	0.6	44	975
42+00 - 50+00	0.3	22	486
TOTALS	1.3	92	2036

TYPE II PERMANENT SIGNING

2230-07-73 W GREENFIELD AVENUE

SIGN NO.	SIGN CODE & SIZE	SIGN TYPE	SIGN MESSAGE	TYPE II SIGN SIZE			637.2210	637.2215	637.2220	637.2230	638.2102	638.2602	638.3000	SPV.0060.16	REMARKS / NEW SIGN LOCATION
				W [IN.]	x H [IN.]	H [SF]	SIGNS TYPE II REFLC H [SF]	SIGNS TYPE II REFLC H FOLDING [SF]	SIGNS TYPE II REFLC SH [SF]	SIGNS TYPE II REFLC F [SF]	MOVING SIGNS TYPE II [EA]	REMOVING SIGNS TYPE II [EA]	REMOVING SMALL SIGN SUPPORTS [EA]	ROUND STEEL SIGN POST SYSTEM [EA]	
1-1	D1-1	--	S 56TH ST	--	x	--	--	--	--	--	1	--	--	--	--
	D1-1	--	W GREENFIELD AVE	--	x	--	--	--	--	--	1	--	--	--	--
	R3-17	II	--	30	x	24	5.00	--	--	--	--	--	1	--	--
	R3-17BP	II	--	30	x	12	2.50	--	--	--	--	--	--	--	--
1-2	R-7 (SPECIAL)	--	WEST ALLIS NO PARKING	--	x	--	--	--	--	1	--	--	--	--	ON LIGHT POLE
1-3	R7-1D	II	--	18	x	24	3.00	--	--	--	1	1	--	--	--
1-4	R7-1	--	--	--	x	--	--	--	--	--	1	--	--	--	--
1-5	R7-8R	II	--	18	x	24	3.00	--	--	--	1	1	1	--	--
1-6	R7-8L	II	--	18	x	24	3.00	--	--	--	1	1	1	--	--
1-7	R7 (SPECIAL)	--	--	--	x	--	--	--	--	1	--	--	--	--	ON LIGHT POLE
1-8	D1-1	--	S 56TH ST	--	x	--	--	--	--	1	--	--	--	--	--
	D1-1	--	W GREENFIELD AVE	--	x	--	--	--	--	1	--	--	--	--	--
	R1-1	--	--	--	x	--	--	--	--	--	1	1	--	--	--
	R1-1	II	--	30	x	30	5.18	--	--	--	--	--	1	--	--
1-9	R7 (SPECIAL)	--	--	--	x	--	--	--	--	2	--	--	--	--	ON LIGHT POLE
1-10	R7-1	--	--	--	x	--	--	--	--	--	1	1	--	--	--
1-11	R3-2	II	--	24	X	24	4.00	--	--	--	1	--	1	--	--
1-12	R5-2	II	--	24	x	24	4.00	--	--	--	1	1	1	--	--
1-13	D1-1	--	S 55TH ST	--	x	--	--	--	--	1	--	--	--	--	--
	D1-1	--	W GREENFIELD AVE	--	x	--	--	--	--	1	--	--	--	--	--
	R1-1	--	--	--	x	--	--	--	--	--	1	1	--	--	--
	R1-1	II	--	30	x	30	5.18	--	--	--	--	--	1	--	--
2-1	D1-1	--	S 54TH ST	--	x	--	--	--	--	1	--	--	--	--	--
	D1-1	--	W GREENFIELD AVE	--	x	--	--	--	--	1	--	--	--	--	--
	R1-1	--	--	--	x	--	--	--	--	--	1	1	--	--	--
	R1-1	II	--	30	x	30	5.18	--	--	--	--	--	1	--	--
2-2	R5-2	II	--	24	x	24	4.00	--	--	--	1	1	1	--	--
2-3	R7-1	--	--	--	x	--	--	--	--	--	1	1	--	--	--
2-4	R7 (SPECIAL)	--	--	--	x	--	--	--	--	1	--	--	--	--	ON LIGHT POLE
	SS-2	II	--	24	x	30	5.00	--	--	--	--	--	--	--	ON LIGHT POLE
2-5	R7 (SPECIAL)	--	--	--	x	--	--	--	--	1	--	--	--	--	ON LIGHT POLE
2-6	R7-1	--	--	--	x	--	--	--	--	--	1	1	--	--	--

3

3

TYPE II PERMANENT SIGNING

2230-07-73 W GREENFIELD AVENUE

SIGN NO.	SIGN CODE & SIZE	SIGN TYPE	SIGN MESSAGE	TYPE II SIGN SIZE			637.2210	637.2215	637.2220	637.2230	638.2102	638.2602	638.3000	SPV.0060.16	REMARKS / NEW SIGN LOCATION
				W [IN.]	x H [IN.]	H [SF]	SIGNS TYPE II REFLC H [SF]	SIGNS TYPE II REFLC SH [SF]	SIGNS TYPE II REFLC F [SF]	MOVING SIGNS TYPE II [EA]	REMOVING SIGNS TYPE II [EA]	REMOVING SMALL SIGN SUPPORTS [EA]	ROUND STEEL SIGN POST SYSTEM [EA]		
2-7	R5-2	II	--	24	x	24	4.00	--	--	--	--	1	1	1	--
2-8	D1-1	--	S 55TH ST	--	x	--	--	--	--	--	1	--	--	--	--
	D1-1	--	W GREENFIELD AVE	--	x	--	--	--	--	--	1	--	--	--	--
	R1-1	--	--	--	x	--	--	--	--	--	--	1	1	--	--
	R1-1	II	--	30	x	30	5.18	--	--	--	--	--	--	1	--
2-9	R7 (SPECIAL)	--	--	--	x	--	--	--	--	1	--	--	--	1	--
2-10	S1-1	II	--	36	x	36	--	--	--	6.75	--	1	--	1	--
	S16-9P	II	--	24	x	12	--	--	--	2.00	--	--	--	--	--
	R2-6P	II	--	24	x	18	3.00	--	--	--	--	--	--	--	--
3-1	D1-1	--	S 53RD ST	--	x	--	--	--	--	--	1	--	--	--	--
	D1-1	--	W GREENFIELD AVE	--	x	--	--	--	--	--	1	--	--	--	--
	R1-1	--	--	--	x	--	--	--	--	--	--	1	1	--	--
	R1-1	II	--	30	x	30	5.18	--	--	--	--	--	--	1	--
3-2	R5-2	II	--	24	x	24	4.00	--	--	--	--	1	1	1	--
3-3	R2-1	II	--	24	x	30	5.00	--	--	--	--	--	--	--	ON LIGHT POLE
3-4	R7-1	--	--	--	x	--	--	--	--	--	--	1	1	--	--
3-5	R2-1	--	--	--	x	--	--	--	--	--	--	1	--	--	--
	R7 (SPECIAL)	--	--	--	x	--	--	--	--	--	1	--	--	1	--
3-6	S5-2	--	--	--	x	--	--	--	--	--	--	1	--	--	--
3-7	S1-1	II	--	36	x	36	--	--	--	6.75	--	--	--	--	ON SIGNAL POLE
	S16-7R	II	--	24	x	12	--	--	--	2.00	--	--	--	--	ON SIGNAL POLE
3-8	S1-1	II	--	36	x	36	--	--	--	6.75	--	--	--	--	ON SIGNAL POLE
	S16-7L	II	--	24	x	12	--	--	--	2.00	--	--	--	--	ON SIGNAL POLE
	R10-3EL	II	--	9	x	15	0.94	--	--	--	--	--	--	--	ON SIGNAL POLE
3-9	D1-1	--	S 52ND ST	--	x	--	--	--	--	--	1	--	--	--	--
	D1-1	--	W GREENFIELD AVE	--	x	--	--	--	--	--	1	--	--	--	--
	R1-1	--	--	--	x	--	--	--	--	--	--	1	1	--	--
	R1-1	II	--	30	x	30	5.18	--	--	--	--	--	--	1	--
3-10	R5-2	II	--	24	x	24	4.00	--	--	--	--	1	1	1	--
3-11	S1-1	II	--	36	x	36	--	--	--	6.75	--	1	--	--	ON LIGHT POLE
	S16-7R	II	--	24	x	12	--	--	--	2.00	--	1	--	--	ON LIGHT POLE
	R10-3ER	II	--	9	x	15	0.94	--	--	--	--	--	--	--	ON LIGHT POLE
3-12	S1-1	II	--	36	x	36	--	--	--	6.75	--	1	--	--	ON LIGHT POLE
	S16-7L	II	--	24	x	12	--	--	--	2.00	--	1	--	--	ON LIGHT POLE

3

3

TYPE II PERMANENT SIGNING

2230-07-73 W GREENFIELD AVENUE

SIGN NO.	SIGN CODE & SIZE	SIGN TYPE	SIGN MESSAGE	TYPE II SIGN SIZE			637.2210	637.2215	637.2220	637.2230	638.2102	638.2602	638.3000	SPV.0060.16	REMARKS / NEW SIGN LOCATION
				W [IN.]	x H [IN.]	H [SF]	SIGNS TYPE II REFLC H [SF]	SIGNS TYPE II REFLC SH [SF]	SIGNS TYPE II REFLC F [SF]	MOVING SIGNS TYPE II [EA]	REMOVING SIGNS TYPE II [EA]	REMOVING SMALL SIGN SUPPORTS [EA]	ROUND STEEL SIGN POST SYSTEM [EA]		
3-13	R7-2D (MOD)	II	SCHOOL DAYS 7:30 AM TO 4:00 PM	18	x 24		3.00	--	--	--	--	1	1	1	--
3-14	D1-1	--	S 53RD ST	--	x --	--	--	--	--	1	--	--	--	--	--
	D1-1	--	W GREENFIELD AVE	--	x --	--	--	--	--	1	--	--	--	--	--
	R1-1	--	--	--	x --	--	--	--	--	--	1	1	--	--	--
	R1-1	II	--	30	x 30	5.18	--	--	--	--	--	--	1	--	--
3-15	S4-51	II	20	24	x 48	--	--	6.63	1.38	--	2	1	--	--	--
3-16	R7 (SPECIAL)	--	--	--	x --	--	--	--	--	1	--	--	--	--	ON LIGHT POLE
3-17	R7-1	--	--	--	x --	--	--	--	--	--	1	1	--	--	--
3-18	S1-1	II	--	36	x 36	--	--	--	6.75	--	--	--	--	--	ON LIGHT POLE
	S16-7L	II	--	24	x 12	--	--	--	2.00	--	--	--	--	--	ON LIGHT POLE
3-19	S1-1	II	--	36	x 36	--	--	--	6.75	--	--	--	--	--	ON LIGHT POLE
	S16-7R	II	--	24	x 12	--	--	--	2.00	--	--	--	--	--	ON LIGHT POLE
	R10-3ER	II	--	9	x 15	0.94	--	--	--	--	--	--	--	--	ON LIGHT POLE
3-20	S4-51	--	--	--	x --	--	--	--	--	--	1	--	--	--	REMOVE FROM MAST ARM
	S1-1	--	--	--	x --	--	--	--	--	--	1	--	--	--	REMOVE FROM LIGHT POLE
	S16-7L	--	--	--	x --	--	--	--	--	--	1	--	--	--	REMOVE FROM LIGHT POLE
3-21	R5-2	II	--	24	x 24	4.00	--	--	--	--	--	--	1	--	--
3-22	D1-1	--	S 52ND ST	--	x --	--	--	--	--	1	--	--	--	--	--
	D1-1	--	W GREENFIELD AVE	--	x --	--	--	--	--	1	--	--	--	--	--
	R1-1	--	--	--	x --	--	--	--	--	--	1	1	--	--	--
	R1-1	II	--	30	x 30	5.18	--	--	--	--	--	--	1	--	--
3-23	S1-1	II	--	36	x 36	--	--	--	6.75	--	1	--	--	--	ON SIGNAL POLE
	S16-7L	II	--	24	x 12	--	--	--	2.00	--	1	--	--	--	ON SIGNAL POLE
	R10-3EL	II	--	9	x 15	0.94	--	--	--	--	--	--	--	--	ON SIGNAL POLE
3-24	S1-1	II	--	36	x 36	--	--	--	6.75	--	1	--	--	--	ON SIGNAL POLE
	S16-7R	II	--	24	x 12	--	--	--	2.00	--	1	--	--	--	ON SIGNAL POLE
3-25	R7 (SPECIAL)	--	--	--	x --	--	--	--	--	1	--	--	--	ON LIGHT POLE	
4-1	R7-6D(MOD)	II	SCHOOL BUS LOADING ZONE	18	x 24	3.00	--	--	--	--	1	--	1	--	--
	R7-2D (MOD)	II	SCHOOL DAYS 7:30 AM TO 4:00 PM	18	x 24	3.00	--	--	--	--	1	--	--	--	--
4-2	S1-1	II	--	36	x 36	--	--	--	6.75	--	--	--	--	--	ON SIGNAL POLE
	S16-7R	II	--	24	x 12	--	--	--	2.00	--	--	--	--	--	ON SIGNAL POLE
4-3	S1-1	II	--	36	x 36	--	--	--	6.75	--	--	--	--	--	ON SIGNAL POLE
	S16-7L	II	--	24	x 12	--	--	--	2.00	--	--	--	--	--	ON SIGNAL POLE
	R10-3EL	II	--	9	x 15	0.94	--	--	--	--	--	--	--	--	ON SIGNAL POLE

3

3

TYPE II PERMANENT SIGNING

2230-07-73 W GREENFIELD AVENUE

SIGN NO.	SIGN CODE & SIZE	SIGN TYPE	SIGN MESSAGE	TYPE II SIGN SIZE			637.2210	637.2215	637.2220	637.2230	638.2102	638.2602	638.3000	SPV.0060.16	REMARKS / NEW SIGN LOCATION
				W [IN.]	x	H [IN.]	SIGNS TYPE II REFLC H [SF]	SIGNS TYPE II REFLC H FOLDING [SF]	SIGNS TYPE II REFLC SH [SF]	SIGNS TYPE II REFLC F [SF]	MOVING SIGNS TYPE II [EA]	REMOVING SIGNS TYPE II [EA]	REMOVING SMALL SIGN SUPPORTS [EA]	ROUND STEEL SIGN POST SYSTEM [EA]	
4-4	S1-1	II	--	36	x	36	--	--	--	6.75	--	--	--	--	ON SIGNAL POLE
	S16-7R	II	--	24	x	12	--	--	--	2.00	--	--	--	--	ON SIGNAL POLE
4-5	S1-1	II	--	36	x	36	--	--	--	6.75	--	--	--	--	ON SIGNAL POLE
	S16-7L	II	--	24	x	12	--	--	--	2.00	--	--	--	--	ON SIGNAL POLE
	R10-3EL	II	--	9	x	15	0.94	--	--	--	--	--	--	--	ON SIGNAL POLE
4-6	S4-51	--	--	--	x	--	--	--	--	--	1	--	--	--	REMOVE FROM MAST ARM
	R7-6D(MOD)	II	SCHOOL BUS LOADING ZONE	18	x	24	3.00	--	--	--	1	--	1	1	--
4-7	R7 (SPECIAL)	--	SCHOOL DAYS 7:30 AM TO 4:00 PM	--	x	--	--	--	--	1	--	1	1	1	--
4-8	D1-1	--	S 50TH ST	--	x	--	--	--	--	1	--	--	--	--	--
	D1-1	--	W GREENFIELD AVE	--	x	--	--	--	--	1	--	--	--	--	--
	R1-1	--	--	--	x	--	--	--	--	--	1	1	--	--	--
	R1-1	II	--	30	x	30	5.18	--	--	--	--	--	1	1	--
4-9	R5-2	II	--	24	x	24	4.00	--	--	--	1	1	1	1	--
4-10	S4-51	II	20	24	x	48	--	--	6.63	1.38	--	2	--	1	--
4-11	R7 (SPECIAL)	--	--	--	x	--	--	--	--	1	1	1	--	--	--
	R7-1	--	--	--	x	--	--	--	--	--	1	1	--	--	--
	R7-1D	II	--	18	x	24	3.00	--	--	--	--	--	1	1	--
4-12	R7-1	--	--	--	x	--	--	--	--	--	1	1	--	--	--
4-13	S1-1	II	--	36	x	36	--	--	--	6.75	--	--	--	--	ON SIGNAL POLE
	S16-7L	II	--	24	x	12	--	--	--	2.00	--	--	--	--	ON SIGNAL POLE
4-14	S1-1	II	--	36	x	36	--	--	--	6.75	--	--	--	--	ON SIGNAL POLE
	S16-7R	II	--	24	x	12	--	--	--	2.00	--	--	--	--	ON SIGNAL POLE
	R10-3ER	II	--	9	x	15	0.94	--	--	--	--	--	--	--	ON SIGNAL POLE
4-15	R5-2	II	--	24	x	24	4.00	--	--	--	1	1	1	1	--
4-16	D1-1	--	S 51ST ST	--	x	--	--	--	--	1	--	--	--	--	--
	D1-1	--	W GREENFIELD AVE	--	x	--	--	--	--	1	--	--	--	--	--
	R1-1	--	--	--	x	--	--	--	--	--	1	1	--	--	--
	R1-1	II	--	30	x	30	5.18	--	--	--	--	--	1	1	--
4-17	S1-1	II	--	36	x	36	--	--	--	6.75	--	--	--	--	ON SIGNAL POLE
	S16-7L	II	--	24	x	12	--	--	--	2.00	--	--	--	--	ON SIGNAL POLE
	R10-3EL	II	--	9	x	15	0.94	--	--	--	--	--	--	--	ON SIGNAL POLE
4-18	S1-1	II	--	36	x	36	--	--	--	6.75	--	--	--	--	ON SIGNAL POLE
	S16-7R	II	--	24	x	12	--	--	--	2.00	--	--	--	--	ON SIGNAL POLE

3

3

TYPE II PERMANENT SIGNING

2230-07-73 W GREENFIELD AVENUE

SIGN NO.	SIGN CODE & SIZE	SIGN TYPE	SIGN MESSAGE	TYPE II SIGN SIZE			637.2210	637.2215	637.2220	637.2230	638.2102	638.2602	638.3000	SPV.0060.16	REMARKS / NEW SIGN LOCATION
				W [IN.]	x H [IN.]		SIGNS TYPE II REFLC H [SF]	SIGNS TYPE II REFLC H FOLDING [SF]	SIGNS TYPE II REFLC SH [SF]	SIGNS TYPE II REFLC F [SF]	MOVING SIGNS TYPE II [EA]	REMOVING SIGNS TYPE II [EA]	REMOVING SMALL SIGN SUPPORTS [EA]	ROUND STEEL SIGN POST SYSTEM [EA]	
4-19	R7 (SPECIAL)	--	--	--	x	--	--	--	--	1	--	--	--	ON LIGHT POLE	
4-20	S5-2	--	--	--	x	--	--	--	--	--	1	--	--	--	
4-21	DIRECTIONAL	--	WEST MILWAUKEE WELCOME	--	x	--	--	--	--	1	--	--	--	ON LIGHT POLE	
	R7-1L	II		18	x	24	3.00	--	--	--	--	--	--	ON LIGHT POLE	
4-22	R4-7	II	--	24	x	30	5.00	--	--	--	--	--	1	--	
5-1	S1-1	II	--	36	x	36	--	--	--	6.75	--	--	--	ON LIGHT POLE	
	S16-9P	II	--	24	x	12	--	--	--	2.00	--	--	--		
	R2-6P	II	--	24	x	18	3.00	--	--	--	--	--	--		
5-2	W12-1D	II	--	24	x	24	4.00	--	--	--	1	1	1	2' HEIGHT	
5-3	D1-1	--	S 49TH ST	--	x	--	--	--	--	1	--	--	--	--	
	D1-1	--	W GREENFIELD AVE	--	x	--	--	--	--	1	--	--	--	--	
	R1-1	II	--	30	x	30	5.18	--	--	--	2	1	1	--	
	R3-53R	II	--	24	x	30	5.00	--	--	--	--	--	--	--	
5-4	R5-2	II	--	24	x	24	4.00	--	--	--	1	1	1	--	
5-5	D1-1	--	W GREENFIELD AVE	--	x	--	--	--	--	1	--	--	--	ON LIGHT POLE	
	R1-1F	II	--	30	x	30	--	5.18	--	--	1	--	--	ON LIGHT POLE	
	R10-11B	II	--	24	x	24	4.00	--	--	--	1	--	--	ON LIGHT POLE	
	R3-2	II	--	24	x	24	4.00	--	--	--	--	--	--	ON LIGHT POLE	
5-6	R7-1	--	--	--	x	--	--	--	--	--	1	1	--	--	
5-7	R1-1F	II	--	30	x	30	--	5.18	--	--	2	1	1	ON SIGNAL POLE	
5-8	R3-2	II	--	24	x	24	4.00	--	--	--	--	--	--	ON MONOTUBE ARM	
5-9	R1-1	'	--	--	x	--	--	--	--	--	2	1	--	--	
5-10	R7-1	--	--	--	x	--	--	--	--	--	2	--	--	--	
5-11	R7 (SPECIAL)	--	--	--	x	--	--	--	--	--	1	--	--	--	
5-12	J3-1	II	--	24	x	57	9.50	--	--	--	--	1	--	1	
	M4-5	--	--				--	--	--	--	--	--	--	--	
	M1-1	--	--				--	--	--	--	--	--	--	--	
	M6-1	--	--				--	--	--	--	--	--	--	--	
5-13	R1-1F	II	--	30	x	30	--	5.18	--	--	1	--	--	ON SIGNAL POLE	
5-14	R5-2	II	--	24	x	24	4.00	--	--	--	--	--	--	ON LIGHT POLE	
	R12-1	II	--	24	x	30	5.00	--	--	--	--	--	--	ON LIGHT POLE	
5-15	R6-2R	II	--	24	x	30	5.00	--	--	--	--	--	1	--	

3

3

TYPE II PERMANENT SIGNING

2230-07-73 W GREENFIELD AVENUE

SIGN NO.	SIGN CODE & SIZE	SIGN TYPE	SIGN MESSAGE	TYPE II SIGN SIZE			637.2210	637.2215	637.2220	637.2230	638.2102	638.2602	638.3000	SPV.0060.16	REMARKS / NEW SIGN LOCATION
				W [IN.]	x H [IN.]	H [SF]	SIGNS TYPE II REFLC H [SF]	SIGNS TYPE II REFLC SH [SF]	SIGNS TYPE II REFLC F [SF]	MOVING SIGNS TYPE II [EA]	REMOVING SIGNS TYPE II [EA]	REMOVING SMALL SIGN SUPPORTS [EA]	ROUND STEEL SIGN POST SYSTEM [EA]		
5-16	R4-7	II	--	24	x 30	5.00	--	--	--	--	--	--	1	--	
5-17	R1-1	II	--	30	x 30	5.18	--	--	--	--	1	1	1	--	
5-18	J3-1	II	--	24	x 57	9.50	--	--	--	--	3	--	1	ON LIGHT POLE	
	M4-5	--	--			--	--	--	--	--	--	--	--	--	
	M1-1	--	--			--	--	--	--	--	--	--	--	--	
	M6-1	--	--			--	--	--	--	--	--	--	--	--	
	R7-1D	II	--	18	x 24	3.00	--	--	--	--	--	--	--	ON LIGHT POLE	
5-19	R5-2, R3-2, R5-2, R12-1	--	--	--	x --	--	--	--	--	--	4	1	--	2 SIGNS ON SIGNAL POLE & 2 SIGNS ON A POST	
5-20	W12-1D	--	--	--	x --	--	--	--	--	--	1	1	--	--	
5-21	D1-1	--	W BELOIT RD	--	x --	--	--	--	--	1	2	--	--	ON SIGNAL POLE	
5-22	R10-11S	II	--	24	x 36	--	--	--	--	--	1	--	--	ON SIGNAL POLE	
	R1-1F	II	--	30	x 30	--	5.18	--	--	--	1	--	--	ON SIGNAL POLE	
5-23	D1-1	--	W GREENFIELD AVE	--	x --	--	--	--	--	1	--	--	--	ON SIGNAL POLE	
5-24	R4-7	--	--	--	x --	--	--	--	--	--	2	--	--	ON SIGNAL POLE	
5-25	R1-1	--	--	--	x --	--	--	--	--	--	2	--	--	ON SIGNAL POLE	
5-26	R4-7	II	--	24	x 30	5.00	--	--	--	--	--	--	1	--	
5-27	W5-52L	--	--	--	x --	--	--	--	--	--	1	1	--	--	
5-28	S1-1	II	--	36	x 36	--	--	--	6.75	--	--	--	--	ON LIGHT POLE	
	S16-9P	II	--	24	x 12	--	--	--	2.00	--	--	--	--		
	R2-6P	II	--	24	x 18	3.00	--	--	--	--	--	--	--		
	R7-1D	II	--	18	x 24	3.00	--	--	--	--	--	--	--		
6-1	R7-1D	II	--	18	x 24	3.00	--	--	--	--	1	1	--	ON LIGHT POLE	
6-2	N/A	--	EMERGENCY EXIT DO NOT BLOCK	--	x --	--	--	--	--	1	1	--	1	--	
6-3	R7-1D	II	--	18	x 24	3.00	--	--	--	--	1	1	1	--	
6-4	S1-1	II	--	36	x 36	--	--	--	6.75	--	--	--	1	--	
	S16-7L	II	--	24	x 12	--	--	--	2.00	--	--	--	--	--	
6-5	S1-1	--	--	--	x --	--	--	--	--	--	2	1	--	--	
6-6	S4-51	II	20	24	x 48	--	--	6.63	1.38	--	--	--	1	--	
6-7	S4-51	--	--	--	x --	--	--	--	--	--	3	--	--	--	
6-8	R4-7	II	--	24	x 30	5.00	--	--	--	--	--	--	1	--	
6-9	R3-17	II	--	30	x 24	5.00	--	--	--	--	--	--	1	--	
	R3-17BP	II	--	30	x 12	2.50	--	--	--	--	--	--	--	--	
6-10	S1-1	II	--	36	x 36	--	--	--	6.75	--	1	--	1	--	
	S16-7L	II	--	24	x 12	--	--	--	2.00	--	1	--	--	--	

3

3

TYPE II PERMANENT SIGNING

2230-07-73 W GREENFIELD AVENUE

SIGN NO.	SIGN CODE & SIZE	SIGN TYPE	SIGN MESSAGE	TYPE II SIGN SIZE			637.2210	637.2215	637.2220	637.2230	638.2102	638.2602	638.3000	SPV.0060.16	REMARKS / NEW SIGN LOCATION
				W [IN.]	x H [IN.]	H [SF]	SIGNS TYPE II REFLC H [SF]	SIGNS TYPE II REFLC H FOLDING [SF]	SIGNS TYPE II REFLC SH [SF]	SIGNS TYPE II REFLC F [SF]	MOVING SIGNS TYPE II [EA]	REMOVING SIGNS TYPE II [EA]	REMOVING SMALL SIGN SUPPORTS [EA]	ROUND STEEL SIGN POST SYSTEM [EA]	
7-1	S1-1	II	--	36	x	36	--	--	--	6.75	--	--	--	1	--
	S16-7L	II	--	24	x	12	--	--	--	2.00	--	--	--	--	--
7-2	S4-51	--	--	--	x	--	--	--	--	--	3	--	--	--	--
	R3-1	II	--	24	x	24	4.00	--	--	--	--	--	--	--	ON LIGHT POLE
	R3-2	II	--	24	x	24	4.00	--	--	--	--	--	--	--	ON LIGHT POLE
7-3	S4-51	II	20	24	x	48	--	--	6.63	1.38	--	2	--	--	ON LIGHT POLE
7-4	S1-1	II	--	36	x	36	--	--	--	6.75	--	1	1	1	--
	S16-7L	II	--	24	x	12	--	--	--	2.00	--	1	--	--	--
7-5	R2-1	--	--	--	x	--	--	--	--	--	1	--	--	--	--
8-1	S1-1	II	--	36	x	36	--	--	--	6.75	--	--	--	1	--
	S16-9P	II	--	24	x	12	--	--	--	2.00	--	--	--	--	--
	R2-6P	II	--	24	x	18	3.00	--	--	--	--	--	--	--	--
	R7-1D	--	--	--	x	--	--	--	--	1	--	1	--	--	--
8-2	R2-1	II	30	24	x	30	5.00	--	--	--	--	--	--	1	--
	S5-2	II	--	24	x	30	5.00	--	--	--	--	--	--	--	--
TOTALS							277.660	20.720	26.500	215.500	43	106	46	53	

3

3

FIELD OFFICE TYPE D

PROJECT	642.5201 EACH
ID 2230-70-73	1
TOTALS	1

TRAFFIC CONTROL

STAGE	DURATION DAYS	643.0300 TRAFFIC CONTROL DRUMS		643.0420 TRAFFIC CONTROL BARRICADES TYPE III		643.0705 TRAFFIC CONTROL WARNING LIGHTS TYPE A		643.0715 TRAFFIC CONTROL WARNING LIGHTS TYPE C		643.0900 TRAFFIC CONTROL SIGNS		643.1050 TRAFFIC CONTROL SIGNS PCMS	
		EACH	DAY	EACH	DAY	EACH	DAY	EACH	DAY	EACH	DAY	EACH	DAY
W GREENFIELD AVE													
STAGE 1	91	107	9,737	76	6,916	152	13,832	11	1,001	263	21,807	3	21
STAGE 2	89	116	10,324	93	8,277	186	16,554	10	890	272	22,635	2	14
TOTALS	180		20,061		15,193		30,386		1,891		44,442		35

TRAFFIC CONTROL

STAGE	643.0920 TRAFFIC CONTROL COVERING SIGNS TYPE II			643.3760 TEMPORARY MARKING RAISED	643.5000 TRAFFIC CONTROL
	EACH	CYCLES	SIGNS	EACH	EACH
W GREENFIELD AVE					
STAGE 1	1	1	1	6	
STAGE 2	1	1	1	8	1
TOTALS			2	14	1

TEMPORARY MARKING LINE

STAGE	643.3105 PAINT 4-INCH (YELLOW)	643.3150 REMOVABLE TAPE 4-INCH
	LF	LF
GREENFIELD AVE.		
STAGE 1	2,607	101
STAGE 2	-	3,185
TOTALS	2,607	3,286

TEMPORARY MARKING OTHER

STAGE	643.3805 MARKING STOP LINE PAINT 18-INCH	643.3850 MARKING STOP LINE REMOVABLE TAPE 18-INCH
	LF	LF
GREENFIELD AVE.		
STAGE 1	44	11
STAGE 2	-	77
TOTALS	44	88

TEMPORARY PEDESTRIAN FACILITIES

STAGE	644.1410 SURFACE ASPHALT	644.1430 SURFACE PLATE	644.1601 CURB RAMP	644.1605 DETECTABLE WARNING FIELD	644.1810 BARRICADE
	SF	SF	DAY	SF	LF
W GREENFIELD AVE					
STAGE 1	185	-	30	110	2,898
STAGE 2	-	135	90	120	1,758
TOTALS	185	135	120	230	4,656

MARKING REMOVAL

STATION TO STATION	646.9010 LINE WATER BLASTING 4-INCH	646.9110 LINE WATER BLASTING 8-INCH	646.9210 LINE WATER BLASTING WIDE	646.9310 SPECIAL MARKING WATER BLASTING
	LF	LF	LF	EACH
W GREENFIELD AVE				
22+15 - 22+85	140	-	-	-
49+50 - 56+75	1,434	656	20	1
TOTALS	1,574	656	20	1

3

3

<u>MARKING LINE</u>			
	646.1020 EPOXY 4-INCH (WHITE)	646.1020 EPOXY 4-INCH (YELLOW)	646.3020 EPOXY 8-INCH (WHITE)
STATION TO STATION	LF	LF	LF
<u>W GREENFIELD AVE</u>			
23+00 - 32+00	3,093	1,628	-
32+00 - 42+00	3,192	1,730	-
42+00 - 57+00	1,972	2,156	580
TOTALS	8,257	5,514	580
		13,771	

<u>MARKING OTHER</u>								
	646.5020 ARROW EPOXY	646.5120 WORD EPOXY	646.5220 SYMBOL EPOXY	646.6120 STOP LINE EPOXY 18-INCH	646.7020 DIAGONAL EPOXY 6-INCH	646.7120 DIAGONAL EPOXY 12-INCH	646.7420 CROSSWALK EPOXY TRAVERSE LINE 6-INCH	646.7520 CROSSWALK EPOXY BLOCK STYLE 24-INCH
STATION TO STATION	EACH	EACH	EACH	LF	LF	LF	LF	LF
<u>W GREENFIELD AVE</u>								
23+00 - 32+00	6	-	6	39	-	16	526	-
32+00 - 42+00	7	-	7	78	-	20	391	300
42+00 - 57+00	15	2	5	170	110	148	659	205
TOTALS	28	2	18	287	110	184	1,576	505

<u>CONSTRUCTION STAKING</u>			
ITEM	DESCRIPTION	QUANTITY	UNIT
650.4500	CONSTRUCTION STAKING SUBGRADE	2,906	LF
650.5500	CONSTRUCTION STAKING CURB GUTTER AND CURB & GUTTER	7,471	LF
650.7000	CONSTRUCTION STAKING CONCRETE PAVEMENT	2,906	LF
650.8501	CONSTRUCTION STAKING ELECTRICAL INSTALLATIONS (ID 2230-07-73)	1	EACH
650.9000	CONSTRUCTION STAKING CURB RAMPS	56	EACH
650.9500	CONSTRUCTION STAKING SIDEWALK (ID 2230-07-73)	1	EACH
650.9911	CONSTRUCTION STAKING SUPPLEMENTAL CONTROL (ID 2230-07-73)	1	EACH
650.9920	CONSTRUCTION STAKING SLOPE STAKES	2,906	LF

<u>SAWING</u>		
	690.0150 ASPHALT	690.0250 CONCRETE
STATION TO STATION	LF	LF
<u>W GREENFIELD AVE - EB (STAGE 2)</u>		
23+00 - 32+00	104	254
32+00 - 42+00	26	255
42+00 - 50+00	91	132
<u>W GREENFIELD AVE - WB (STAGE 1)</u>		
23+00 - 32+00	46	1,075
32+00 - 42+00	53	1,268
42+00 - 50+00	134	1,167
TOTALS	454	4,151

999.1501.S CRACK AND DAMAGE SURVEY	
PROJECT	EACH
ID 2230-70-73	3
TOTALS	3

TEMPORARY PIPE CONNECTION

SPV.0060.15
12-INCH

STATION TO STATION	EACH
W. GREENFIELD AVE	
30+44 RT	1
TOTALS	1

UTILITY LINE OPENING

SPV.0060.17
UTILITY LINE OPENING

STATION	EACH
W GREENFIELD AVE	
UNDISTRIBUTED	16
TOTALS	16

SECTION CORNER MONUMENTS

SPV.0060.18
SECTION CORNER
MONUMENTS

STATION	EACH
W GREENFIELD AVE	
36+75	1
37+12	1
TOTALS	2

SANITARY MANHOLES

STATION	CAT 20	CAT 20
	SPV.0060.19 ADJUST SANITARY SEWER MANHOLE	SPV.0060.20 INTERNAL SANITARY MANHOLE SEAL
	EACH	EACH
<u>W GREENFIELD AVE</u>		
25+05 RT	1	1
26+35 LT	1	1
29+44 LT	1	1
32+42 RT	1	1
35+37 RT	1	1
38+05 LT	1	1
40+78 RT	1	1
43+13 RT	1	1
44+55 LT	1	1
44+72 LT	1	1
47+07 RT	1	1
TOTALS	11	11

ADJUSTING WATER VALVES

STATION	CAT 20
	SPV.0060.21 ADJUSTING WATER VALVES
	EACH
<u>W GREENFIELD AVE</u>	
23+28, 32' LT	1
25+06, 25' RT	1
25+43, 25' RT	1
25+85, 25' RT	1
26+05, 5' LT	1
26+42, 34' RT	1
26+61, 5' LT	1
26+64, 8' LT	1
27+15, 24' LT	1
27+15, 25' RT	1
27+45, 24' LT	1
27+83, 25' RT	1
28+13, 26' RT	1
28+54, 25' LT	1
28+92, 27' RT	1
29+50, 33' RT	1
29+50, 34' LT	1
29+71, 6' LT	1
29+74, 8' LT	1
30+24, 25' RT	1
30+27, 26' LT	1
31+08, 25' RT	1
31+48, 25' RT	1
31+52, 24' LT	1
32+48, 33' LT	1
32+49, 35' RT	1
32+73, 10' LT	1
32+86, 25' LT	1
33+29, 26' LT	1
33+29, 25' RT	1
33+67, 26' RT	1
34+05, 26' RT	1
34+06, 24' LT	1
34+47, 24' RT	1
34+49, 24' LT	1
34+86, 24' LT	1

ADJUSTING WATER VALVES

STATION	CAT 20
	SPV.0060.21 ADJUSTING WATER VALVES
	EACH
<u>W GREENFIELD AVE</u>	
34+88, 26' RT	1
35+08, 8' LT	1
35+33, 34' LT	1
35+44, 33' RT	1
35+67, 7' LT	1
35+70, 10' LT	1
35+94, 25' RT	1
36+62, 25' RT	1
37+20, 24' RT	1
37+50, 9' LT	1
37+53, 24' RT	1
38+11, 31' RT	1
38+35, 9' LT	1
38+65, 25' RT	1
38+98, 25' RT	1
39+45, 25' RT	1
39+83, 25' RT	1
40+44, 24' RT	1
40+47, 5' LT	1
40+86, 33' LT	1
40+88, 35' LT	1
40+90, 25' RT	1
41+08, 6' LT	1
41+50, 27' RT	1
42+04, 25' LT	1
42+59, 24' LT	1
43+64, 34' RT	1
43+99, 21' LT	1
44+28, 18' LT	1
503+95, 23' LT	1
44+40, 31' LT	1
44+43, 44' LT	1
507+20, 22' LT	1
44+84, 5' LT	1
47+36, 7' LT	1
49+08, 6' LT	1
TOTALS	72

STONE VENEER SEAT WALL PLANTER

STATION TO STATION	CAT 20	CAT 20	CAT 20
	SPV.0035.01 BACKFILL FOR PLANT BEDS, 24- INCH	SPV.0060.22 STONE VENEER SEAT WALL PLANTER STA. 48+15	SPV.0060.23 STONE VENEER SEAT WALL PLANTER STA. 48+81
	CY	EACH	EACH
<u>W GREENFIELD AVE</u>			
STA. 48+15	20	1	-
STA. 48+81	5	-	1
TOTALS	25	1	1

3

LIGHTING REMOVAL

STATION	OFFSET	204.0195*	204.9060.S.05	653.0905*	SPV 0060.10
		REMOVING CONCRETE BASES	REMOVING LIGHTING UNITS	REMOVING PULL BOXES	TEMPORARY LIGHTING SYSTEM
		EACH	EACH	EACH	EACH
23+34.0	RT			1	
23+51.2	LT	1	1		
23+54.8	LT			1	
24+34.7	RT	1	1		
25+12.0	LT	1	1		
26+00.0	RT	1	1		
26+13.7	LT			1	
26+72.0	LT	1	1		
27+55.0	RT	1	1		
28+34.2	LT	1	1		
29+10.4	RT	1	1		
29+27.2	LT			1	
29+61.9	LT			1	
29+81.2	LT	1	1		
30+56.1	RT	1	1		
31+30.0	LT	1	1		
32+05.7	RT	1	1		
32+25.0	LT			1	
32+58.5	LT			1	
32+77.1	LT	1	1		
33+52.5	RT	1	1		
34+26.4	LT	1	1		
35+01.0	RT	1	1		
35+08.8	RT			1	
35+17.8	LT			1	
35+22.2	LT	1	1		
35+55.0	LT			1	
35+73.2	LT	1	1		
36+68.8	RT	1	1		
37+55.8	LT	1	1		
37+74.6	LT			1	
38+40.5	RT	1	1		
39+30.7	LT	1	1		
40+24.0	RT	1	1		
40+59.7	LT	1	1		

LIGHTING REMOVAL

STATION	OFFSET	204.0195*	204.9060.S.05	653.0905*	SPV 0060.10
		REMOVING CONCRETE BASES	REMOVING LIGHTING UNITS	REMOVING PULL BOXES	TEMPORARY LIGHTING SYSTEM
		EACH	EACH	EACH	EACH
40+60.7	LT			1	
40+94.5	LT			1	
41+10.2	LT	1	1		
42+31.5	RT	1	1		
43+06.3	RT	1	1		
43+52.9	RT			1	
43+57.1	RT	1	1		
43+73.5	LT			1	
43+98.1	RT			1	
44+10.1	LT			1	
44+17.2	RT			1	
44+19.7	RT			1	
44+62.2	RT			1	
44+90.7	RT			1	
45+12.9	LT			1	
46+25.4	LT	1	1		
47+54.4	RT	1	1		
48+89.8	LT	1	1		
PROJECT					1
TOTALS		31	31	22	1

*ADDITIONAL QUANTITIES SHOWN ELSEWHERE

3

PULL BOXES

653.0135
STEEL 24X36

DESCRIPTION	STATION	OFFSET	EACH
PB-1	29+27.0	37.5' LT	1
PB-2	29+62.0	37.5' LT	1
PB-3	32+24.0	35.5' LT	1
PB-4	32+59.0	35.5' LT	1
PB-5	35+20.5	38.0' LT	1
PB-6	35+56.0	38.0' LT	1
PB-7	35+02.0	24.0' RT	1
PB-8	35+74.0	25.0' LT	1
PB-9	37+70.0	24.5' RT	1
PB-10	38+18.0	23.0' LT	1
PB-11	40+59.5	44.6' LT	1
PB-12	40+95.0	44.6' LT	1
PB-13	42+20.0	32.0' LT	1
PB-14	42+20.0	32.0' RT	1
PB-15	504+55.0	22.5' LT	1
PB-16	504+55.0	26.5' RT	1
PB-17	43+75.0	44.7' LT	1
PB-18	44+09.0	45.1' LT	1
PB-19	44+68.0	61.3' LT	1
PB-20	45+31.0	60.7' LT	1
PB-21	45+60.0	35.5' LT	1
PB-22	45+60.0	37.0' RT	1

22

LIGHTING CONTROL CABINETS

654.0230 656.0201.02 659.2230
CONCRETE CONTROL ELECTRICAL SERVICE L30 LIGHTING
CABINET BASES TYPE METER BREAKER CONTROL CABINET
L30 PEDESTAL 240/480 30-INCH

STREET	STATION	OFFSET	EACH	EACH	EACH
W GREENFIELD AVE & W BELOIT I	45+49.0	43.0' LT	1	1	1
TOTALS			1	1	1

**LIGHTING QUANTITIES
ALL ITEMS CATEGORY 0010**

STREET LIGHTING WIRING AND CONDUIT

		652.0225*	655.0625	655.0625
		CONDUIT RIGID NON-METALLIC SCHEDULE 40 2-INCH	ELECTRICAL WIRE LIGHTING 6 AWG (UNDERGROUND PHASE AND NEUTRAL WIRES)	ELECTRICAL WIRE LIGHTING 6 AWG (UNDERGROUND GROUND WIRES)
FROM	TO	LF	LF	LF
B-1 (1,3) w/Camera	B-3 (1,3)	309	1252	313
B-3 (1,3)	B-5 (1,3)	275	1116	279
B-5 (1,3)	B-7 (1,3)	198	808	202
B-7 (1,3)	B-9 (1,3)	185	756	189
B-9 (1,3)	B-12 (1,3)	310	1256	314
B-12 (1,3)	PB-8	18	88	22
B-12 (1,3)	RFB SB1	68	144	72
B-12 (1,3)	RFB SB2	63	-	-
PB-8	PB-10	256	1040	260
PB-10	B-15 (1,3)	25	116	29
PB-10	RFB SB3	55	118	59
B-15 (1,3)	B-18 (1,3)	402	1624	406
B-18 (1,3)	PB-13	19	92	23
PB-13	PB-17	178	1092	182
PB-17	PB-18	45	294	49
PB-18	PB-19	86	540	90
PB-19	PB-20	73	462	77
PB-20	LCC-B	54	348	58
LCC-B	PB-21	35	156	39
PB-21	B-21 (5,7)	144	296	148
B-21 (5,7)	B-22 (5,7)	112	232	116
B-22 (5,7)	B-23 (5,7)	125	258	129
B-23 (5,7)	END CAP	46	0	50
B-2 (2,4)	B-4 (2,4)	294	596	298
B-4 (2,4)	B-6 (2,4)	208	424	212
B-6 (2,4)	B-8 (2,4)	253	514	257
B-8 (2,4)	B-10 (2,4)	192	392	196
B-10 (2,4)	PB-7	124	256	128
PB-7	B-11 (2,4)	22	52	26
B-11 (2,4)	RFB SB2	74	156	78
PB-7	B-13 (2,4)	116	480	120
B-13 (2,4)	PB-9	92	384	96
PB-9	B-14 (2,4)	20	96	24
B-14 (2,4)	RFB SB4	74	156	78
B-14 (2,4)	RFB SB3	65	-	-

STREET LIGHTING WIRING AND CONDUIT

		652.0225*	655.0625	655.0625
		CONDUIT RIGID NON-METALLIC SCHEDULE 40 2-INCH	ELECTRICAL WIRE LIGHTING 6 AWG (UNDERGROUND PHASE AND NEUTRAL WIRES)	ELECTRICAL WIRE LIGHTING 6 AWG (UNDERGROUND GROUND WIRES)
FROM	TO	LF	LF	LF
PB-9	B-16 (2,4)	187	764	191
B-16 (2,4)	B-17 (2,4)	134	552	138
B-17 (2,4)	PB-14	174	712	178
PB-14	PB-13	78	328	82
PB-15	END CAP	89	0	0
PB-15	PB-16	63	134	67
PB-16	END CAP	93	0	0
PB-16	B-19 (6,8)	44	96	48
B-19 (6,8)	PB-22	235	478	239
PB-22	B-20 (6,8)	75	158	79
B-20 (6,8)	END CAP	315	0	0
PB-22	PB-11	83	174	87
EX. POLE 56TH ST	PB-1	639	1286	643
PB-1	EX. POLE 54TH ST	30	68	34
PB-1	PB-2	60	128	64
PB-2	EX. POLE 54TH ST	30	252	126
PB-2	PB-3	275	558	279
PB-3	PB-4	57	122	61
PB-3	EX. POLE 53RD ST	22	96	48
PB-4	EX. LLC 53C	10	204	102
PB-4	PB-5	292	592	296
PB-5	EX. POLE 52ND ST	40	88	44
PB-5	PB-6	58	124	62
PB-6	EX. POLE 52ND ST	25	302	151
PB-6	PB-11	517	1042	521
PB-11	EX. POLE 50TH ST	24	56	28
PB-11	PB-12	45	98	49
PB-12	EX. POLE 50TH ST	129	266	133
PB-12	PB-13	150	308	154
PB-13	PB-17	178	364	182
PB-17	EX. POLE 49TH ST	29	66	33
PB-17	PB-18	49	106	53
PB18	EX. POLE 49TH ST	25	346	173
TOTAL		8,869	25,462	8,964

34,426

*ADDITIONAL QUANTITIES SHOWN ELSEWHERE

PROJECT NO: 2230-07-73

HWY: W. GREENFIELD AVENUE

COUNTY: MILWAUKEE

MISCELLANEOUS QUANTITIES

SHEET:

E

FILE NAME :

PLOT DATE :

PLOT BY :

PLOT NAME :

PLOT SCALE : 1:1

3

3

POLE WIRING

655.0610*
ELECTRICAL WIRE
LIGHTING 12 AWG
(POLE PHASE AND NEUTRAL
WIRES)

655.0610*
ELECTRICAL WIRE
LIGHTING 12 AWG
(POLE GROUND WIRES)

DESCRIPTION	LF	LF
B-1	76	43
B-2	76	43
B-3	76	43
B-4	76	43
B-5	76	43
B-6	76	43
B-7	76	43
B-8	76	43
B-9	76	43
B-10	76	43
B-11	76	43
B-12	76	43
B-13	76	43
B-14	76	43
B-15	76	43
B-16	76	43
B-17	76	43
B-18	76	43
B-19	76	43
B-20	76	43
B-21	76	43
B-22	92	51
SPARE	92	51
Camera on B-1	62	36
RRFB - STA.35+68.0 RT	32	21
RRFB - STA.35+09.0 LT	32	21
RRFB - STA.37+75.0 LT	32	21
RRFB - STA.38+34.0 RT	32	21
	0	0
SUBTOTAL	1,970	1,125
TOTAL		3,095

*ADDITIONAL QUANTITIES SHOWN ELSEWHERE

TRAFFIC CAMERA/RAPID FLASHING BEACON POWER TRANSFORMER

SPV 0060.09
240/120V
TRANSFORMER

FEEDS	STATION	OFFSET	EACH
CAMERA	23+60.0	32.0' LT	1
RAPID FLASHING BEACON	35+09.0	25.5' RT	1
RAPID FLASHING BEACON	35+68.0	27.0' LT	1
RAPID FLASHING BEACON	37+75.5	32.0' RT	1
RAPID FLASHING BEACON	38+27.0	25.0' LT	1
			5

LUMINAIRE AND POLE MOUNTINGS

DESCRIPTION	STATION	OFFSET	654.0105	SPV.0060.11	SPV.0060.12 *	SPV.0060.13	SPV.0060.14
			CONCRETE BASE TYPE 5	LIGHT POLE SPECIAL	LUMINAIRE SPECIAL	LUMINAIRE ARM 8-FOOT, SPECIAL	TRANSFORMER BASES BREAKAWAY 11 ¹ / ₂ INCH BOLT CIRCLE, SPECIAL
			EACH	EACH	EACH	EACH	EACH
B-1	23+60.0	32.0' LT	1	1	1	1	1
B-2	25+00.0	32.0' RT	1	1	1	1	-
B-3	26+55.0	32.0' LT	1	1	1	1	-
B-4	27+80.0	32.0' RT	1	1	1	1	-
B-5	29+16.0	32.0' LT	1	1	1	1	-
B-6	29+73.0	32.5' RT	1	1	1	1	-
B-7	31+00.0	32.0' LT	1	1	1	1	-
B-8	32+12.0	32.5' RT	1	1	1	1	-
B-9	32+70.5	32.0' LT	1	1	1	1	-
B-10	33+90.0	32.0' RT	1	1	1	1	-
B-11	35+09.0	25.5' RT	1	1	1	1	1
B-12	35+68.0	27.0' LT	1	1	1	1	1
B-13	36+92.0	32.0' RT	1	1	1	1	-
B-14	37+75.5	32.0' RT	1	1	1	1	1
B-15	38+27.0	25.0" LT	1	1	1	1	1
B-16	39+40.0	32.0' RT	1	1	1	1	-
B-17	40+60.0	32.0' RT	1	1	1	1	-
B-18	42+15.0	32.0' LT	1	1	1	1	-
B-19	504+75.0	27.0' RT	1	1	1	1	-
B-20	46+25.0	37.0' RT	1	1	1	1	-
B-21	46+90.0	35.0' LT	1	1	1	1	-
B-22	47+83.5	31.2' LT	1	1	2	2	-
B-23	48+94.0	31.0' LT	1	1	2	2	-
SPARE		31.0' LT	-	4	4	4	-
TOTALS			23	27	29	29	5

*ADDITIONAL QUANTITIES SHOWN ELSEWHERE

INTERSECTION OF
W GREENFIELD AVE & W BELOIT RD
ALL ITEMS CATEGORY 0010

3

3

REMOVING TRAFFIC SIGNALS

204.9060.S.04
REMOVING
TRAFFIC SIGNALS

LOCATION	EACH
W GREENFIELD AVE & W BELOIT RD	1
TOTALS	1

REMOVING CONCRETE BASES

204.0195*

REMOVING
CONCRETE BASES

EXISTING BASE NO.	EACH
CB1	1
SB1	1
SB2	1
SB3	1
SB4	1
SB5	1
SB6	1
SB7	1
SB8	1
SB9	1
TOTALS	10

*ADDITIONAL QUANTITIES SHOWN ELSEWHERE

CONCRETE BASES

654.0101* CONCRETE BASES TYPE 1
654.0102 CONCRETE BASES TYPE 2
654.0110 CONCRETE BASES TYPE 10
654.0120 CONCRETE BASES TYPE 10-SPECIAL
654.0217 CONCRETE CONTROL CABINET BASES TYPE 9 SPECIAL

BASE NO.	STATION	LOCATION	EACH	EACH	EACH	EACH	EACH
CB1	45+47.0	48.9' LT	-	-	-	-	1
SB1	45+39.9	35.0' LT	-	1	-	-	-
SB2	44+73.9	36.2' RT	-	-	-	1	-
SB3	44+23.4	41.8' RT	1	-	-	-	-
SB4	43+55.2	35.1' RT	-	-	1	-	-
SB5	43+52.4	27.5' RT	1	-	-	-	-
SB6	43+65.3	35.8' LT	-	-	-	1	-
SB7	44+21.9	33.0' LT	1	-	-	-	-
SB8	44+53.2	49.1' LT	-	1	-	-	-
SB9	45+33.0	52.0' LT	-	-	1	-	-
TOTALS			3	2	2	2	1

*ADDITIONAL QUANTITIES SHOWN ELSEWHERE

CONDUIT

652.0225* CONDUIT RIGID NONMETALLIC SCHEDULE 40 2-INCH
652.0235 CONDUIT RIGID NONMETALLIC SCHEDULE 40 3-INCH

FROM	TO	LF	LF
CB1	PB1	-	69
PB1	PB2	-	182
PB2	PB3	-	146
PB3	PB4	-	134
PB4	PB5	-	22
PB5	PB6	-	116
PB6	PB7	-	138
PB7	PB8	-	92
PB8	PB9	-	152
PB9	CB1	-	63
PB1	SB1	9	-
PB2	SB2	-	9
PB3	SB3	20	-
PB4	SB4	-	4
PB5	SB5	4	-
PB6	SB6	-	20
PB7	SB7	5	-
PB8	SB8	6	-
PB9	SB9	-	5
TOTALS		44	1,152

*ADDITIONAL QUANTITIES SHOWN ELSEWHERE

REMOVING PULL BOXES

653.0905*
REMOVING
PULL BOXES

PULL BOX NO.	EACH
PB1	1
PB2	1
PB3	1
PB4	1
PB5	1
PB6	1
TOTALS	6

*ADDITIONAL QUANTITIES SHOWN ELSEWHERE

PULL BOXES

653.0140

PULL BOXES
STEEL
24X42-
INCH

PULL BOX NO.	STATION	LOCATION	EACH
PB1	45+46.7	29.9' LT	1
PB2	44+81.6	33.3' RT	1
PB3	44+15.3	59.6' RT	1
PB4	43+52.4	37.5' RT	1
PB5	43+48.6	27.3' RT	1
PB6	43+48.6	30.8' LT	1
PB7	44+17.6	30.9' LT	1
PB8	44+53.9	55.2' LT	1
PB9	45+29.2	54.4' LT	1
TOTALS			9

INTERSECTION OF
W GREENFIELD AVE & W BELOIT RD
ALL ITEMS CATEGORY 0010

TRAFFIC SIGNAL CABLE

		655.0230*	655.0240	655.0260	655.0270
		CABLE TRAFFIC SIGNAL 5-14 AWG	CABLE TRAFFIC SIGNAL 7-14 AWG	CABLE TRAFFIC SIGNAL 12-14 AWG	CABLE TRAFFIC SIGNAL 15-14 AWG
FROM	TO	LF	LF	LF	LF
CB1	SB1	-	-	59	-
SB1	HEAD 4	21	-	-	-
SB1	HEAD 6	21	-	-	-
SB1	HEAD 22	15	-	-	-
CB1	SB2	-	-	-	166
SB2	HEAD 2	47	-	-	-
SB2	HEAD 3	21	-	-	-
SB2	HEAD 5	58	-	-	-
SB2	HEAD 23	15	-	-	-
CB1	SB3	-	-	-	266
SB3	HEAD 11	-	22	-	-
SB3	HEAD 16	21	-	-	-
SB3	HEAD 24	15	-	-	-
CB1	SB4	-	-	333	-
SB4	HEAD 17	40	-	-	-
SB4	HEAD 25	15	-	-	-
CB1	SB5	-	-	-	365
SB5	HEAD 1	21	-	-	-
SB5	HEAD 9	-	22	-	-
SB5	HEAD 18	15	-	-	-
CB1	SB6	-	-	-	307
SB6	HEAD 7	47	-	-	-
SB6	HEAD 10	-	59	-	-
CB1	SB7	-	-	207	-
SB7	HEAD 8	19	-	-	-
SB7	HEAD 19	15	-	-	-
CB1	SB8	-	-	146	-
SB8	HEAD 13	21	-	-	-
SB8	HEAD 15	21	-	-	-
SB8	HEAD 20	15	-	-	-
CB1	SB9	-	-	-	53
SB9	HEAD 12	-	22	-	-
SB9	HEAD 14	51	-	-	-
SB9	HEAD 21	15	-	-	-
TOTALS		529	125	745	1,157

*ADDITIONAL QUANTITIES SHOWN ELSEWHERE

ELECTRICAL WIRE TRAFFIC SIGNALS

			655.0515
			ELECTRICAL WIRE TRAFFIC SIGNALS 10 AWG
FROM	TO	LF	
CB1	SB1	59	
SB1	SB2	149	
SB2	SB3	142	
SB3	SB4	131	
SB4	SB5	59	
SB5	SB6	122	
SB6	SB7	134	
SB7	SB8	97	
SB8	SB9	127	
SB9	CB1	53	
TOTALS			1,335
PB1	SB1	29	
PB2	SB2	29	
PB3	SB3	40	
PB4	SB4	24	
PB5	SB5	24	
PB6	SB6	40	
PB7	SB7	25	
PB8	SB8	26	
PB9	SB9	25	

ELECTRICAL WIRE LIGHTING

		655.0320	655.0610*
		CABLE TYPE UF 2-10 AWG GROUNDED	ELECTRICAL WIRE LIGHTING 12 AWG
FROM	TO	LF	LF
CB1	SB1	59	-
SB1	LUMIN	-	117
SB1	SB2	149	-
SB2	LUMIN	-	123
SB2	SB4	209	-
SB4	LUMIN	-	123
CB1	SB9	53	-
SB9	LUMIN	-	123
SB9	SB8	127	-
SB8	LUMIN	-	117
SB8	SB6	197	-
SB6	LUMIN	-	123
TOTALS		794	726

*ADDITIONAL QUANTITIES SHOWN ELSEWHERE

TRAFFIC SIGNAL EVP DETECTOR CABLE

			655.0900
			TRAFFIC SIGNAL EVP DETECTOR CABLE
FROM	TO	LF	
CB1	SB2 (HEAD A)	202	
CB1	SB6 (HEAD B)	343	
CB1	SB9 (HEAD C)	89	
CB1	SB4 (HEAD D)	182	
TOTALS			816

ELECTRICAL SERVICE METER BREAKER PEDESTAL

		656.0201.01
		ELECTRICAL SERVICE METER BREAKER PEDESTAL
BASE NO.	EACH	
CB1	1	
TOTALS		1

* FINAL LOCATION TO BE DETERMINED BY THE ENGINEER IN THE FIELD

INTERSECTION OF
W GREENFIELD AVE & W BELOIT RD
ALL ITEMS CATEGORY 0010

POLES AND ARMS

	657.0100*	657.0255	657.0310	657.0350	657.0352	657.0420	657.0425*	657.0520	657.0530	657.0536	657.0614	657.0812	SPV.0060.12*
	PEDESTAL BASES	TRANSFORMER BASES BREAKAWAY 11 1/2- INCH BOLT CIRCLE	POLES TYPE 3	POLES TYPE 10	POLES TYPE 10-SPECIAL	TRAFFIC SIGNAL STANDARDS ALUMINUM 13-FOOT	TRAFFIC SIGNAL STANDARDS ALUMINUM 15-FOOT	MONOTUBE ARMS 20-FT	MONOTUBE ARMS 30-FT	MONOTUBE ARMS 35-FT- SPECIAL	LUMINAIRE ARMS SINGLE MEMBER 4-INCH CLAMP 8-FOOT	LUMINAIRE ARMS STEEL 12-FT	LUMINAIRE SPECIAL
SIGNAL BASE NO.	EACH	EACH	EACH	EACH	EACH	EACH	EACH	EACH	EACH	EACH	EACH	EACH	EACH
SB1	-	1	1	-	-	-	-	-	-	-	1	-	1
SB2	-	-	-	-	1	-	-	-	-	1	-	1	1
SB3	1	-	-	-	-	-	1	-	-	-	-	-	-
SB4	-	-	-	1	-	-	-	1	-	-	-	1	1
SB5	1	-	-	-	-	-	1	-	-	-	-	-	-
SB6	-	-	-	-	1	-	-	-	-	1	-	1	1
SB7	1	-	-	-	-	1	-	-	-	-	-	-	-
SB8	-	1	1	-	-	-	-	-	-	-	1	-	1
SB9	-	-	-	1	-	-	-	-	1	-	-	1	1
TOTALS	3	2	2	2	2	1	2	1	1	2	2	4	6

*ADDITIONAL QUANTITIES SHOWN ELSEWHERE

TRAFFIC SIGNAL FACES

		658.0173	658.0174	658.0416
		TRAFFIC SIGNAL FACE 3S 12- INCH	TRAFFIC SIGNAL FACE 4S 12- INCH	PEDESTRIAN SIGNAL FACE 16- INCH
SIGNAL HEAD NO.	SIGNAL BASE NO.	EACH	EACH	EACH
1	SB5	1	-	-
2	SB2	1	-	-
3	SB2	1	-	-
4	SB1	1	-	-
5	SB2	1	-	-
6	SB1	1	-	-
7	SB6	1	-	-
8	SB7	1	-	-
9	SB5	-	1	-
10	SB6	-	1	-
11	SB3	-	1	-
12	SB9	-	1	-
13	SB8	1	-	-
14	SB9	1	-	-
15	SB8	1	-	-
16	SB3	1	-	-
17	SB4	1	-	-
18	SB5	-	-	1
19	SB7	-	-	1
20	SB8	-	-	1
21	SB9	-	-	1
22	SB1	-	-	1
23	SB2	-	-	1
24	SB3	-	-	1
25	SB4	-	-	1
TOTALS		13	4	8

SIGNAL MOUNTING HARDWARE

	658.5070.01 SIGNAL MOUNTING HARDWARE
LOCATION	EACH
W GREENFIELD AVE & W BELOIT RD	1
TOTALS	1

SHEET 3 OF 4

INTERSECTION OF
W GREENFIELD AVE & W BELOIT RD
ALL ITEMS CATEGORY 0010

3

EMERGENCY VEHICLE PREEMPTION SYSTEM

SPV.0060.01

EMERGENCY VEHICLE
PREEMPTION SYSTEM

LOCATION	EACH
W GREENFIELD AVE & W BELOIT RD	1
TOTALS	1

APS PUSH BUTTON SYSTEM

SPV.0060.04
APS PUSH BUTTON
SYSTEM, 8 BUTTONS

LOCATION	EACH
W GREENFIELD AVE & W BELOIT RD	1
TOTALS	1

3

TRAFFIC SIGNAL CONTROLLER & CABINET

SPV.0060.05

TRAFFIC SIGNAL
CONTROLLER & CABINET

LOCATION	EACH
W GREENFIELD AVE & W BELOIT RD	1
TOTALS	1

VIDEO VEHICLE DETECTION SYSTEM

SPV.0060.06
VIDEO VEHICLE
DETECTION SYSTEM

LOCATION	EACH
W GREENFIELD AVE & W BELOIT RD	1
TOTALS	1

CAMERA	INSTALLATION METHOD
V1 (SB2)	ON LUMINAIRE ARM
V2 (SB6)	ON LUMINAIRE ARM
V3 (SB4)	ON LUMINAIRE ARM
V4 (SB9)	ON LUMINAIRE ARM

SHEET 4 OF 4

INTERSECTION OF
W GREENFIELD AVE & S 52ND ST
ALL ITEMS CATEGORY 0010

CONCRETE BASES

654.0101*

CONCRETE
BASES TYPE 1

BASE NO.	STATION	LOCATION	EACH
SB1	35+09.3	26.8' LT	1
SB2	35+66.7	25.5' RT	1
TOTALS			2

*ADDITIONAL QUANTITIES SHOWN ELSEWHERE

APS PUSH BUTTON SYSTEM

SPV.0060.02
APS PUSH BUTTON
SYSTEM, 4 BUTTONS

LOCATION	EACH
W GREENFIELD AVE & S 52ND ST	1
TOTALS	1

TRAFFIC SIGNAL CABLE

655.0230*

CABLE TRAFFIC
SIGNAL 5-14 AWG

FROM	TO	LF
B-11	RFB SB2	73
RFB SB2	B-12	68
B-12	RFB SB1	73
TOTALS		214

*ADDITIONAL QUANTITIES SHOWN ELSEWHERE

RECTANGULAR RAPID FLASHING BEACON SYSTEM

SPV.0060.07
RECTANGULAR RAPID
FLASHING BEACON SYSTEM

LOCATION	EACH
W GREENFIELD AVE & S 52ND ST	1
TOTALS	1

POLES AND ARMS

657.0100*

657.0425*

PEDESTAL
BASES
TRAFFIC SIGNAL
STANDARDS
ALUMINUM 15-FOOT

SIGNAL BASE NO.	EACH	EACH
SB1	1	1
SB2	1	1
TOTALS	2	2

*ADDITIONAL QUANTITIES SHOWN ELSEWHERE

INSTALLATION LOCATION SHOWN ON

RFB SB1	RAPID FLASHING BEACON PLAN
B-11	LIGHTING PLAN
B-12	LIGHTING PLAN
RFB SB2	RAPID FLASHING BEACON PLAN

SHEET 1 OF 1

CONCRETE BASES

654.0101*

CONCRETE
BASES TYPE 1

BASE NO.	STATION	LOCATION	EACH
SB3	37+76.1	25.0' LT	1
SB4	38+33.7	25.5' RT	1
TOTALS			2

*ADDITIONAL QUANTITIES SHOWN ELSEWHERE

APS PUSH BUTTON SYSTEM

SPV.0060.03
APS PUSH BUTTON
SYSTEM, 4 BUTTONS

LOCATION	EACH
W GREENFIELD AVE & S 51ST ST	1
TOTALS	1

TRAFFIC SIGNAL CABLE

655.0230*

CABLE TRAFFIC
SIGNAL 5-14 AWG

FROM	TO	LF
B-15	RFB SB3	83
RFB SB3	B-14	66
B-14	RFB SB4	73
TOTALS		222

*ADDITIONAL QUANTITIES SHOWN ELSEWHERE

RECTANGULAR RAPID FLASHING BEACON SYSTEM

SPV.0060.08
RECTANGULAR RAPID
FLASHING BEACON SYSTEM

LOCATION	EACH
W GREENFIELD AVE & S 51ST ST	1
TOTALS	1

POLES AND ARMS

657.0100*

657.0425*

PEDESTAL
BASES
TRAFFIC SIGNAL
STANDARDS
ALUMINUM 15-FOOT

SIGNAL BASE NO.	EACH	EACH
SB3	1	1
SB4	1	1
TOTALS	2	2

*ADDITIONAL QUANTITIES SHOWN ELSEWHERE

INSTALLATION LOCATION SHOWN ON

RFB SB3	RAPID FLASHING BEACON PLAN
B-14	LIGHTING PLAN
B-15	LIGHTING PLAN
RFB SB4	RAPID FLASHING BEACON PLAN

CONVENTIONAL SYMBOLS	
SECTION LINE	---
QUARTER LINE	---
SIXTEENTH LINE	---
NEW REFERENCE LINE	---
NEW R/W LINE	---
EXISTING R/W OR HE LINE	---
PROPERTY LINE	---
LOT, TIE & OTHER MINOR LINES	---
SLOPE INTERCEPT	---
CORPORATE LIMITS	---
UNDERGROUND FACILITY (COMMUNICATIONS, ELECTRIC, ETC)	---
NEW R/W (FEE OR HE) (HATCHING VARIES BY OWNER)	---
TEMPORARY LIMITED EASEMENT AREA	---
EASEMENT AREA (PERMANENT LIMITED OR RESTRICTED DEVELOPMENT)	---
TRANSMISSION STRUCTURES	---
BUILDING TO BE REMOVED	---
BRIDGE	---
CULVERT	---
SECTION CORNER SYMBOL	---
SECTION CORNER MONUMENT	---
GEODETIC SURVEY MONUMENT	---
SIXTEENTH CORNER MONUMENT	---
SIGN	---
OFF-PREMISE SIGN	---
R/W MONUMENT (TO BE SET)	---
NON-MONUMENTED R/W POINT	---
FOUND IRON PIN (1-INCH UNLESS NOTED)	---
COMPENSABLE	---
NON-COMPENSABLE	---
ELECTRIC POLE	---
TELEPHONE POLE	---
PEDESTAL (LABEL TYPE) (TV, TEL, ELEC, ETC.)	---
ACCESS RESTRICTED BY ACQUISITION	---
NO ACCESS (BY STATUTORY AUTHORITY)	---
ACCESS RESTRICTED (BY PREVIOUS PROJECT OR CONTROL)	---
NO ACCESS (NEW HIGHWAY)	---
PARCEL NUMBER	---
UTILITY NUMBER	---
PARALLEL OFFSETS	---

CONVENTIONAL UTILITY SYMBOLS	
WATER	---
GAS	---
TELEPHONE	---
OVERHEAD TRANSMISSION LINES	---
ELECTRIC	---
CABLE TELEVISION	---
FIBER OPTIC	---
SANITARY SEWER	---
STORM SEWER	---
ELECTRIC TOWER	---

CONVENTIONAL ABBREVIATIONS			
ACCESS RIGHTS	AR	POINT OF COMPOUND CURVE	PCC
ACRES	AC	POINT OF INTERSECTION	PI
AHEAD	AH	PROPERTY LINE	PL
ALUMINUM	ALUM	RECORDED AS (100')	(100')
AND OTHERS	ET AL	REEL / IMAGE	R/I
BACK	BK	REFERENCE LINE	R/L
BLOCK	BLK	REMAINING	REM
CENTERLINE	C/L	RESTRICTIVE DEVELOPMENT EASEMENT	RDE
CERTIFIED SURVEY MAP	CSM		
CONCRETE	CONC	RIGHT	RT
COUNTY	CO	RIGHT OF WAY	R/W
COUNTY TRUNK HIGHWAY	CTH	SECTION	SEC
DISTANCE	DIST	SEPTIC VENT	SEPV
CORNER	COR	SQUARE FEET	SF
DOCUMENT NUMBER	DOC	STATE TRUNK HIGHWAY	STH
EASEMENT	EASE	STATION	STA
EXISTING	EX	TELEPHONE PEDESTAL	TP
GAS VALVE	GV	TEMPORARY LIMITED EASEMENT	TLE
GRID NORTH	GN		
HIGHWAY EASEMENT	HE	TRANSPORTATION PROJECT PLAT	TPP
IDENTIFICATION	ID	UNITED STATES HIGHWAY	USH
LAND CONTRACT	LC	VOLUME	V
LEFT	LT		
MONUMENT	MON		
NATIONAL GEODETIC SURVEY NUMBER	NGS		
OUTLOT	OL		
PAGE	P		
POINT OF TANGENCY	PT		
PERMANENT LIMITED EASEMENT	PLE		
POINT OF BEGINNING	POB		
POINT OF CURVATURE	PC		

CURVE DATA ABBREVIATIONS			
LONG CHORD	LCH		
LONG CHORD BEARING	LCB		
RADIUS	R		
DEGREE OF CURVE	D		
CENTRAL ANGLE	Δ/DELTA		
LENGTH OF CURVE	L		
TANGENT	T		
DIRECTION AHEAD	DA		
DIRECTION BACK	DB		

NOTES:
 COORDINATES ARE BASED ON THE WISCONSIN STATE PLANE COORDINATE SYSTEM, SOUTH ZONE 4803, NORTH AMERICAN DATUM OF 1927 (NAD27), CONVERTED TO GROUND USING COMBINATION REDUCTION FACTOR OF 0.99992192.

ALL NEW RIGHT-OF-WAY MONUMENTS WILL BE TYPE 2 (TYPICALLY 3/4" X 24" IRON REBARS), UNLESS OTHERWISE NOTED.

ALL RIGHT-OF-WAY LINES DEPICTED IN THE NON-ACQUISITION AREAS ARE INTENDED TO RE-ESTABLISH EXISTING RIGHT-OF-WAY LINES AS DETERMINED FROM PREVIOUS PROJECTS, OTHER RECORDED DOCUMENTS, OR FROM CENTERLINE OF EXISTING PAVEMENTS.

DIMENSIONING FOR THE NEW RIGHT-OF-WAY IS MEASURED ALONG AND PERPENDICULAR TO THE NEW REFERENCE LINES.

RIGHT-OF-WAY BOUNDARIES ARE DEFINED WITH COURSES OF THE PERIMETER OF THE HIGHWAY LANDS REFERENCED TO THE U.S. PUBLIC LAND SURVEY SYSTEM OR OTHER "SURVEYS" OF PUBLIC RECORD.

FOR THE CURRENT ACCESS/DRIVEWAY INFORMATION, CONTACT THE PLANNING UNIT OF THE WISCONSIN DEPARTMENT OF TRANSPORTATION OFFICE IN WAUKESHA, WISCONSIN.

PARCEL AND UTILITY IDENTIFICATION NUMBERS MAY NOT POINT TO ALL AREAS OF ACQUISITION, AS NOTED ON THE DETAIL PAGES.

INFORMATION FOR THE BASIS OF EXISTING HIGHWAY RIGHT-OF-WAY POINTS OF REFERENCE AND ACCESS CONTROL ARE LISTED ON THE DETAIL PAGES.

A TEMPORARY LIMITED EASEMENT (TLE) IS A RIGHT FOR CONSTRUCTION PURPOSES, AS DEFINED HEREIN, INCLUDING THE RIGHT TO OPERATE NECESSARY EQUIPMENT THEREON, THE RIGHT OF INGRESS AND EGRESS, AS LONG AS REQUIRED FOR SUCH PUBLIC PURPOSE, INCLUDING THE RIGHT TO PRESERVE, PROTECT, REMOVE, OR PLANT THEREON ANY VEGETATION THAT THE HIGHWAY AUTHORITIES MAY DEEM DESIRABLE. ALL (TLEs) ON THIS PLAT EXPIRE AT THE COMPLETION OF THE CONSTRUCTION PROJECT FOR WHICH THIS INSTRUMENT IS GIVEN.

PROPERTY LINES SHOWN ON THIS PLAT ARE DRAWN FROM DATA DERIVED FROM MAPS AND DOCUMENTS OF PUBLIC RECORD AND/OR EXISTING OCCUPATIONAL LINES. THIS PLAT MAY NOT BE A TRUE REPRESENTATION OF EXISTING PROPERTY LINES, EXCLUDING RIGHT-OF-WAY, AND SHOULD NOT BE USED AS A SUBSTITUTE FOR AN ACCURATE FIELD SURVEY.

R/W PROJECT NUMBER 2230-07-03	SHEET NUMBER 4.01	TOTAL SHEETS 15
FEDERAL PROJECT NUMBER		
PLAT OF RIGHT OF WAY REQUIRED FOR V WEST MILWAUKEE W GREENFIELD AVENUE S 56TH STREET TO MILLER PARK WAY		
W. GREENFIELD AVENUE		MILWAUKEE CO.
CONSTRUCTION PROJECT NUMBER 2230-07-73		

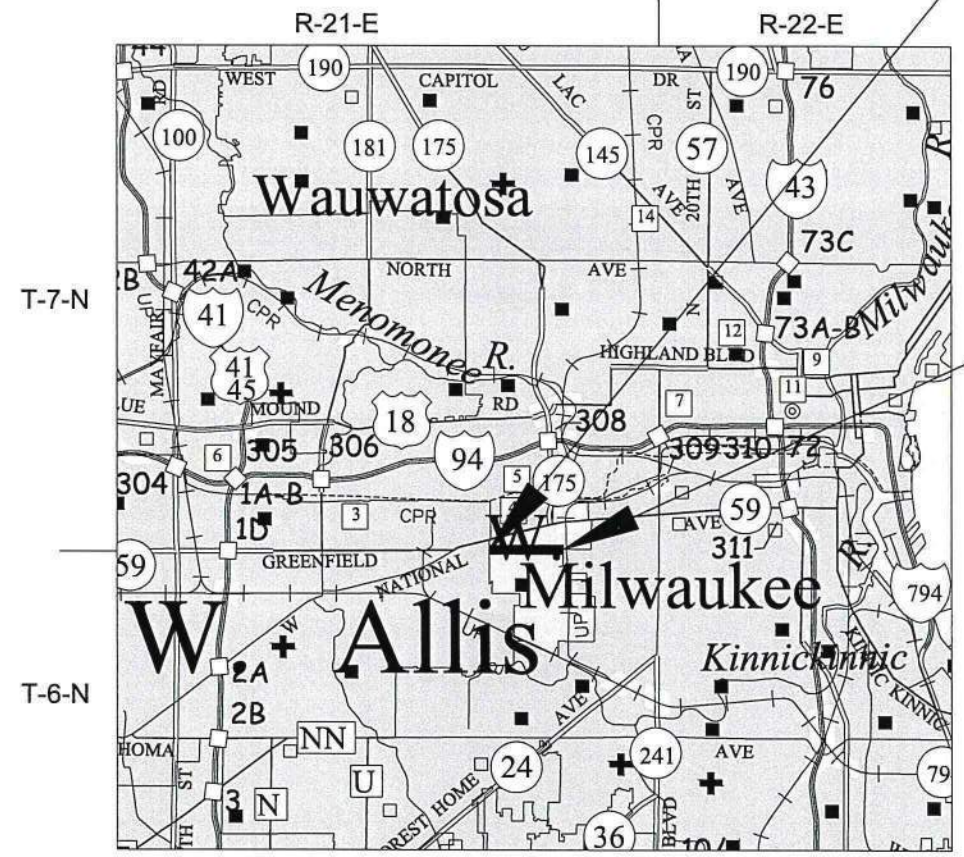

BEGIN RELOCATION ORDER
 1.01 FT SOUTH AND 1327.10 FT EAST OF THE SOUTHWEST CORNER OF SEC. 35, T7N., R21E.
 Y= 377132.80
 X= 2539937.95

END RELOCATION ORDER
 0.01 FT SOUTH AND 69.27 FT WEST OF THE SOUTHWEST CORNER OF SEC. 35, T7N., R21E.
 Y= 377251.83
 X= 2543643.29

THIS PLAT IS A GRAPHIC REPRESENTATION AND IS FOR REFERENCE PURPOSES ONLY. DEEDS MUST BE CHECKED TO DETERMINE PROPERTY BOUNDARIES AND ACCESS RIGHTS.

ORIGINAL PLANS PREPARED BY

GRÄEF

275 W. WISCONSIN AVENUE, SUITE 300
MILWAUKEE, WI 53203

CARLA J. ROLLINS
S-3207
SHEBOYGAN, WI

LAND SURVEYOR

04/23/2022 *Carla J. Rollins*
(Date) (Signature)

REVISION DATE	VILLAGE OF WEST MILWAUKEE
APPROVED FOR THE VILLAGE DATE: 9-28-22 <i>Kai Sun</i> (Signature)	

TOTAL NET LENGTH OF CENTERLINE = 0.746 MI

SCHEDULE OF LANDS & INTERESTS REQUIRED

AREAS SHOWN IN THE TOTAL ACRES COLUMN MAY BE APPROXIMATE AND ARE DERIVED FROM TAX ROLLS OR OTHER AVAILABLE SOURCES AND MAY NOT INCLUDE LANDS OF THE OWNER WHICH ARE NOT CONTIGUOUS TO THE AREA TO BE ACQUIRED.

PARCEL NUMBER	SHEET NUMBER	OWNER(S)	INTEREST REQUIRED	TOTAL ACRES	R/W REQUIRED (ACRES OR S.F.)			REMAINING ACRES	P.L.E. ACRES	T.L.E. ACRES
					NEW	EXISTING	TOTAL			
1	4.08	RUTH H. KRESSL, A SINGLE INDIVIDUAL	TLE	0.121	0.000	0.000	0.000	0.121	0.000	0.022
2	4.08	ST. JOHN'S EVANGELICAL LUTHERAN CHURCH	TLE	0.458	0.000	0.000	0.000	0.458	0.000	0.019
3	4.08	ST. JOHN'S EVANGELICAL LUTHERAN CHURCH OF WEST ALLIS, ALSO KNOWN AS ST. JOHN'S EVANGELICAL LUTHERAN CHURCH, AS ST. JOHN'S EV. LUTHERAN CHURCH, AS ST. JOHN'S EVANGELICAL LUTHERAN CONGREGATION AND AS ST. JOHN'S EVANGELICAL LUTHERAN CONGREGATION OF WEST ALLIS, WISCONSIN	TLE	0.220	0.000	0.000	0.000	0.220	0.000	0.007
4	4.08	ST. JOHN'S EVANGELICAL LUTHERAN CHURCH OF WEST ALLIS, ALSO KNOWN AS ST. JOHN'S EVANGELICAL LUTHERAN CHURCH, AS ST. JOHN'S EV. LUTHERAN CHURCH, AS ST. JOHN'S EVANGELICAL LUTHERAN CONGREGATION AND AS ST. JOHN'S EVANGELICAL LUTHERAN CONGREGATION OF WEST ALLIS, WISCONSIN	TLE	0.202	0.000	0.000	0.000	0.202	0.000	0.007
5	4.08	MATTHEW SOKOLOWICZ	TLE	0.193	0.000	0.000	0.000	0.193	0.000	0.008
6	4.08	LORRAINE SHELLAUGH	TLE	0.113	0.000	0.000	0.000	0.113	0.000	0.010
7	4.08	RONALD E ENGLISH, III, TIMOTHY CREED	TLE	0.107	0.000	0.000	0.000	0.107	0.000	0.008
8	4.08	MICHAEL AREND, A SINGLE MAN AND GREG SMITH, A MARRIED MAN AND VALERIE HITE-SMITH, HIS WIFE	TLE	0.108	0.000	0.000	0.000	0.108	0.000	0.011
9	4.08	SOL INVESTING LLC	TLE	0.108	0.000	0.000	0.000	0.108	0.000	0.005
10	4.08	55TH ST, LLC	TLE	0.192	0.000	0.000	0.000	0.192	0.000	0.011
11	4.08	ROBERT A. THOMPSON, TRUSTEE OF THE ROBERT A. THOMPSON SURVIVOR'S TRUST DATED DECEMBER 2, 2016, AS AMENDED OR RESTATED	TLE	0.151	0.000	0.000	0.000	0.151	0.000	0.006
12	4.09	GREENFIELD 54, LLC	TLE	0.331	0.000	0.000	0.000	0.331	0.000	0.028
13	4.09	K.B. CO. 5320 LLC	TLE	0.434	0.000	0.000	0.000	0.434	0.000	0.018
14	4.09	LEHONG TRAN, OR HER SUCCESSOR, TRUSTEE OF THE LEHONG TRAN TRUST DATED JANUARY 26, 2017	TLE	0.106	0.000	0.000	0.000	0.106	0.000	0.009
15	4.09	TARA ANH TRAN CORK	TLE	0.113	0.000	0.000	0.000	0.113	0.000	0.009
16	4.09	SEVEN PAW PROPERTIES LLC	TLE	0.150	0.000	0.000	0.000	0.150	0.000	0.006
17	4.09	LISA A. THOMPSON	TLE	0.119	0.000	0.000	0.000	0.119	0.000	0.018
18	4.09	ROBERT F. PROSTEK	TLE	0.328	0.000	0.000	0.000	0.328	0.000	0.022
19	4.09	FELICIANA, LLC	TLE	0.109	0.000	0.000	0.000	0.109	0.000	0.009
20	4.09	FELICIANA, LLC	TLE	0.109	0.000	0.000	0.000	0.109	0.000	0.009
21	4.09	RHODES PROPERTY MANAGERS LLC, A WISCONSIN LIMITED LIABILITY COMPANY	TLE	0.107	0.000	0.000	0.000	0.107	0.000	0.009
22	4.10	K.B. CO. 1745 LLC	TLE	0.108	0.000	0.000	0.000	0.108	0.000	0.006
23	4.10	ROSALVA GOMEZ AND ILARITA SANCHEZ	TLE	0.109	0.000	0.000	0.000	0.109	0.000	0.006
24	4.10	CHRISTIAN A. GARRIDO	TLE	0.109	0.000	0.000	0.000	0.109	0.000	0.009
25	4.10	STEPHANIE M. ROIX AND MICHAEL W. MILEY	TLE	0.109	0.000	0.000	0.000	0.109	0.000	0.008
26	4.10	JAIME NUNEZ, A SINGLE INDIVIDUAL	TLE	0.109	0.000	0.000	0.000	0.109	0.000	0.008
27	4.10	PABLO ORTIZ AND MARIA ORTIZ, HUSBAND AND WIFE	TLE	0.108	0.000	0.000	0.000	0.108	0.000	0.008
28	4.10	SCHOOL DISTRICT OF WEST ALLIS, WEST MILWAUKEE, ET AL, A UNIFIED SCHOOL DISTRICT ORGANIZED AND EXISTING UNDER CHAPTER 120, SUBCHAPTER III, WISCONSIN STATUTES	TLE	5.371	0.000	0.000	0.000	5.371	0.000	0.148
29	4.10	TANYA M. ROSALES	TLE	0.110	0.000	0.000	0.000	0.110	0.000	0.011
30	4.10	LAURA L. FORCIA, TRUSTEE OF THE JERRY MCROY TRUST DATED OCTOBER 1, 2016	TLE	0.109	0.000	0.000	0.000	0.109	0.000	0.011

4

4

REVISION DATE	_____	_____	_____	_____
_____	_____	_____	_____	_____
_____	_____	_____	_____	_____

DATE	06/23/2022
GRID FACTOR	_____



HWY:	W. GREENFIELD AVENUE
COUNTY:	MILWAUKEE

STATE R/W PROJECT NUMBER:	2230-07-03
CONSTRUCTION PROJECT NUMBER:	2230-07-73

PLAT SHEET	4.02
PS&E SHEET	_____

E

SCHEDULE OF LANDS & INTERESTS REQUIRED

AREAS SHOWN IN THE TOTAL ACRES COLUMN MAY BE APPROXIMATE AND ARE DERIVED FROM TAX ROLLS OR OTHER AVAILABLE SOURCES AND MAY NOT INCLUDE LANDS OF THE OWNER WHICH ARE NOT CONTIGUOUS TO THE AREA TO BE ACQUIRED.

PARCEL NUMBER	SHEET NUMBER	OWNER(S)	INTEREST REQUIRED	TOTAL ACRES	R/W REQUIRED (ACRES OR S.F.)			REMAINING ACRES	P.L.E. ACRES	T.L.E. ACRES
					NEW	EXISTING	TOTAL			
31	4.10	JEFFREY S. VOGELER	TLE	0.109	0.000	0.000	0.000	0.109	0.000	0.011
32	4.10	ARACELI ROBLES ESTRADA	TLE	0.109	0.000	0.000	0.000	0.109	0.000	0.011
33	4.10	RIGOBERTO CAXNAJOY	TLE	0.109	0.000	0.000	0.000	0.109	0.000	0.011
34	4.10	ANNE M SALBASHIAN, A SINGLE PERSON AND MARK R ZUBE, A SINGLE PERSON	TLE	0.107	0.000	0.000	0.000	0.107	0.000	0.011
35	4.10	RONALD J. KLEMENT, JR.	TLE	0.115	0.000	0.000	0.000	0.115	0.000	0.014
36	4.10	JORGE MEJIA	TLE	0.114	0.000	0.000	0.000	0.114	0.000	0.014
37	4.10	ANTHONY L. JOHNSON, A SINGLE PERSON	TLE	0.114	0.000	0.000	0.000	0.114	0.000	0.014
38	4.10	RAMON ENCINO AND VITA ENCINO, HUSBAND AND WIFE	TLE	0.110	0.000	0.000	0.000	0.110	0.000	0.009
39	4.10	JENNIFER A. STEPHAN	TLE	0.114	0.000	0.000	0.000	0.114	0.000	0.009
40	4.11	CHARLOTTE BUSKA, AS TO A LIFE ESTATE, TORRI R. ROCKFORD AND TERIL J. BUCK, THE REMAINDER INTEREST AS TENANTS IN COMMON	TLE	0.151	0.000	0.000	0.000	0.151	0.000	0.008
41	4.11	REFUGIO CASTRO AND EDUVIGES CASTRO, HUSBAND AND WIFE	TLE	0.073	0.000	0.000	0.000	0.073	0.000	0.011
42	4.11	SCHROEDER PROPERTY INVESTMENTS LLC	TLE	0.073	0.000	0.000	0.000	0.073	0.000	0.003
43	4.11	MARSHALL T. MANEY	TLE	0.110	0.000	0.000	0.000	0.110	0.000	0.005
44	4.11	THOMAS P. BODENBACH AND MICHELLE M. BODENBACH, HUSBAND AND WIFE AS SURVIVORSHIP MARITAL PROPERTY	TLE	0.134	0.000	0.000	0.000	0.134	0.000	0.011
45	4.11	HARRY F. FEDIKOVICH AND SHEILA FEDIKOVICH, HUSBAND AND WIFE AND HARRY FEDIKOVICH, JR.	TLE	0.110	0.000	0.000	0.000	0.110	0.000	0.005
46	4.11	JOSE MEJIA AND ANA LUCIA MEJIA HUSBAND AND WIFE	TLE	0.110	0.000	0.000	0.000	0.110	0.000	0.005
47	4.11	BRADLEY JROLF, A SINGLE PERSON	TLE	0.117	0.000	0.000	0.000	0.117	0.000	0.007
48	4.11	GABRIELA CABRERA	TLE	0.154	0.000	0.000	0.000	0.154	0.000	0.016
49	4.11	PATRICK M. FARDAL	TLE	0.067	0.000	0.000	0.000	0.067	0.000	0.011
50	4.11	JNF ENTERPRISES LLC	TLE	0.291	0.000	0.000	0.000	0.291	0.000	0.010
51	4.11	VILLAGE OF WEST MILWAUKEE	TLE	0.086	0.000	0.000	0.000	0.086	0.000	0.011
52	4.12	MARSHALL T. MANEY	TLE	0.083	0.000	0.000	0.000	0.083	0.000	0.003
53	4.12	GARY J. KARABELAS AND CAROL A. KARABELAS, HUSBAND AND WIFE, JOINT TENANTS WITH RIGHTS OF SURVIVORSHIP	TLE	0.138	0.000	0.000	0.000	0.138	0.000	0.006
54	4.12	KRYSTINE K KOIKE, A SINGLE INDIVIDUAL	TLE	0.106	0.000	0.000	0.000	0.106	0.000	0.001
55	4.12	JOHN P. THRALL OR PAMELA A. THRALL, TRUSTEES OF THE THRALL JOINT REVOCABLE TRUST DATED MAY 8, 2017	TLE	0.086	0.000	0.000	0.000	0.086	0.000	0.007
56	4.12	TEDDY J. KNIPRATH, SR., A MARRIED INDIVIDUAL	TLE	0.094	0.000	0.000	0.000	0.094	0.000	0.015
57	4.12	S13TH STREET LLC	TLE	0.286	0.000	0.000	0.000	0.286	0.000	0.024
58	4.12	VILLAGE OF WEST MILWAUKEE, A MUNICIPAL CORPORATION	TLE	0.069	0.000	0.000	0.000	0.069	0.000	0.014
59	4.12, 4.13 & 4.14	REXNORD INDUSTRIES, LLC	TLE	56.024	0.000	0.000	0.000	56.024	0.000	0.144
60	4.13	VILLAGE OF WEST MILWAUKEE, A MUNICIPAL CORPORATION	TLE	0.619	0.000	0.000	0.000	0.619	0.000	0.020

4

4

REVISION DATE	DATE 06/23/2022	SCALE, FEET	HWY: W. GREENFIELD AVENUE	STATE R/W PROJECT NUMBER: 2230-07-03	PLAT SHEET 4.03
	GRID FACTOR		COUNTY: MILWAUKEE	CONSTRUCTION PROJECT NUMBER: 2230-07-73	PS&E SHEET

SCHEDULE OF LANDS & INTERESTS REQUIRED

AREAS SHOWN IN THE TOTAL ACRES COLUMN MAY BE APPROXIMATE AND ARE DERIVED FROM TAX ROLLS OR OTHER AVAILABLE SOURCES AND MAY NOT INCLUDE LANDS OF THE OWNER WHICH ARE NOT CONTIGUOUS TO THE AREA TO BE ACQUIRED.

PARCEL NUMBER	SHEET NUMBER	OWNER(S)	INTEREST REQUIRED	TOTAL ACRES	R/W REQUIRED (ACRES OR S.F.)			REMAINING ACRES	P.L.E. ACRES	T.L.E. ACRES
					NEW	EXISTING	TOTAL			
61	4.13	VILLAGE OF WEST MILWAUKEE, A MUNICIPAL CORPORATION	TLE	0.695	0.000	0.000	0.000	0.695	0.000	0.028
62	4.13	SCHOOL DISTRICT OF WEST ALLIS, WEST MILWAUKEE, ET AL, A UNIFIED SCHOOL DISTRICT ORGANIZED AND EXISTING UNDER CHAPTER 120, SUBCHAPTER III, WISCONSIN STATUTES	TLE	2.718	0.000	0.000	0.000	2.718	0.000	0.047
63	4.14	VIRUS ENTERPRISES LLC	TLE	0.242	0.000	0.000	0.000	0.242	0.000	0.012
64	4.14	K. GARCIA PROPERTIES LLC	FEE & TLE	0.381	0.001	0.000	0.001	0.380	0.000	0.019
65	4.14	VICTOR REMIREZ	FEE & TLE	0.081	0.001	0.000	0.001	0.080	0.000	0.003
66	4.14	VIRUS ENTERPRISES, LLC	FEE & TLE	0.081	0.001	0.000	0.001	0.080	0.000	0.003
67	4.14	ALFONSO GONZALEZ RUBALCABA AND LINDA GONZALEZ, TENANTS IN COMMON	TLE	0.101	0.000	0.000	0.000	0.101	0.000	0.013
68	4.14	TELECOM INTERNATIONAL SERVICES, LLC	TLE	0.081	0.000	0.000	0.000	0.081	0.000	0.006
69	4.14	GUARDIAN CREDIT UNION	FEE & TLE	1.245	0.006	0.000	0.006	1.239	0.000	0.091
70	4.14	TARGET CORPORATION, A MINNESOTA CORPORATION	FEE & TLE	9.252	0.010	0.000	0.010	9.242	0.000	0.054
71	4.14, 4.15	MBG HOLDINGS, LLC, A WISCONSIN LIMITED LIABILITY COMPANY	FEE & TLE	0.811	0.005	0.000	0.005	0.806	0.000	0.024
72	4.15	GULFVIEW 305, LLC	TLE	0.081	0.000	0.000	0.000	0.081	0.000	0.006
73	4.15	ANNE M ZUBE	FEE & TLE	0.083	0.001	0.000	0.001	0.082	0.000	0.006
74	4.15	GULFVIEW 305, LLC	FEE & TLE	0.141	0.002	0.000	0.002	0.139	0.000	0.009
75	4.15	WEST MILWAUKEE APARTMENTS	FEE & TLE	3.995	0.011	0.000	0.011	3.984	0.000	0.043
76	4.15	WEST MILWAUKEE APARTMENTS	FEE & TLE	0.499	0.002	0.000	0.002	0.497	0.000	0.034
77	4.15	GULFVIEW 305, LLC	FEE & TLE	1.059	0.007	0.000	0.007	1.052	0.000	0.034
78	4.15	ARC CAFEUSA001, LLC	FEE & TLE	0.730	0.013	0.000	0.013	0.717	0.000	0.033
500	4.08, 4.11, 4.13, 4.14 & 4.15	WE ENERGIES ELECTRIC	RELEASE OF RIGHTS							
501	4.08, 4.13 & 4.15	AT&T	RELEASE OF RIGHTS							

4

4

REVISION DATE	DATE 06/23/2022	SCALE, FEET	HWY: W. GREENFIELD AVENUE	STATE R/W PROJECT NUMBER: 2230-07-03	PLAT SHEET 4.04
	GRID FACTOR		COUNTY: MILWAUKEE	CONSTRUCTION PROJECT NUMBER: 2230-07-73	PS&E SHEET

4

4

VILLAGE

OF

WEST

MILWAUKEE

W. GREENFIELD AVENUE

STREET

STREET

STREET

STREET

S. 56TH

S. 55TH STREET

S. 54TH

S. 53RD

S. 52ND

25

30

35

SEE SHEET 4.06

PL 10/17/14.00

MATCH LINE

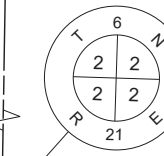
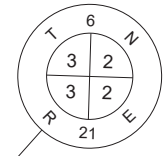
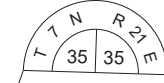
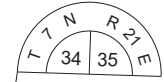
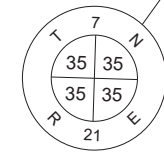
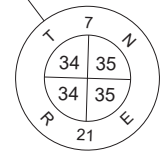

REVISION DATE	_____	_____	_____	_____
_____	_____	_____	_____	_____
_____	_____	_____	_____	_____

DATE: 06/23/2022

GRID FACTOR: _____

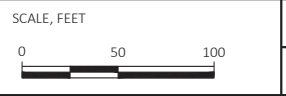

HWY: W. GREENFIELD AVENUE

COUNTY: MILWAUKEE

STATE R/W PROJECT NUMBER: 2230-07-03

CONSTRUCTION PROJECT NUMBER: 2230-07-73

PLAT SHEET 4.05

PS&E SHEET _____

E

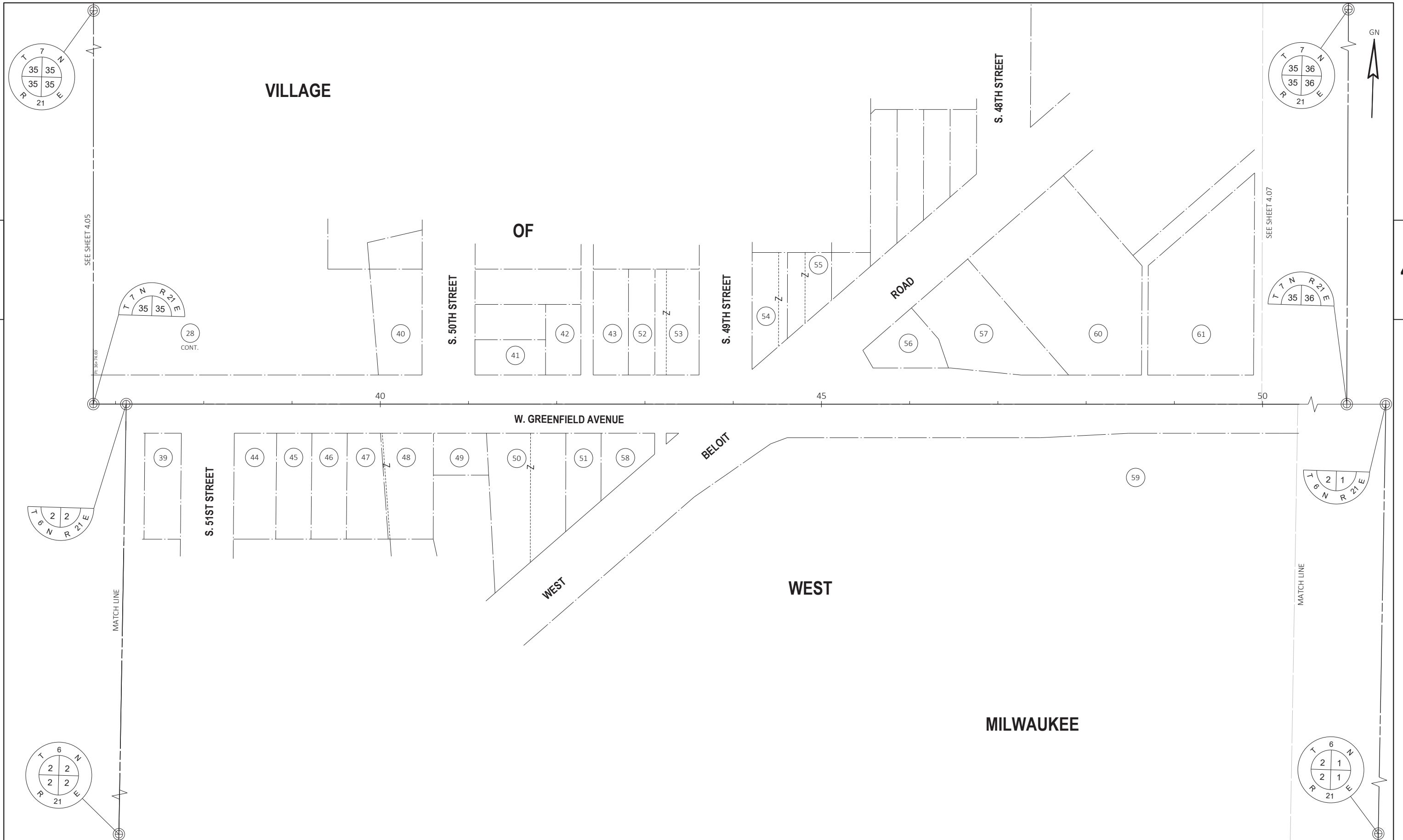

4

4

REVISION DATE	_____	_____	_____
_____	_____	_____	_____
_____	_____	_____	_____

DATE: 06/23/2022
 GRID FACTOR: _____

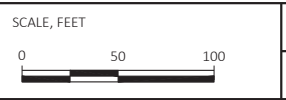

HWY: W. GREENFIELD AVENUE
 COUNTY: MILWAUKEE

STATE R/W PROJECT NUMBER: 2230-07-03
 CONSTRUCTION PROJECT NUMBER: 2230-07-73

PLAT SHEET 4.06
 PS&E SHEET _____

E

BASIS OF EXISTING RIGHT-OF-WAY		
ROUTE	BASIS	WIDTH
W. GREENFIELD AVENUE	BRACKEN BRAE GARDENS	66'
	ASSESSOR'S PLAT NO. 290	66'
	KINZFOGL'S ADDITION	66'
	GRUPPE ADDITION	66'
S. 56TH STREET	BRACKEN BRAE GARDENS	60'
	KINZFOGL'S ADDITION	60'
S. 55TH STREET	GRUPPE ADDITION	60'

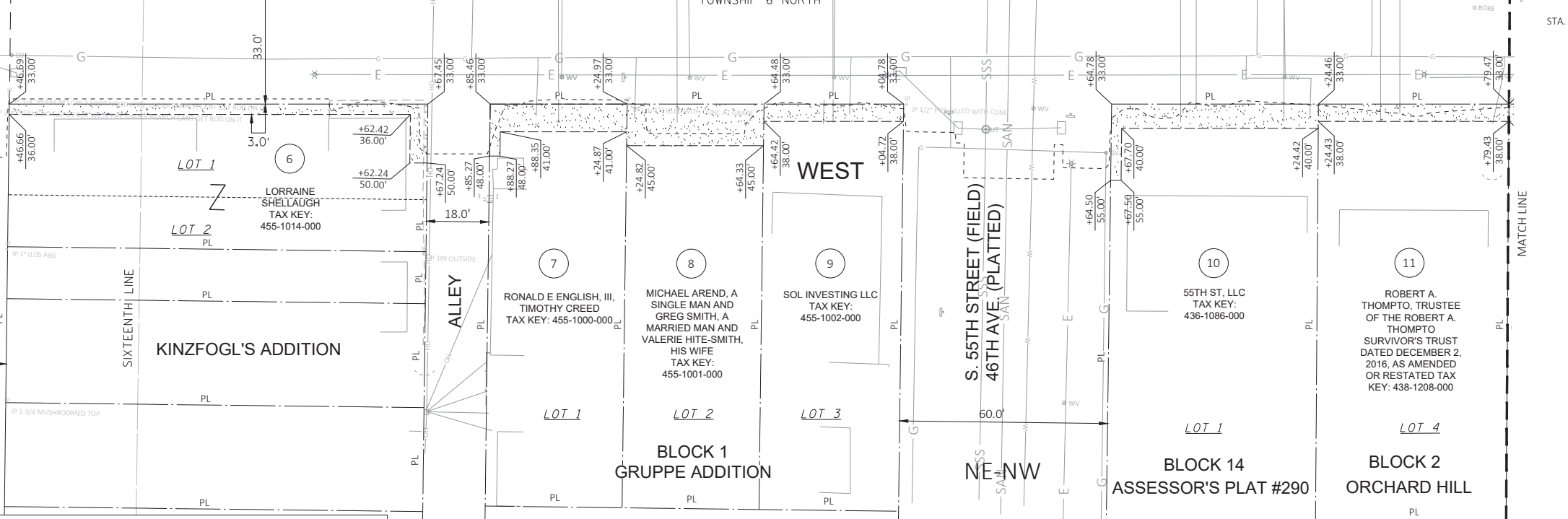
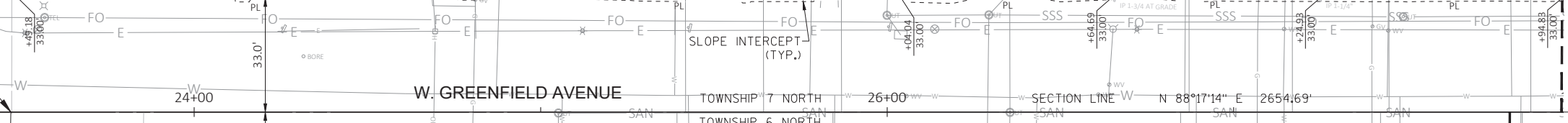
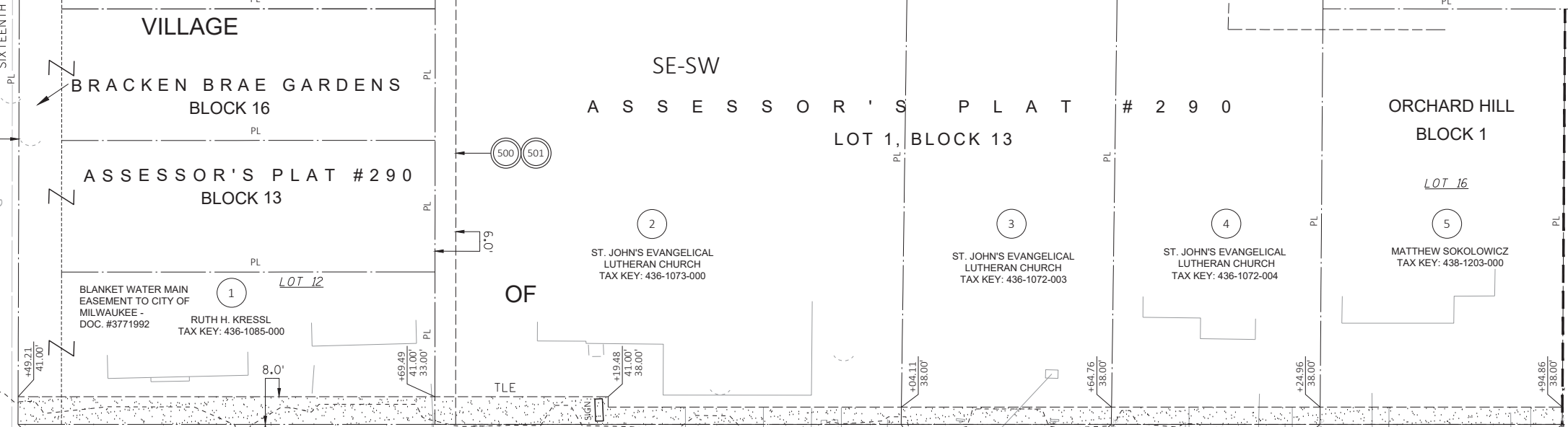

UTILITY TABLE				
UTILITY NO.	OWNER	WIDTH	DOCUMENT NO.	PARCEL
500	WE ENERGIES-ELECTRIC	6' UTILITY EASEMENT	3839760	2
501	AT&T	6' UTILITY EASEMENT	3839760	2

NOTE: THE TLE'S DO NOT INCLUDE ANY PART OF BUILDINGS

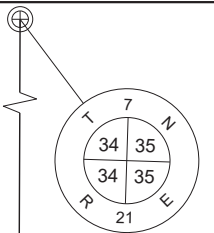

FOUND CONCRETE MONUMENT WITH SEWRPC BRASS CAP
Y=379772.97
X=2538339.96

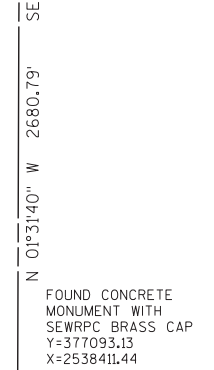

FOUND CONCRETE MONUMENT WITH SEWRPC BRASS CAP
Y=377093.13
X=2538411.44

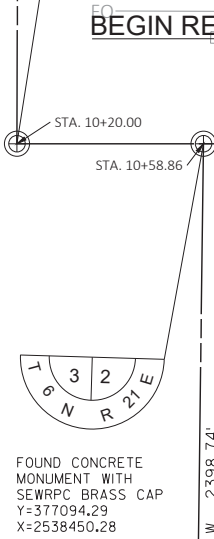

FOUND CONCRETE MONUMENT WITH SEWRPC BRASS CAP
Y=374695.91
X=2538450.28

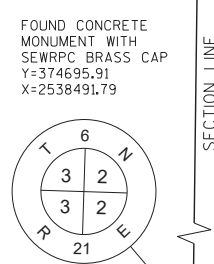

FOUND CONCRETE MONUMENT WITH SEWRPC BRASS CAP
Y=374757.45
X=2541135.39

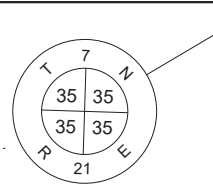

FOUND CONCRETE MONUMENT WITH SEWRPC BRASS CAP
Y=379844.14
X=2540984.57

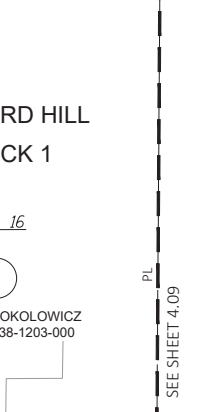

FOUND CONCRETE MONUMENT WITH SEWRPC BRASS CAP
Y=377172.48
X=2541064.94

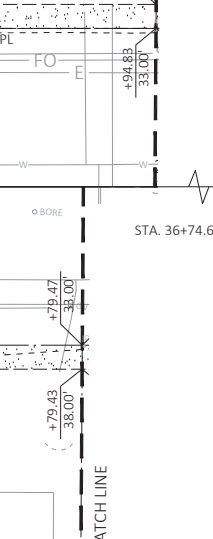

FOUND CONCRETE MONUMENT WITH SEWRPC BRASS CAP
Y=377173.63
X=2541102.28

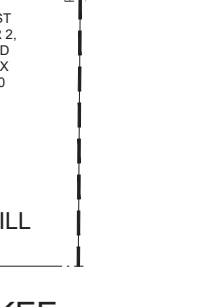

FOUND CONCRETE MONUMENT WITH SEWRPC BRASS CAP
Y=374757.45
X=2541135.39

REVISION DATE	DATE	SCALE, FEET	HWY: W. GREENFIELD AVENUE	STATE R/W PROJECT NUMBER: 2230-07-03	PLAT SHEET 4.08
	06/23/2022	0 20 40	COUNTY: MILWAUKEE	CONSTRUCTION PROJECT NUMBER: 2230-07-03	PS&E SHEET

GRID FACTOR	0.99992192
-------------	------------

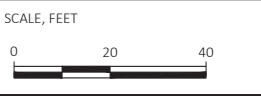

DATE: 06/23/2022
SCALE, FEET: 0 20 40
HWY: W. GREENFIELD AVENUE
COUNTY: MILWAUKEE

STATE R/W PROJECT NUMBER: 2230-07-03
CONSTRUCTION PROJECT NUMBER: 2230-07-03

PLAT SHEET 4.08
PS&E SHEET

BASIS OF EXISTING RIGHT-OF-WAY		
ROUTE	BASIS	WIDTH
W. GREENFIELD AVENUE	ORCHARD HILL	66'
	HILLVIEW	66'
S. 54TH STREET	ORCHARD HILL	60'
	HILLVIEW	60'
S. 53TH STREET	HILLVIEW	60'

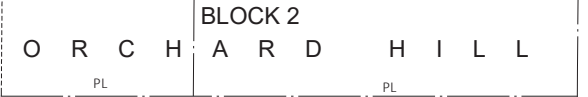
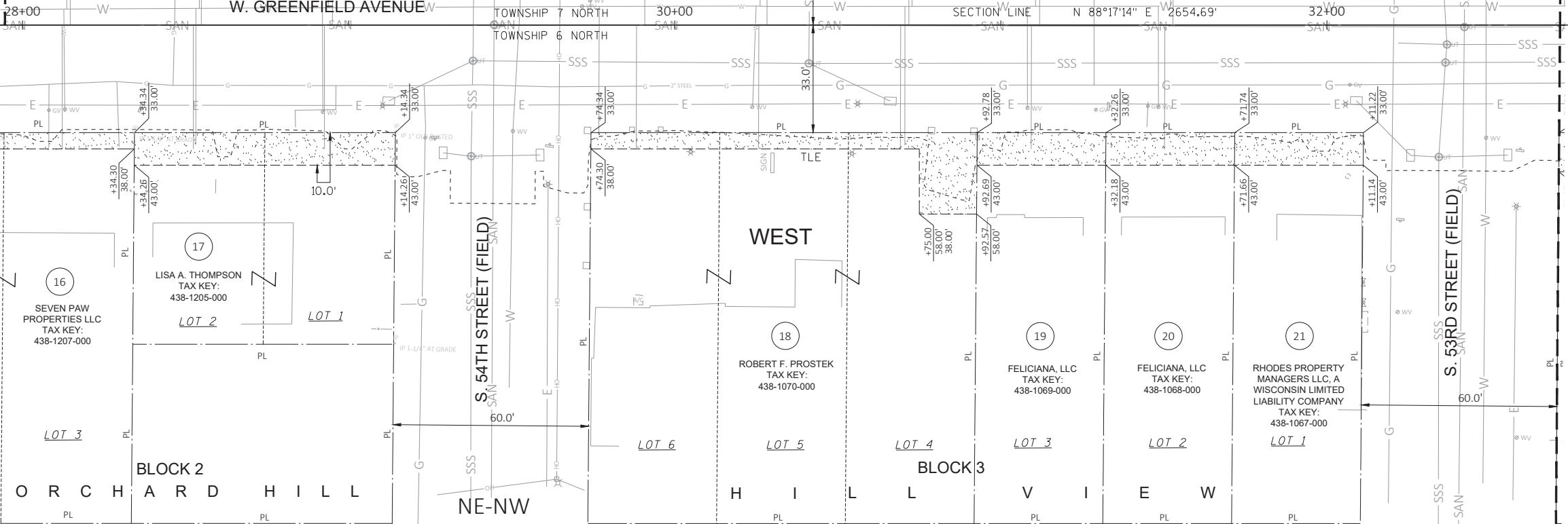
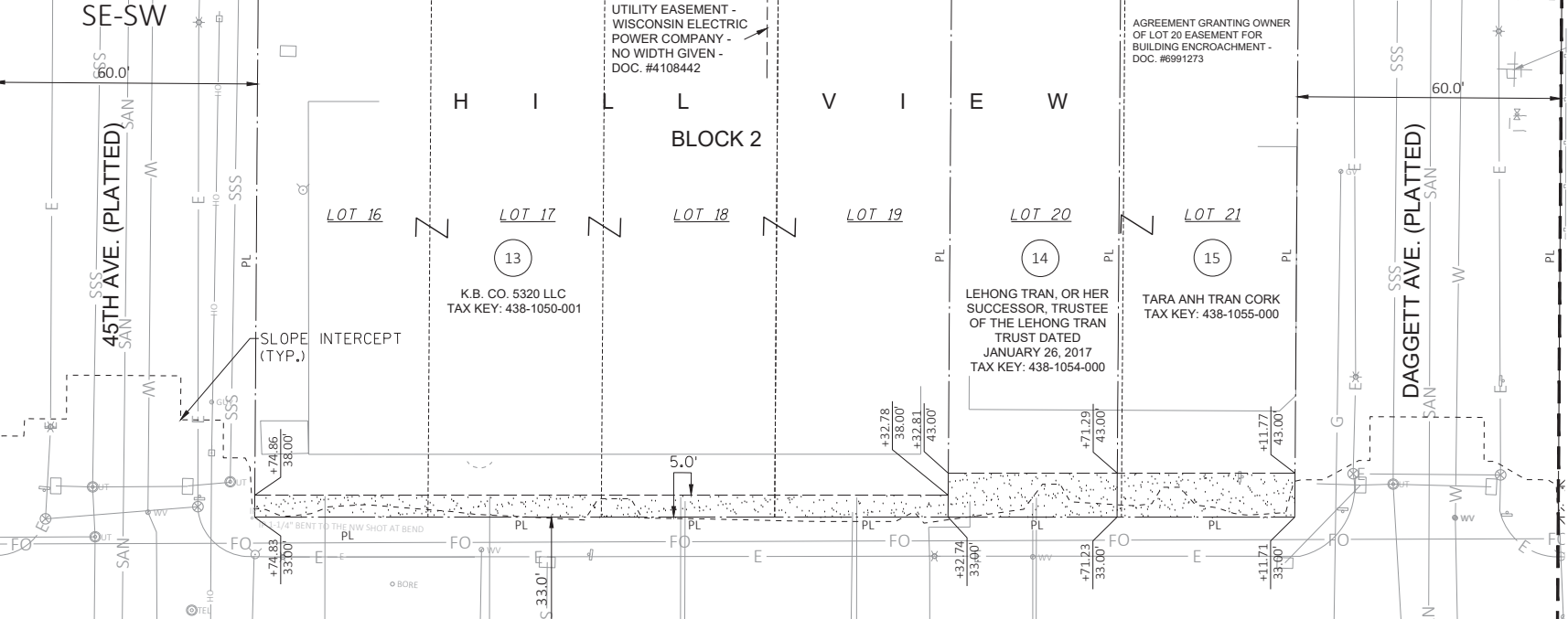
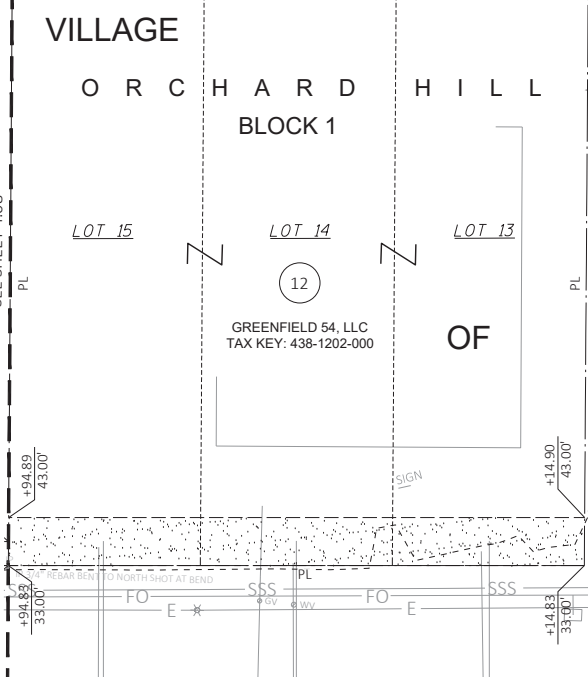

NOTE: THE TLE'S DO NOT INCLUDE ANY PART OF BUILDINGS

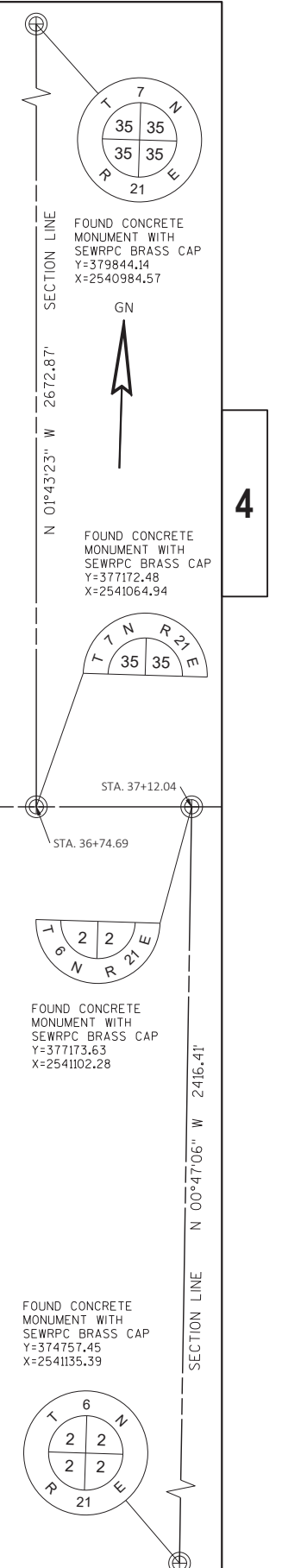
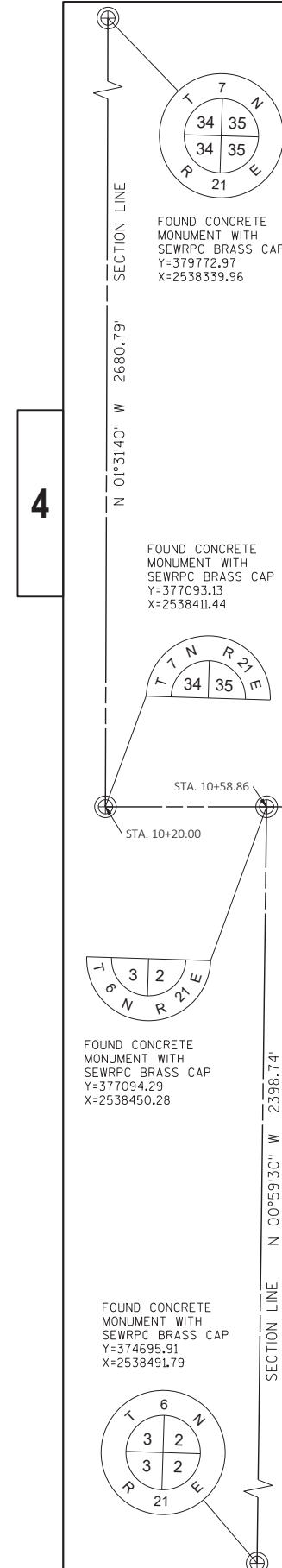

REVISION DATE	DATE	SCALE, FEET
	06/23/2022	0 20 40
	GRID FACTOR 0.99992192	

HWY: W. GREENFIELD AVENUE	STATE R/W PROJECT NUMBER: 2230-07-03	PLAT SHEET 4.09
COUNTY: MILWAUKEE	CONSTRUCTION PROJECT NUMBER: 2230-07-03	PS&E SHEET

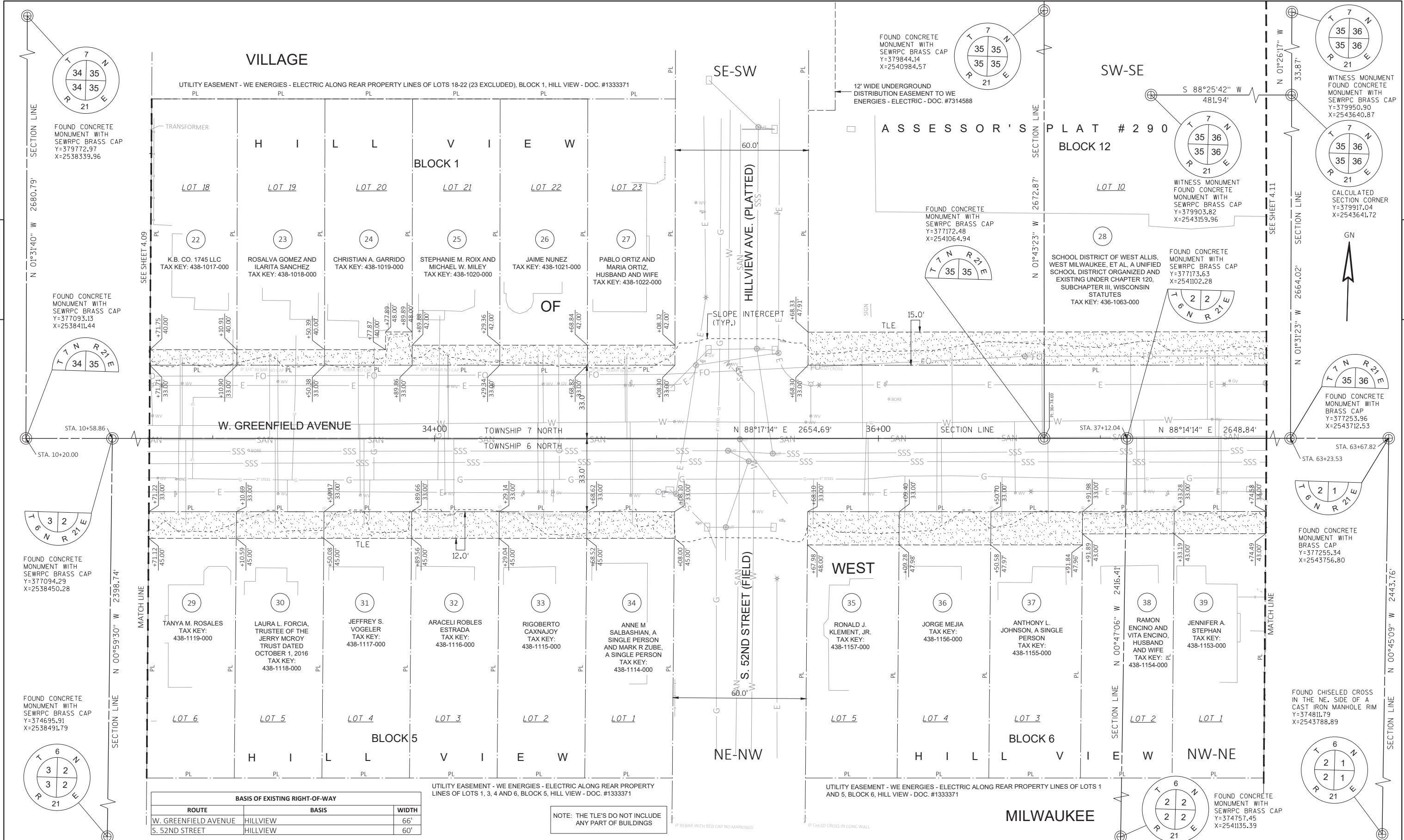

BASIS OF EXISTING RIGHT-OF-WAY		
ROUTE	BASIS	WIDTH
W. GREENFIELD AVENUE	HILLVIEW	66'
S. 52ND STREET	HILLVIEW	60'

NOTE: THE TLE'S DO NOT INCLUDE ANY PART OF BUILDINGS

REVISION DATE	DATE 06/23/2022
	GRID FACTOR 0.99992192

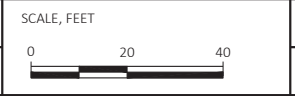

HWY: W. GREENFIELD AVENUE
 COUNTY: MILWAUKEE

STATE R/W PROJECT NUMBER: 2230-07-03
 CONSTRUCTION PROJECT NUMBER: 2230-07-03

PLAT SHEET 4.10
 PS&E SHEET **E**

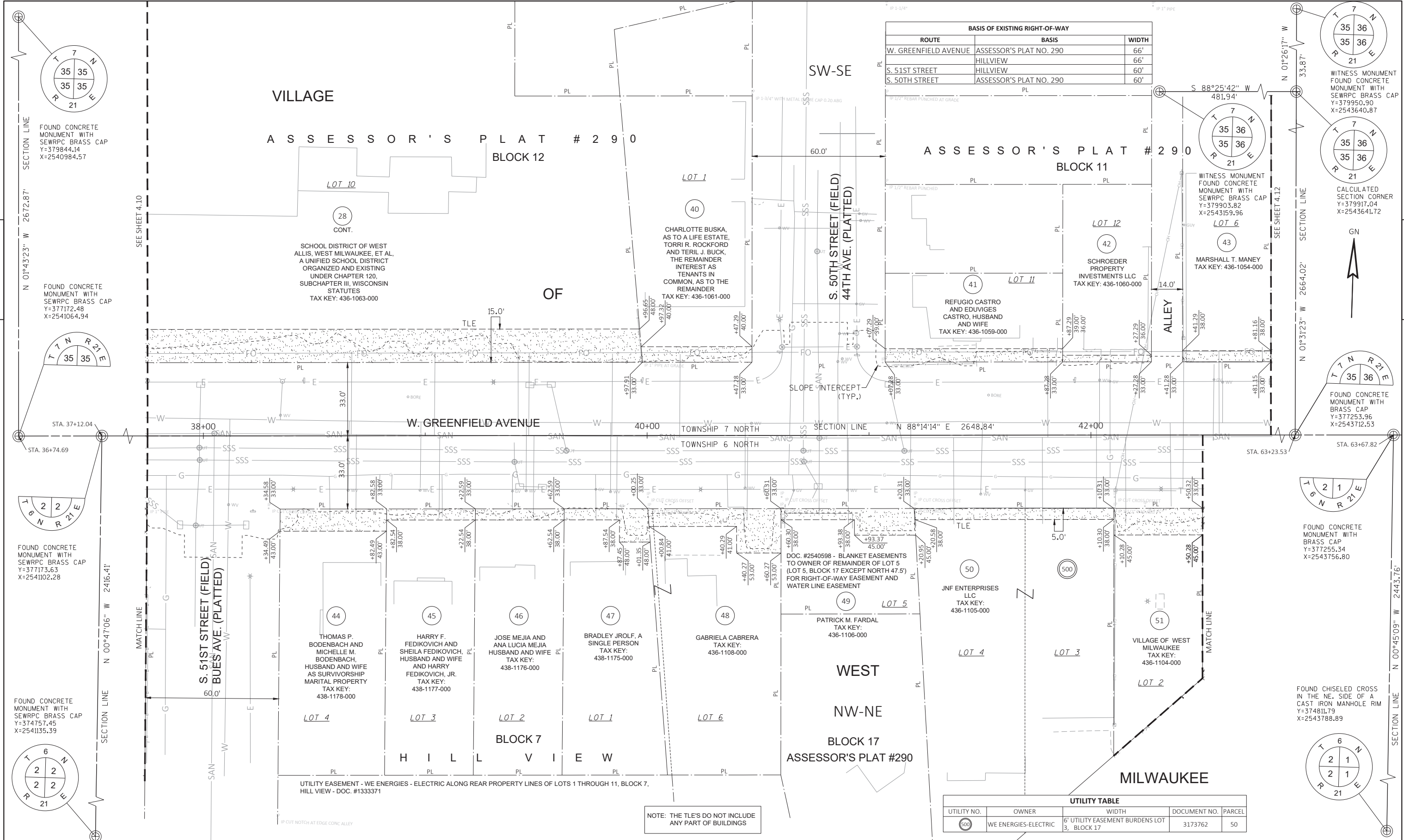

BASIS OF EXISTING RIGHT-OF-WAY		
ROUTE	BASIS	WIDTH
W. GREENFIELD AVENUE	ASSESSOR'S PLAT NO. 290	66'
S. 51ST STREET	HILLVIEW	66'
S. 50TH STREET	ASSESSOR'S PLAT NO. 290	60'

UTILITY TABLE				
UTILITY NO.	OWNER	WIDTH	DOCUMENT NO.	PARCEL
500	WE ENERGIES-ELECTRIC	6' UTILITY EASEMENT BURDENS LOT 3, BLOCK 17	3173762	50

NOTE: THE TLE'S DO NOT INCLUDE ANY PART OF BUILDINGS

UTILITY EASEMENT - WE ENERGIES - ELECTRIC ALONG REAR PROPERTY LINES OF LOTS 1 THROUGH 11, BLOCK 7, HILL VIEW - DOC. #1333371

3" P CUT NOTCH AT EDGE CONC. ALLEY

REVISION DATE	DATE	SCALE, FEET
	06/23/2022	0 20 40
	GRID FACTOR 0.99992192	

HWY: W. GREENFIELD AVENUE
 COUNTY: MILWAUKEE

STATE R/W PROJECT NUMBER: 2230-07-03
 CONSTRUCTION PROJECT NUMBER: 2230-07-03

PLAT SHEET 4.11
 PS&E SHEET E

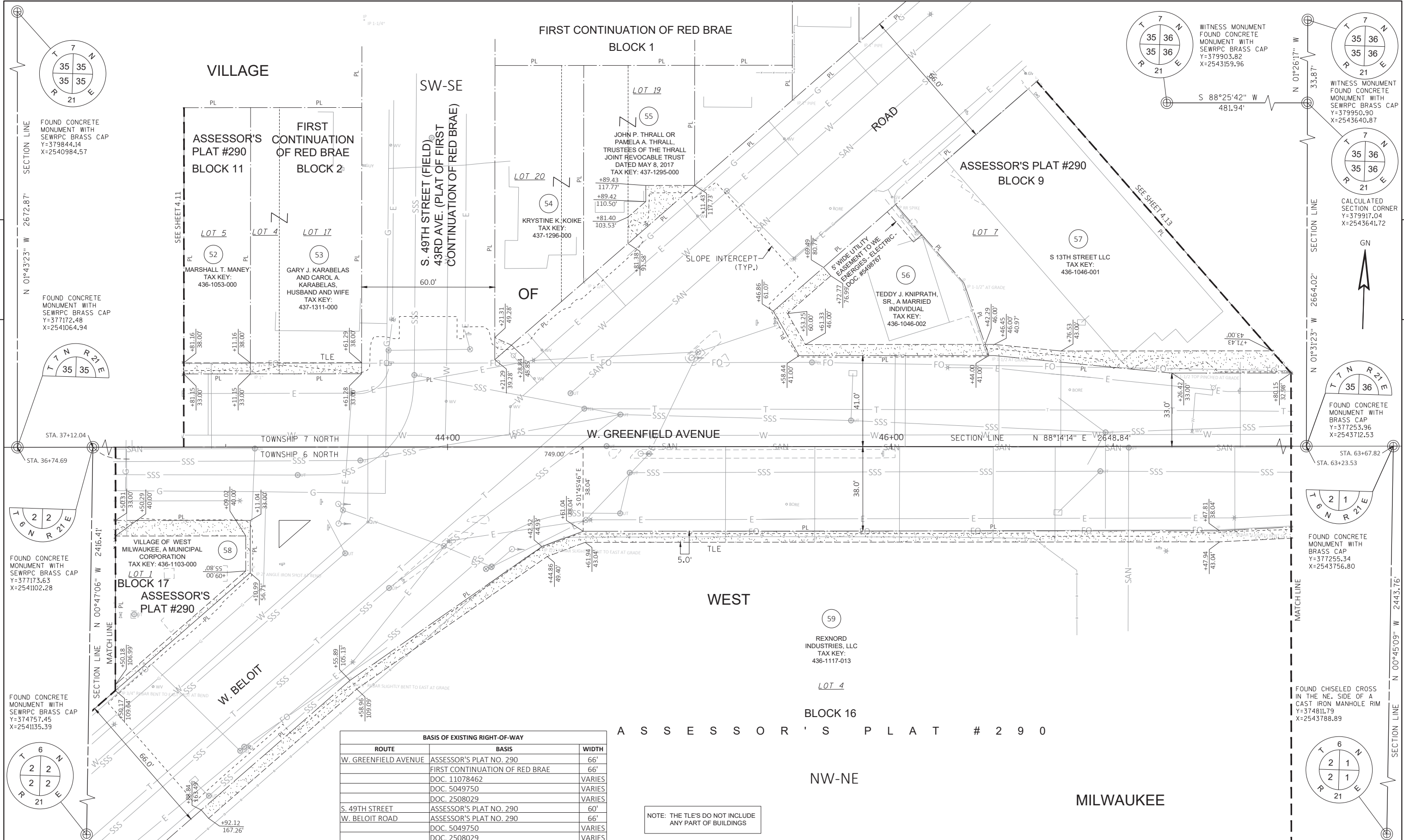

4

4

BASIS OF EXISTING RIGHT-OF-WAY		
ROUTE	BASIS	WIDTH
W. GREENFIELD AVENUE	ASSESSOR'S PLAT NO. 290	66'
	FIRST CONTINUATION OF RED BRAE	66'
	DOC. 11078462	VARIES
	DOC. 5049750	VARIES
	DOC. 2508029	VARIES
S. 49TH STREET	ASSESSOR'S PLAT NO. 290	60'
W. BELOIT ROAD	ASSESSOR'S PLAT NO. 290	66'
	DOC. 5049750	VARIES
	DOC. 2508029	VARIES

NOTE: THE TLE'S DO NOT INCLUDE ANY PART OF BUILDINGS

REVISION DATE	DATE 06/23/2022
	GRID FACTOR 0.99992192



HWY: W. GREENFIELD AVENUE
COUNTY: MILWAUKEE

STATE R/W PROJECT NUMBER: 2230-07-03
CONSTRUCTION PROJECT NUMBER: 2230-07-03

PLAT SHEET 4.12
PS&E SHEET E

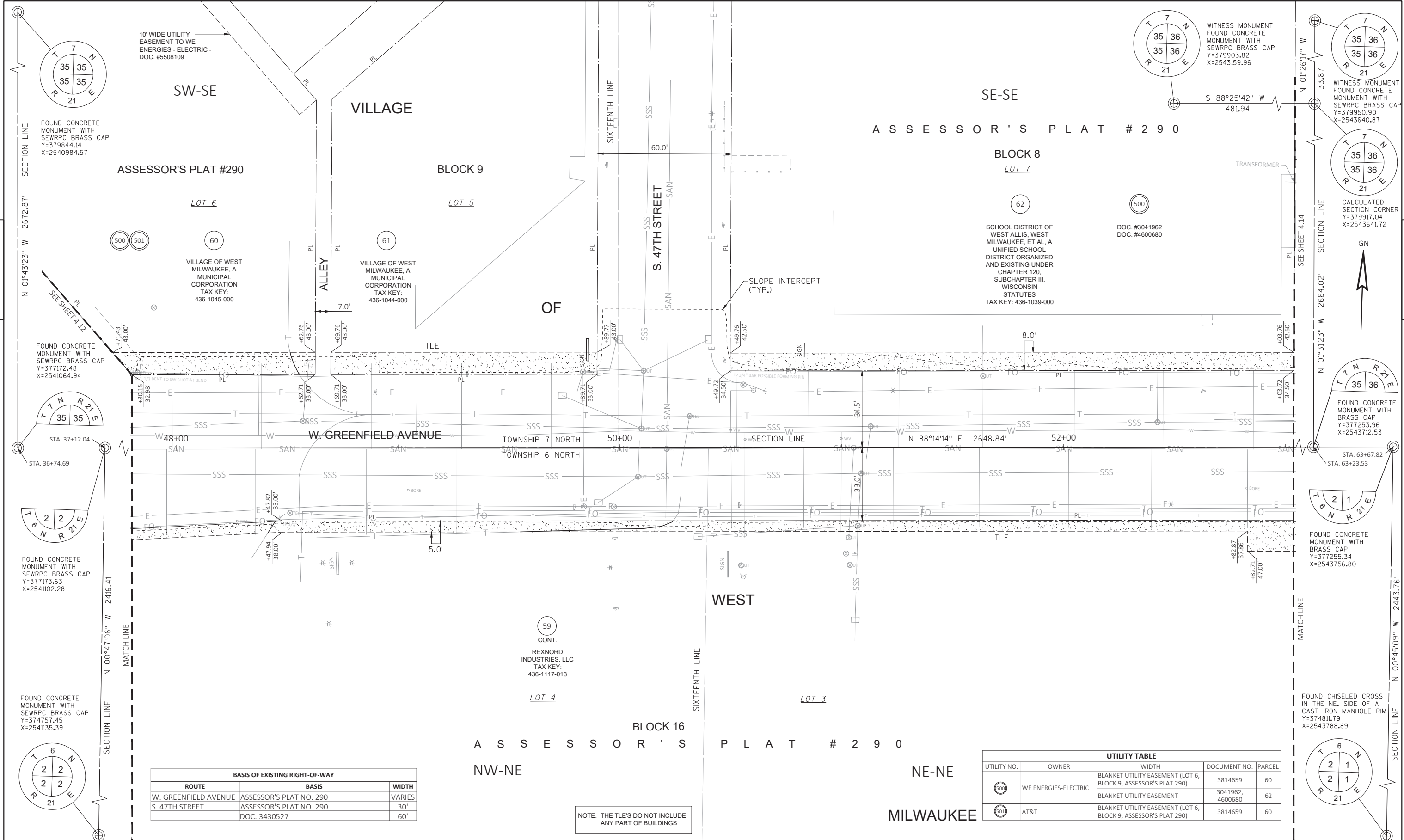

ASSESSOR'S PLAT #290

ASSESSOR'S PLAT # 290

BLOCK 8

BLOCK 9

BLOCK 16

ASSESSOR'S PLAT # 290

NW-NE

NE-NE

MILWAUKEE

BASIS OF EXISTING RIGHT-OF-WAY		
ROUTE	BASIS	WIDTH
W. GREENFIELD AVENUE	ASSESSOR'S PLAT NO. 290	VARIES
S. 47TH STREET	ASSESSOR'S PLAT NO. 290	30'
	DOC. 3430527	60'

NOTE: THE TLE'S DO NOT INCLUDE ANY PART OF BUILDINGS

UTILITY TABLE				
UTILITY NO.	OWNER	WIDTH	DOCUMENT NO.	PARCEL
500	WE ENERGIES-ELECTRIC	BLANKET UTILITY EASEMENT (LOT 6, BLOCK 9, ASSESSOR'S PLAT 290)	3814659	60
		BLANKET UTILITY EASEMENT	3041962, 4600680	62
501	AT&T	BLANKET UTILITY EASEMENT (LOT 6, BLOCK 9, ASSESSOR'S PLAT 290)	3814659	60

REVISION DATE	DESCRIPTION

DATE 06/23/2022

GRID FACTOR 0.99992192

SCALE, FEET



HWY: W. GREENFIELD AVENUE

COUNTY: MILWAUKEE

STATE R/W PROJECT NUMBER: 2230-07-03

CONSTRUCTION PROJECT NUMBER: 2230-07-03

PLAT SHEET 4.13

PS&E SHEET

E

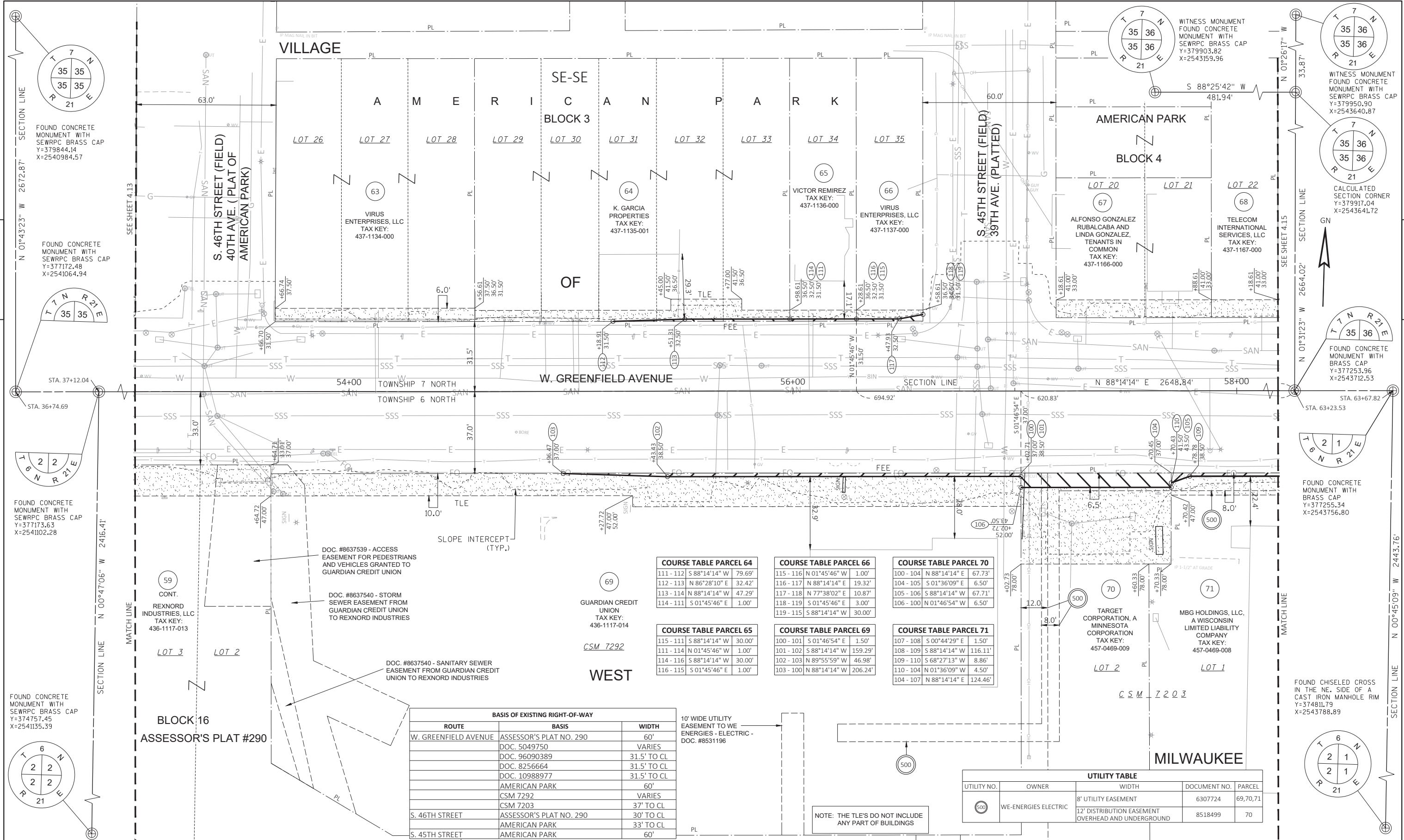

COURSE TABLE PARCEL 64

111 - 112	S 88°14'14" W	79.69'
112 - 113	N 86°28'10" E	32.42'
113 - 114	N 88°14'14" W	47.29'
114 - 111	S 01°45'46" E	1.00'

COURSE TABLE PARCEL 66

115 - 116	N 01°45'46" W	1.00'
116 - 117	N 88°14'14" W	19.32'
117 - 118	N 77°38'02" E	10.87'
118 - 119	S 01°45'46" E	3.00'
119 - 115	S 88°14'14" W	30.00'

COURSE TABLE PARCEL 70

100 - 104	N 88°14'14" E	67.73'
104 - 105	S 01°36'09" E	6.50'
105 - 106	S 88°14'14" W	67.71'
106 - 100	N 01°46'54" W	6.50'

COURSE TABLE PARCEL 65

115 - 111	S 88°14'14" W	30.00'
111 - 114	N 01°45'46" W	1.00'
114 - 116	S 88°14'14" W	30.00'
116 - 115	S 01°45'46" E	1.00'

COURSE TABLE PARCEL 69

100 - 101	S 01°46'54" E	1.50'
101 - 102	S 88°14'14" W	159.29'
102 - 103	N 89°55'59" W	46.98'
103 - 100	N 88°14'14" W	206.24'

COURSE TABLE PARCEL 71

107 - 108	S 00°44'29" E	1.50'
108 - 109	S 88°14'14" W	116.11'
109 - 110	S 68°27'13" W	8.86'
110 - 104	N 01°36'09" W	4.50'
104 - 107	N 88°14'14" E	124.46'

BASIS OF EXISTING RIGHT-OF-WAY

ROUTE	BASIS	WIDTH
W. GREENFIELD AVENUE	ASSESSOR'S PLAT NO. 290	60'
	DOC. 5049750	VARIES
	DOC. 96090389	31.5' TO CL
	DOC. 8256664	31.5' TO CL
	DOC. 10988977	31.5' TO CL
AMERICAN PARK		60'
	CSM 7292	VARIES
	CSM 7203	37' TO CL
S. 46TH STREET	ASSESSOR'S PLAT NO. 290	30' TO CL
	AMERICAN PARK	33' TO CL
S. 45TH STREET	AMERICAN PARK	60'

UTILITY TABLE

UTILITY NO.	OWNER	WIDTH	DOCUMENT NO.	PARCEL
500	WE-ENERGIES ELECTRIC	8' UTILITY EASEMENT 12' DISTRIBUTION EASEMENT OVERHEAD AND UNDERGROUND	6307724 8518499	69,70,71 70

NOTE: THE TLE'S DO NOT INCLUDE ANY PART OF BUILDINGS

REVISION DATE	DATE 06/23/2022	SCALE, FEET 0 20 40	HWY: W. GREENFIELD AVENUE	STATE R/W PROJECT NUMBER: 2230-07-03	PLAT SHEET 4.14
	GRID FACTOR 0.99992192		COUNTY: MILWAUKEE	CONSTRUCTION PROJECT NUMBER: 2230-07-03	PS&E SHEET

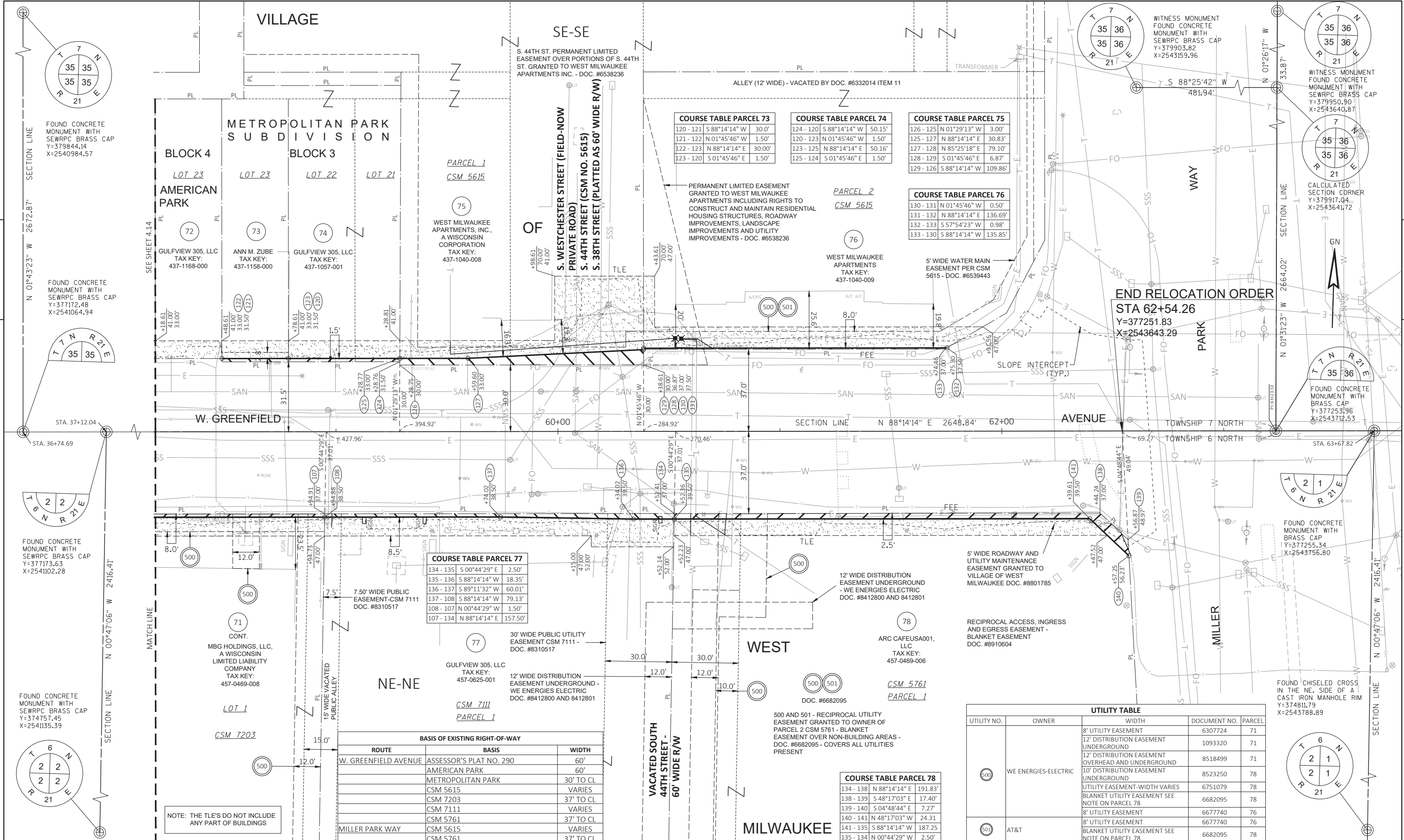

COURSE TABLE PARCEL 73			COURSE TABLE PARCEL 74			COURSE TABLE PARCEL 75		
120-121	S 88°14'14" W	30.0'	124-120	S 88°14'14" W	50.15'	126-125	N 01°29'13" W	3.00'
121-122	N 01°45'46" W	1.50'	120-123	N 01°45'46" W	1.50'	125-127	N 88°14'14" E	30.83'
122-123	N 88°14'14" E	30.00'	123-125	N 88°14'14" E	50.16'	127-128	N 85°25'18" E	79.10'
123-120	S 01°45'46" E	1.50'	125-124	S 01°45'46" E	1.50'	128-129	S 01°45'46" E	6.87'
						129-126	S 88°14'14" W	109.86'

COURSE TABLE PARCEL 76		
130-131	N 01°45'46" W	0.50'
131-132	N 88°14'14" E	136.69'
132-133	S 57°54'23" W	0.98'
133-130	S 88°14'14" W	135.85'

COURSE TABLE PARCEL 77		
134-135	S 00°44'29" E	2.50'
135-136	S 88°14'14" W	18.35'
136-137	S 89°11'32" W	60.01'
137-108	S 88°14'14" W	79.13'
108-107	N 00°44'29" W	1.50'
107-134	N 88°14'14" E	157.50'

COURSE TABLE PARCEL 78		
134-138	N 88°14'14" E	191.83'
138-139	S 48°17'03" E	17.40'
139-140	S 04°48'44" E	7.27'
140-141	N 48°17'03" W	24.31'
141-135	S 88°14'14" W	187.25'
135-134	N 00°44'29" W	2.50'

BASIS OF EXISTING RIGHT-OF-WAY		
ROUTE	BASIS	WIDTH
W. GREENFIELD AVENUE	ASSESSOR'S PLAT NO. 290	60'
AMERICAN PARK		60'
METROPOLITAN PARK		30' TO CL
CSM 5615		VARIES
CSM 7203		37' TO CL
CSM 7111		VARIES
CSM 5761		37' TO CL
MILLER PARK WAY		VARIES
CSM 5615		37' TO CL
CSM 5761		37' TO CL

UTILITY TABLE				
UTILITY NO.	OWNER	WIDTH	DOCUMENT NO.	PARCEL
500	WE ENERGIES-ELECTRIC	8' UTILITY EASEMENT UNDERGROUND	6307724	71
		12' DISTRIBUTION EASEMENT UNDERGROUND	1093320	71
		12' DISTRIBUTION EASEMENT OVERHEAD AND UNDERGROUND	8518499	71
		10' DISTRIBUTION EASEMENT UNDERGROUND	8523250	78
		UTILITY EASEMENT-WIDTH VARIES	6751079	78
		BLANKET UTILITY EASEMENT SEE NOTE ON PARCEL 78	6682095	78
		8' UTILITY EASEMENT	6677740	76
501	AT&T	8' UTILITY EASEMENT	6677740	76
		BLANKET UTILITY EASEMENT SEE NOTE ON PARCEL 78	6682095	78

NOTE: THE TLE'S DO NOT INCLUDE ANY PART OF BUILDINGS

REVISION DATE	DATE 06/23/2022	SCALE, FEET	HWY: W. GREENFIELD AVENUE	STATE R/W PROJECT NUMBER: 2230-07-03	PLAT SHEET 4.15
	GRID FACTOR 0.99992192	0 20 40	COUNTY: MILWAUKEE	CONSTRUCTION PROJECT NUMBER: 2230-07-03	PS&E SHEET

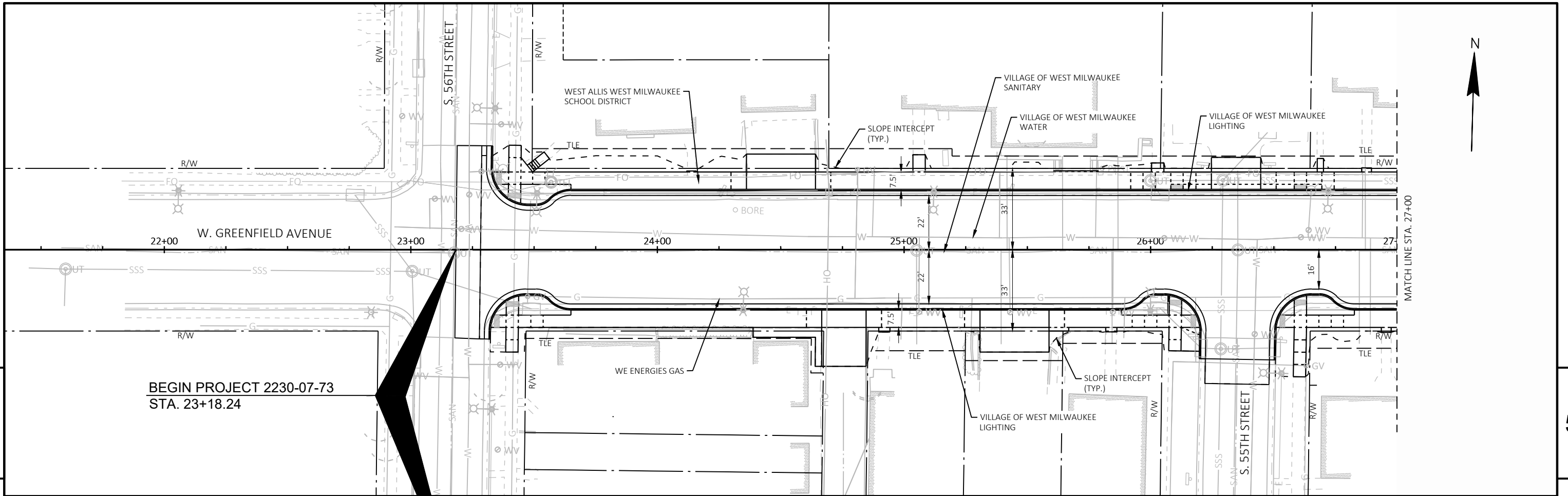

BEGIN PROJECT 2230-07-73
STA. 23+18.24

5

5

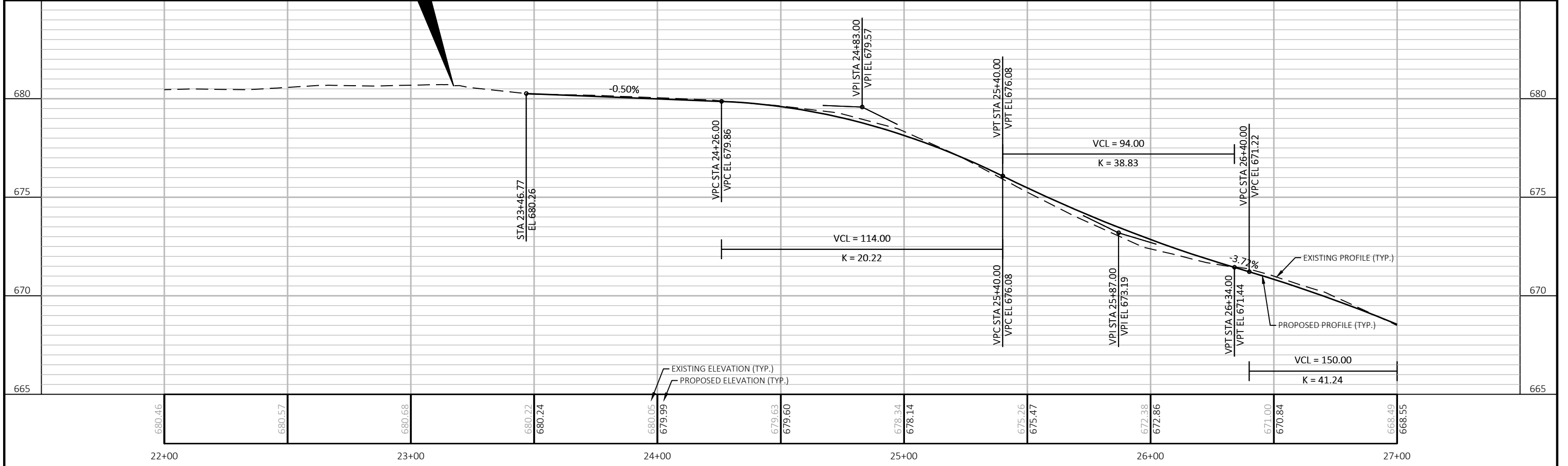

PROJECT NO: 2230-07-73	HWY: W. GREENFIELD AVENUE	COUNTY: MILWAUKEE	PLAN AND PROFILE	SHEET	E
------------------------	---------------------------	-------------------	------------------	-------	---

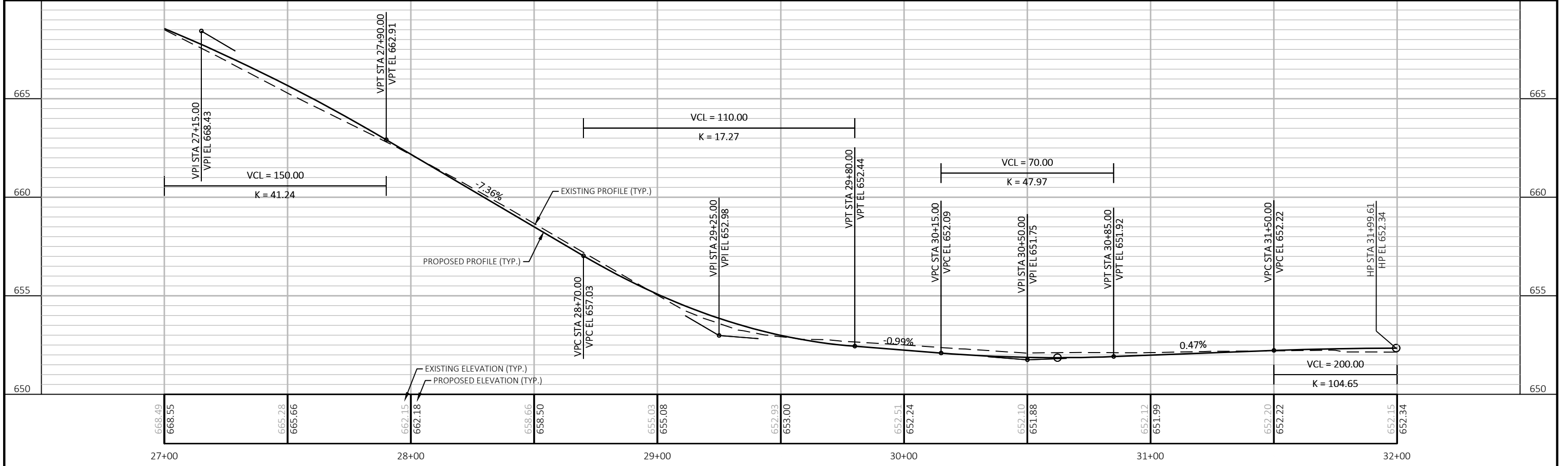
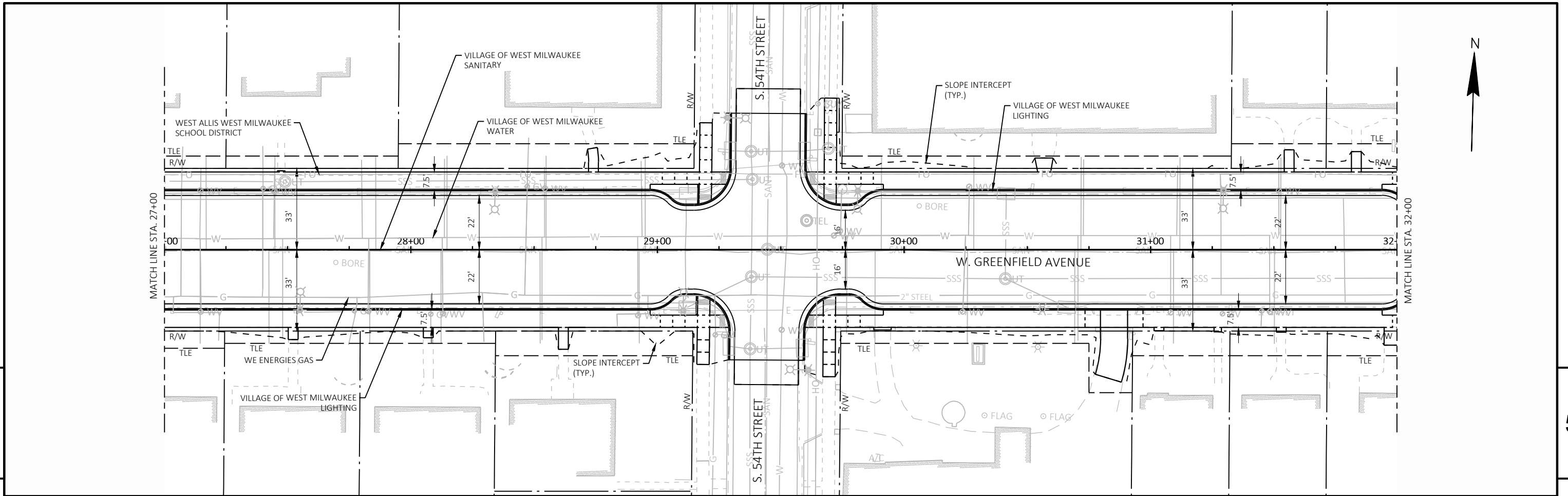

PROJECT NO: 2230-07-73	HWY: W. GREENFIELD AVENUE	COUNTY: MILWAUKEE	PLAN AND PROFILE	SHEET	E
------------------------	---------------------------	-------------------	------------------	-------	----------

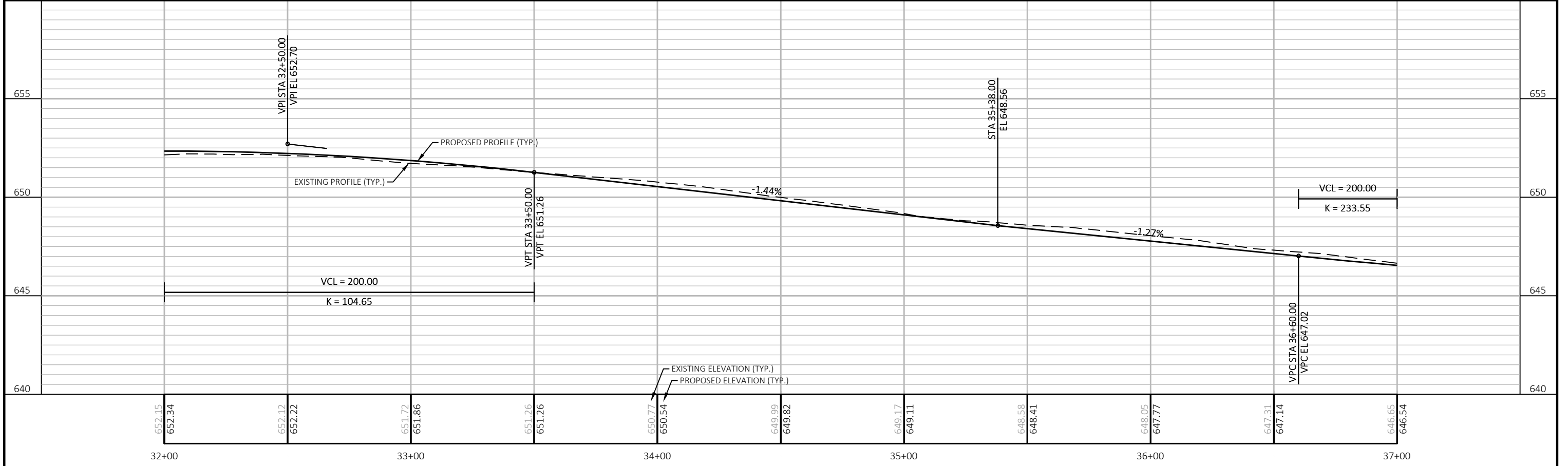
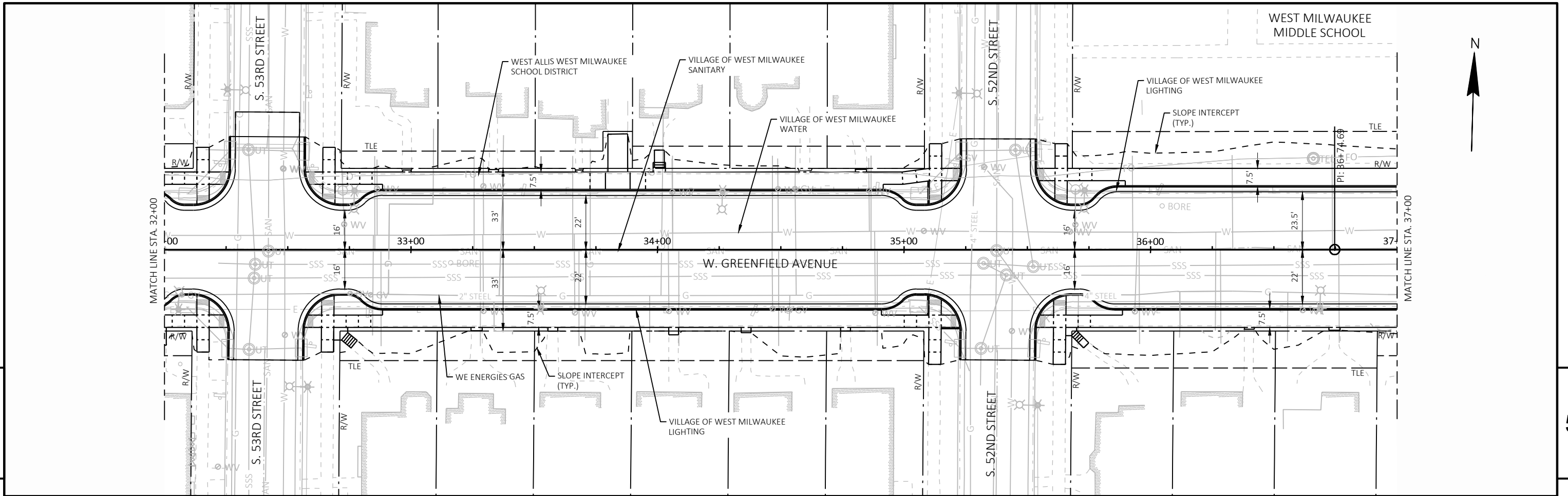

PROJECT NO: 2230-07-73 HWY: W. GREENFIELD AVENUE COUNTY: MILWAUKEE PLAN AND PROFILE SHEET E

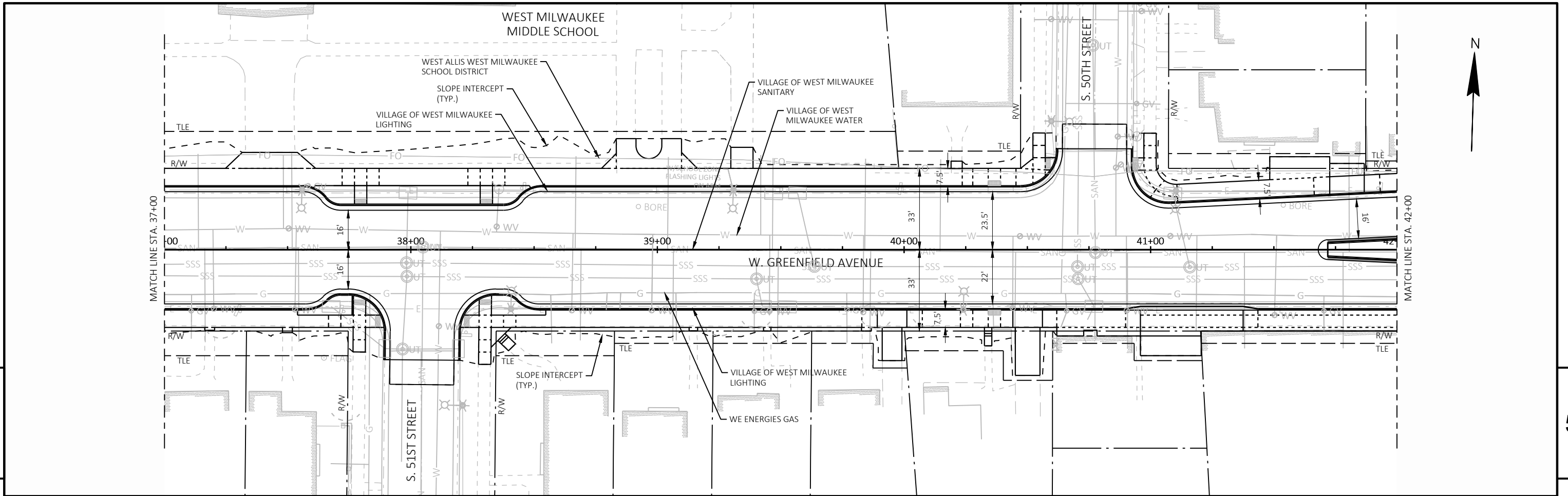

5

5

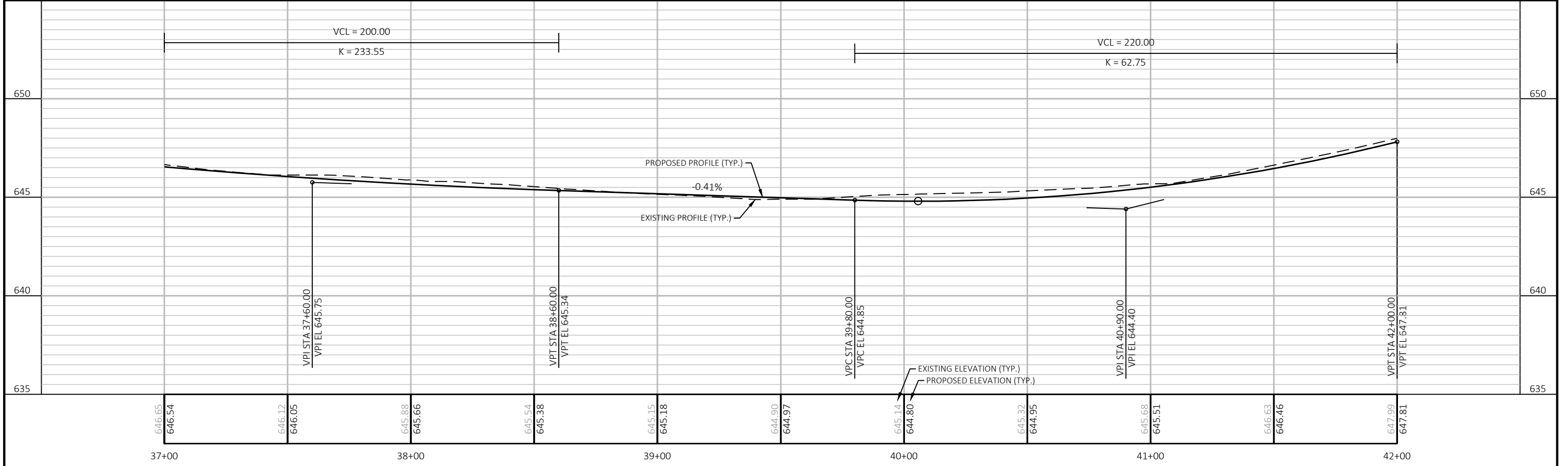

PROJECT NO: 2230-07-73	HWY: W. GREENFIELD AVENUE	COUNTY: MILWAUKEE	PLAN AND PROFILE	SHEET	E
------------------------	---------------------------	-------------------	------------------	-------	---

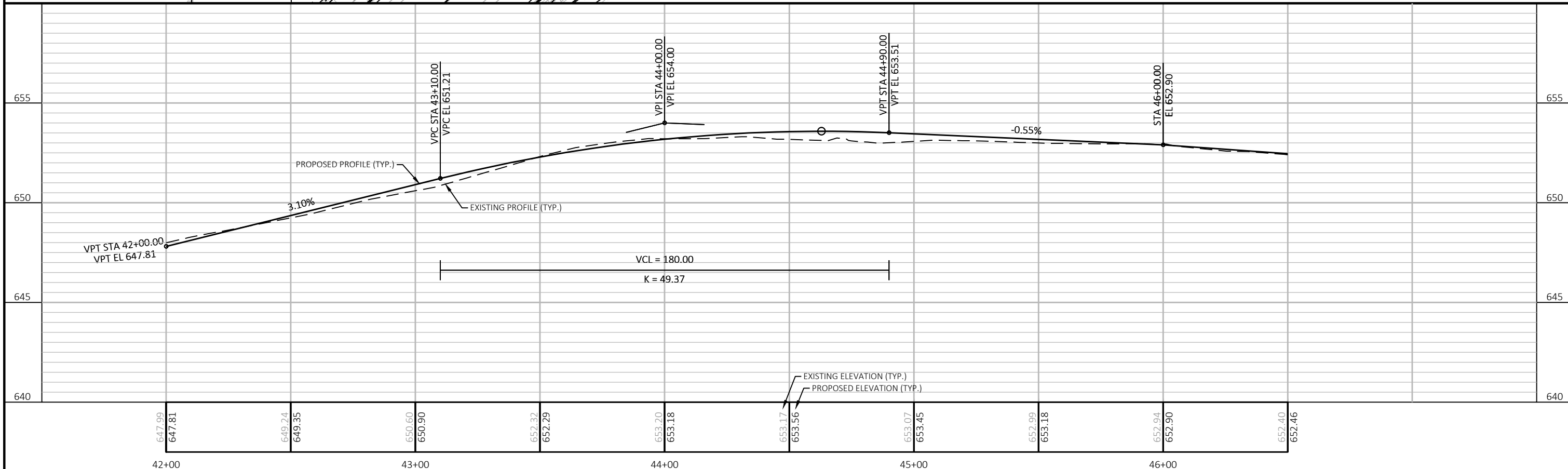
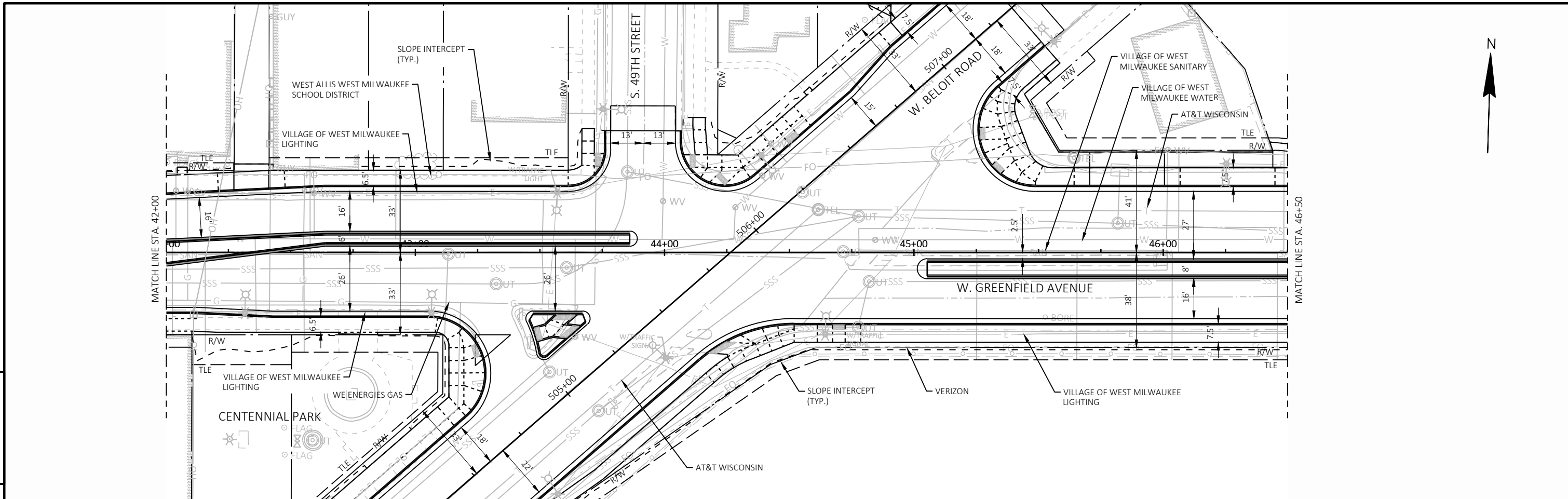

PROJECT NO: 2230-07-73	HWY: W. GREENFIELD AVENUE	COUNTY: MILWAUKEE	PLAN AND PROFILE	SHEET	E
------------------------	---------------------------	-------------------	------------------	-------	----------

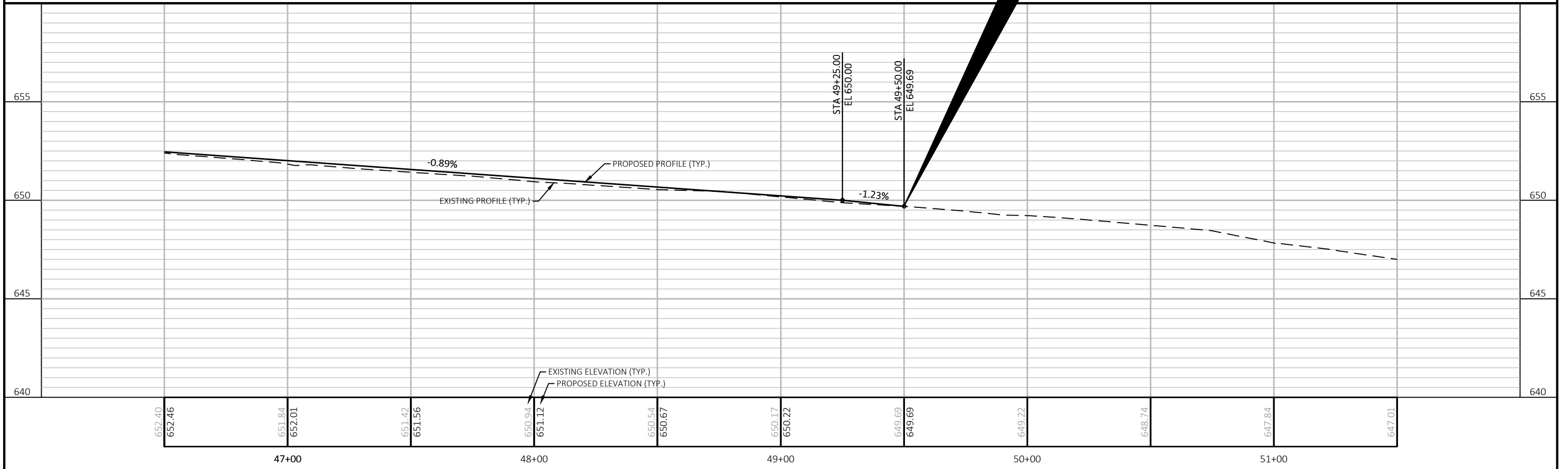
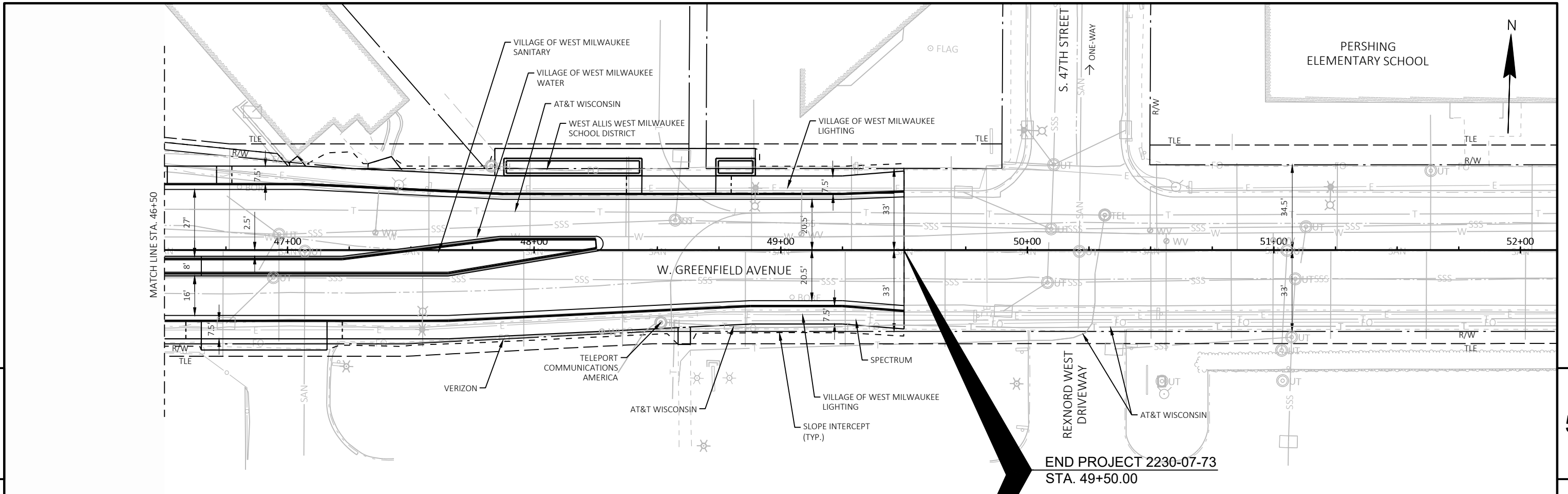

PROJECT NO: 2230-07-73	HWY: W. GREENFIELD AVENUE	COUNTY: MILWAUKEE	PLAN AND PROFILE	SHEET	E
------------------------	---------------------------	-------------------	------------------	-------	----------

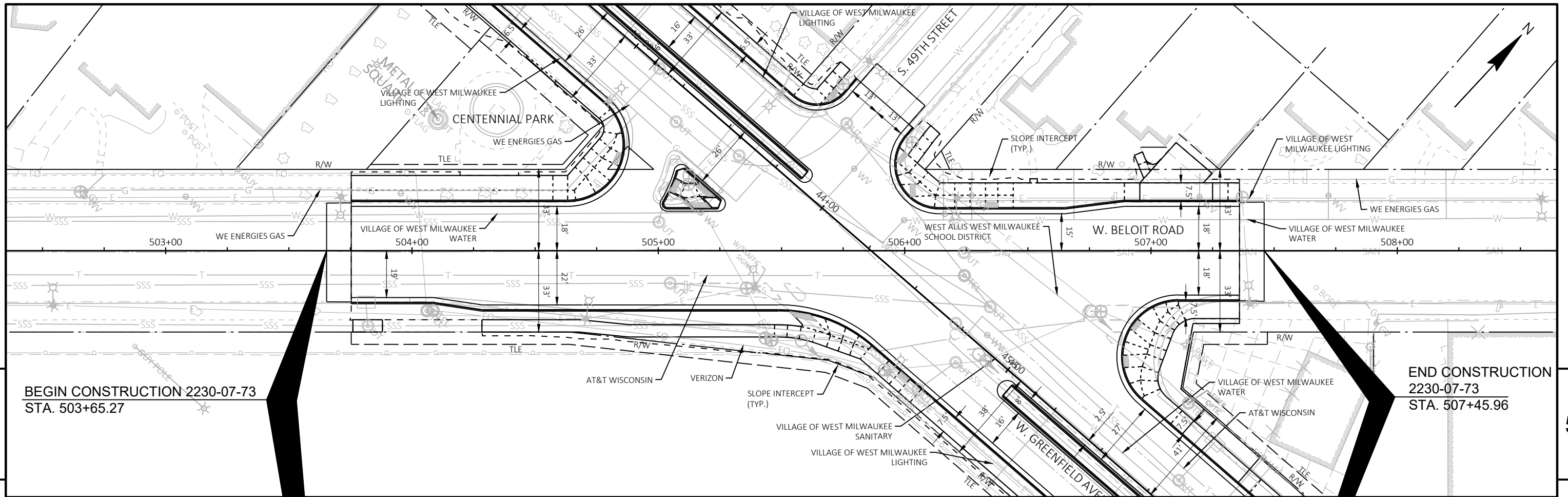

BEGIN CONSTRUCTION 2230-07-73
STA. 503+65.27

END CONSTRUCTION 2230-07-73
STA. 507+45.96

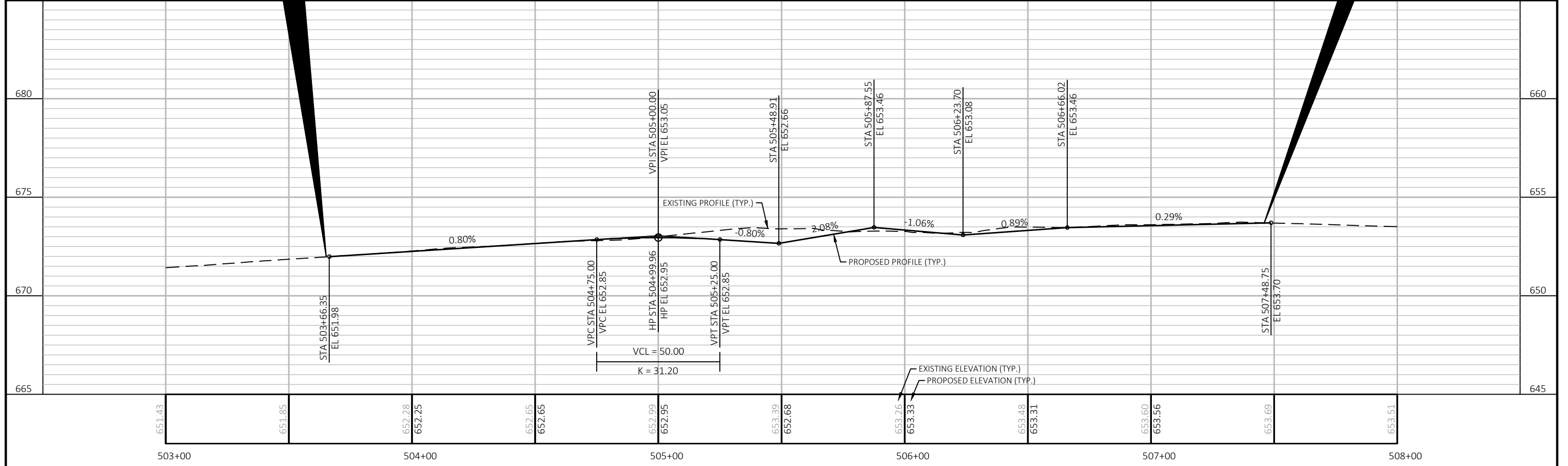

PROJECT NO: 2230-07-73	HWY: W. GREENFIELD AVENUE	COUNTY: MILWAUKEE	PLAN AND PROFILE: W BELOIT ROAD	SHEET	E
------------------------	---------------------------	-------------------	---------------------------------	-------	----------

Standard Detail Drawing List

08A05-19A	INLET COVERS TYPE A, H, A-S, H-S & Z
08A05-19C	INLET COVERS TYPE F, HM, HM-S, S, T, V, HM-GJ, & HM-GJ-S
08A05-19D	INLET COVER TYPE BW, MANHOLE COVERS, TYPE K, J, J-S, L & M
08A09-02	CATCH BASINS 2X3-FT AND 2.5X3-FT
08B09-03	MANHOLES 3-FT, 4-FT, 5-FT, 6-FT, 7-FT, 8-FT, 9-FT, 10-FT DIAMETER
08D01-23A	CONCRETE CURB & GUTTER
08D01-23B	CONCRETE CURB, TIES AND CURB AND GUTTER APPLICATIONS
08D05-20A	CURB RAMPS TYPES 1 AND 1-A
08D05-20B	CURB RAMPS TYPES 2 AND 3
08D05-20C	CURB RAMPS TYPES 4A AND 4A1
08D05-20D	CURB RAMPS TYPE 4B AND 4B1
08D05-20E	CURB RAMPS TYPES 5, 6, 7A, 7B & 8
08D05-20F	CURB RAMPS RADIAL DETECTABLE WARNING FIELD APPLICATIONS
08D05-20G	CURB RAMPS RECTANGULAR AND RADIAL DETECTABLE WARNING PLATES
08D16-11	CONCRETE GUTTER, CURB AND GUTTER AND PAVEMENT TIES
08D17-06	MANHOLES, MANHOLE & INLET COVERS
08E10-02	INLET PROTECTION TYPE A, B, C AND D
08E14-01	TRACKING PAD
09B02-10	CONDUIT
09B04-12	PULL BOX
09C02-09	CONCRETE BASES, TYPES 1, 2, 5, & 6
09C03-04	TRANSFORMER/PEDESTAL BASES
09C06-07	CONCRETE CONTROL CABINET BASE, TYPE 9, SPECIAL
09C11-10	CONCRETE BASE TYPE 10
09C14-03	CONCRETE CONTROL CABINET BASE, TYPE L
09C15-01	CONCRETE BASE TYPE 10 SPECIAL
09D01-05	CABINET SERVICE INSTALLATION (METER BREAKER PEDESTAL)
09D02-03	SIGNAL CONTROL CABINET
09D05-02	L30 LIGHTING CONTROL CABINET 240/480 VOLT
09E01-15B	POLE MOUNTINGS FOR TRAFFIC SIGNALS AND LIGHTING UNITS, TYPE 3 (HEAVY DUTY)
09E01-15D	POLE MOUNTINGS FOR LIGHTING UNITS, TYPE 5 (30 FEET)
09E01-15G	HARDWARE DETAILS FOR POLE MOUNTINGS
09E03-06	NON-FREEWAY LIGHTING UNIT POLE WIRING
09E06-05	TRAFFIC SIGNAL STANDARD POLY BRACKET MOUNTINGS (TYPICAL) 13 FT. OR 15 FT.
09E07-06	TRAFFIC SIGNAL STANDARD PEDESTRIAN AND FLASHER TYPICAL MOUNTING DETAILS
09E08-09E	TYPE 10 POLE 15' -30' MONOTUBE ARM
09E08-09F	TYPE 10 SPECIAL POLE 35' MONOTUBE ARM
09E08-09K	GENERAL NOTES, HARDWARE DETAILS FOR TYPE 9/10, 9/10 SPECIAL, 12 & 13 POLES W/MONOTUBE ARMS
11B02-02	CONCRETE MEDIUM NOSE
12A04-03	STRUCTURE IDENTIFICATION PLAQUES, RAMP GATES, SIGN BRIDGES & OVERHEAD SIGN SUPPORTS & TRAFFIC SIGNALS
13C01-19	CONCRETE PAVEMENT LONGITUDINAL JOINTS AND TIES
13C13-11	URBAN DOWELED CONCRETE PAVEMENT
13C18-08A	CONCRETE PAVEMENT JOINTING
13C18-08B	CONCRETE PAVEMENT STEEL REINFORCEMENT
13C18-08C	CONCRETE PAVEMENT JOINT TYPES
13C18-08D	CONCRETE PAVEMENT JOINTING AT UTILITY FIXTURES
13C18-08E	CONCRETE PAVEMENT JOINTING AND STEEL REINFORCEMENT IN ROUNDABOUTS
13C18-08F	CONCRETE PAVEMENT INTERSECTION BOXOUT FOR INTEGRAL CURB AND GUTTER
13C19-03	HMA LONGITUDINAL JOINTS
15C02-09A	BARRICADES AND SIGNS FOR MAINLINE CLOSURES
15C02-09B	BARRICADES AND SIGNS FOR VARIOUS CLOSURES
15C02-09C	DETOUR SIGNING FOR MAINLINE CLOSURES
15C03-05	BARRICADES AND SIGNS FOR SIDEROAD CLOSURES
15C05-05	TRAFFIC CONTROL, ADVANCE WARNING SIGNS 40 M. P. H. OR LESS
15C07-15A	PAVEMENT MARKING SYMBOLS
15C07-15B	PAVEMENT MARKING WORDS
15C07-15C	PAVEMENT MARKING ARROWS
15C07-15E	PAVEMENT MARKING FOR BIKE LANES
15C08-23A	PERMANENT LONGITUDINAL PAVEMENT MARKINGS
15C08-23D	PAVEMENT MARKING (TURN LANES)
15C11-10B	CHANNELIZING DEVICES DRUMS, CONES, BARRICADES AND VERTICAL PANELS
15C18-08A	MEDIAN ISLAND MARKING PAVEMENT MARKINGS
15C18-08B	MEDIAN ISLAND MARKING MEDIAN ISLAND NOSE
15C29-08A	BI-CYCLE LANE MARKING
15C33-04	STOP LINE AND CROSSWALK PAVEMENT MARKING
15D30-09A	TRAFFIC CONTROL, PEDESTRIAN ACCOMMODATION
15D30-09B	TRAFFIC CONTROL, PEDESTRIAN ACCOMMODATION

Standard Detail Drawing List

15D30-09C	TRAFFIC CONTROL, PEDESTRIAN ACCOMMODATION
15D30-09D	TRAFFIC CONTROL, PEDESTRIAN ACCOMMODATION
15D30-09E	TRAFFIC CONTROL, PEDESTRIAN ACCOMMODATION
15D30-09F	TRAFFIC CONTROL, PEDESTRIAN ACCOMMODATION
15D30-09G	TRAFFIC CONTROL, PEDESTRIAN ACCOMMODATION
15D30-09H	TRAFFIC CONTROL, PEDESTRIAN ACCOMMODATION
15D30-09I	TRAFFIC CONTROL, PEDESTRIAN ACCOMMODATION
15D30-09J	TRAFFIC CONTROL, PEDESTRIAN ACCOMMODATION
15D30-09K	TRAFFIC CONTROL, PEDESTRIAN ACCOMMODATION
15D30-09L	TRAFFIC CONTROL, PEDESTRIAN ACCOMMODATION
15D50-03B	TRAFFIC CONTROL, ADDED LANE CLOSURE WITH LANE SHIFT
16A01-07	LANDMARK REFERENCE MONUMENTS AND COVERS

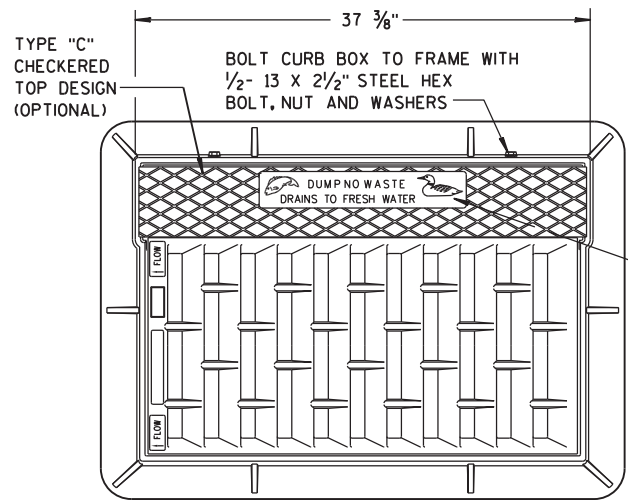

**NOTE:
GRATE IS REVERSIBLE.**

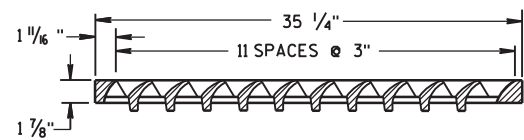
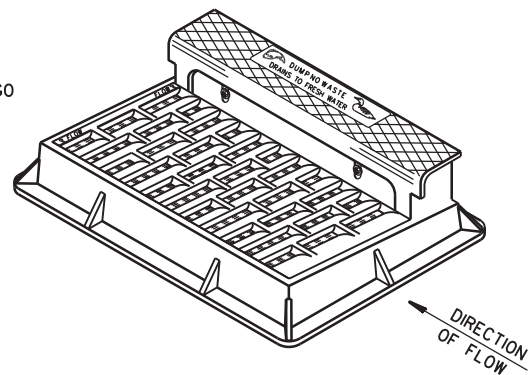

NOTE: CURB BOX HEIGHT ADJUSTABLE 6" TO 9"

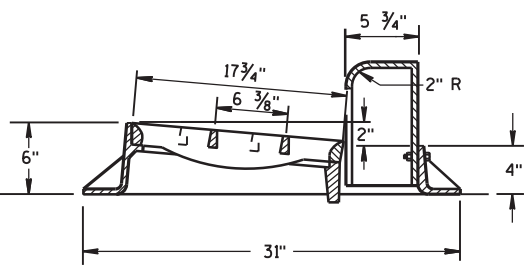
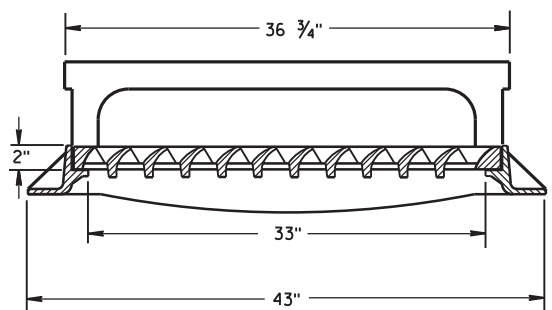
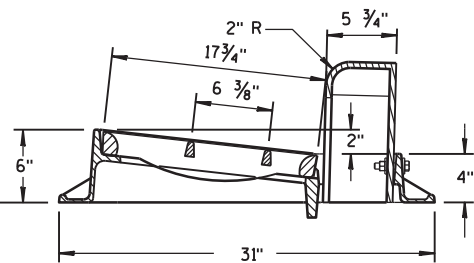
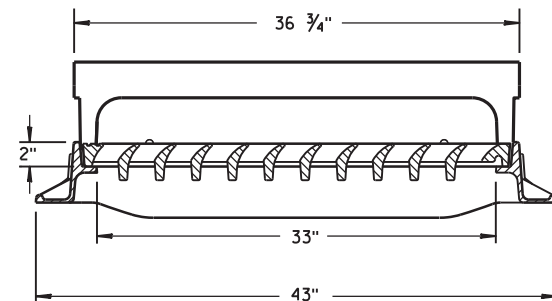

TYPE "H"

NOTE: EITHER CASTING IS ACCEPTABLE

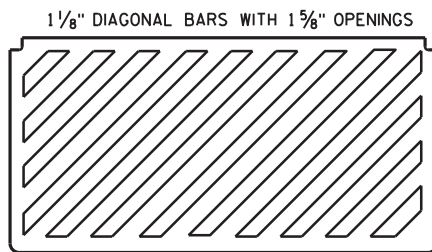

**SPECIAL GRATE FOR
TYPE "H" COVER**

(MEASURES 35 1/4" X 17 3/4" X 2")
(NOTED AS TYPE H-S ON DRAINAGE TABLE)

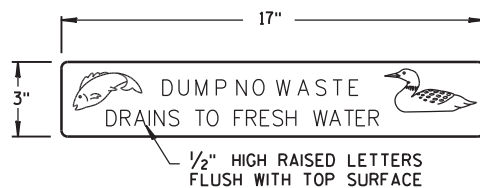

LOGO DETAIL

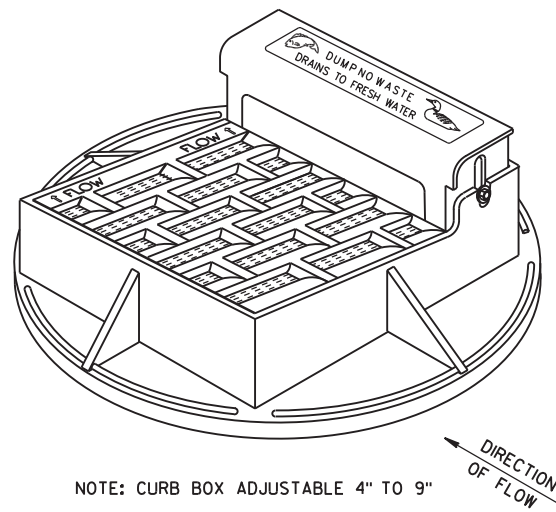

**NOTE:
GRATE IS REVERSIBLE.**

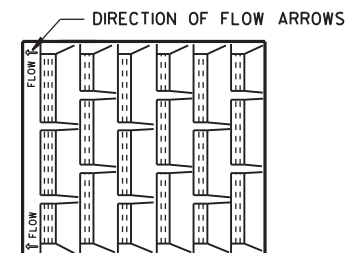

**SPECIAL GRATE FOR
TYPE "A" COVER**
(MEASURES 19 3/4" X 17" X 1 1/8")
(NOTED AS TYPE A-S ON DRAINAGE TABLE)

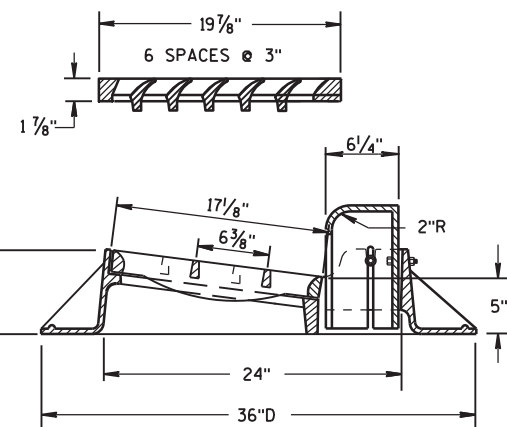
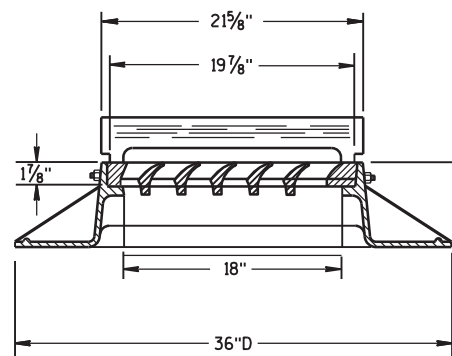

TYPE "A"

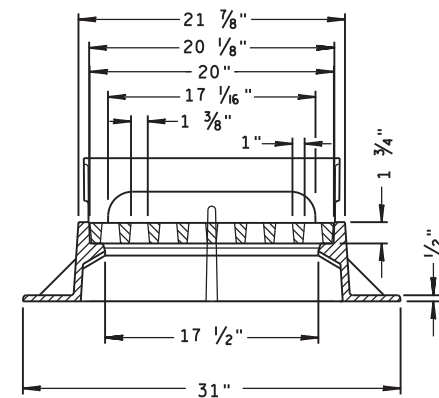
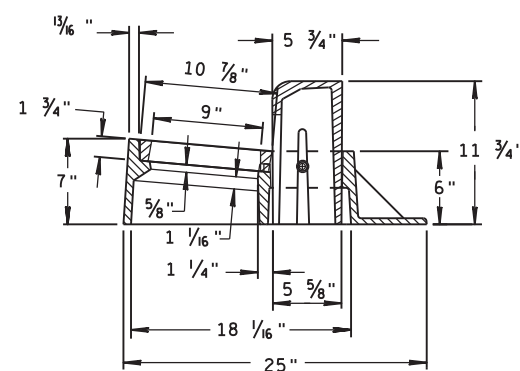

TYPE "Z"

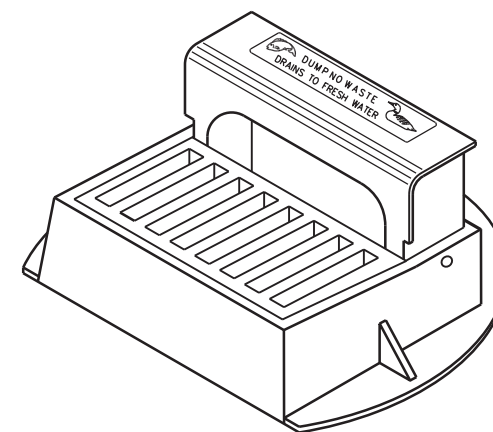

**INLET COVERS
TYPE A, H, A-S, H-S & Z**

STATE OF WISCONSIN
DEPARTMENT OF TRANSPORTATION

APPROVED
DATE: 11-27-13
DATE: /S/ Jerry H. Zogg
ROADWAY STANDARDS DEVELOPMENT
ENGINEER
FHWA

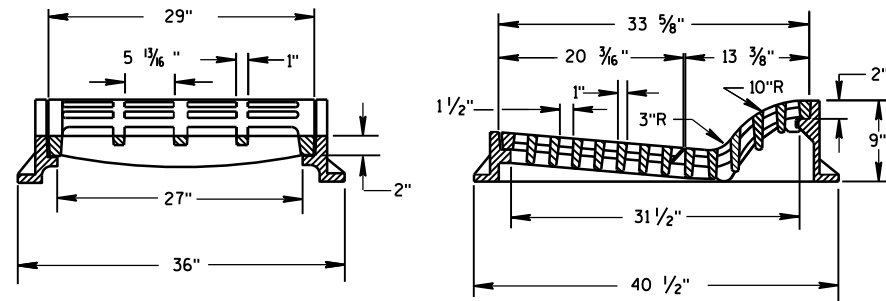
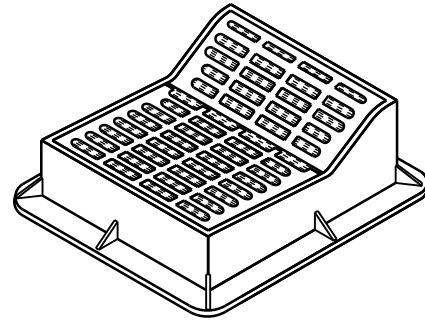

TYPE "F"

USE WITH TYPES A & D CONCRETE CURB & GUTTER, 36 INCH.

GENERAL NOTES

DETAILS OF CONSTRUCTION, MATERIALS AND WORKMANSHIP NOT SHOWN ON THIS DRAWING SHALL CONFORM TO THE PERTINENT REQUIREMENTS OF THE STANDARD SPECIFICATIONS AND THE APPLICABLE SPECIAL PROVISIONS.

DETAIL DRAWINGS FOR PROPOSED ALTERNATE DESIGNS FOR INLET COVERS SHALL BE SUBMITTED TO THE ENGINEER FOR APPROVAL PROVIDING THAT SUCH ALTERNATE DESIGNS MAKE PROVISION FOR EQUIVALENT CAPACITY AND STRENGTH.

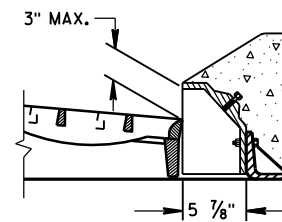

ALTERNATIVE CURB BOX FOR TYPE "HM" COVER

USE WITH TYPES G & J CONCRETE CURB & GUTTER, 30 INCH NOTED AS TYPE HM-GJ ON DRAINAGE TABLE

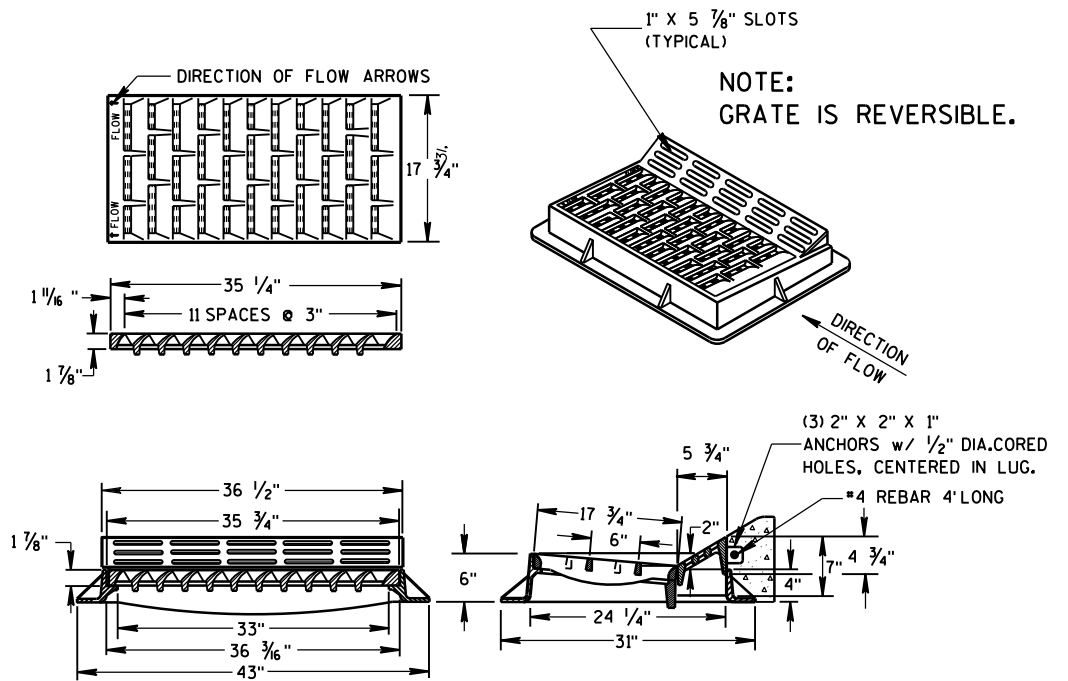

TYPE "HM"

USE WITH TYPES A & D CONCRETE CURB & GUTTER, 36 INCH.

NOTE: SPECIAL GRATE FOR THE TYPE "H" COVER MAY ALSO BE USED FOR THE TYPE "HM" COVER NOTED AS TYPE HM-S ON DRAINAGE TABLE

NOTE: SPECIAL GRATE FOR THE TYPE "H" COVER MAY ALSO BE USED FOR THE TYPE "HM-GJ" COVER NOTED AS TYPE HM-GJ-S ON DRAINAGE TABLE

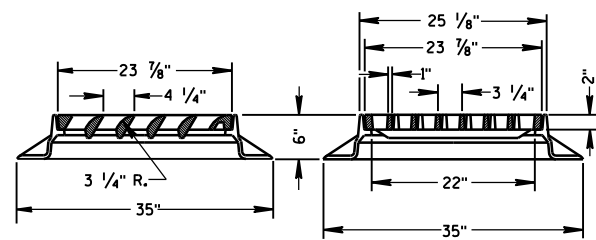
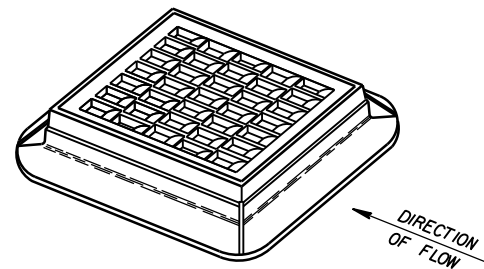

TYPE "S"

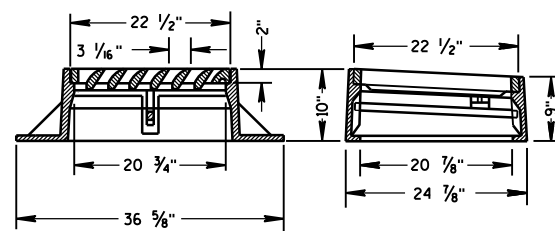
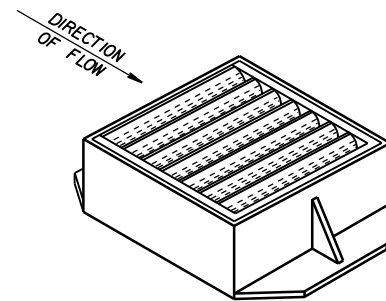

TYPE "V"

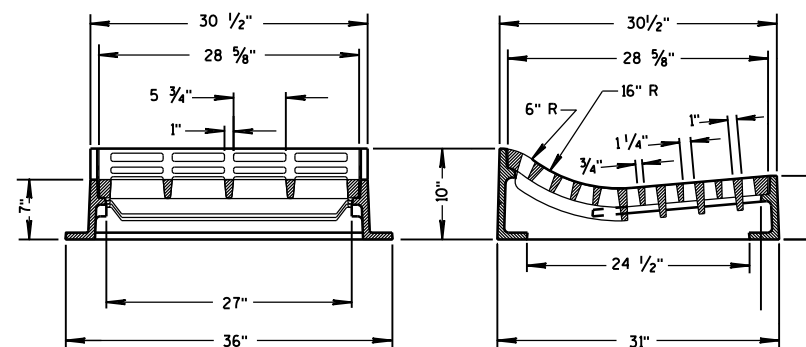

TYPE "T"

USE WITH TYPES R & T CONCRETE CURB & GUTTER, 36 INCH.

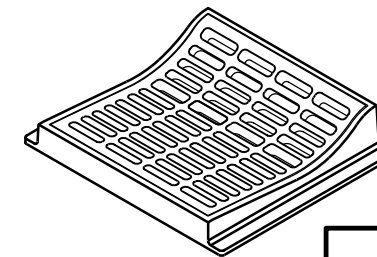

INLET COVERS
TYPE F, HM, HM-S, S, T, V,
HM-GJ, & HM-GJ-S

STATE OF WISCONSIN
DEPARTMENT OF TRANSPORTATION

APPROVED
11/27/2013 DATE /s/ Jerry H. Zogg
ROADWAY STANDARDS DEVELOPMENT ENGINEER
FHWA

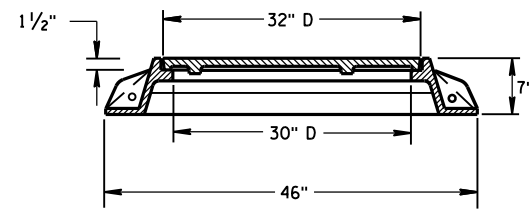
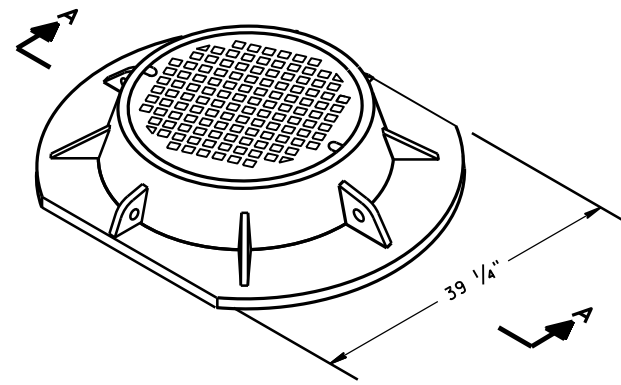

SECTION A-A
TYPE "K"

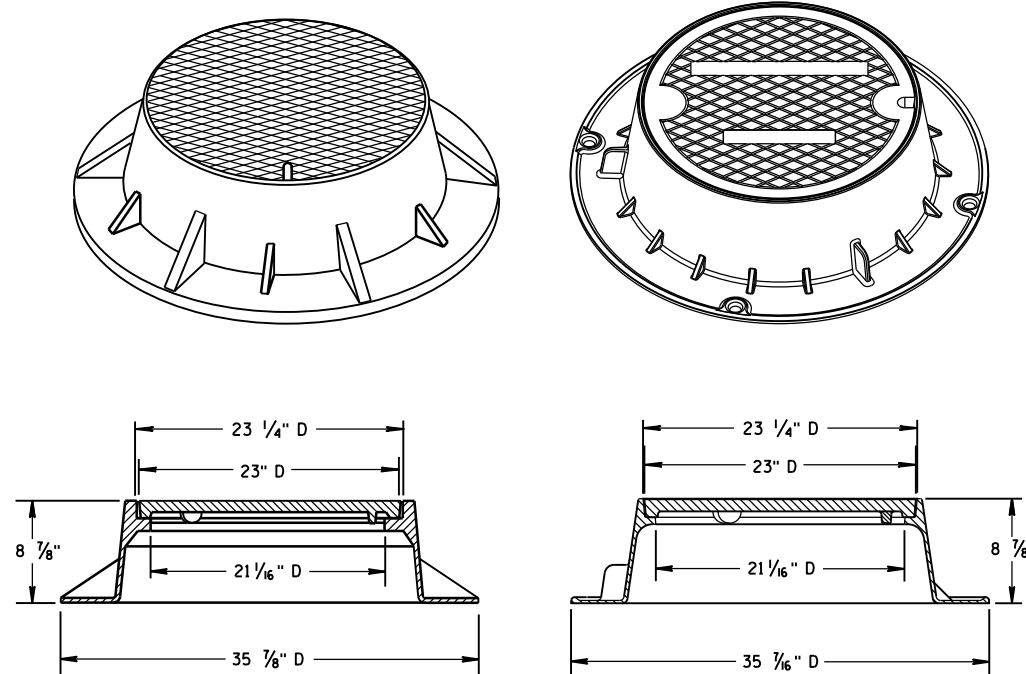

TYPE "J"

NOTE: EITHER CASTING IS ACCEPTABLE

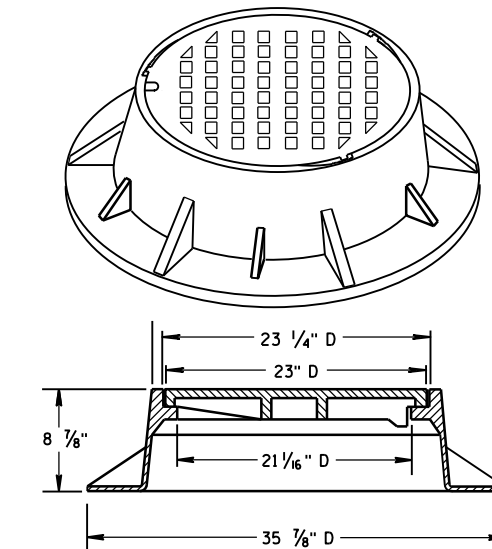
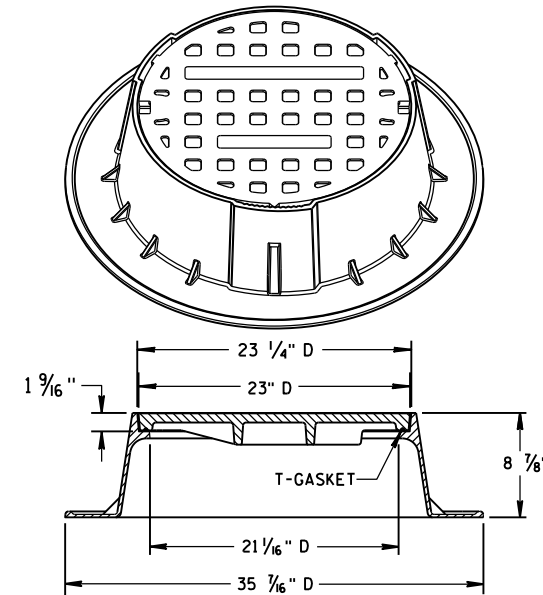

TYPE "J" SPECIAL

TYPE "B" NON-ROCKING SELF-SEAL LID

(NOTED AS TYPE J-S ON THE DRAINAGE TABLE)

NOTE: EITHER CASTING IS ACCEPTABLE

6

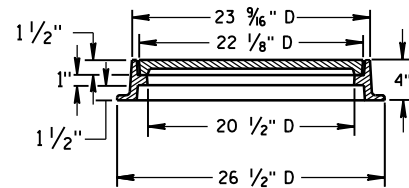
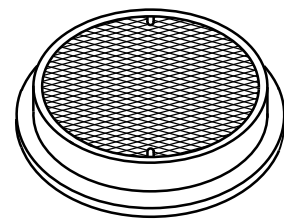

TYPE "L"

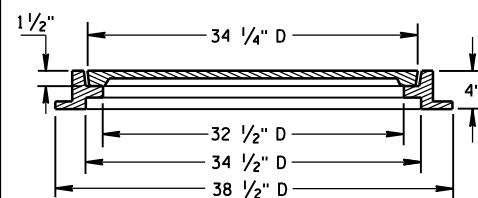
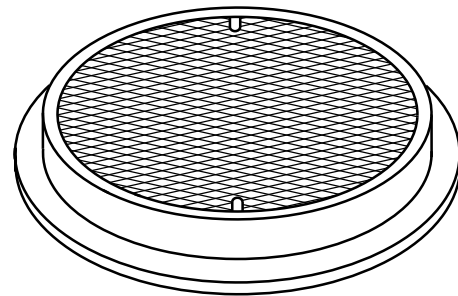

TYPE "M"

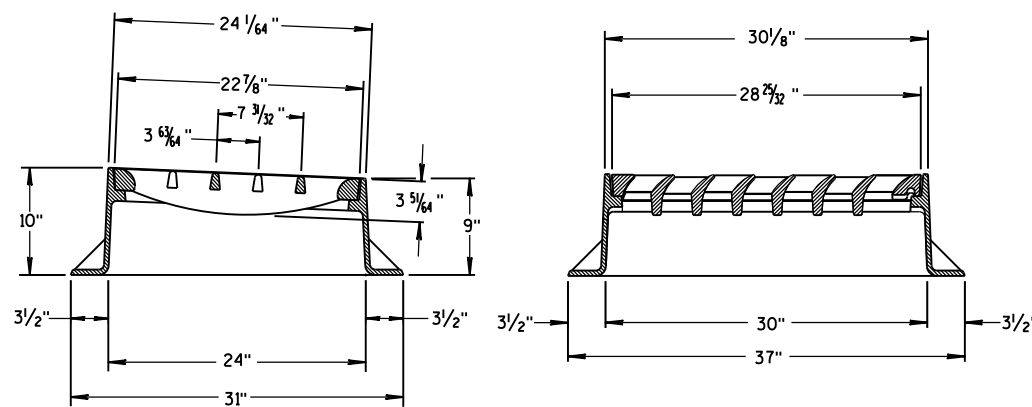
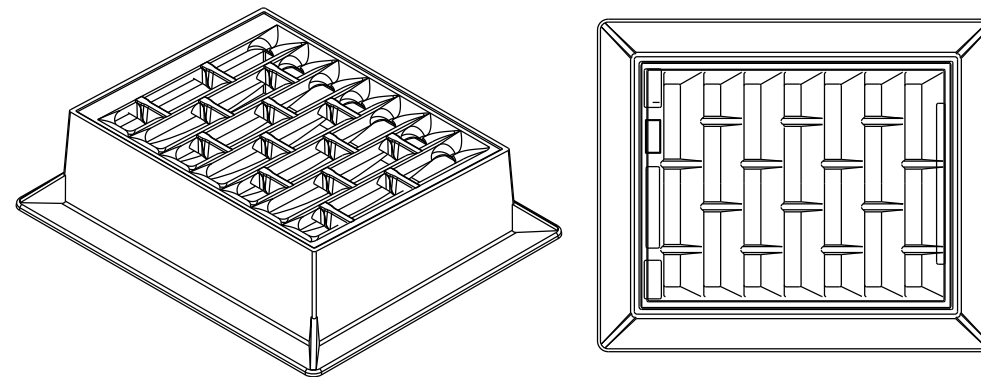

INLET COVER TYPE "BW"

6

GENERAL NOTES

DETAILS OF CONSTRUCTION, MATERIALS AND WORKMANSHIP NOT SHOWN ON THIS DRAWING SHALL CONFORM TO THE PERTINENT REQUIREMENTS OF THE STANDARD SPECIFICATIONS AND THE APPLICABLE SPECIAL PROVISIONS.

DETAIL DRAWINGS FOR PROPOSED ALTERNATE DESIGNS FOR MANHOLE COVERS SHALL BE SUBMITTED TO THE ENGINEER FOR APPROVAL PROVIDING THAT SUCH ALTERNATE DESIGNS MAKE PROVISION FOR EQUIVALENT CAPACITY AND STRENGTH.

ROUND FRAMES AND COVERS SHALL HAVE CONTINUOUSLY MACHINED BEARING SURFACES TO PREVENT ROCKING AND RATTLING.

S.D.D. 8 A 5-19d

S.D.D. 8 A 5-19d

INLET COVER TYPE BW
MANHOLE COVERS, TYPE K,
J, J-S, L & M

STATE OF WISCONSIN
DEPARTMENT OF TRANSPORTATION

APPROVED
11/27/2013 DATE /S/ Jerry H. Zogg
ROADWAY STANDARDS DEVELOPMENT
ENGINEER
FHWA

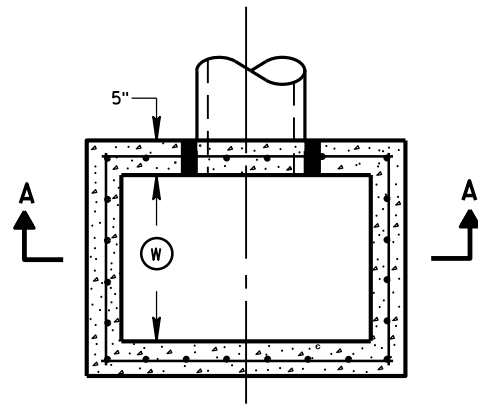

PLAN VIEW

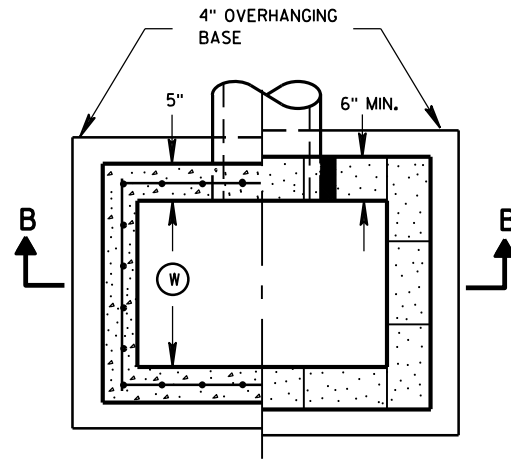

PLAN VIEW

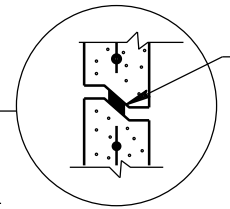

RISER JOINTS TO BE SEALED WITH A BUTYL RUBBER SEAL PER SEALANT MANUFACTURERS RECOMMENDATIONS CONFORMING TO ASTM C 990 (TYP)

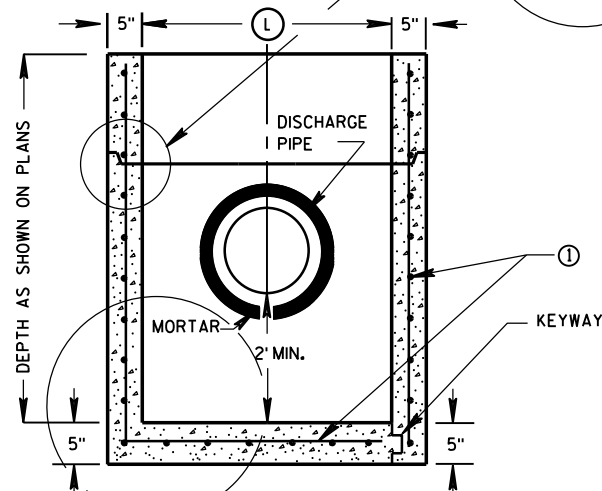

PRECAST REINFORCED CONCRETE WITH MONOLITHIC BASE

SECTION A-A

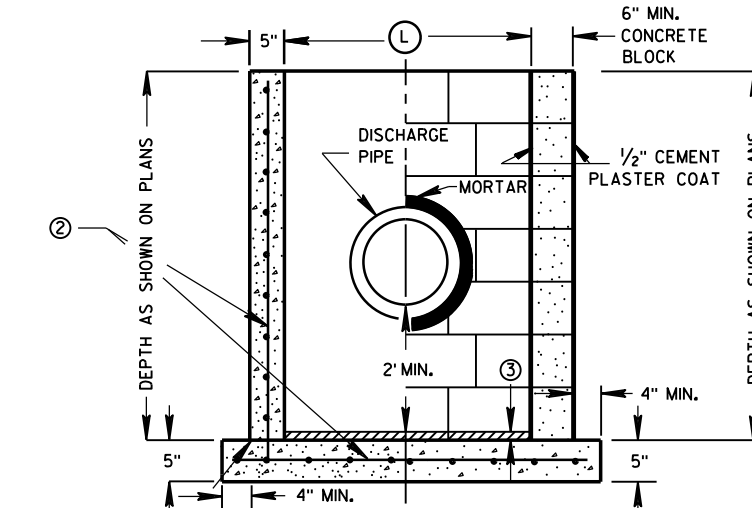

CAST-IN-PLACE REINFORCED CONCRETE CONCRETE BLOCK ON CAST-IN-PLACE WITH PRECAST REINFORCED CONCRETE BASE ①

SECTION B-B

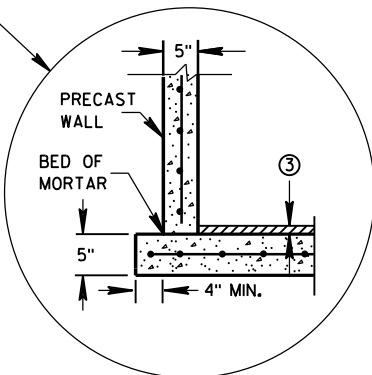

SEPARATE PRECAST REINFORCED CONCRETE BASE OPTION

GENERAL NOTES

DETAILS OF CONSTRUCTION, MATERIALS AND WORKMANSHIP NOT SHOWN ON THIS DRAWING SHALL CONFORM TO THE PERTINENT REQUIREMENTS OF THE STANDARD SPECIFICATIONS AND THE APPLICABLE SPECIAL PROVISIONS.

UNLESS OTHERWISE AUTHORIZED IN WRITING BY THE ENGINEER, THE CONTRACTOR SHALL NOT ORDER AND DELIVER PRECAST CATCH BASIN UNITS REQUIRED FOR THE PROJECT UNTIL A LIST OF SIZES IS FURNISHED BY THE ENGINEER.

DETAILED DRAWINGS FOR PROPOSED ALTERNATE DESIGNS FOR UNDERGROUND DRAINAGE STRUCTURES SHALL BE SUBMITTED TO THE ENGINEER FOR APPROVAL PROVIDING THAT SUCH ALTERNATE DESIGNS MAKE PROVISION FOR EQUIVALENT CAPACITY AND STRENGTH.

ALL PRECAST CATCH BASIN UNITS SHALL CONFORM TO THE PERTINENT REQUIREMENTS OF ASTM C 913.

ALL DRAINAGE STRUCTURES ARE DESIGNATED ON THE PLANS AS "MANHOLES 3X3-L", "CATCH BASINS 4-B", "INLETS 2X3-H", ETC. THE FIRST NUMBERS DESIGNATES THE SIZE OF THE STRUCTURE, AND THE FOLLOWING LETTER DESIGNATES THE TYPE OF COVER TO BE USED TO COMPRISE THE COMPLETE UNIT.

BASES SHALL BE PLACED ON A BED OF MATERIAL AT LEAST 6 INCHES IN DEPTH, WHICH MEETS THE REQUIREMENTS OF FOUNDATION BACKFILL. THIS BEDDING SHALL BE COMPACTED AND PROVIDE UNIFORM SUPPORT FOR THE ENTIRE AREA OF THE BASE.

ALL BAR STEEL REINFORCEMENT SHALL BE EMBEDDED 2 INCHES CLEAR UNLESS OTHERWISE SHOWN OR NOTED.

PRECAST REINFORCED RISERS SHALL HAVE A TONGUE AND GROOVE JOINT WITH TONGUE UP OR DOWN.

4" OVERHANGING BASES ARE REQUIRED FOR CAST-IN-PLACE REINFORCED CONCRETE AND CONCRETE BLOCK INSTALLATIONS. 4" OVERHANG IS REQUIRED WHEN SEPARATE PRECAST BASE IS PROVIDED. OVERHANG IS NOT REQUIRED ON PRECAST STRUCTURES WITH AN INTEGRAL OR MONOLITHIC BASE.

MAXIMUM INSIDE PIPE DIAMETER DETERMINED BY 3" CLEARANCE ON EACH SIDE OF THE OUTSIDE WALL OF THE PIPE. SEE DETAIL "A". ASSUMES PIPE ENTERS PERPENDICULAR TO THE STRUCTURE.

- ① FOR PRECAST CATCH BASINS PROVIDE REINFORCING STEEL IN ACCORDANCE TO ASTM C 913.
- ② CONTRACTOR TO PROVIDE DRAWING(S) STAMPED BY A PROFESSIONAL ENGINEER FOR STEEL REINFORCING DESIGN FOR CAST-IN-PLACE STRUCTURES.
- ③ 1" CONCRETE KEY POURED AFTER INSTALLATION. 2" SUMP MEASURED FROM TOP OF KEY.

CATCH BASIN COVER MATRIX

CATCH BASIN SIZE	INLET COVER TYPE		F	ALL H'S
	WIDTH (W) (FT)	LENGTH (L) (FT)		
2X3-FT	2	3		X
2.5X3-FT	2.5	3	X	

PIPE MATRIX

CATCH BASIN SIZE	MAXIMUM INSIDE PIPE DIAMETER FOR TWO PIPES	
	WIDTH (IN)	LENGTH (IN)
2X3-FT	12	24
2.5X3-FT	18	24

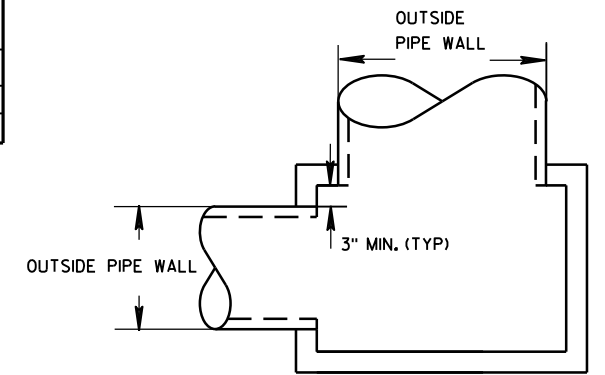

DETAIL "A"

CATCH BASINS 2X3-FT AND 2.5X3-FT

STATE OF WISCONSIN DEPARTMENT OF TRANSPORTATION

APPROVED
 Sep 2016 /S/ Rodney Taylor
 DATE ROADWAY STANDARDS DEVELOPMENT
 FHWA UNIT SUPERVISOR

CATCH BASINS 2X3-FT AND 2.5X3-FT

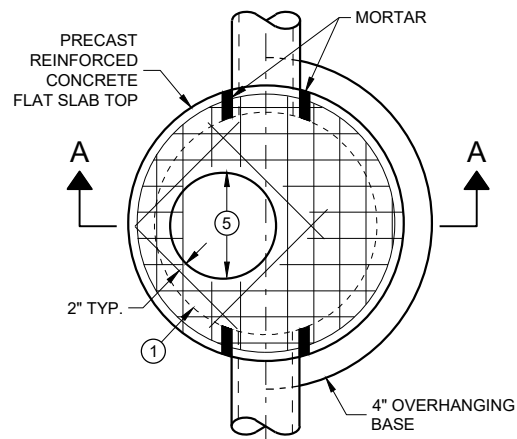

**PLAN VIEW
CIRCULAR OPENING**

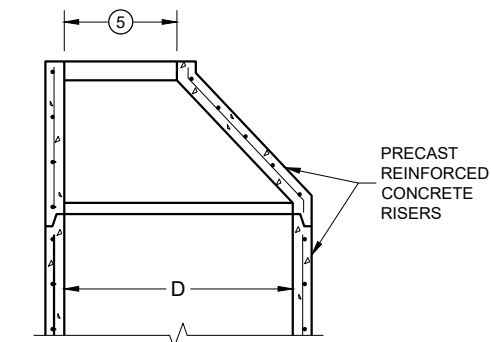

**OPTIONAL PRECAST
REINFORCED CONCRETE
ECCENTRIC TOP**

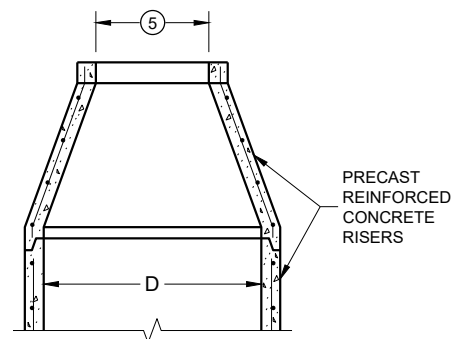

**OPTIONAL PRECAST
REINFORCED CONCRETE
CONCENTRIC TOP**

MANHOLE COVER OPENING MATRIX

MANHOLE COVER TYPE OPENING SIZE (FT.)	C	ALL J'S	K	L	M
2 DIA.	X	X		X	
3 DIA.			X		X

PIPE MATRIX

MANHOLE SIZE (DIA.)	MAXIMUM INSIDE PIPE DIAMETER FOR TWO PIPES		MINIMUM WALL THICKNESS (IN)	MINIMUM PRECAST FLAT SLAB TOP AND BASE THICKNESS
	180° SEPARATION (IN)	90° SEPARATION (IN)		
3-FT	15	12	4	6
4-FT	24	18	4	6
5-FT	36	24	5	8
6-FT	42	36	6	8
7-FT	48	36/42*	7	8
8-FT	60	42	8	8
9-FT	66	54	9	10
10-FT	72	60	10	10

*A 36" PIPE AND A 42" PIPE CAN BE PLACED WITHIN 90 DEGREES. SEE MINIMUM HORIZONTAL PIPE SEPARATION DETAIL.

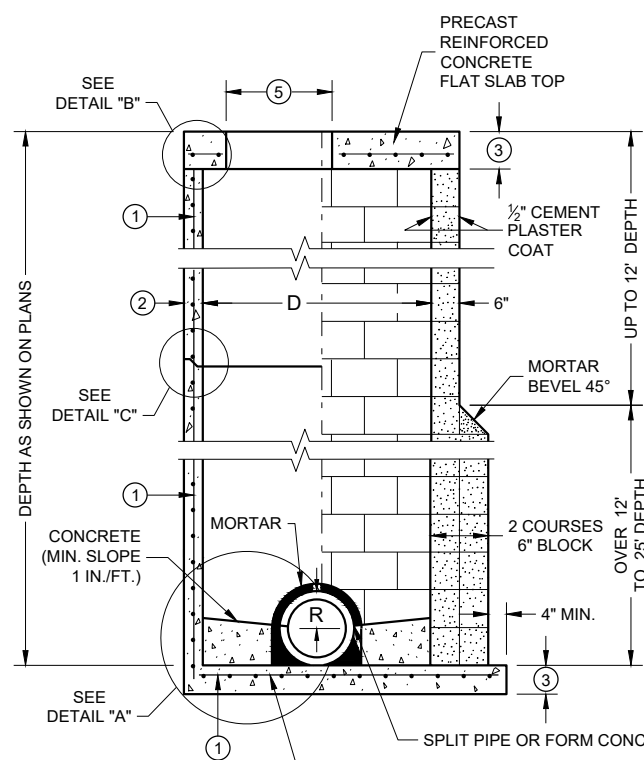

SECTION A - A

PRECAST REINFORCED CONCRETE WITH MONOLITHIC BASE

CONCRETE BLOCK WITH CAST IN PLACE OR PRECAST REINFORCED CONCRETE BASE ①

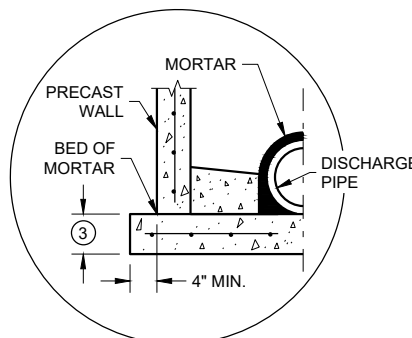

SEPARATE PRECAST REINFORCED CONCRETE BASE OPTION

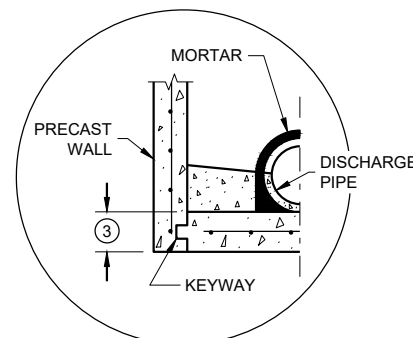

PRECAST REINFORCED CONCRETE WITH INTEGRAL BASE OPTION

DETAIL "A"

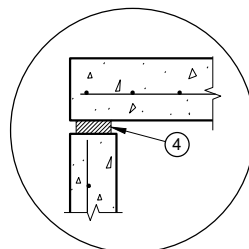

TOP WITH PLAIN END JOINT

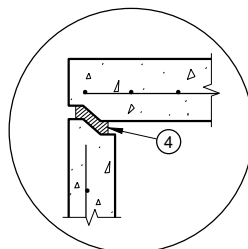

TOP WITH TONGUE AND GROOVE JOINT

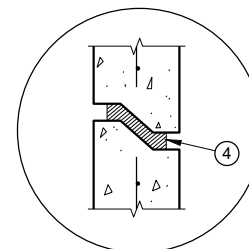

RISER WITH TONGUE AND GROOVE JOINT

DETAIL "B"

DETAIL "C"

MANHOLES 3-FT, 4-FT, 5-FT, 6-FT, 7-FT, 8-FT, 9-FT AND 10-FT DIAMETER

GENERAL NOTES

DETAILS OF CONSTRUCTION, MATERIALS AND WORKMANSHIP NOT SHOWN ON THIS DRAWING SHALL CONFORM TO THE PERTINENT REQUIREMENTS OF THE STANDARD SPECIFICATIONS AND THE APPLICABLE SPECIAL PROVISIONS.

UNLESS OTHERWISE AUTHORIZED IN WRITING BY THE ENGINEER, THE CONTRACTOR SHALL NOT ORDER AND DELIVER PRECAST MANHOLE UNITS REQUIRED FOR THE PROJECT UNTIL A LIST OF SIZES IS FURNISHED BY THE ENGINEER.

DETAILED DRAWINGS FOR PROPOSED ALTERNATE DESIGNS FOR UNDERGROUND DRAINAGE STRUCTURES SHALL BE SUBMITTED TO THE ENGINEER FOR APPROVAL PROVIDING THAT SUCH ALTERNATE DESIGNS MAKE PROVISION FOR EQUIVALENT CAPACITY AND STRENGTH.

ALL DRAINAGE STRUCTURES ARE DESIGNATED ON THE PLANS AS "MANHOLES 3X3-L", "CATCH BASINS 4-B", "INLETS 2X3-H", ETC. THE FIRST NUMBERS DESIGNATE THE SIZE OF THE STRUCTURE, AND THE FOLLOWING LETTER DESIGNATES THE TYPE OF COVER TO BE USED TO COMPRISE THE COMPLETE UNIT.

BASES SHALL BE PLACED ON A BED OF MATERIAL AT LEAST 6 INCHES IN DEPTH, WHICH MEETS THE REQUIREMENTS OF FOUNDATION BACKFILL. THIS BEDDING SHALL BE COMPACTED AND PROVIDE UNIFORM SUPPORT FOR THE ENTIRE AREA OF THE BASE.

PRECAST REINFORCED CONCRETE CONE TOPS (ECCENTRIC OR CONCENTRIC) OR PRECAST REINFORCED CONCRETE FLAT SLAB TOPS MAY BE USED ON CONCRETE BLOCK STRUCTURES.

ECCENTRIC CONE TOPS MAY BE USED ON ALL STRUCTURES. CONCENTRIC CONE TOPS SHALL BE USED ONLY ON STRUCTURES 5 FEET OR LESS IN DEPTH UNLESS OTHERWISE DIRECTED BY THE ENGINEER.

STEPS MEETING AASHTO M199 AND THE FOLLOWING REQUIREMENTS SHALL BE INSTALLED IN ALL STRUCTURES OVER 5 FEET IN DEPTH: 16 INCH C-C MAXIMUM SPACING; PROJECT A MINIMUM CLEAR DISTANCE OF 4 INCHES FROM THE WALL AT THE POINT OF EMBEDMENT; MINIMUM LENGTH OF 10 INCHES; MINIMUM WALL EMBEDMENT OF 3 INCHES. FERROUS METAL STEPS NOT PAINTED OR TREATED TO RESIST CORROSION SHALL HAVE A MINIMUM CROSS SECTIONAL DIMENSION OF 1 INCH.

STEPS OF APPROVED POLYPROPYLENE PLASTIC COATED REINFORCEMENT BAR ARE ACCEPTABLE. REINFORCING BAR MUST BE A MINIMUM OF 1/2 INCH AND MEET THE REQUIREMENTS OF ASTM A615.

CERTIFICATION SHALL BE PROVIDED THAT INSTALLED STEPS WHEN TESTED IN ACCORDANCE WITH SECTION 10 OF AASHTO T280 CAN WITHSTAND A VERTICAL LOAD OF 800 LBS. AND A HORIZONTAL LOAD OF 400 LBS.

ALL BAR STEEL REINFORCEMENT SHALL BE EMBEDDED 2 INCHES CLEAR UNLESS OTHERWISE SHOWN OR NOTED.

ALL PRECAST MANHOLE UNITS SHALL CONFORM TO THE PERTINENT REQUIREMENTS OF AASHTO DESIGNATION M199.

PRECAST REINFORCED RISERS SHALL HAVE A TONGUE AND GROOVE JOINT WITH TONGUE UP OR DOWN.

CONCRETE BLOCK WILL NOT BE PERMITTED FOR STRUCTURES GREATER THAN 4 FEET IN DIAMETER.

4" OVERHANGING BASES ARE REQUIRED FOR ALL CONCRETE BLOCK INSTALLATIONS. 4" OVERHANG IS REQUIRED WHEN SEPARATE PRECAST BASE IS PROVIDED. OVERHANG IS NOT REQUIRED ON PRECAST STRUCTURES WITH AN INTEGRAL OR MONOLITHIC BASE.

FOR ADDITIONAL CONFIGURATIONS, MAINTAIN A MINIMUM OF 12 INCHES AS MEASURED FROM THE INSIDE OF THE STRUCTURE WALL BETWEEN THE OUTSIDE PIPE WALLS OF ADJACENT PIPES. SEE DETAIL "D".

- ① FOR PRECAST MANHOLES PROVIDE REINFORCING STEEL IN ACCORDANCE TO AASHTO M199.
- ② SEE PIPE MATRIX TABLE FOR MINIMUM WALL THICKNESS FOR PRECAST MANHOLES
- ③ SEE PIPE MATRIX TABLE FOR MINIMUM THICKNESS OF PRECAST FLAT SLAB TOPS AND BASES.
- ④ JOINTS TO BE SEALED WITH A BUTYL RUBBER SEAL PER SEALANT MANUFACTURERS RECOMMENDATIONS CONFORMING TO ASTM C 990 (TYP.).
- ⑤ SEE MANHOLE COVER OPENING MATRIX.

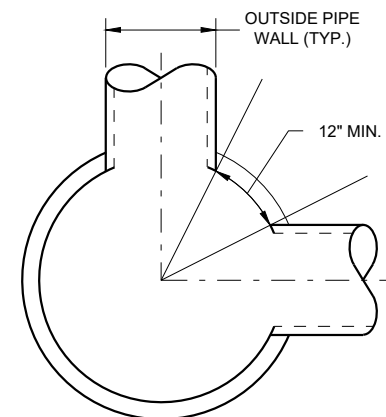

MINIMUM HORIZONTAL PIPE SEPARATION

**MANHOLES, 3-FT, 4-FT
5-FT, 6-FT, 7-FT, 8-FT, 9-FT
AND 10-FT DIAMETER**

STATE OF WISCONSIN
DEPARTMENT OF TRANSPORTATION

APPROVED
November 2021 /S/ Rodney Taylor
DATE ROADWAY STANDARDS DEVELOPMENT
ENGINEER
FHWA

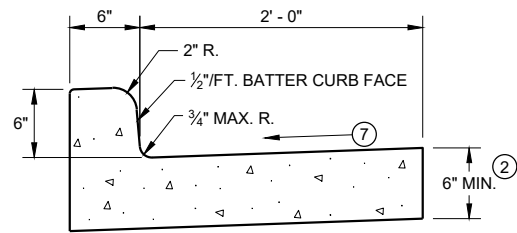

TYPES A^① & D

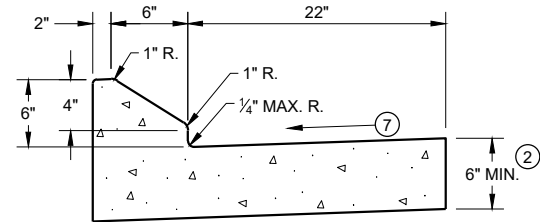

6" SLOPED CURB TYPES G^① & J

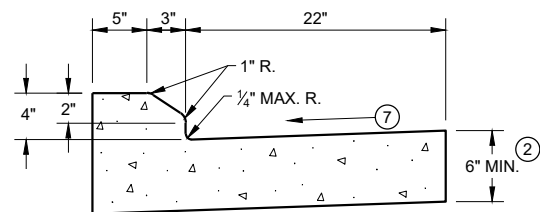

4" SLOPED CURB TYPES G^① & J

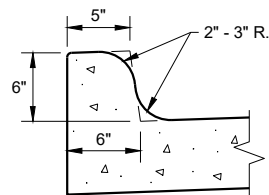

TYPES K^① & L
(OPTIONAL CURB SHAPE)

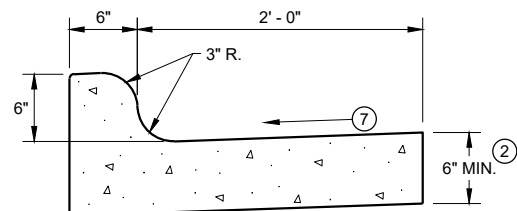

TYPES K^① & L
CONCRETE CURB AND GUTTER 30"

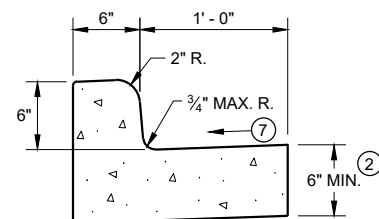

TYPES A^① & D
CONCRETE CURB AND GUTTER 18"

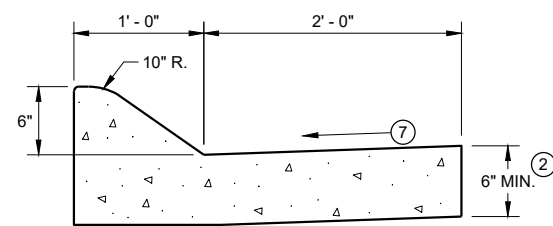

6" SLOPED CURB TYPES A^① & D

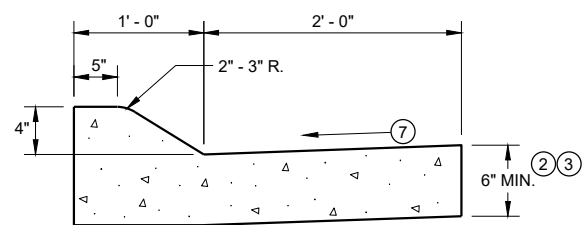

4" SLOPED CURB TYPES A^① & D
CONCRETE CURB AND GUTTER 36"

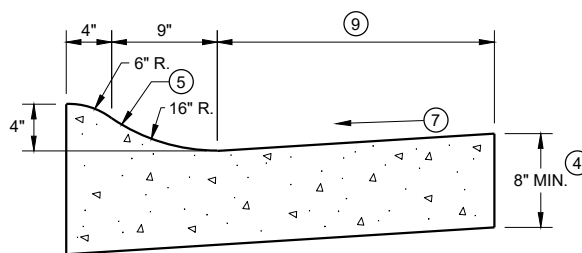

4" SLOPED CURB TYPES R^① & T

TBT & TBTT	X
30"	22"
36"	28"

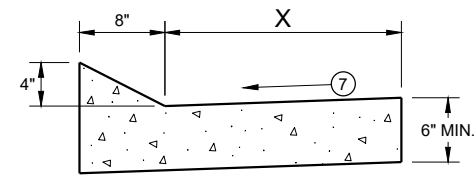

TYPES TBT & TBTT^①
CONCRETE CURB AND GUTTER

PAVEMENT THICKNESS AND MAXIMUM CONCRETE PANEL WIDTH TABLE

PAVEMENT THICKNESS	MAXIMUM PANEL WIDTH
LESS THAN 10"	12'
10" & ABOVE	15'

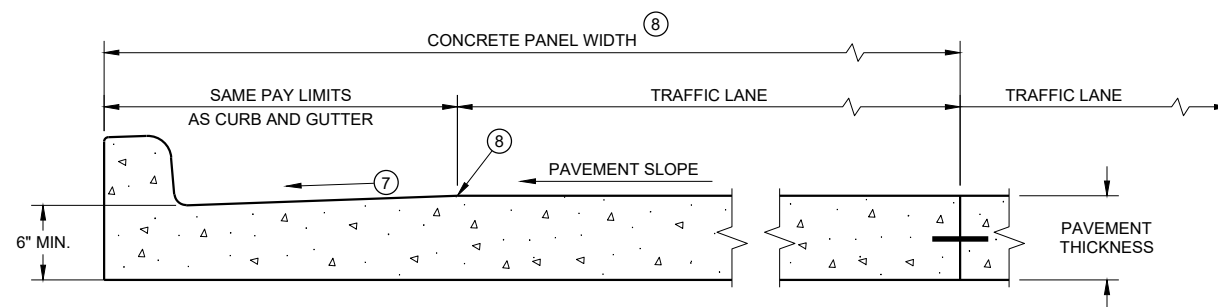

PARTIAL SECTION OF PAVEMENT* WITH INTEGRAL CURB AND GUTTER

* BIKE LANE IS NOT SHOWN

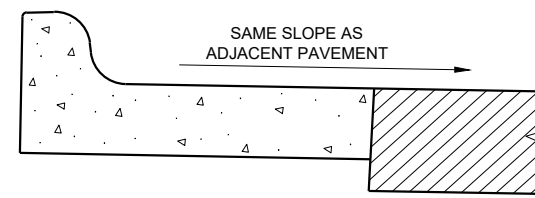

REVERSE SLOPE GUTTER^⑥
(TYPICAL FOR ALL CURB & GUTTER TYPES)

GENERAL NOTES

DETAILS OF CONSTRUCTION AND WORKMANSHIP NOT SHOWN ON THIS DRAWING SHALL CONFORM TO THE PERTINENT REQUIREMENTS OF THE CONTRACT.

PAVEMENT TIES AND TIE BARS SHALL BE EPOXY COATED IN CONFORMANCE WITH SUBSECTION 505.2.6.2 OF THE STANDARD SPECIFICATIONS.

INTEGRAL CURB AND GUTTER SHALL CONFORM TO THE DETAILS SHOWN FOR CONCRETE CURB AND GUTTER INCLUDING THE TRANSVERSE GUTTER SLOPE.

UNLESS OTHERWISE SHOWN ON THE TYPICAL CROSS SECTIONS, THE BASE AGGREGATE AND COMMON EXCAVATION LIMITS ARE 2' - 0" BEHIND THE BACK OF CURBS.

- ① TIE BARS ARE REQUIRED FOR CURB AND GUTTERS TYPES A, G, K, R, AND TBTT.
- ② THE BOTTOM OF CURB AND GUTTER MAY BE CONSTRUCTED EITHER LEVEL OR PARALLEL TO THE SLOPE OF THE SUBGRADE OR BASE AGGREGATE PROVIDED A 6" MINIMUM GUTTER THICKNESS IS MAINTAINED.
- ③ USE 8" MINIMUM GUTTER THICKNESS WHEN USED WITH AN ADJACENT CONCRETE TRUCK APRON PLACED BEHIND BACK OF CURB.
- ④ THE BOTTOM OF CURB AND GUTTER MAY BE CONSTRUCTED EITHER LEVEL OR PARALLEL TO THE SLOPE OF THE SUBGRADE OR BASE AGGREGATE PROVIDED A 8" MINIMUM GUTTER THICKNESS IS MAINTAINED.
- ⑤ UNLESS OTHERWISE NOTED, FOR STAKING PURPOSES THE FACE OF CURB IS 6" FROM THE BACK OF CURB.
- ⑥ WHEN REVERSE SLOPE GUTTER IS REQUIRED, THE LOCATION(S) WILL BE SHOWN ELSEWHERE IN THE PLAN.
- ⑦ USE 4% GUTTER CROSS SLOPE UNLESS OTHERWISE NOTED IN THE PLANS.
- ⑧ INCLUDE LONGITUDINAL JOINT AND TIE BARS ALONG LANE EDGE WHEN CONCRETE PANEL WIDTH EXCEEDS THE MAXIMUM WIDTH PER TABLE BELOW. LONGITUDINAL JOINT(S) ARE NOT ALLOWED WITHIN TRAFFIC LANES AND BIKE LANES. LONGITUDINAL JOINT MAY BE SAWED.
- ⑨ CONCRETE CURB AND GUTTER 4-INCH SLOPED 30-INCH TYPE "R" AND "T" = 17 INCHES
CONCRETE CURB AND GUTTER 4-INCH SLOPED 36-INCH TYPE "R" AND "T" = 23 INCHES

CONCRETE CURB AND GUTTER

STATE OF WISCONSIN
DEPARTMENT OF TRANSPORTATION

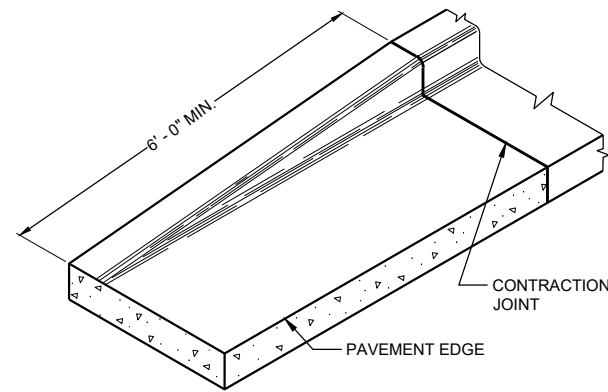

END SECTION CURB AND GUTTER

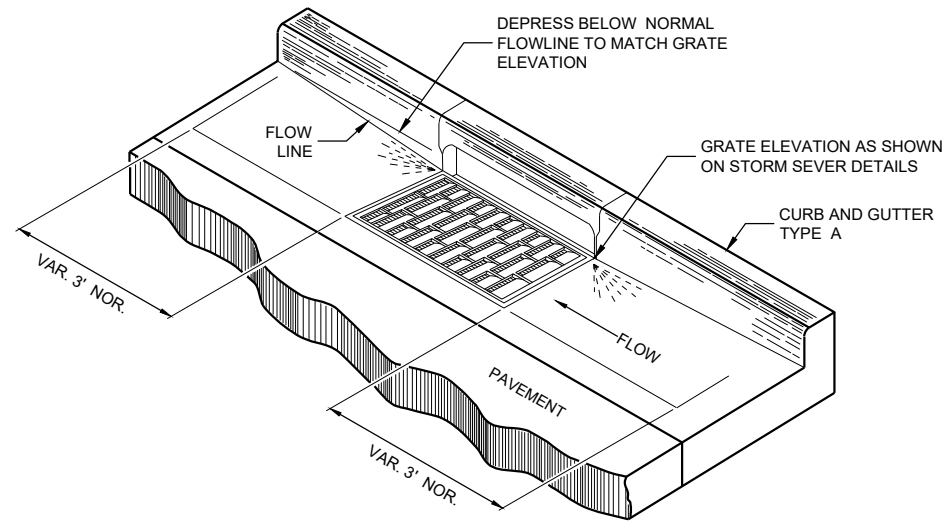

DETAIL OF CURB AND GUTTER AT INLETS

(TYPICAL H INLET COVER SHOWN)

GENERAL NOTES

DETAILS OF CONSTRUCTION AND WORKMANSHIP NOT SHOWN ON THIS DRAWING SHALL CONFORM TO THE PERTINENT REQUIREMENTS OF THE CONTRACT.

PAVEMENT TIES AND TIE BARS SHALL BE EPOXY COATED IN CONFORMANCE WITH SUBSECTION 505.2.6.2 OF THE STANDARD SPECIFICATIONS.

UNLESS OTHERWISE SHOWN ON THE TYPICAL CROSS SECTIONS, THE BASE AGGREGATE AND COMMON EXCAVATION LIMITS ARE 2' - 0" BEHIND THE BACK OF CURBS.

- ① TIE BARS ARE REQUIRED FOR CURB AND GUTTERS TYPES A, G, K, R, AND TBTT.
- ② THE BOTTOM OF CURB AND GUTTER MAY BE CONSTRUCTED EITHER LEVEL OR PARALLEL TO THE SLOPE OF THE SUBGRADE OR BASE AGGREGATE PROVIDED A 6" MINIMUM GUTTER THICKNESS IS MAINTAINED.
- ⑩ REFER TO SDD 08D18 AND 08D19 FOR ADDITIONAL DRIVEWAY ENTRANCE CURB DETAILS.
- ⑪ PLACE 1" THICK EXPANSION JOINT MATERIAL BETWEEN VERTICAL FACE CURB TYPES EXTENDING FROM THE TOP OF CURB TO 1 INCH BELOW THE ADJOINING CONCRETE SURFACE. RIGID CONCRETE STRUCTURES INCLUDE RAISED CONCRETE MEDIANS, CONCRETE SAFETY ISLANDS, SPLITTER ISLANDS, OR LOCATIONS IDENTIFIED ON THE PLANS.

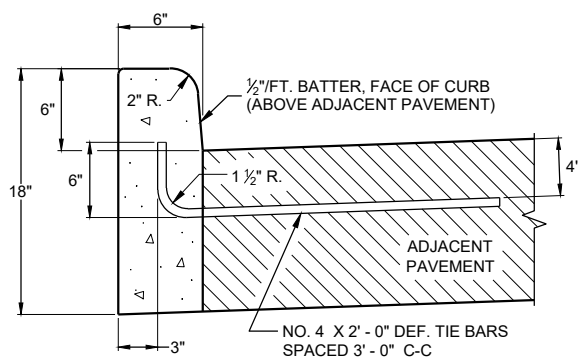

TYPES A^① & D

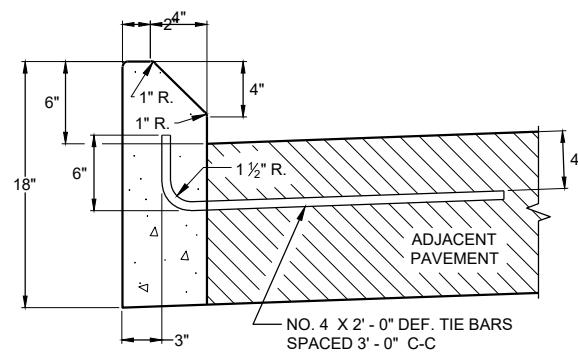

**TYPES G^① & J
CONCRETE CURB**

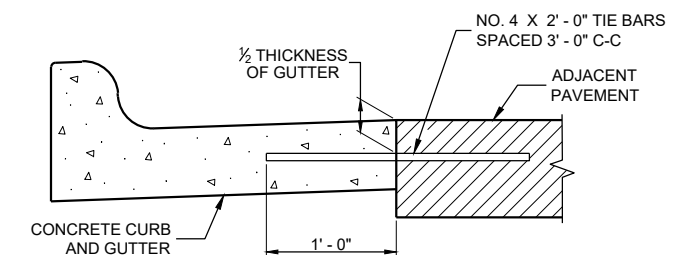

TYPICAL TIE BAR LOCATION^①

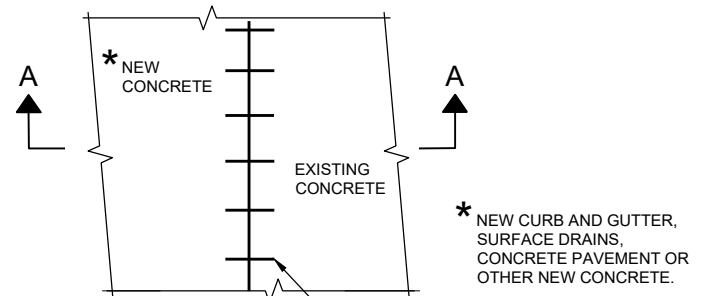

PLAN VIEW

* NEW CURB AND GUTTER, SURFACE DRAINS, CONCRETE PAVEMENT OR OTHER NEW CONCRETE.

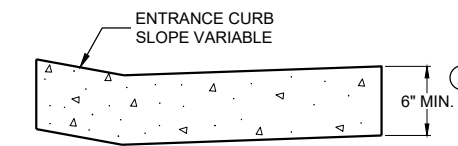

**DRIVEWAY ENTRANCE CURB^⑩
(WHEN DIRECTED BY THE ENGINEER)**

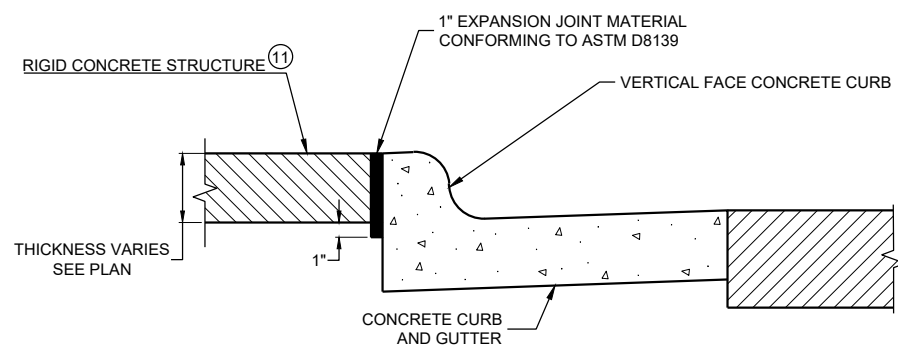

EXPANSION JOINT DETAIL FOR VERTICAL CURB ABUTTING A RIGID STRUCTURE^⑪

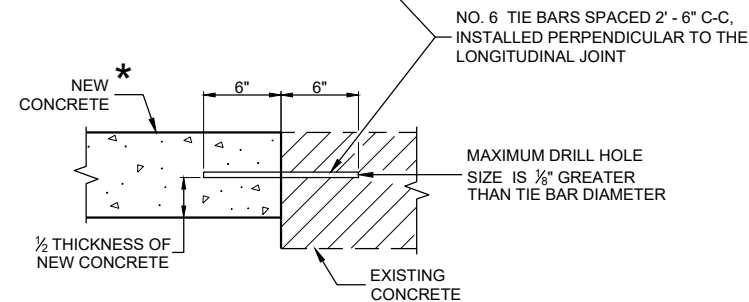

**SECTION A - A
TIE BARS DRILLED INTO EXISTING PAVEMENT**

CONCRETE CURB, TIES AND CURB AND GUTTER APPLICATIONS

STATE OF WISCONSIN
DEPARTMENT OF TRANSPORTATION

APPROVED
DATE May 2023 /S/ Rodney Taylor
ROADWAY STANDARDS DEVELOPMENT ENGINEER

FHWA

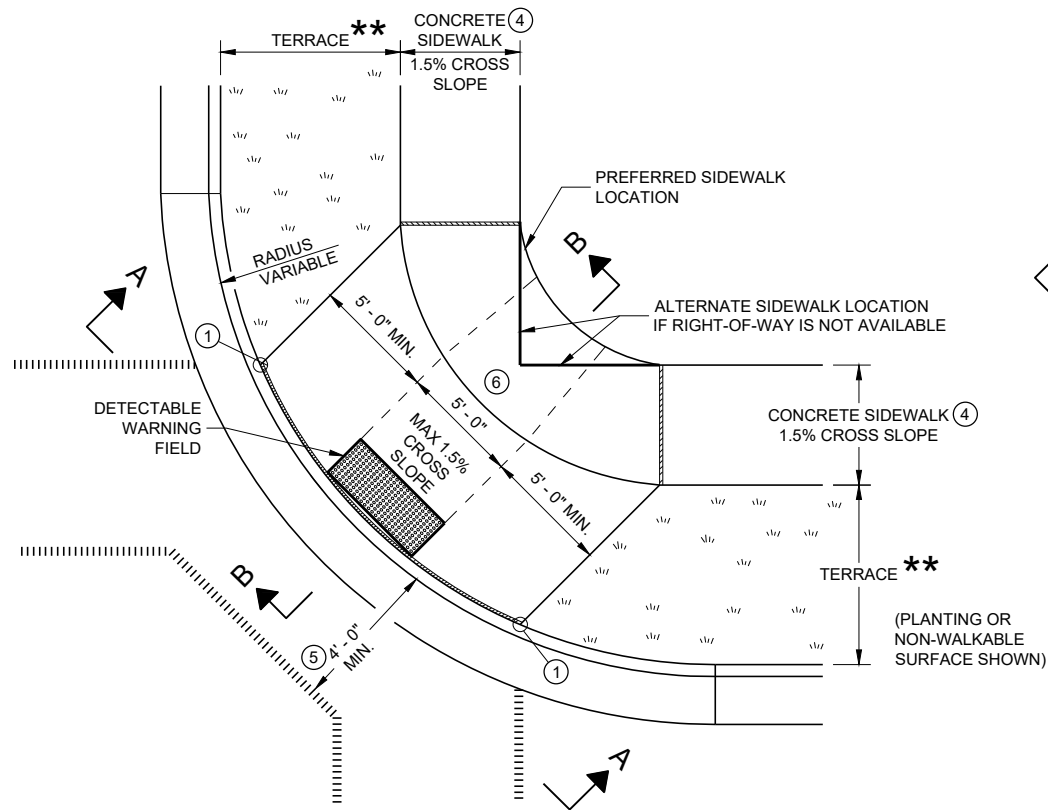

PLAN VIEW
CURB RAMP TYPE 1
(CENTER OF CORNER RADIUS)

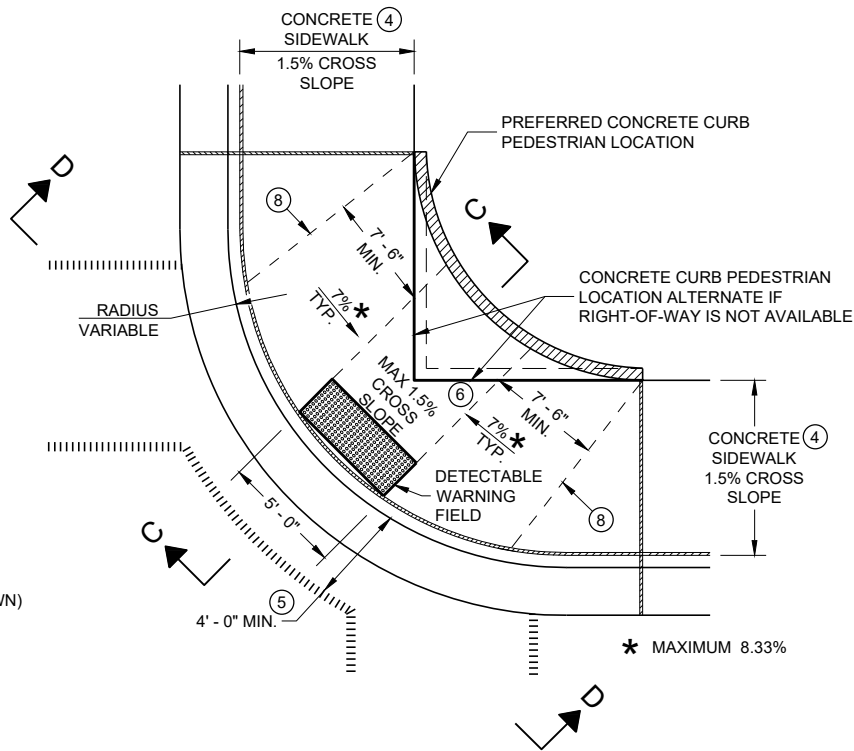

PLAN VIEW
CURB RAMP TYPE 1 - A
(NO TERRACE)

GENERAL NOTES

AVOID PLACING DRAINAGE STRUCTURES, JUNCTION BOXES OR OTHER OBSTRUCTIONS IN FRONT OF RAMP ACCESS AREAS.

DETAILS OF CONSTRUCTION, MATERIALS AND WORKMANSHIP NOT SHOWN ON THIS DRAWING SHALL CONFORM TO THE PERTINENT REQUIREMENTS OF THE STANDARD SPECIFICATIONS AND THE APPLICABLE SPECIAL PROVISIONS.

WHEN NECESSARY, THE SIDEWALK ELEVATION MAY BE LOWERED TO MEET THE HIGH POINT ON THE RAMP.

TYPE 1 CURB RAMPS SHALL HAVE A NORMAL SIDEWALK APRON AND CURB ON BOTH SIDES OF RAMP.

DETECTABLE WARNING FIELD SHALL BE MEASURED AND PAID BY THE SQUARE FOOT AS "CURB RAMP DETECTABLE WARNING FIELD". THE CONCRETE PEDESTRIAN CURB, IF NEEDED, SHALL BE MEASURED AND PAID BY THE LINEAR FOOT AS "CONCRETE CURB PEDESTRIAN". CONCRETE SIDEWALK IN THE CURB RAMP AREA SHALL BE MEASURED AND PAID BY THE SQUARE FOOT AS CONCRETE SIDEWALK, INCLUDING THE AREA UNDER THE DETECTABLE WARNING FIELD.

SELECT CURB RAMP DETECTABLE WARNING FIELD MATERIALS AND DEVICES FROM THE DEPARTMENT'S APPROVED MATERIALS LIST. THE COLOR OF THE DETECTABLE WARNING FIELD IS SPECIFIED ELSEWHERE AND IS INCIDENTAL TO THE BID ITEM OF "CURB RAMP DETECTABLE WARNING FIELD"

DETECTABLE WARNING FIELDS THAT ARE INSTALLED AS A GROUP OR SIDE BY SIDE, SHALL BE FROM THE SAME MANUFACTURER.

SURFACE TEXTURE OF THE RAMP SHALL BE OBTAINED BY COARSE BROOMING TRANSVERSE TO THE SLOPE OF THE RAMP.

- ① THIS POINT IS AN EXTENSION OF OUTSIDE EDGE OF APPROACHING SIDEWALK WHERE IT MEETS THE BACK OF CONCRETE CURB. POINT LOCATION MAY BE ADJUSTED TO ALIGN WITH BEGINNING OF FULL-HEIGHT CURB IF THIS DISTANCE IS SHORT.
- ② GRADE CHANGE BETWEEN GUTTER FLAG SLOPE AND THE CURB RAMP SLOPE SHALL NOT EXCEED 11%. MAXIMUM GUTTER FLAG SLOPE IS 4%. PROVIDE LONGITUDINAL DRAINAGE AROUND CURB AND AWAY FROM CURB RAMP. NO VERTICAL LIPS OR DISCONTINUITIES GREATER THAN 1/4" INCH ARE ALLOWED. SLOPE OF CURB HEAD OPENING SHALL MATCH THE RAMP SLOPE, MINIMALLY 1.5% AND NOT TO EXCEED 7%. WHEN ADJACENT TO 1.5% LANDING, CONSTRUCT CURB HEAD OPENING AT 1.5% IN THE DIRECTION OF PEDESTRIAN TRAVEL.
- ③ MAXIMUM 8.33% CURB RAMP SLOPE IS ALLOWABLE WITH FLATTENED GUTTER FLAG SLOPE AND NOT TO EXCEED 11% GRADE CHANGE.
- ④ ±0.5% CONSTRUCTION TOLERANCE IN SIDEWALK CROSS SLOPE. THE SIDEWALK CROSS SLOPE SHALL NOT EXCEED 2% WITHOUT PRIOR APPROVAL FROM THE ENGINEER.
- ⑤ PROVIDE A LEVEL LANDING IN THE STREET AND GUTTER AREA (2% MAXIMUM SLOPE IN ANY DIRECTION). WHEN THE GUTTER SLOPE EXCEEDS 2%, CONSTRUCT THE LEVEL LANDING IN THE STREET AREA.
- ⑥ PROVIDE A LEVEL LANDING (MAXIMUM 2% SLOPE) IN ANY DIRECTION OF PEDESTRIAN TRAVEL. STANDARD LEVEL LANDING SIZE IS 5 FEET BY 5 FEET.
- ⑧ PROVIDE GRADE BREAK PERPENDICULAR TO DIRECTION OF WHEELCHAIR TRAVEL.

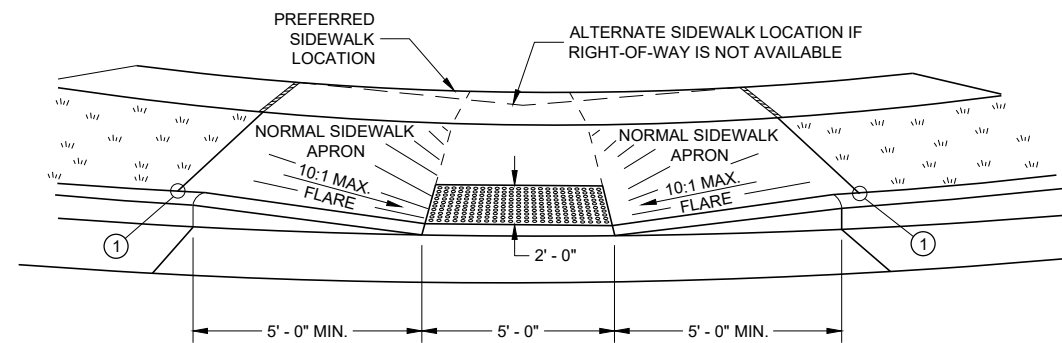

VIEW A - A FOR TYPE 1

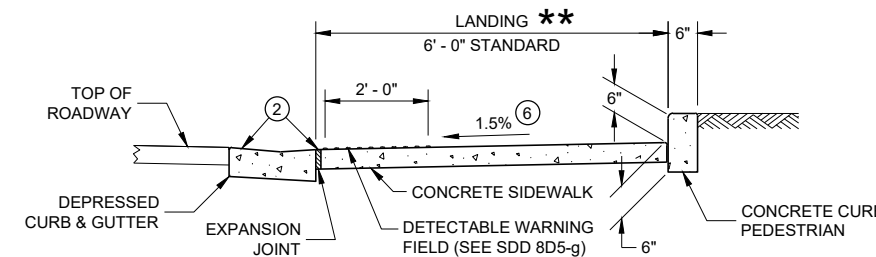

SECTION C - C FOR TYPE 1 - A

LEGEND

- 1/2" EXPANSION JOINT SIDEWALK
- - - - - CONTRACTION JOINT FIELD LOCATED
- ||||||| PAVEMENT MARKING CROSSWALK (WHITE)

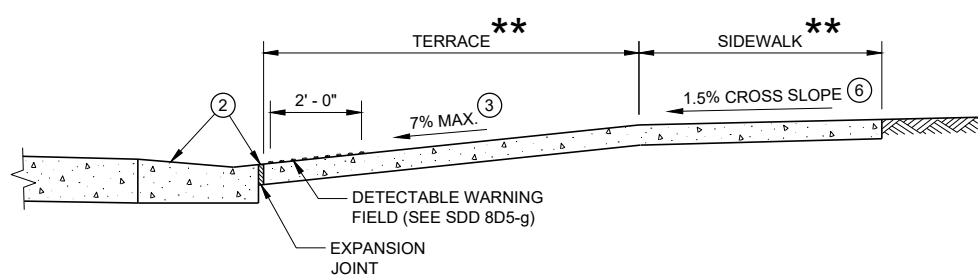

SECTION B - B FOR TYPE 1

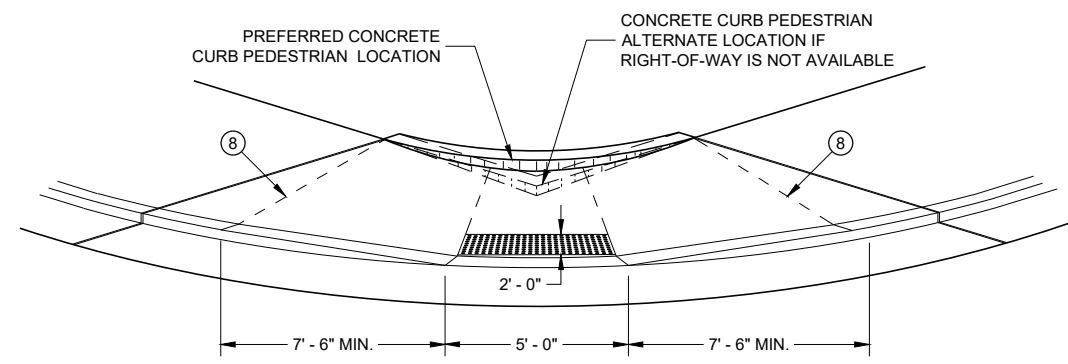

VIEW D - D FOR TYPE 1 - A

** WIDTH SHOWN ELSEWHERE IN THE PLANS

CURB RAMPS
TYPE 1 AND 1-A

STATE OF WISCONSIN
DEPARTMENT OF TRANSPORTATION

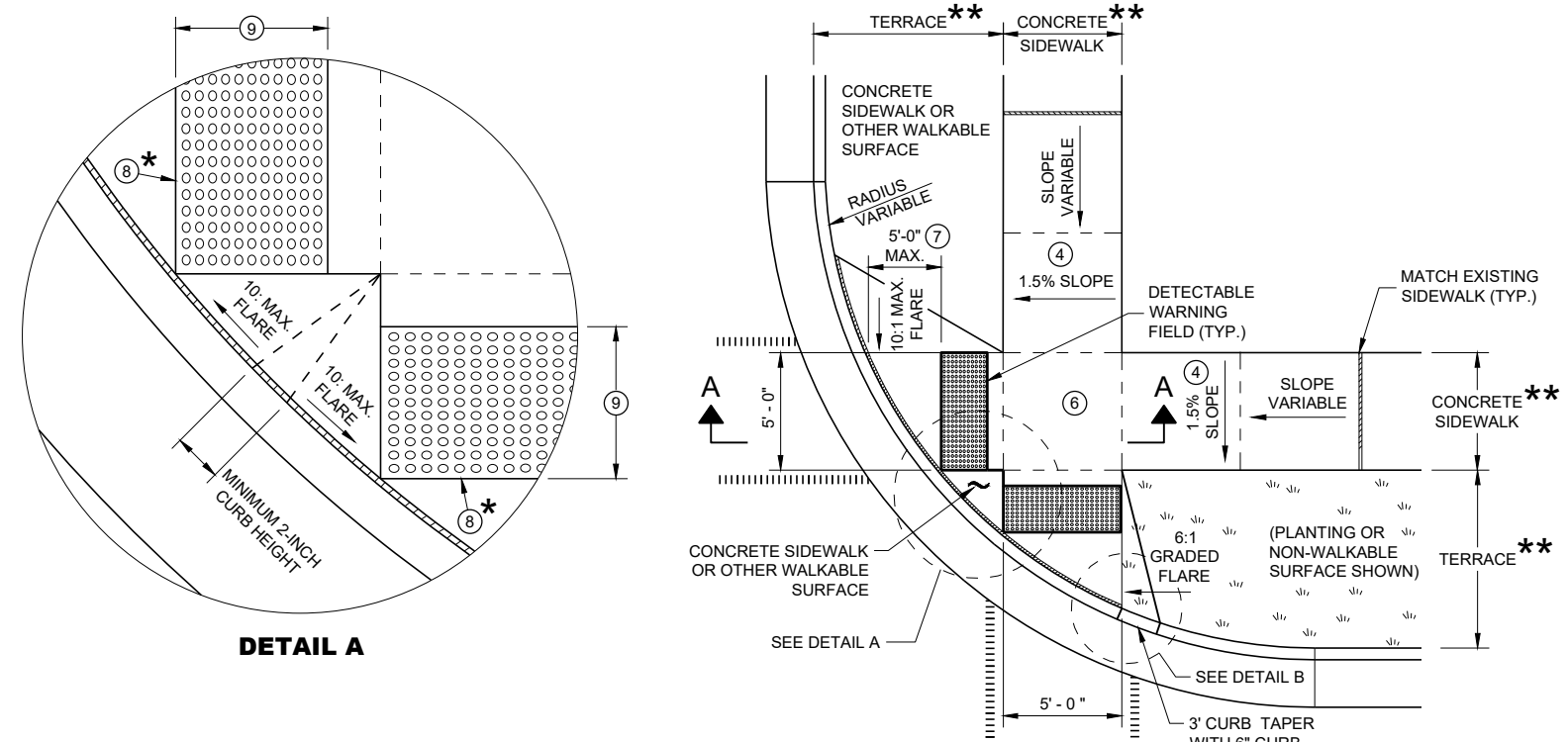

PLAN VIEW CURB RAMP TYPE 2 (CENTER OF CORNER RADIUS)

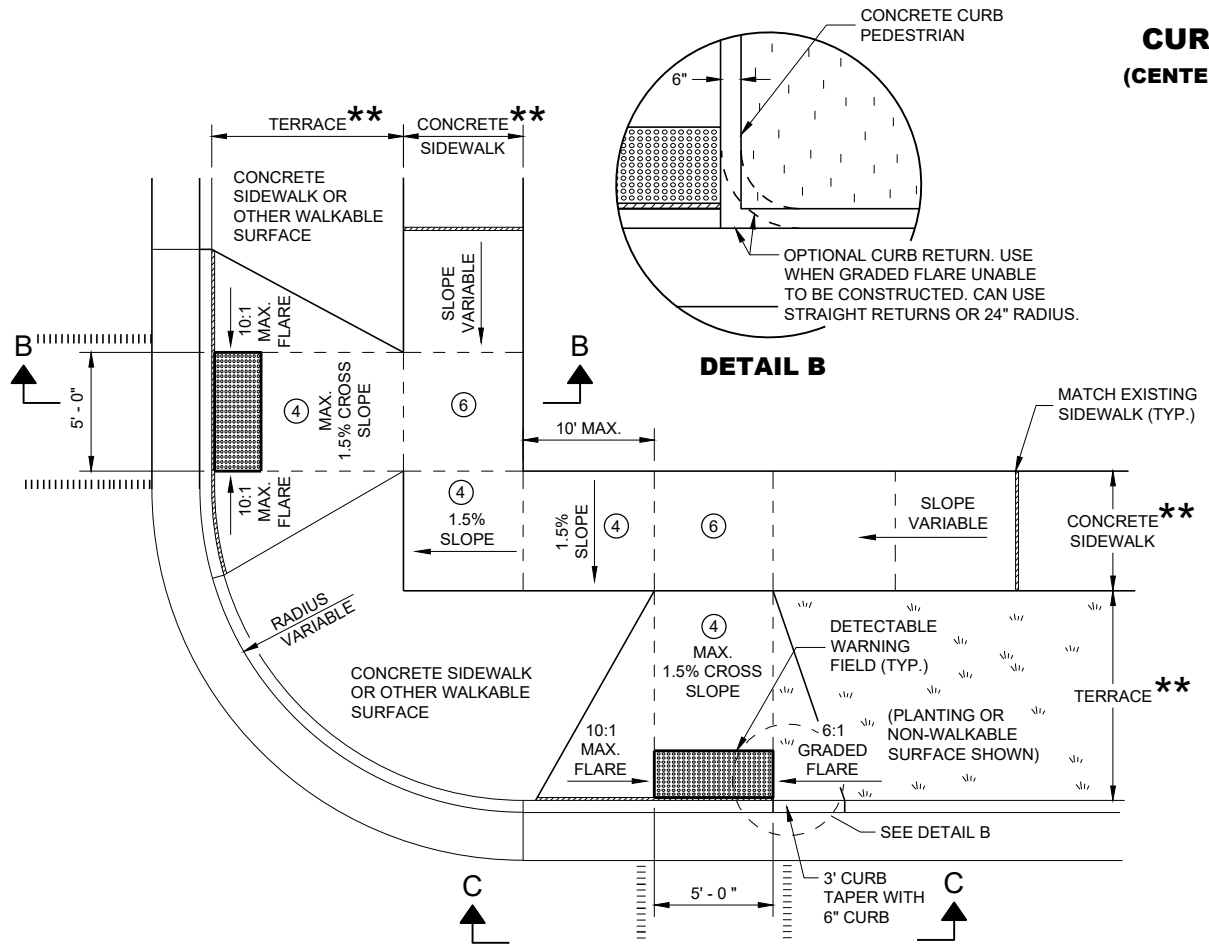

PLAN VIEW CURB RAMP TYPE 3 (OUTSIDE OF CROSSWALK AREA)

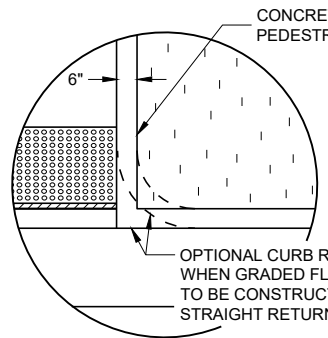

DETAIL B

GENERAL NOTES

- AVOID PLACING DRAINAGE STRUCTURES, JUNCTION BOXES OR OTHER OBSTRUCTIONS IN FRONT OF RAMP ACCESS AREAS.
- DETAILS OF CONSTRUCTION, MATERIALS AND WORKMANSHIP NOT SHOWN ON THIS DRAWING SHALL CONFORM TO THE PERTINENT REQUIREMENTS OF THE STANDARD SPECIFICATIONS AND THE APPLICABLE SPECIAL PROVISIONS.
- DETECTABLE WARNING FIELDS THAT ARE INSTALLED AS A GROUP OR SIDE BY SIDE SHALL BE FROM THE SAME MANUFACTURER.
- ② GRADE CHANGE BETWEEN GUTTER FLAG SLOPE AND THE CURB RAMP SLOPE SHALL NOT EXCEED 11%. MAXIMUM GUTTER FLAG SLOPE IS 4%. PROVIDE LONGITUDINAL DRAINAGE AROUND CURB AND AWAY FROM CURB RAMP. NO VERTICAL LIPS OR DISCONTINUITIES GREATER THAN 1/4 - INCH ARE ALLOWED. SLOPE OF CURB HEAD OPENING SHALL MATCH THE RAMP SLOPE, MINIMALLY 1.5% AND NOT TO EXCEED 7%. WHEN ADJACENT TO 1.5% LANDING, CONSTRUCT CURB HEAD OPENING AT 1.5% IN THE DIRECTION OF PEDESTRIAN TRAVEL.
- ③ AN 8.33% CURB RAMP SLOPE IS ALLOWABLE WITH FLATTENED GUTTER FLAG SLOPE (2.67% OR LESS) AND NOT TO EXCEED 11% GRADE CHANGE.
- ④ ±0.5% CONSTRUCTION TOLERANCE IN SIDEWALK CROSS SLOPE. THE SIDEWALK CROSS SLOPE SHALL NOT EXCEED 2% WITHOUT PRIOR APPROVAL FROM THE ENGINEER.
- ⑥ PROVIDE A LEVEL LANDING (MAXIMUM 2% SLOPE) IN ANY DIRECTION OF PEDESTRIAN TRAVEL. STANDARD LEVEL LANDING SIZE IS 5 FEET X 5 FEET.
- ⑦ WHEN GRADE BREAK DISTANCE EXCEEDS 5 FEET, USE RADIAL DETECTABLE WARNING FIELD PER SDD 8D5-f.
- ⑧ PROVIDE GRADE BREAK PERPENDICULAR TO DIRECTION OF WHEELCHAIR TRAVEL.
- ⑨ WHEN DISTANCE IS LESS THAN 6' - 0", IT MAY BE DIFFICULT TO ACHIEVE A 7% SLOPE OR FLATTER ALONG THE RAMP. REDUCE CURB HEIGHT IN TRIANGLE AREA TO ACHIEVE 7% SLOPE OR FLATTER ON RAMP. CONSTRUCT 2-INCH MINIMUM CURB HEIGHT BETWEEN 10:1 FLARES.

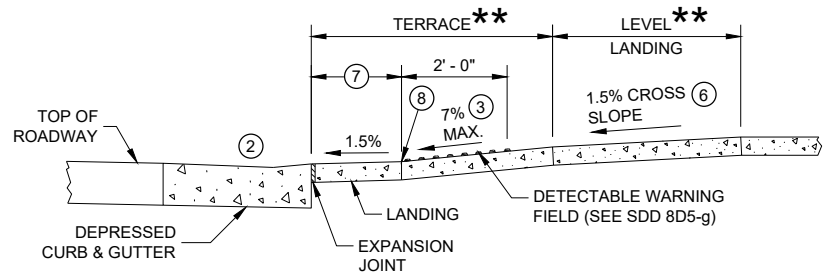

SECTION A - A FOR TYPE 2

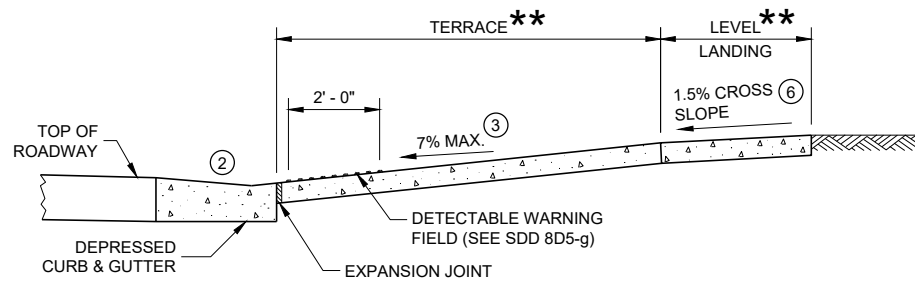

SECTION B - B FOR TYPE 3

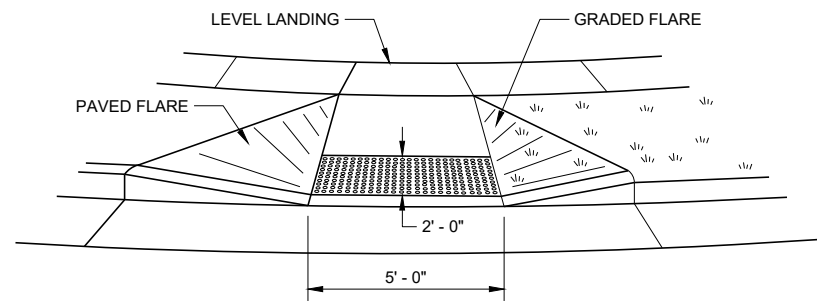

VIEW C - C FOR TYPE 3

- * MAXIMUM 2.0% SLOPE IN ALL DIRECTIONS IN FRONT OF GRADE BREAK
- ** WIDTH SHOWN ELSEWHERE IN THE PLANS

LEGEND

- 1/2" EXPANSION JOINT SIDEWALK
- - - - - CONTRACTION JOINT SIDEWALK
- ||||| PAVEMENT MARKING CROSSWALK (WHITE)

**CURB RAMPS
TYPE 2 AND 3**

STATE OF WISCONSIN
DEPARTMENT OF TRANSPORTATION

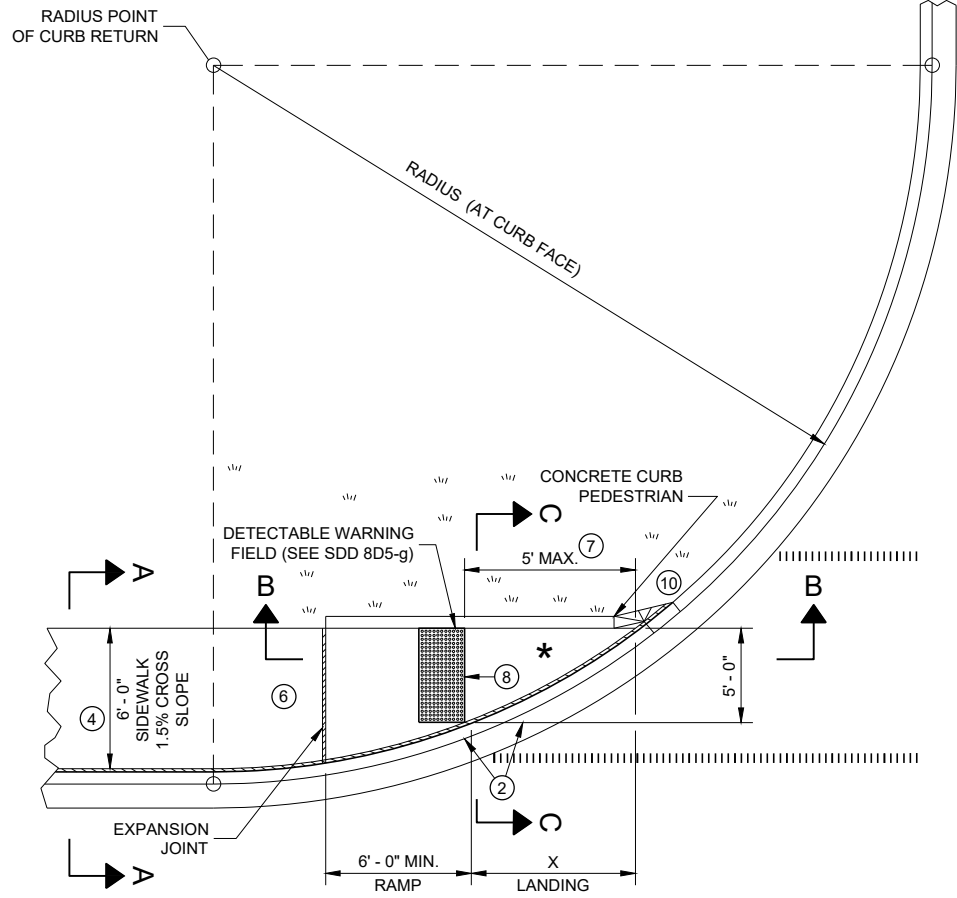

**PLAN VIEW
CURB RAMP TYPE 4A**

RADIUS (AT CURB FACE)	X
10 FEET	4' - 7"
15 FEET	6' - 5 1/2"

INTERMEDIATE RADII CAN BE INTERPOLATED

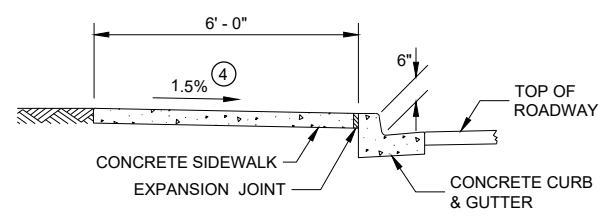

SECTION A - A FOR TYPE 4A

GENERAL NOTES

- AVOID PLACING DRAINAGE STRUCTURES, JUNCTION BOXES OR OTHER OBSTRUCTIONS IN FRONT OF RAMP ACCESS AREAS.
- DETAILS OF CONSTRUCTION, MATERIALS AND WORKMANSHIP NOT SHOWN ON THIS DRAWING SHALL CONFORM TO THE PERTINENT REQUIREMENTS OF THE STANDARD SPECIFICATIONS AND THE APPLICABLE SPECIAL PROVISIONS.
- DETECTABLE WARNING FIELDS THAT ARE INSTALLED AS A GROUP OR SIDE BY SIDE, SHALL BE FROM THE SAME MANUFACTURER.
- ② GRADE CHANGE BETWEEN GUTTER FLAG SLOPE AND THE CURB RAMP SLOPE SHALL NOT EXCEED 11%. MAXIMUM GUTTER FLAG SLOPE IS 4%. PROVIDE LONGITUDINAL DRAINAGE AROUND CURB AND AWAY FROM CURB RAMP. NO VERTICAL LIPS OR DISCONTINUITIES GREATER THAN 1/4" INCH ARE ALLOWED. SLOPE OF CURB HEAD OPENING SHALL MATCH THE RAMP SLOPE, MINIMALLY 1.5% AND NOT TO EXCEED 7%. WHEN ADJACENT TO 1.5% LANDING, CONSTRUCT CURB HEAD OPENING AT 1.5% IN THE DIRECTION OF PEDESTRIAN TRAVEL.
- ③ AN 8.33% CURB RAMP SLOPE IS ALLOWABLE WITH FLATTENED GUTTER FLAG SLOPE AND NOT TO EXCEED 11% GRADE CHANGE.
- ④ ±0.5% CONSTRUCTION TOLERANCE IN SIDEWALK CROSS SLOPE. THE SIDEWALK CROSS SLOPE SHALL NOT EXCEED 2% WITHOUT PRIOR APPROVAL FROM THE ENGINEER.
- ⑥ PROVIDE A LEVEL LANDING (MAXIMUM 2% SLOPE) IN ANY DIRECTION OF PEDESTRIAN TRAVEL. STANDARD LEVEL LANDING SIZE IS 5 FEET BY 5 FEET.
- ⑦ WHEN THIS GRADE BREAK DISTANCE EXCEEDS 5 FEET, USE RADIAL DETECTABLE WARNING FIELD PER SDD 8D5-f.
- ⑧ PROVIDE GRADE BREAK PERPENDICULAR TO DIRECTION OF WHEELCHAIR TRAVEL.
- ⑩ INSTALL TRANSITION NOSE (INCIDENTAL TO OTHER PAY ITEMS). DO NOT MARK TRANSITION NOSE.

LEGEND

- 1/2" EXPANSION JOINT SIDEWALK
- CONTRACTION JOINT SIDEWALK
- PAVEMENT MARKING CROSSWALK (WHITE)

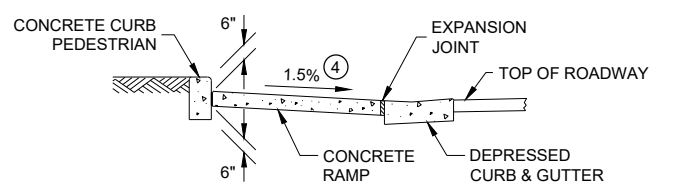

SECTION C - C FOR TYPE 4A

* MAXIMUM 2.0% SLOPE IN ALL DIRECTIONS IF FRONT OF GRADE BREAK

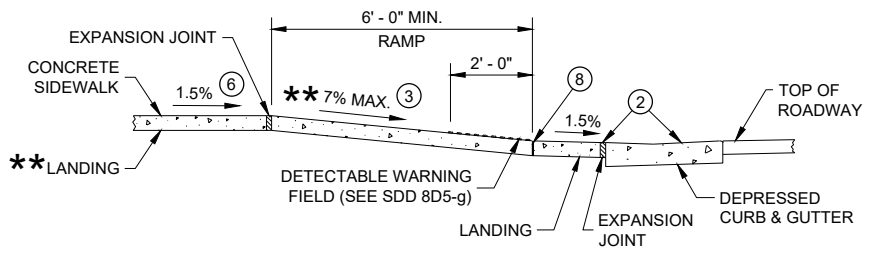

**SECTION B - B FOR
TYPE 4A AND TYPE 4A1**

** IF RAMP SLOPE IS LESS THAN 5.0%, THEN NO ADJACENT UPHILL LANDING IS REQUIRED

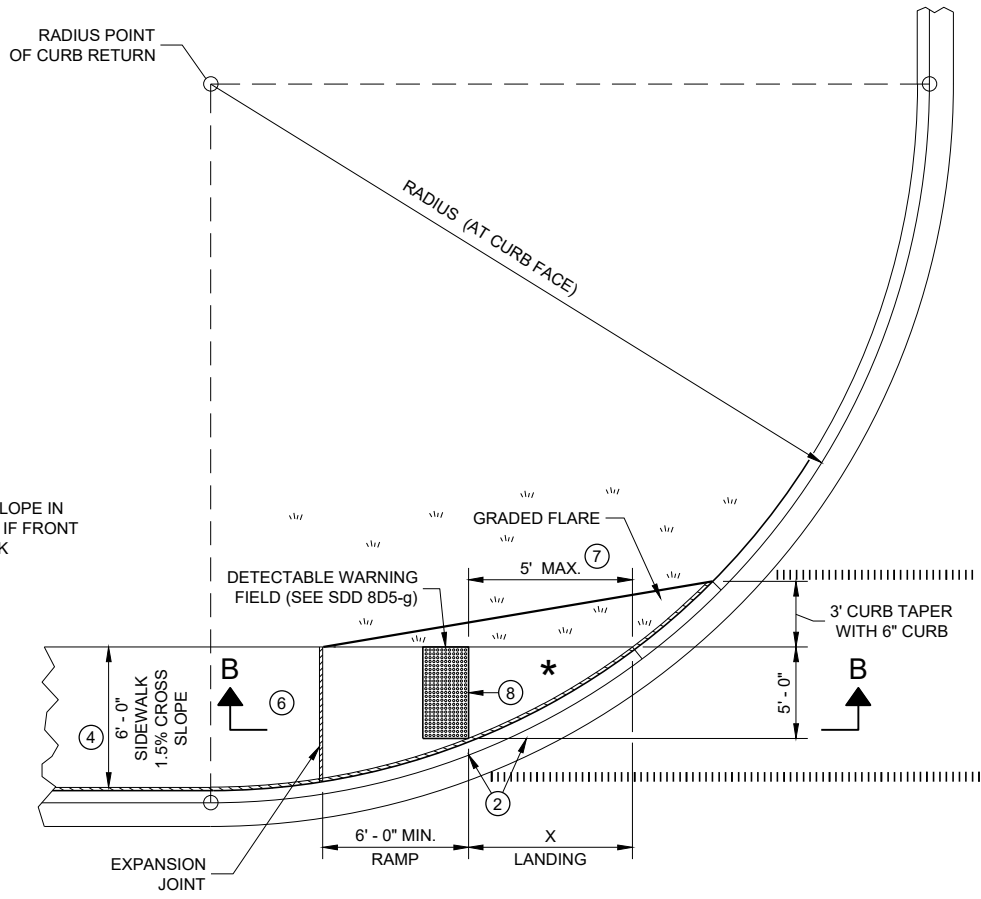

**PLAN VIEW
CURB RAMP TYPE 4A1**

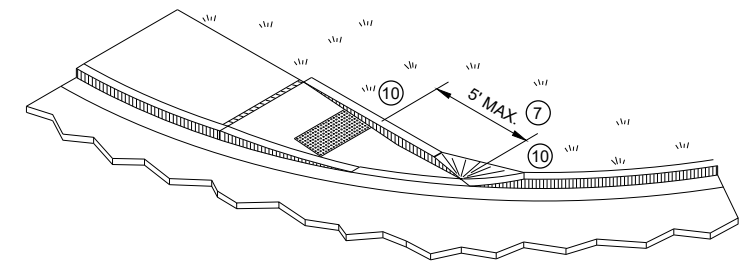

ISOMETRIC VIEW FOR TYPE 4A

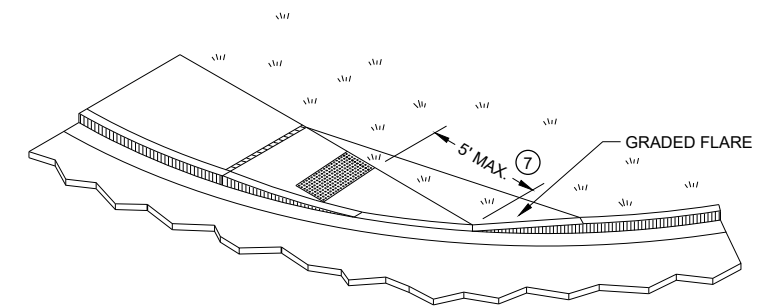

ISOMETRIC VIEW FOR TYPE 4A1

**CURB RAMPS
TYPE 4A AND 4A1**

STATE OF WISCONSIN
DEPARTMENT OF TRANSPORTATION

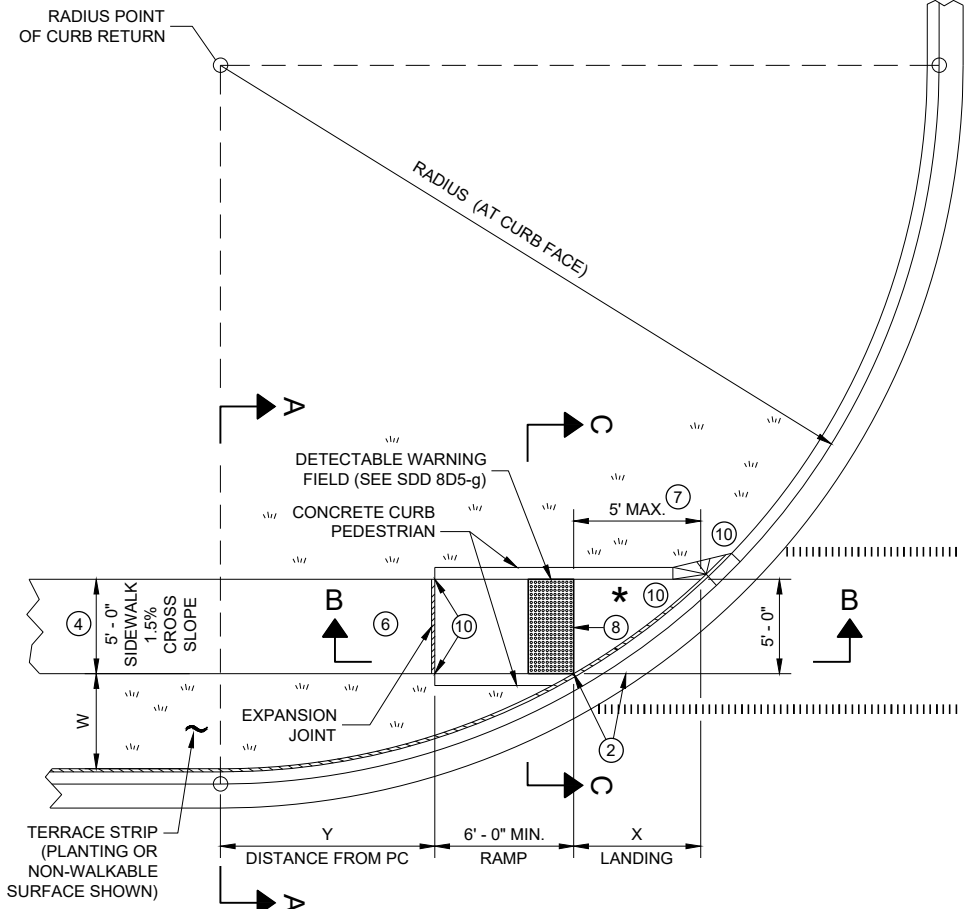

PLAN VIEW CURB RAMP TYPE 4B

RADIUS (AT CURB FACE)	W = 3' - 0"		W = 4' - 0"		W = 5' - 0"		W = 6' - 0"		W = 7' - 0"		W = 8' - 0"		W = 9' - 0"		W = 10' - 0"	
	X	Y	X	Y	X	Y	X	Y	X	Y	X	Y	X	Y	X	Y
10 FEET	2' - 10 1/4"	0' - 5"	2' - 1"	1' - 4 1/2"	1' - 5"	2' - 1"	0' - 10"	2' - 7 1/2"	0' - 3 1/4"	3' - 0 1/4"						
15 FEET	4' - 6 3/4"	2' - 1 3/4"	3' - 9"	3' - 5 3/4"	3' - 1 1/4"	4' - 6"	2' - 6 3/4"	5' - 4 1/2"	2' - 1"	6' - 1"	1' - 8"	6' - 8 1/2"	1' - 3 1/4"	7' - 2 1/2"	0' - 10 3/4"	7' - 7 1/4"
20 FEET	5' - 9 3/4"	3' - 6 1/2"	4' - 11 1/2"	5' - 1 3/4"	4' - 3 1/4"	6' - 5 1/2"	3' - 8 3/4"	7' - 7"	3' - 3"	8' - 6 1/2"	2' - 10"	9' - 4 1/2"	2' - 5 1/2"	10' - 1 1/4"	2' - 1 1/4"	10' - 9"
30 FEET			6' - 9 1/4"	7' - 11 1/4"	6' - 0 1/4"	9' - 8"	5' - 5"	11' - 1 3/4"	4' - 10 3/4"	12' - 5 3/4"	4' - 5 1/2"	13' - 7 3/4"	4' - 0 3/4"	14' - 8 1/2"	3' - 8 1/2"	15' - 8 1/4"
40 FEET									6' - 1 3/4"	15' - 8 1/2"	5' - 8"	17' - 2"	5' - 3"	18' - 5 3/4"	4' - 10 3/4"	19' - 8 1/4"
50 FEET															5' - 10 1/4"	23' - 2"

INTERMEDIATE RADII CAN BE INTERPOLATED
 DIMENSION "Y" IS CALCULATED BASED ON 6'-0" RAMP LENGTH
 DIMENSION "X" IS CALCULATED BASED ON 5'-0" SIDEWALK WIDTH

LEGEND

- 1/2" EXPANSION JOINT SIDEWALK
- CONTRACTION JOINT SIDEWALK
- PAVEMENT MARKING CROSSWALK (WHITE)

GENERAL NOTES

- AVOID PLACING DRAINAGE STRUCTURES, JUNCTION BOXES OR OTHER OBSTRUCTIONS IN FRONT OF RAMP ACCESS AREAS.
- DETAILS OF CONSTRUCTION, MATERIALS AND WORKMANSHIP NOT SHOWN ON THIS DRAWING SHALL CONFORM TO THE PERTINENT REQUIREMENTS OF THE STANDARD SPECIFICATIONS AND THE APPLICABLE SPECIAL PROVISIONS.
- DETECTABLE WARNING FIELDS THAT ARE INSTALLED AS A GROUP OR SIDE BY SIDE, SHALL BE FROM THE SAME MANUFACTURER.
- ② GRADE CHANGE BETWEEN GUTTER FLAG SLOPE AND THE CURB RAMP SLOPE SHALL NOT EXCEED 11%. MAXIMUM GUTTER FLAG SLOPE IS 4%. PROVIDE LONGITUDINAL DRAINAGE AROUND CURB AND AWAY FROM CURB RAMP. NO VERTICAL LIPS OR DISCONTINUITIES GREATER THAN 1/2 - INCH ARE ALLOWED. SLOPE OF CURB HEAD OPENING SHALL MATCH THE RAMP SLOPE, MINIMALLY 1.5% AND NOT TO EXCEED 7%. WHEN ADJACENT TO 1.5% LANDING, CONSTRUCT CURB HEAD OPENING AT 1.5% IN THE DIRECTION OF PEDESTRIAN TRAVEL.
- ③ AN 8.33% CURB RAMP SLOPE IS ALLOWABLE WITH FLATTENED GUTTER FLAG SLOPE AND NOT TO EXCEED 11% GRADE CHANGE.
- ④ ±0.5% CONSTRUCTION TOLERANCE IN SIDEWALK CROSS SLOPE. THE SIDEWALK CROSS SLOPE SHALL NOT EXCEED 2% WITHOUT PRIOR APPROVAL FROM THE ENGINEER.
- ⑥ PROVIDE A LEVEL LANDING (MAXIMUM 2% SLOPE) IN ANY DIRECTION OF PEDESTRIAN TRAVEL. STANDARD LEVEL LANDING SIZE IS 5 FEET BY 5 FEET.
- ⑦ WHEN THIS GRADE BREAK DISTANCE EXCEEDS 5 FEET, USE RADIAL DETECTABLE WARNING FIELD PER SDD 8D5-f.
- ⑧ PROVIDE GRADE BREAK PERPENDICULAR TO DIRECTION OF WHEELCHAIR TRAVEL.
- ⑩ INSTALL TRANSITION NOSE (INCIDENTAL TO OTHER PAY ITEMS). DO NOT MARK TRANSITION NOSE.

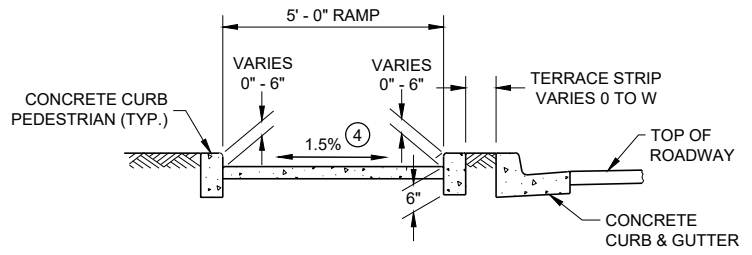

SECTION C - C FOR TYPE 4B

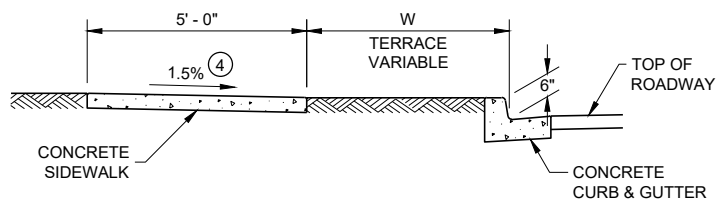

SECTION A - A FOR TYPE 4B

* MAXIMUM 2.0% SLOPE IN ALL DIRECTIONS IF FRONT OF GRADE BREAK

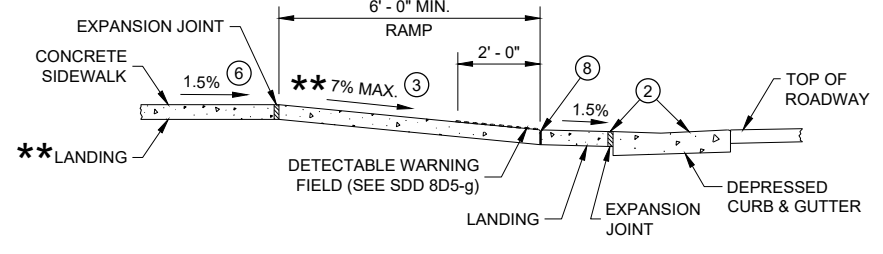

SECTION B - B FOR TYPE 4B AND TYPE 4B1

** IF RAMP SLOPE IS LESS THAN 5.0%, THEN NO ADJACENT UPHILL LANDING IS REQUIRED

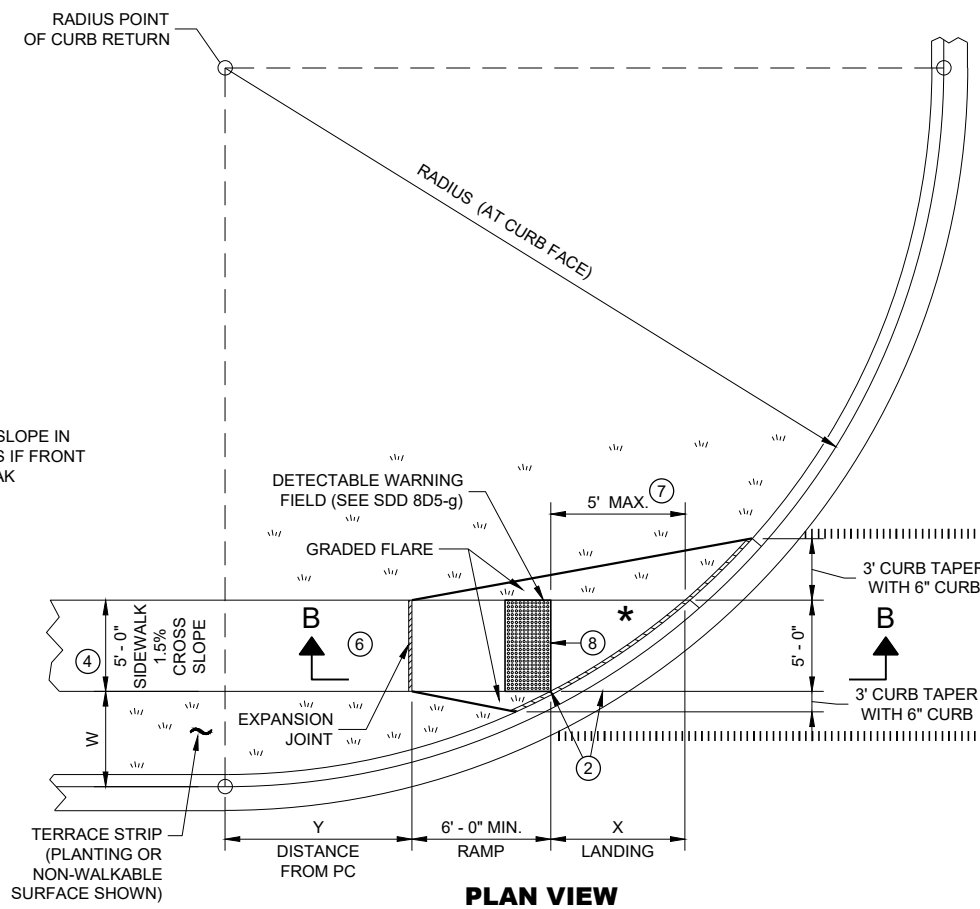

PLAN VIEW CURB RAMP TYPE 4B1

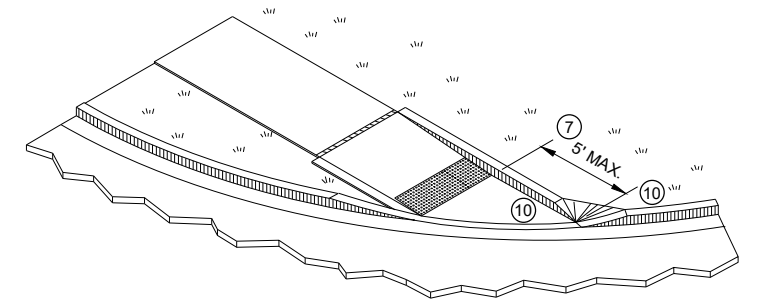

ISOMETRIC VIEW FOR TYPE 4B

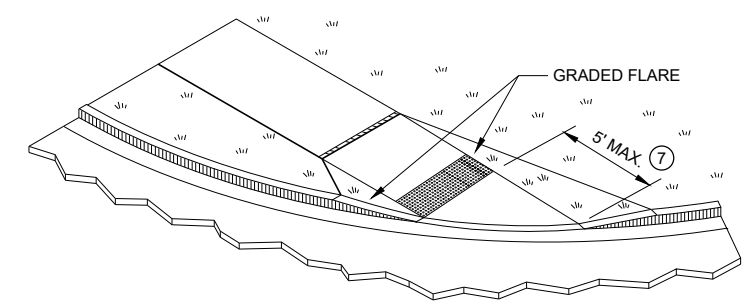

ISOMETRIC VIEW FOR TYPE 4B1

CURB RAMPS TYPE 4B AND 4B1

STATE OF WISCONSIN
 DEPARTMENT OF TRANSPORTATION

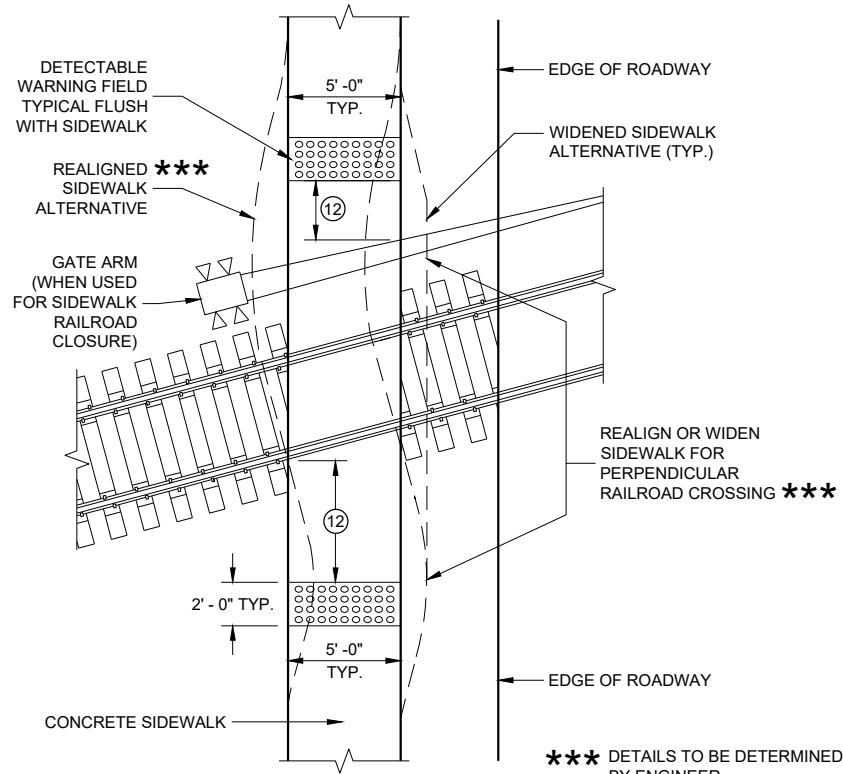

CURB RAMP TYPE 8

DETECTABLE WARNINGS AT RAILROAD CROSSING

*** DETAILS TO BE DETERMINED BY ENGINEER

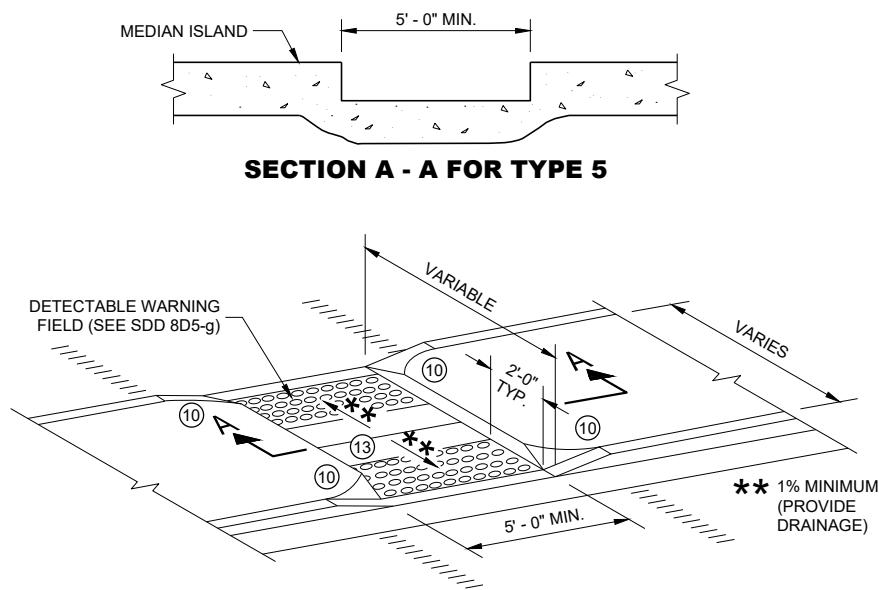

CURB RAMP TYPE 5
MEDIAN ISLAND
NON-ELEVATED PEDESTRIAN CROSSING

GENERAL NOTES

AVOID PLACING DRAINAGE STRUCTURES, JUNCTION BOXES OR OTHER OBSTRUCTIONS IN FRONT OF RAMP ACCESS AREAS.

DETAILS OF CONSTRUCTION, MATERIALS AND WORKMANSHIP NOT SHOWN ON THIS DRAWING SHALL CONFORM TO THE PERTINENT REQUIREMENTS OF THE STANDARD SPECIFICATIONS AND THE APPLICABLE SPECIAL PROVISIONS.

SIDEWALK CROSS SLOPE SHALL NOT EXCEED 2%.

DETECTABLE WARNING FIELDS THAT ARE INSTALLED AS A GROUP OR SIDE BY SIDE, SHALL BE FROM THE SAME MANUFACTURER.

- ② GRADE CHANGE BETWEEN GUTTER FLAG SLOPE AND THE CURB RAMP SLOPE SHALL NOT EXCEED 11%. MAXIMUM GUTTER FLAG SLOPE IS 4%. PROVIDE LONGITUDINAL DRAINAGE AROUND CURB AND AWAY FROM CURB RAMP. NO VERTICAL LIPS OR DISCONTINUITIES GREATER THAN 1/4 - INCH ARE ALLOWED. SLOPE OF CURB HEAD OPENING SHALL MATCH THE RAMP SLOPE, MINIMALLY 1.5% AND NOT TO EXCEED 7%. WHEN ADJACENT TO 1.5% LANDING, CONSTRUCT CURB HEAD OPENING AT 1.5% IN THE DIRECTION OF PEDESTRIAN TRAVEL.
- ③ AN 8.33% CURB RAMP SLOPE IS ALLOWABLE WITH FLATTENED GUTTER FLAG SLOPE AND NOT TO EXCEED 11% GRADE CHANGE.
- ④ ±0.5% CONSTRUCTION TOLERANCE IN SIDEWALK CROSS SLOPE. THE SIDEWALK CROSS SLOPE SHALL NOT EXCEED 2% WITHOUT PRIOR APPROVAL FROM THE ENGINEER.
- ⑥ PROVIDE A LEVEL LANDING (MAXIMUM 2% SLOPE) IN ANY DIRECTION OF PEDESTRIAN TRAVEL. STANDARD LEVEL LANDING SIZE IS 5 FEET BY 5 FEET.
- ⑩ INSTALL TRANSITION NOSE (INCIDENTAL TO OTHER PAY ITEMS). DO NOT MARK TRANSITION NOSE.
- ⑪ SLOPE SIDEWALK TOWARD LANDING AS SHOWN WHERE THERE IS NO TERRACE OR WHERE THE TERRACE WIDTH IS LESS THAN 6 FEET WIDE.
- ⑫ THE EDGE OF THE DETECTABLE WARNING FIELD NEAREST TO A RAILROAD CROSSING SHALL BE 1.5 FEET ±0.1' FROM THE FACE OF THE GATE ARM IF THE GATE ARM EXTENDS ACROSS THE SIDEWALK. WHERE THERE IS NO PEDESTRIAN GATE, THE EDGE OF THE DETECTABLE WARNING FIELD NEAREST TO THE RAILROAD CROSSING SHALL BE 15 FEET FROM THE NEAREST RAIL.
- ⑬ DO NOT INSTALL DETECTABLE WARNING FIELDS AT THE EDGES OF STREET-LEVEL PEDESTRIAN REFUGE ISLANDS IF A MINIMUM 2 FOOT CONCRETE SURFACE WITHOUT DETECTABLE WARNINGS (MEASURED IN THE DIRECTION OF PEDESTRIAN TRAVEL) CANNOT BE ACHIEVED.

LEGEND

- ===== 1/2" EXPANSION JOINT SIDEWALK
- - - - - CONTRACTION JOINT FIELD LOCATED
- ||||||| PAVEMENT MARKING CROSSWALK (WHITE)

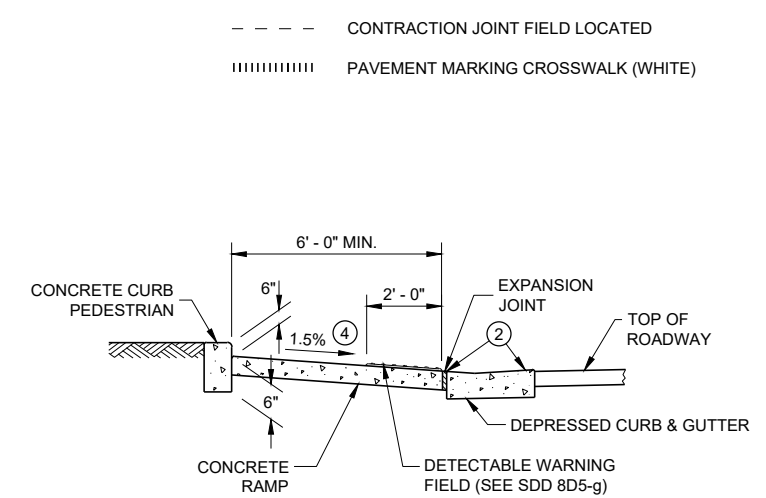

CURB RAMP TYPE 7A
MID BLOCK CROSSING

SECTION B - B FOR TYPE 7A

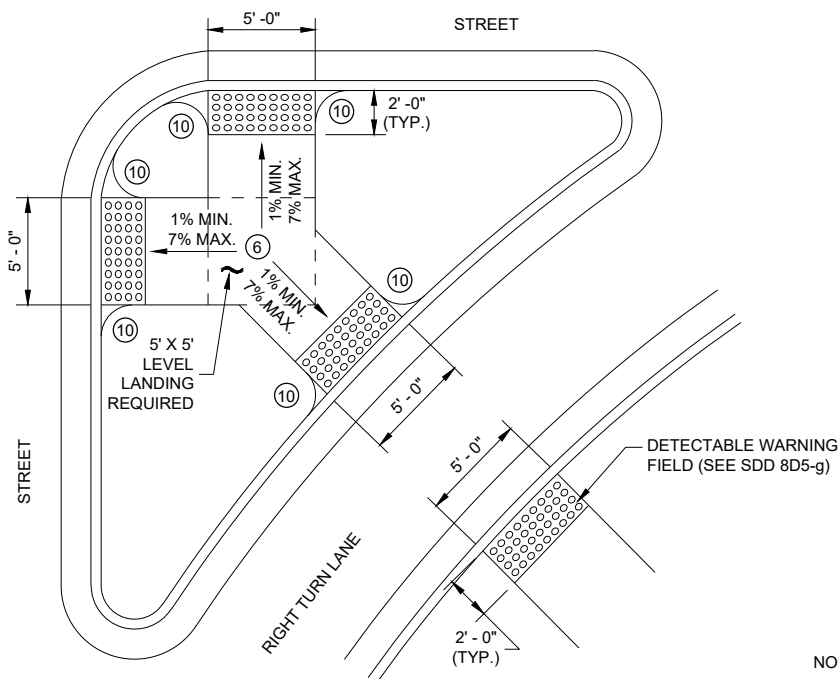

CURB RAMP TYPE 6
DETECTABLE WARNING AT ISLANDS

REFER TO GENERAL NOTES ② AND ③ FOR ALL ISLAND CURB RAMPS

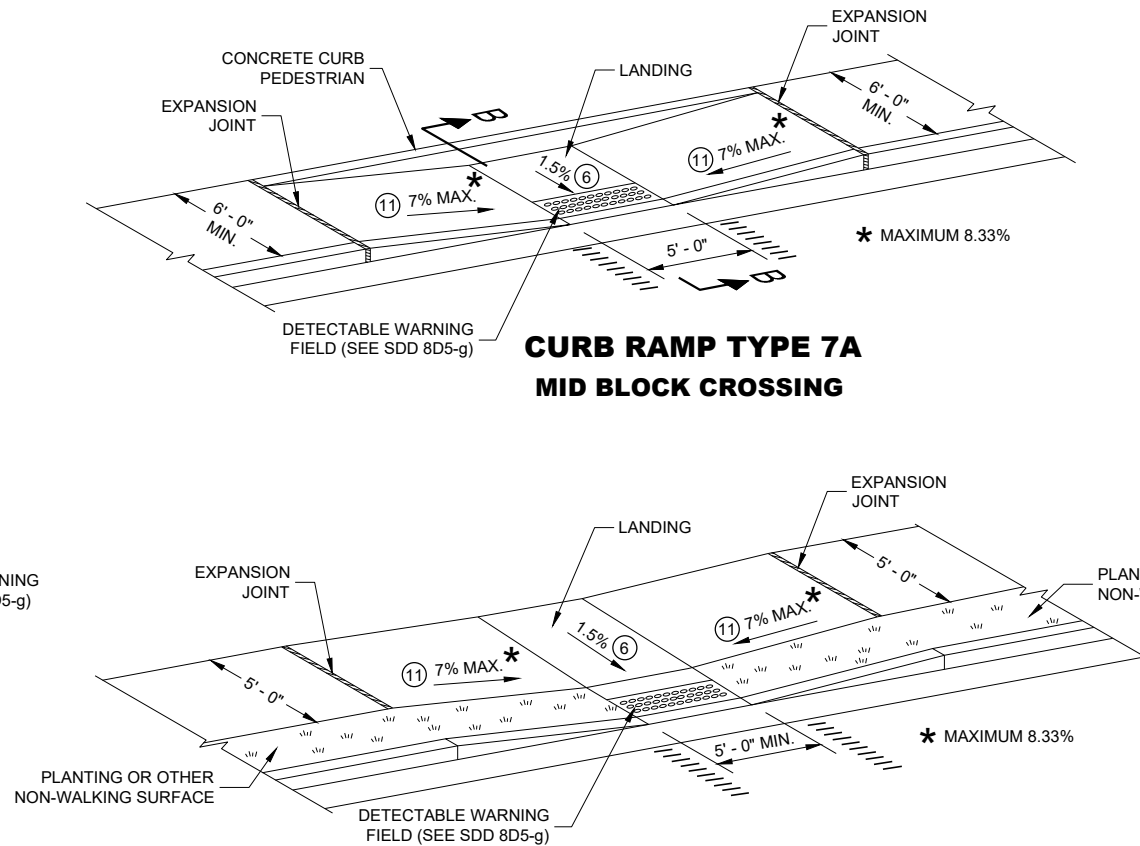

CURB RAMP TYPE 7B
MID BLOCK CROSSING

NOTE: THESE PARALLEL AND PARALLEL/PERPENDICULAR CURB RAMPS MAY BE USED AT INTERSECTIONS AND MID BLOCK LOCATIONS.

CURB RAMPS
TYPE 5, 6, 7A, 7B & 8

STATE OF WISCONSIN
DEPARTMENT OF TRANSPORTATION

RADIAL DETECTABLE WARNING FIELD PLACEMENT WHEN 5 FOOT GRADE BREAK DISTANCE PER SDD 8D5-c IS EXCEEDED

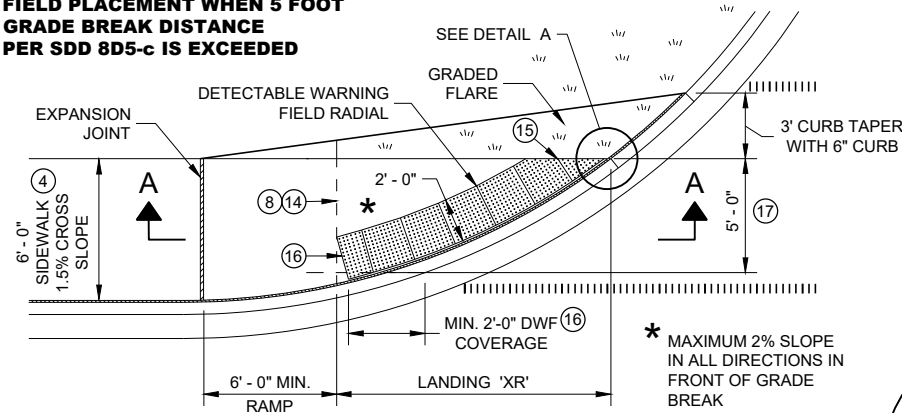

PLAN VIEW CURB RAMP TYPE 4A1 (GRADE BREAK DISTANCE GREATER THAN 5 FEET)

- LEGEND**
- 1/2" EXPANSION JOINT SIDEWALK
 - - - - - CONTRACTION JOINT SIDEWALK
 - ||||| PAVEMENT MARKING CROSSWALK (WHITE)

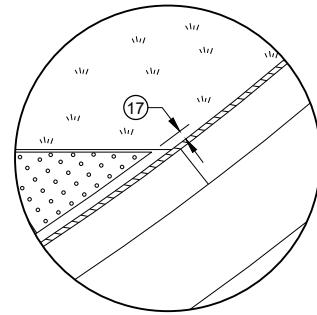

DETAIL A

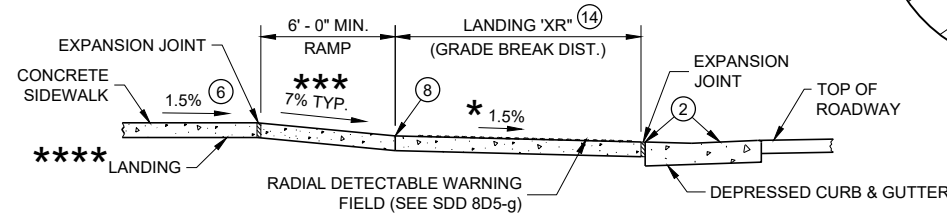

SECTION A - A FOR TYPE 4A1

**** IF RAMP SLOPE IS LESS THAN 5.0%, THEN NO ADJACENT UPHILL LANDING IS REQUIRED

*** MAXIMUM 8.33%

GENERAL NOTES

- AVOID PLACING DRAINAGE STRUCTURES, JUNCTION BOXES OR OTHER OBSTRUCTIONS IN FRONT OF RAMP ACCESS AREAS.
- DETAILS OF CONSTRUCTION, MATERIALS AND WORKMANSHIP NOT SHOWN ON THIS DRAWING SHALL CONFORM TO THE PERTINENT REQUIREMENTS OF THE STANDARD SPECIFICATIONS AND THE APPLICABLE SPECIAL PROVISIONS.
- DETECTABLE WARNING FIELDS THAT ARE INSTALLED AS A GROUP OR SIDE BY SIDE, SHALL BE FROM THE SAME MANUFACTURER.
- APPLY RADIAL DETECTABLE WARNING PLACEMENT SIMILARLY FOR TYPE 4A AND 4A1 CURB RAMPS AND SIMILARLY FOR TYPE 4B AND 4B1 CURB RAMPS. TYPE 4A AND 4B RAMPS ARE NOT SHOWN.
- REFER TO SDD 8D5-g FOR ADDITIONAL RADIAL PLATE REQUIREMENTS.
- FIELD CUTS AT INTERMEDIATE JOINTS WITHIN THE RADIAL DETECTABLE WARNING FILED ARE PROHIBITED.
- DETERMINE FINAL RADIAL WARNING FIELD CONFIGURATION AND ITS INDIVIDUAL PLATE LOCATIONS. PERFORM PRE-LAYOUT PRIOR TO PLACEMENT IN PLASTIC CONCRETE. FOLLOW MANUFACTURER'S PRODUCT LIST AND INSTALLATION RECOMMENDATIONS.
- 2 GRADE CHANGE BETWEEN GUTTER FLAG SLOPE AND THE CURB RAMP SLOPE SHALL NOT EXCEED 11%. MAXIMUM GUTTER FLAG SLOPE IS 4%. PROVIDE LONGITUDINAL DRAINAGE AROUND CURB AND AWAY FROM CURB RAMP. NO VERTICAL LIPS OR DISCONTINUITIES GREATER THAN 1/4 INCH ARE ALLOWED. SLOPE OF CURB HEAD OPENING SHALL MATCH THE RAMP SLOPE, MINIMALLY 1.5% AND NOT TO EXCEED 7%. WHEN ADJACENT TO 1.5% LANDING, CONSTRUCT CURB HEAD OPENING AT 1.5% IN THE DIRECTION OF PEDESTRIAN TRAVEL.
- 3 AN 8.33% CURB RAMP SLOPE IS ALLOWABLE WITH FLATTENED GUTTER FLAG SLOPE AND NOT TO EXCEED 11% GRADE CHANGE.
- 4 ±0.5% CONSTRUCTION TOLERANCE IN SIDEWALK CROSS SLOPE. THE SIDEWALK CROSS SLOPE SHALL NOT EXCEED 2% WITHOUT PRIOR APPROVAL FROM THE ENGINEER.
- 6 PROVIDE A LEVEL LANDING (MAXIMUM 2% SLOPE) IN ANY DIRECTION OF PEDESTRIAN TRAVEL. STANDARD LANDING SIZE IS 5 FEET BY 5 FEET.
- 8 PROVIDE GRADE BREAK PERPENDICULAR TO DIRECTION OF WHEELCHAIR TRAVEL.
- 14 CONSULT ENGINEER IF GRADE BREAK LOCATION (END OF LANDING DIMENSION "XR") REQUIRES FIELD ADJUSTMENT WHEN ESTABLISHING FINAL RADIAL DETECTABLE WARNING FIELD LOCATION.
- 15 FIELD SAW CUTS ALONG RADIAL DETECTABLE WARNING PLATES WILL BE NECESSARY TO MATCH EACH CURB RAMP EDGE. AVOID CUTTING THROUGH DOMES WHENEVER POSSIBLE. MAKE FIELD CUTS TRUE TO LINE AND WITHIN 1/8" DEVIATION. SMOOTH EDGES OF FIELD CUT PLATES.
- 16 USE 1' X 2" RECTANGULAR END PLATE AT END OF TYPE 4A1 RAMP AND PROVIDE MINIMUM 2' - 0" DETECTABLE WARNING FIELD COVERAGE (IN DIRECTION OF PEDESTRIAN TRAVEL) ALONG THE ENTIRE CURB RAMP WIDTH.
- 17 A MAXIMUM 3 INCH CONCRETE BORDER WITH IS ALLOWABLE IN FROM OF RADIAL DETECTABLE WARNING FIELD FOR CONSTRUCTABILITY PURPOSES. CONCRETE BORDER WIDTH MAY VARY UP TO 1 INCH.

RADIAL DETECTABLE WARNING FIELD PLACEMENT WHEN 5 FOOT GRADE BREAK DISTANCE PER SDD 8D5-d IS EXCEEDED

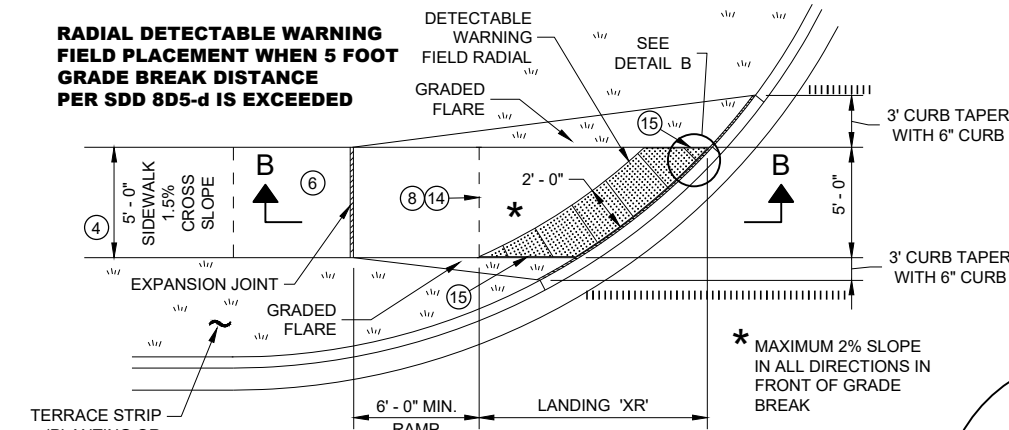

PLAN VIEW CURB RAMP TYPE 4B1 (GRADE BREAK DISTANCE GREATER THAN 5 FEET)

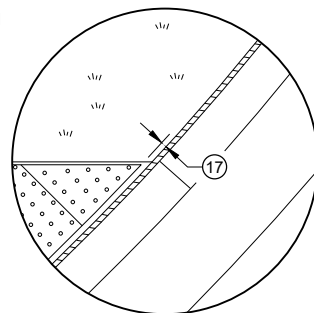

DETAIL B

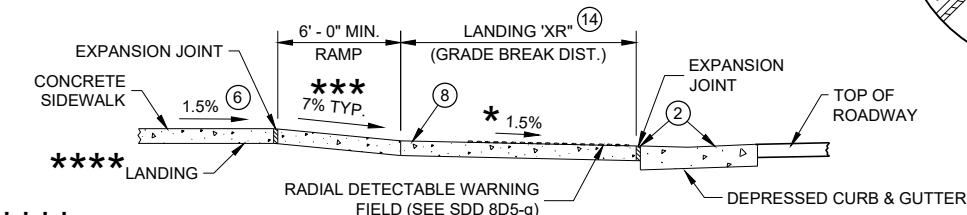

SECTION B - B FOR TYPE 4B1

**** IF RAMP SLOPE IS LESS THAN 5.0%, THEN NO ADJACENT UPHILL LANDING IS REQUIRED

*** MAXIMUM 8.33%

RADIAL DETECTABLE WARNING FIELD PLACEMENT WHEN 5 FOOT GRADE BREAK DISTANCE PER SDD 8D5-b IS EXCEEDED

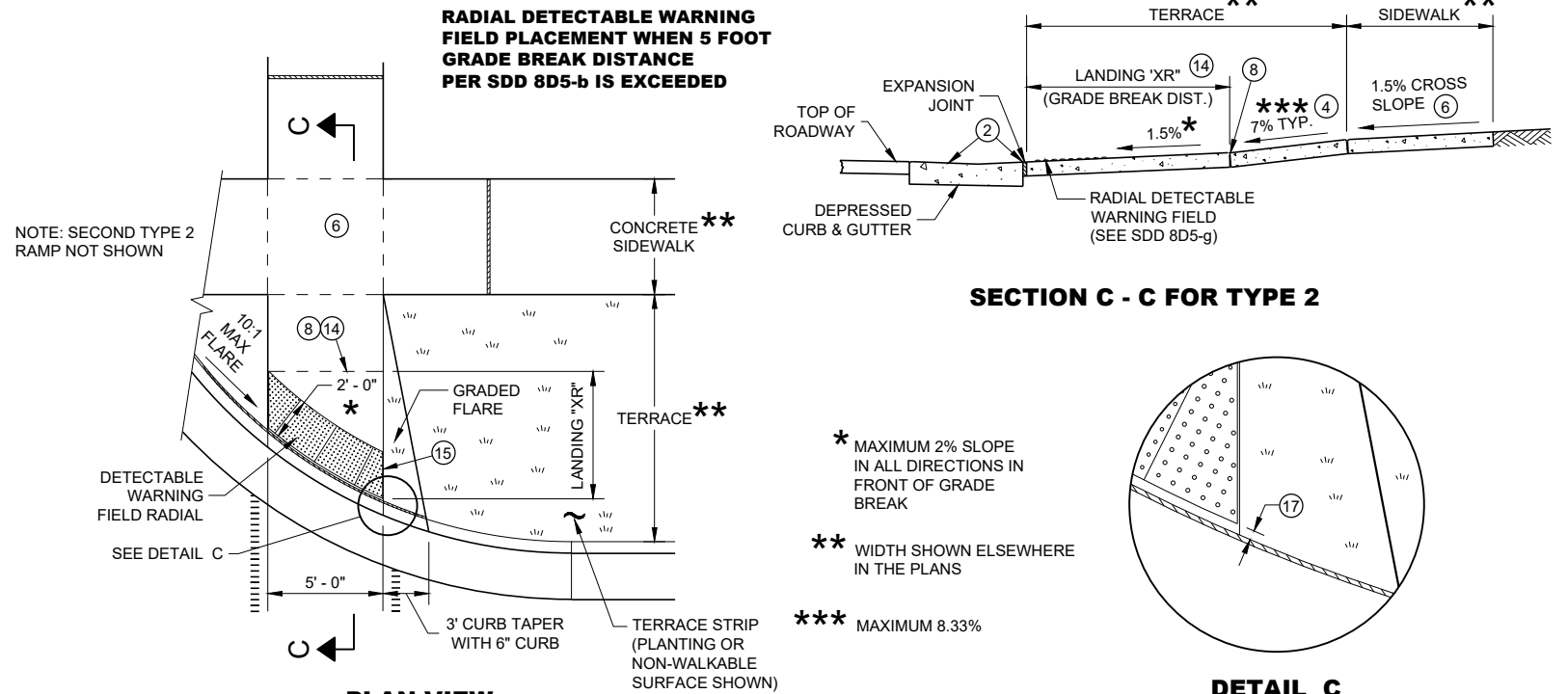

PLAN VIEW CURB RAMP TYPE 2 (GRADE BREAK DISTANCE GREATER THAN 5 FEET) (ON LINE WITH SIDEWALK)

NOTE: SECOND TYPE 2 RAMP NOT SHOWN

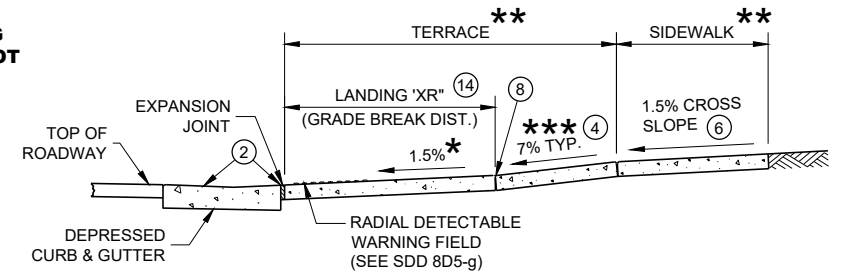

SECTION C - C FOR TYPE 2

* MAXIMUM 2% SLOPE IN ALL DIRECTIONS IN FRONT OF GRADE BREAK

** WIDTH SHOWN ELSEWHERE IN THE PLANS

*** MAXIMUM 8.33%

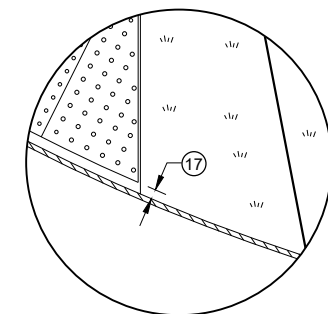

DETAIL C

CURB RAMPS RADIAL DETECTABLE WARNING FIELD APPLICATIONS

STATE OF WISCONSIN DEPARTMENT OF TRANSPORTATION

	MIN.	MAX.
A	1.6"	2.4"
B	0.65"	1.5"
C	*	*
D	0.9"	1.4"

* THE C DIMENSION IS 50% TO 65% OF THE D DIMENSION.

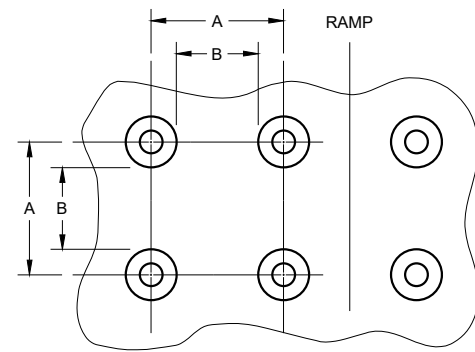

PLAN VIEW

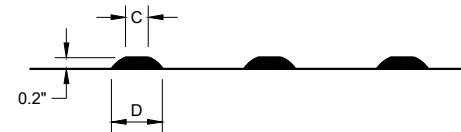

ELEVATION VIEW

**TRUNCATED DOMES
DETECTABLE WARNING PATTERN DETAIL**

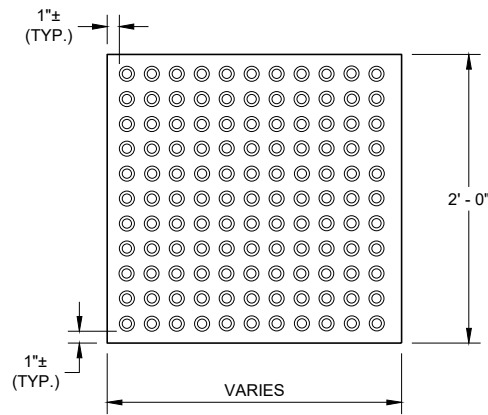

**RECTANGULAR
PLATES**

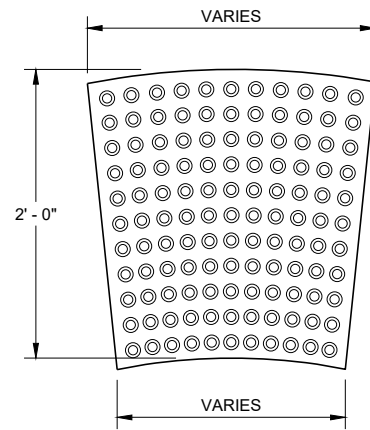

**RADIAL
PLATES**

**PLAN VIEW
DETECTABLE WARNING FIELDS (TYPICAL)**

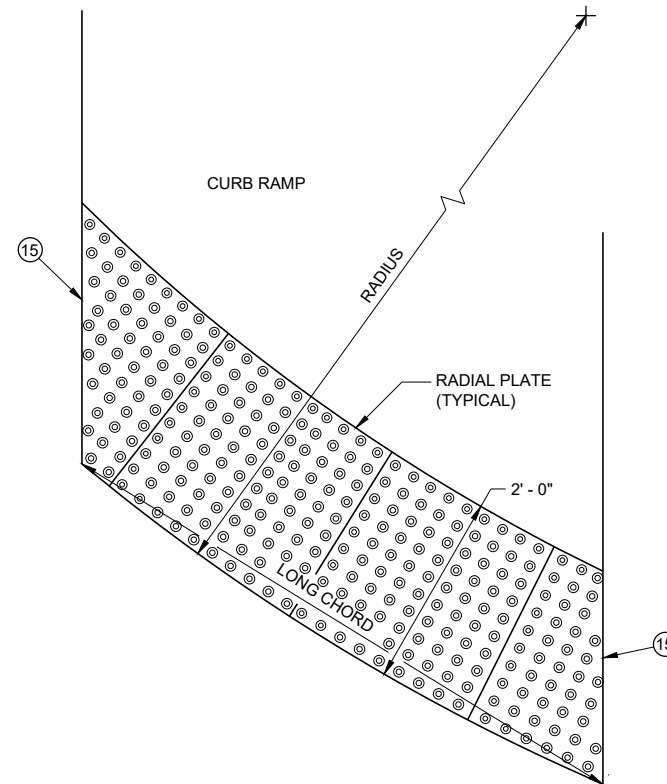

**PLAN VIEW
RADIAL DETECTABLE
WARNING FIELD ATTRIBUTES**

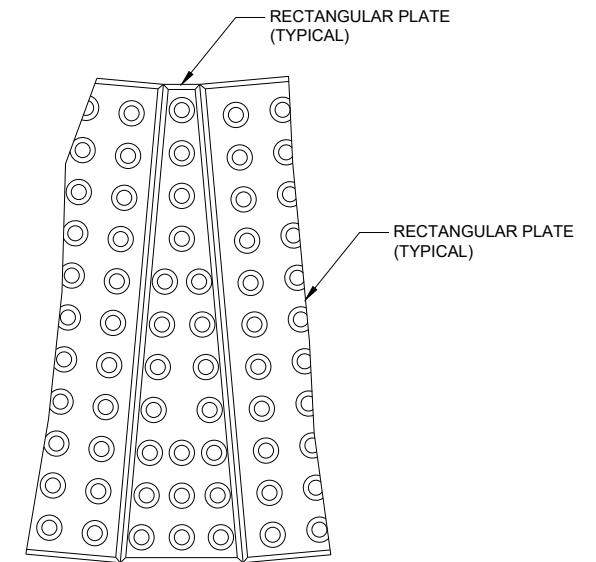

**PLAN VIEW
RADIAL WEDGE PLATE
CONNECTION DETAIL**

GENERAL NOTES

DETECTABLE WARNING FIELDS THAT ARE INSTALLED AT A CURB RAMP SHALL BE FROM THE SAME MANUFACTURER.

PLACE ALL DETECTABLE WARNING FIELD SYSTEMS IN ACCORDANCE TO THE MANUFACTURER'S RECOMMENDATION.

FIELD CUTS AT INTERMEDIATE JOINTS WITHIN THE RADIAL DETECTABLE WARNING FIELD ARE PROHIBITED.

DETERMINE FINAL RADIAL WARNING FIELD CONFIGURATION AND ITS INDIVIDUAL PLATE LOCATIONS. PERFORM PRE-LAYOUT PRIOR TO PLACEMENT IN PLASTIC CONCRETE. FOLLOW MANUFACTURER'S PRODUCT LIST AND INSTALLATION RECOMMENDATIONS.

FOR RADIAL DETECTABLE WARNING FIELD APPLICATIONS WHERE STANDARD RADIAL PLATES ARE NOT AVAILABLE AT AN INTERSECTION CURB RADIUS, A COMBINATION OF SQUARE OR RECTANGULAR PLATES AND RADIAL PLATES MAY BE USED TO FORM RADIAL CONFIGURATION. RADIAL WEDGE PLATES IN COMBINATION WITH SQUARE PLATES ARE ALSO ACCEPTABLE. FOLLOW MANUFACTURER'S RECOMMENDATIONS.

REFER TO CONTRACT AND STANDARD SPECIFICATIONS FOR FIELD CUTTING REQUIREMENTS.

DO NOT EMBED IN CONCRETE ANY FIELD-CUT PLATES WITH CUT EDGES SHORTER THAN 6 INCHES. CONSULT WITH MANUFACTURER FOR RE-DRILLING AND ANCHORING REQUIREMENTS OF FIELD-CUT PLATES.

15 FIELD SAW CUTS ALONG RADIAL DETECTABLE WARNING PLATES WILL BE NECESSARY TO MATCH EACH CURB RAMP EDGE. AVOID CUTTING THROUGH DOMES WHENEVER POSSIBLE. MAKE FIELD CUTS TRUE TO LINE AND WITHIN 1/8" DEVIATION. SMOOTH EDGES OF FIELD CUT PLATES.

**CURB RAMPS
RECTANGULAR AND RADIAL
DETECTABLE WARNING PLATES**

STATE OF WISCONSIN
DEPARTMENT OF TRANSPORTATION

APPROVED
May 2019 /S/ Rodney Taylor
DATE ROADWAY STANDARDS DEVELOPMENT
UNIT SUPERVISOR

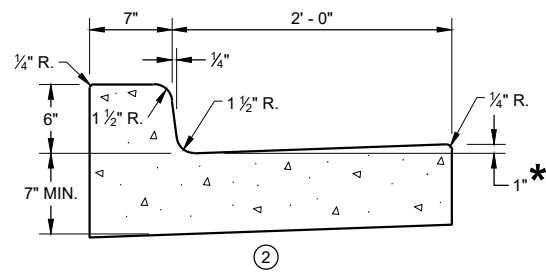

CONCRETE CURB AND GUTTER 31" ①

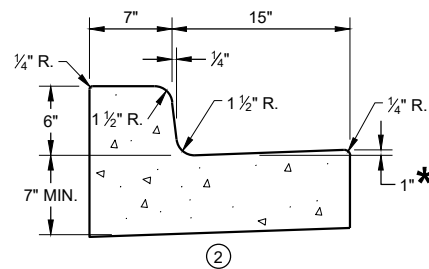

CONCRETE CURB AND GUTTER 22" ①

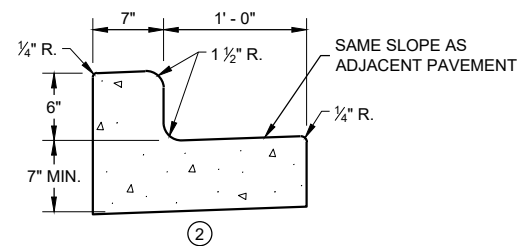

CONCRETE CURB AND GUTTER 19" ①

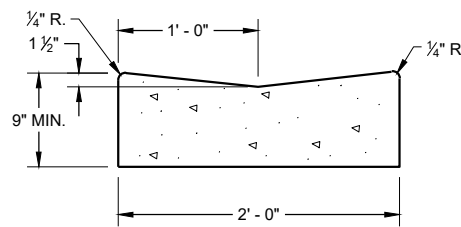

CONCRETE GUTTER 24" ①

* TO BE MEASURED TO A MAXIMUM OF 3" WHERE DRAINAGE PROBLEMS EXIST.

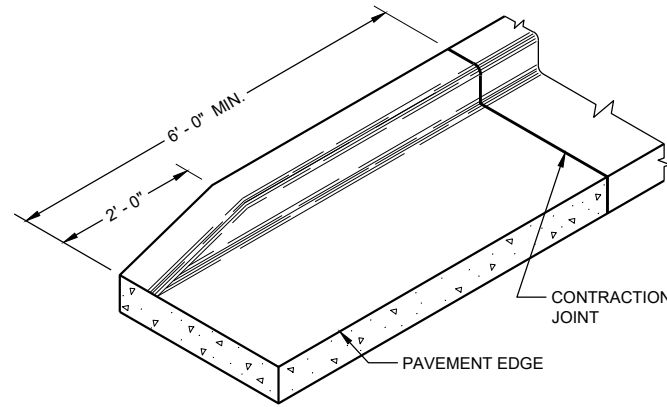

END SECTION CURB AND GUTTER

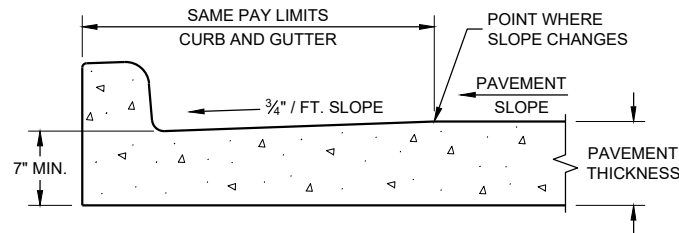

PARTIAL SECTION OF PAVEMENT WITH INTEGRAL CURB AND GUTTER

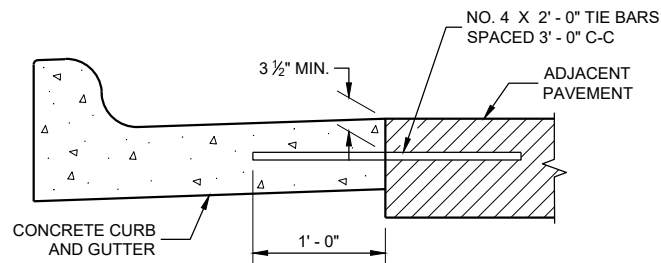

TYPICAL TIE BAR LOCATION ①

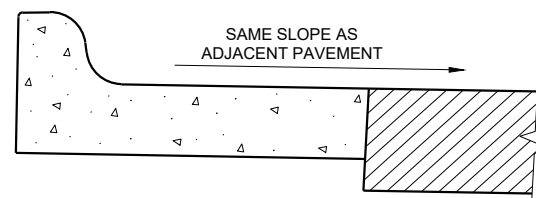

HIGH SIDE SECTION ③
(TYPICAL FOR ALL CURB & GUTTER TYPES)

GENERAL NOTES

DETAILS OF CONSTRUCTION AND WORKMANSHIP NOT SHOWN ON THIS DRAWING SHALL CONFORM TO THE PERTINENT REQUIREMENTS OF THE CONTRACT.

PAVEMENT TIES AND TIE BARS SHALL BE EPOXY COATED IN CONFORMANCE WITH SUBSECTION 505.2.6.2 OF THE STANDARD SPECIFICATIONS.

INTEGRAL CURB AND GUTTER SHALL CONFORM TO THE DETAILS SHOWN FOR CONCRETE CURB AND GUTTER INCLUDING THE TRANSVERSE GUTTER SLOPE. A LONGITUDINAL CONSTRUCTION JOINT IS NOT REQUIRED WITH INTEGRAL CURB AND GUTTER.

UNLESS OTHERWISE SHOWN ON THE TYPICAL CROSS SECTIONS, THE BASE COURSE AND UNCLASSIFIED EXCAVATION LIMITS ARE 2'-0" BEHIND THE BACK OF CURBS.

- ① WHEN PLACED ADJACENT TO NEW CONCRETE, TIE BARS ARE REQUIRED FOR CURB AND GUTTER 31", 22", 19" AND CONCRETE GUTTER 24".
- ② THE BOTTOM OF CURB AND GUTTER MAY BE CONSTRUCTED EITHER LEVEL OR PARALLEL TO THE SLOPE OF THE SUBGRADE OR BASE COURSE PROVIDED A 7" MINIMUM GUTTER THICKNESS IS MAINTAINED.
- ③ WHEN HIGH SIDE CURB SECTION IS REQUIRED, THE LOCATION(S) WILL BE NOTED ON THE PLANS

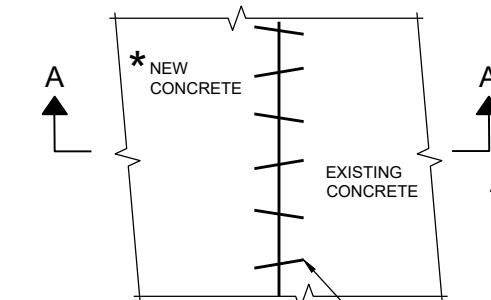

PLAN VIEW

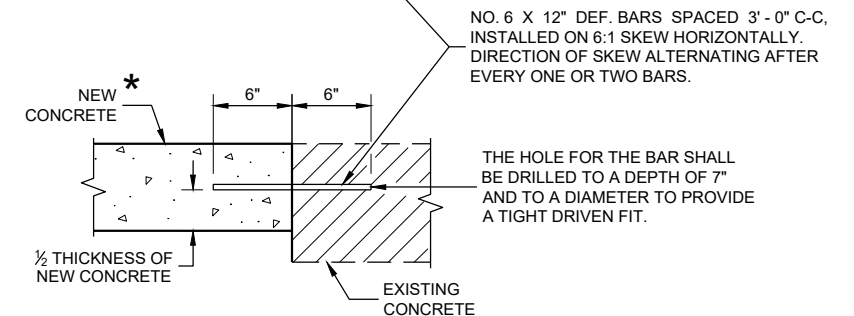

SECTION A - A

PAVEMENT TIES

CONCRETE GUTTER, CURB AND GUTTER AND PAVEMENT TIES (For Optional use in Milwaukee Co. Only)	
STATE OF WISCONSIN DEPARTMENT OF TRANSPORTATION	
APPROVED February 2020 DATE	/S/ Rodney Taylor ROADWAY STANDARDS DEVELOPMENT ENGINEER
FHWA	

INLET COVERS

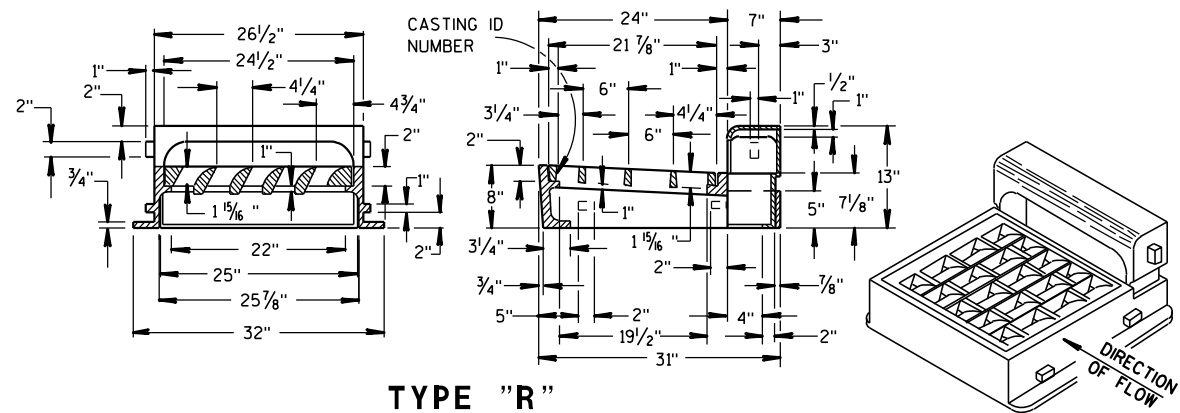

TYPE "R"

SHOWING SPECIAL GRATE NO. 1
(TO BE NOTED AS R-1 IN DRAINAGE TABLE)

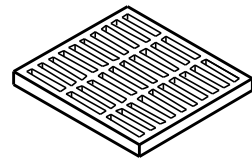
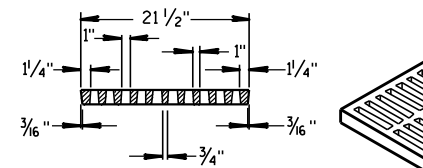

(APPROX. WEIGHT - 510 LBS.)
 FRAME..... 245 LBS.
 CURB..... 120 LBS.
 GRATE..... 145 LBS.

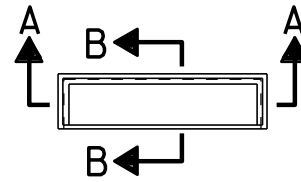

SECTION B-B SECTION A-A
SPECIAL CURB PLUG "P"
 (CURB PLUG..... 85 LBS.)
 (TO BE NOTED AS R-P IN DRAINAGE TABLE)

NOTE:
CURB PLUG USED IN PLACE
OF CURB BOX IN ABSENCE
OF CONC. CURB. FILL TO
TOP WITH CONCRETE.

GRATE FOR TYPE "R" INLET COVER

(GRATE..... 150 LBS.)
(TO BE USED UNLESS OTHERWISE NOTED IN DRAINAGE TABLE)

'H' = 9" FOR 6" CURB
'H' = 11" FOR 8" CURB
'G' = 13 3/4" FOR 6" CURB
'G' = 15 3/4" FOR 8" CURB

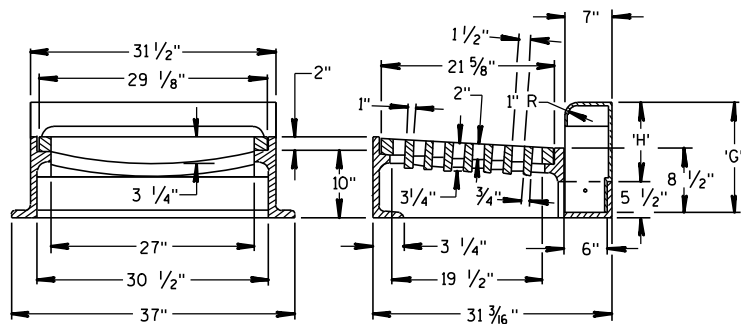

TYPE "W"

(APPROX. WEIGHT - 670 LBS.)
 FRAME..... 350 LBS.
 CURB BOX..... 135 LBS.
 GRATE..... 185 LBS.

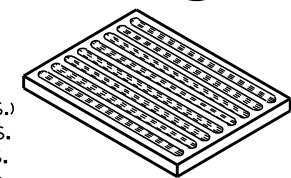
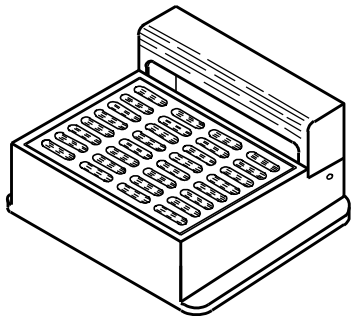

ALTERNATE GRATE
 (FOR EXPRESSWAY RAMPS)
TYPES "W" & "X"

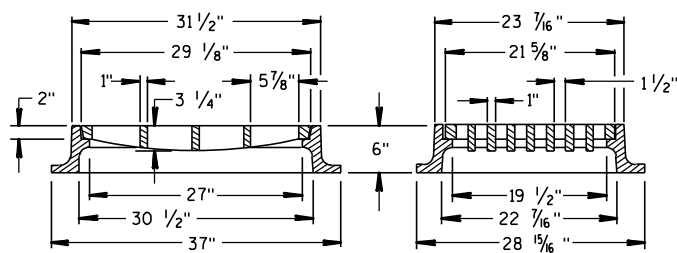

TYPE "X"

(APPROX. WEIGHT - 470 LBS.)

MANHOLE COVER

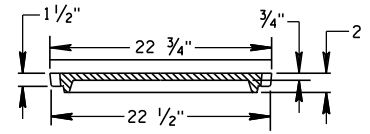

SECTION C-C

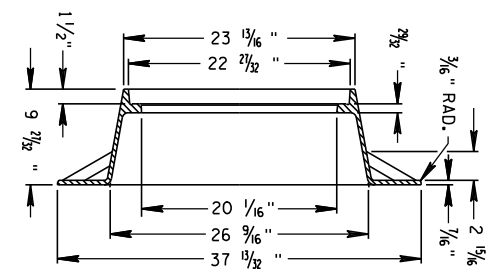
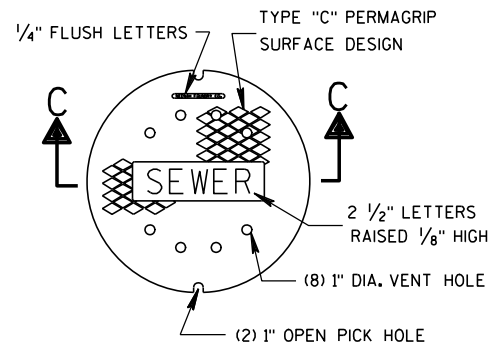

TYPE "Q"

(APPROX. WEIGHT - 290 LBS.)

TABLE OF DIMENSIONS

TYPE	'A'	'B'	'C'
11	3'-6"	2'-8"	12" - 36"*
12	4'-0"	3'-8"	12" - 42"***
13	5'-0"	5'-8"	42" - 48"
14	6'-0"	7'-8"	54" - 60"

* 12" - 21" FOR PRECAST MANHOLES
 *** 12" - 24" FOR PRECAST MANHOLES

THE FIRST STEP SHALL BE PLACED
16" ABOVE THE BENCH.

MANHOLE

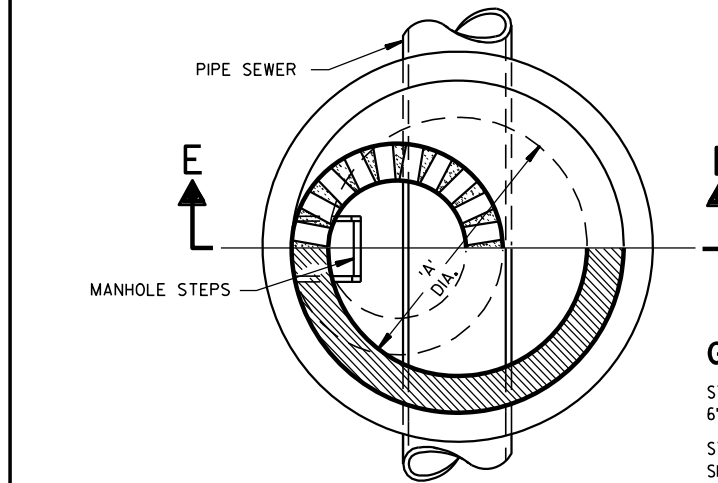

HALF SECTION D-D

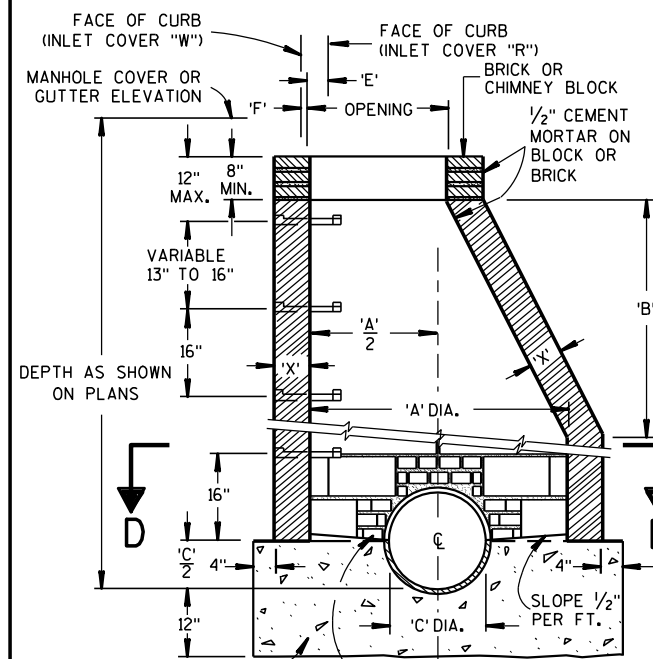

SECTION E-E

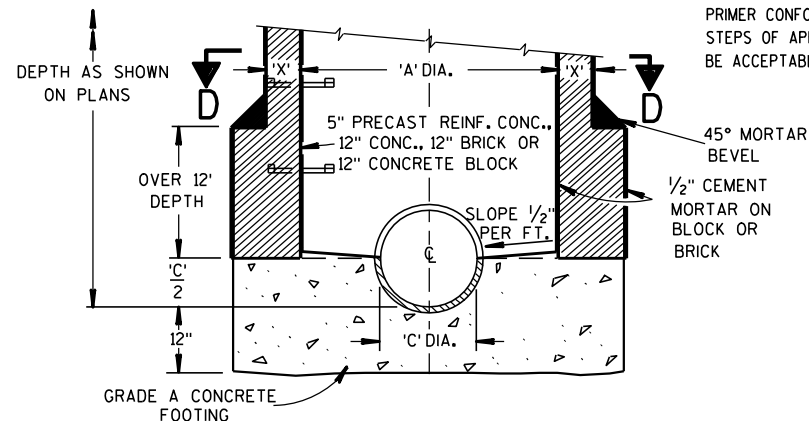

SECTION E-E

TYPES 11, 12, 13 & 14

TABLE OF OPENING DIMENSIONS

COVER TYPE	DESCRIPTION	OPENING	'E'	'F'
"O"	ROUND	2'-2" DIA.	—	—
"W"	CURB BOX	1'-8" X 2'-6"	—	1"
"X"	INLET	1'-10" X 2'-6"	—	—
"R"	CURB BOX	2'-0" X 2'-1"	4"	—

GENERAL NOTES

STRUCTURE WALL THICKNESS 'X' TO BE 8" BRICK, 6" CONCRETE BLOCK, 6" GRADE A CONCRETE OR 5" PRECAST REINFORCED CONCRETE.

STRUCTURE FOOTINGS ARE TO BE GRADE A CONCRETE OF THE THICKNESS SHOWN IN THE DETAIL OR 5" PRECAST REINFORCED CONCRETE.

REINFORCEMENT FOR 5" PRECAST REINFORCED CONCRETE SHALL BE 6" X 6" W16 X W16 WELDED SREEL WIRE FABRIC AND SHALL BE EMBEDDED 2" CLEAR.

PRECAST INLET UNITS AND BASES SHALL CONFORM TO THE PERTINENT REQUIREMENTS OF AASHTO DESIGNATION M 199.

PRECAST CONCRETE FLAT SLAB TOPS MAY BE USED ON THE STRUCTURES. THE TOPS SHALL BE INSTALLED ON A BED OF MORTAR.

PRECAST REINFORCED BASES SHALL BE PLACED ON A BED OF MATERIAL AT LEAST 6" IN DEPTH, WHICH MEETS THE REQUIREMENTS FOR GRANULAR BACK-FILL. THIS BEDDING SHALL BE COMPACTED AND PROVIDE UNIFORM SUPPORT FOR THE ENTIRE AREA OF THE BASE.

SET FRAME ELEVATION 0.03 FT. LOWER THAN ELEVATION INDICATED ON THE PLANS.

THE CONTRACTOR MAY FORM AND POUR MONOLITHIC CONCRETE INVERT PROVIDED THE PIPE ENDS ARE EXTENDED INTO THE M.H. AND NOT TERMINATED WITHIN THE M.H. WALLS.

MANHOLE STEPS

STEPS MEETING THE FOLLOWING REQUIREMENTS SHALL BE INSTALLED IN ALL STRUCTURES OVER 5 FEET IN DEPTH; 16 INCH C-C MAX. SPACING; PROJECT A MINIMUM CLEAR DISTANCE OF 4 INCHES FROM THE WALL AT THE POINT OF EMBEDMENT; MINIMUM WALL EMBEDMENT OF 3 INCHES IN PRECAST MANHOLE AND 6 INCHES IN 8 INCH BRICK OR 6 INCH BLOCK MANHOLE; TREAD OF STEP SHALL HAVE A NON-SKID SURFACE AND BE FLANKED BY CLEATS, WITH A MINIMUM OF 10 INCHES CLEAR BETWEEN CLEATS, TO PREVENT FOOT SLIPPING OFF THE EDGE CLEATS SHALL BE A MINIMUM OF 3/4 INCH HIGH BY 3/4 INCH WIDE HAVING A MINIMUM THICKNESS OF 3/8 INCH. STEPS SHALL BE CAPABLE OF SUPPORTING A CONCENTRATED LOAD OF 300 LBS. FERROUS METAL STEPS NOT PAINTED OR TREATED TO RESIST CORROSION SHALL HAVE A MINIMUM CROSS SECTIONAL DIMENSION OF 1 INCH.

SOLID ALUMINUM STEPS SHALL HAVE A MINIMUM CROSS SECTIONAL DIMENSION OF 0.75 INCH. ALUMINUM SURFACES TO BE EMBEDDED IN CONCRETE SHALL BE GIVEN ONE COAT OF SUITABLE QUALITY PAINT, SUCH AS ZINC CHROMATE PRIMER CONFORMING TO FEDERAL SPECIFICATION TT-P-645 OR EQUIVALENT. STEPS OF APPROVED POLYPROPYLENE PLASTIC COATED REINFORCING BAR WILL BE ACCEPTABLE.

MANHOLES, MANHOLE & INLET COVERS

STATE OF WISCONSIN
DEPARTMENT OF TRANSPORTATION

APPROVED
4/12/2011 DATE /S/ Jerry H. Zogg
ROADSIDE STANDARDS DEVELOPMENT ENGINEER
FHWA

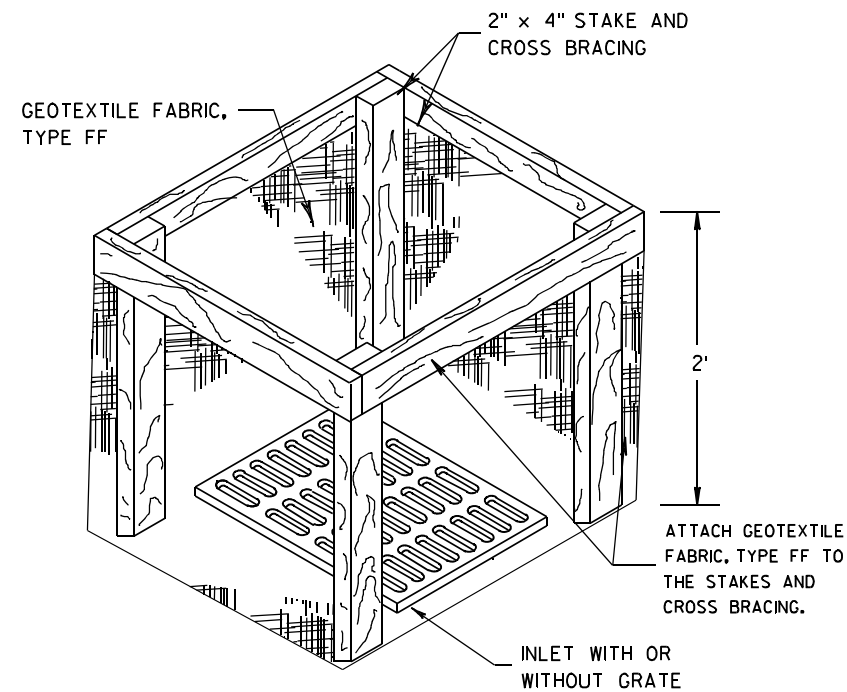
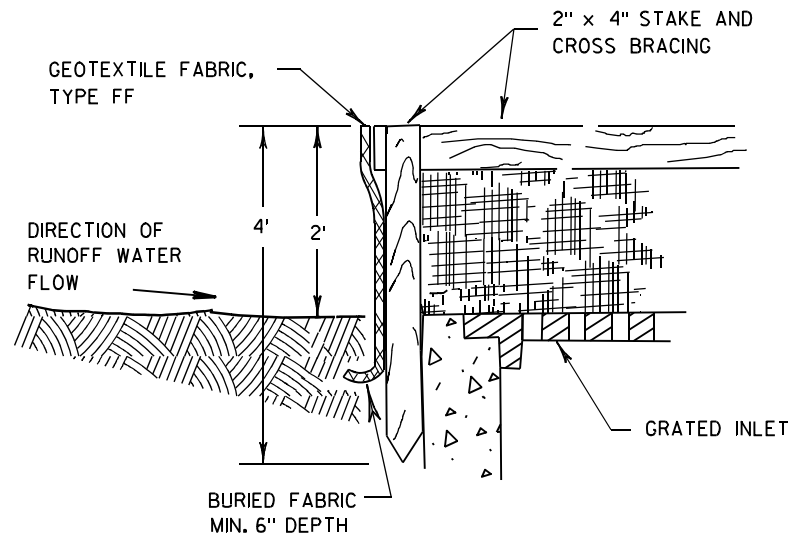

INLET PROTECTION, TYPE A

GENERAL NOTES

INLET PROTECTION DEVICES SHALL BE MAINTAINED OR REPLACED AT THE DIRECTION OF THE ENGINEER.

MANUFACTURED ALTERNATIVES APPROVED AND LISTED ON THE DEPARTMENT'S EROSION CONTROL PRODUCT ACCEPTABILITY LIST MAY BE SUBSTITUTED.

WHEN REMOVING OR MAINTAINING INLET PROTECTION, CARE SHALL BE TAKEN SO THAT THE SEDIMENT TRAPPED ON THE GEOTEXTILE FABRIC DOES NOT FALL INTO THE INLET. ANY MATERIAL FALLING INTO THE INLET SHALL BE REMOVED IMMEDIATELY.

- ① FINISHED SIZE, INCLUDING FLAP POCKETS WHERE REQUIRED, SHALL EXTEND A MINIMUM OF 10" AROUND THE PERIMETER TO FACILITATE MAINTENANCE OR REMOVAL.
- ② FOR INLET PROTECTION, TYPE C (WITH CURB BOX), AN ADDITIONAL 18" OF FABRIC IS WRAPPED AROUND THE WOOD AND SECURED WITH STAPLES. THE WOOD SHALL NOT BLOCK THE ENTIRE HEIGHT OF THE CURB BOX OPENING.
- ③ FLAP POCKETS SHALL BE LARGE ENOUGH TO ACCEPT WOOD 2X4.

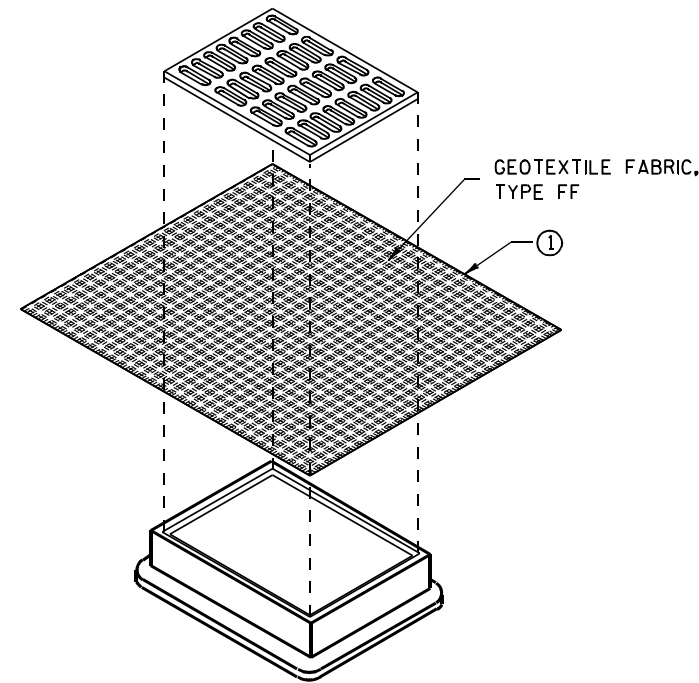

**INLET PROTECTION, TYPE B
(WITHOUT CURB BOX)**

(CAN BE INSTALLED IN ANY INLET WITHOUT A CURB BOX)

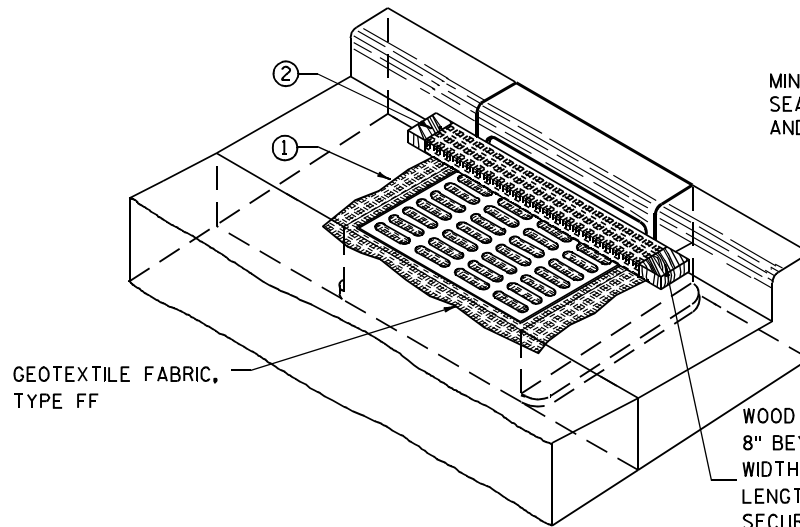

INLET PROTECTION, TYPE C (WITH CURB BOX)

INSTALLATION NOTES

TYPE B & C

TRIM EXCESS FABRIC IN THE FLOW LINE TO WITHIN 3" OF THE GRATE.

THE CONTRACTOR SHALL DEMONSTRATE A METHOD OF MAINTENANCE, USING A SEWN FLAP, HAND HOLDS OR OTHER METHOD TO PREVENT ACCUMULATED SEDIMENT FROM ENTERING THE INLET.

TYPE D

DO NOT INSTALL INLET PROTECTION TYPE D IN INLETS SHALLOWER THAN 30", MEASURED FROM THE BOTTOM OF THE INLET TO THE TOP OF THE GRATE.

TRIM EXCESS FABRIC IN THE FLOW LINE TO WITHIN 3" OF THE GRATE.

THE INSTALLED BAG SHALL HAVE A MINIMUM SIDE CLEARANCE, BETWEEN THE INLET WALLS AND THE BAG, MEASURED AT THE BOTTOM OF THE OVERFLOW HOLES, OF 3". WHERE NECESSARY THE CONTRACTOR SHALL CINCH THE BAG, USING PLASTIC ZIP TIES, TO ACHIEVE THE 3" CLEARANCE. THE TIES SHALL BE PLACED AT A MAXIMUM OF 4" FROM THE BOTTOM OF THE BAG.

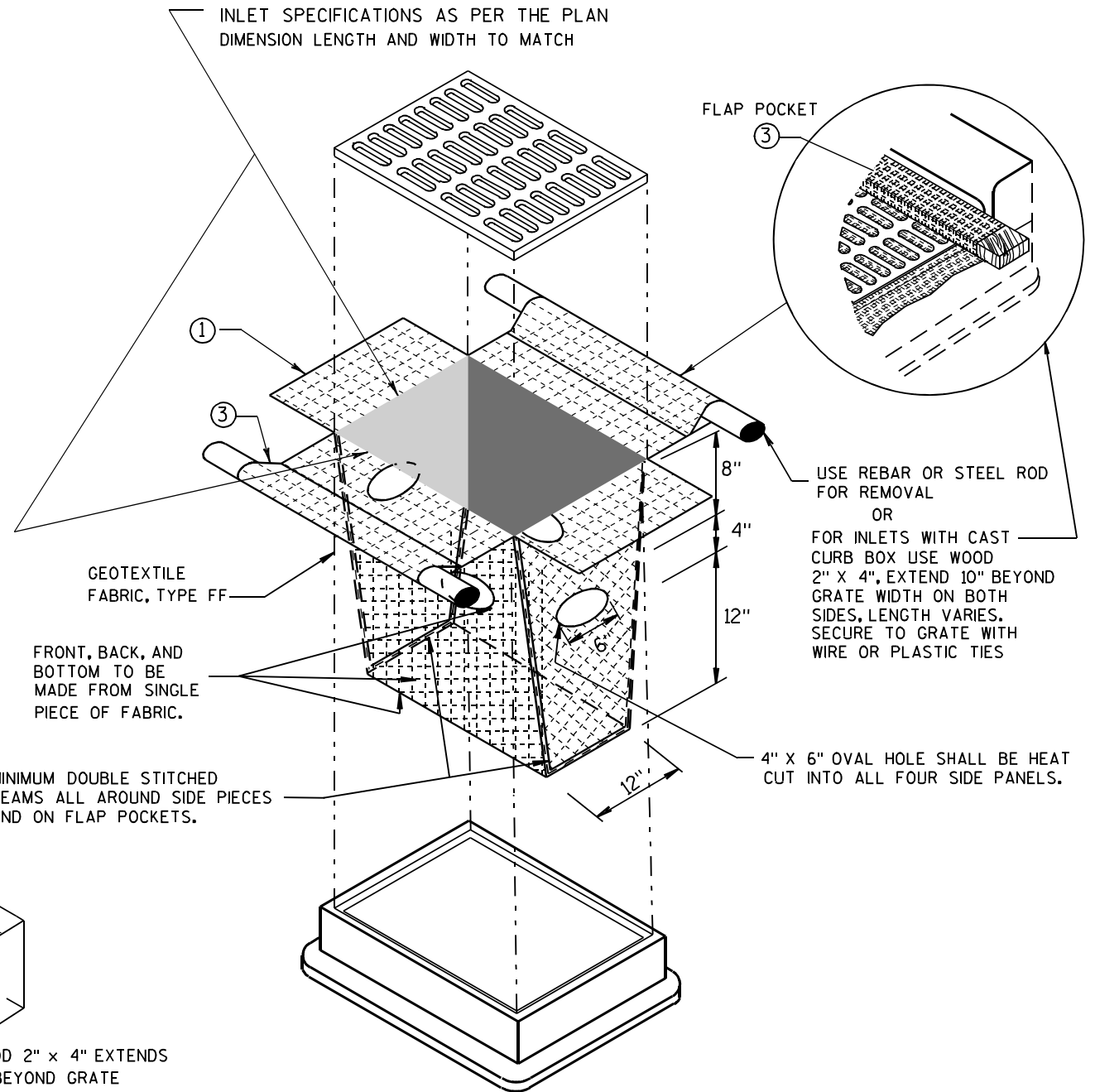

INLET PROTECTION, TYPE D

(CAN BE INSTALLED IN ANY INLET TYPE WITH OR WITHOUT A CURB BOX AS PER NOTE ②)

INLET PROTECTION TYPE A, B, C, AND D	
STATE OF WISCONSIN DEPARTMENT OF TRANSPORTATION	
APPROVED 10/16/02 DATE	/S/ Beth Connestra CHIEF ROADWAY DEVELOPMENT ENGINEER
FHWA	

GENERAL NOTES

DETAILS OF CONSTRUCTION, MATERIALS AND WORKMANSHIP NOT SHOWN ON THIS DRAWING SHALL CONFORM TO THE PERTINENT REQUIREMENTS OF THE STANDARD SPECIFICATIONS AND THE APPLICABLE SPECIAL PROVISIONS.

TRACKING PAD SHALL BE INSPECTED DAILY. DEFICIENT AREAS SHALL BE REPAIRED OR REPLACED IMMEDIATELY.

TRACKING PAD TO BE REMOVED AFTER CONSTRUCTION IS COMPLETED.

TRACKING PAD SHALL BE THE FULL WIDTH OF THE EGRESS POINT.

SURFACE WATER MUST BE PREVENTED FROM PASSING THROUGH THE TRACKING PAD. FLOWS SHALL BE DIVERTED AWAY, AROUND OR CONVEYED UNDER THE TRACKING PAD.

CULVERT PIPE OR OTHER BMP USED TO DIVERT WATER AWAY, AROUND OR UNDER THE TRACKING PAD SHALL BE DESIGNED TO CONVEY THE 2 YEAR - 24 HOUR EVENT.

THE COST OF ADDITIONAL BMP TO DIVERT WATER ARE INCIDENTAL TO THE TRACKING PAD BID ITEM.

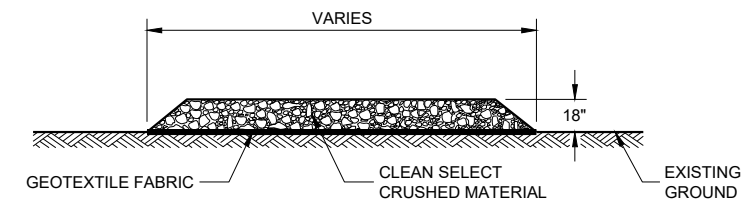

SECTION A - A

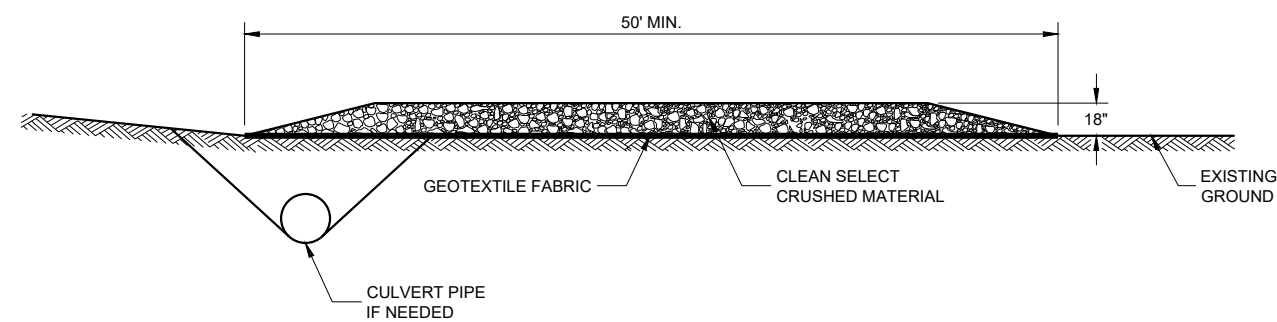
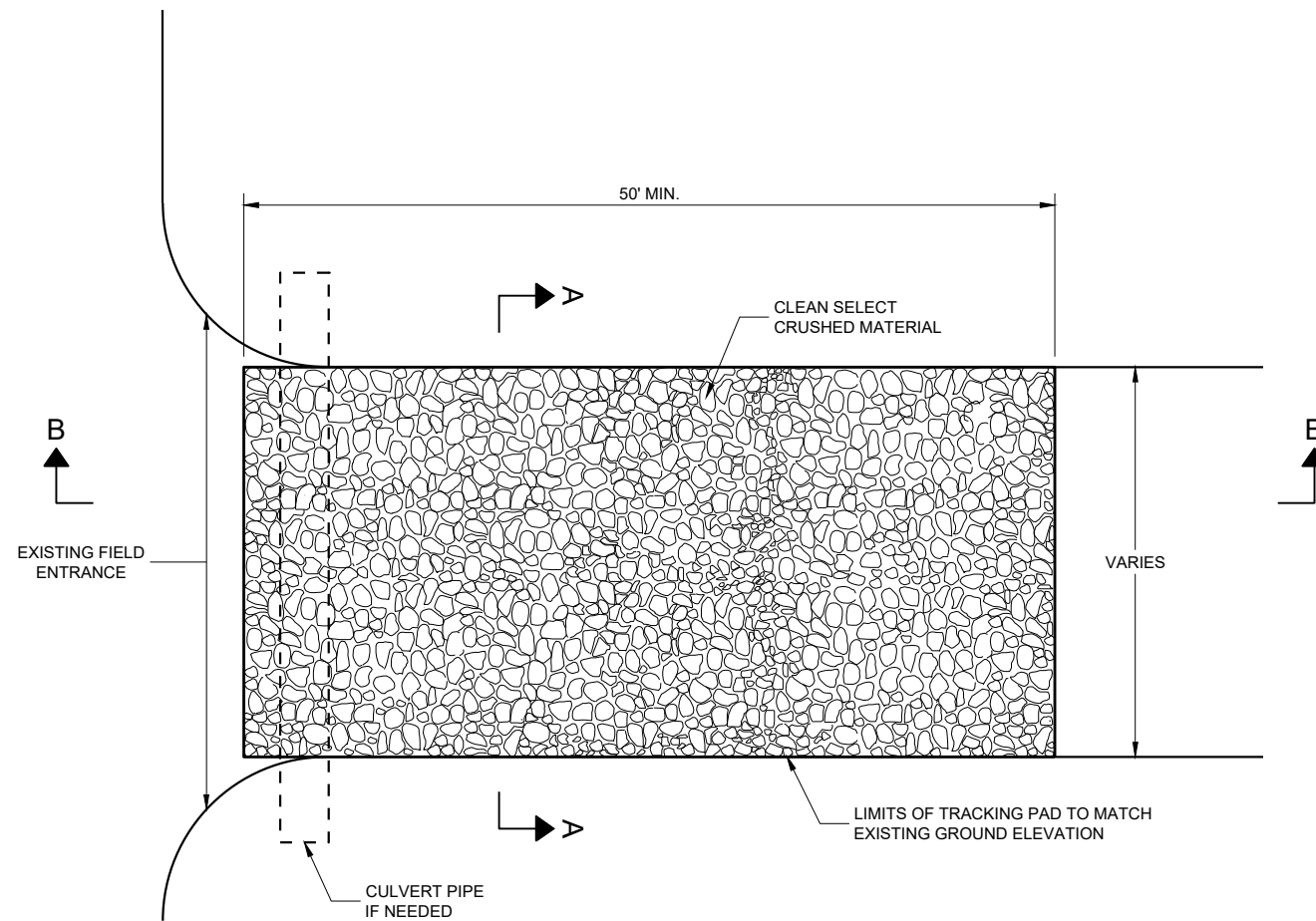

SECTION B - B

TRACKING PAD

STATE OF WISCONSIN
DEPARTMENT OF TRANSPORTATION

APPROVED
3/24/2011 DATE /S/ Jerry H. Zogg
ROADWAY STANDARDS DEVELOPMENT ENGINEER

FHWA

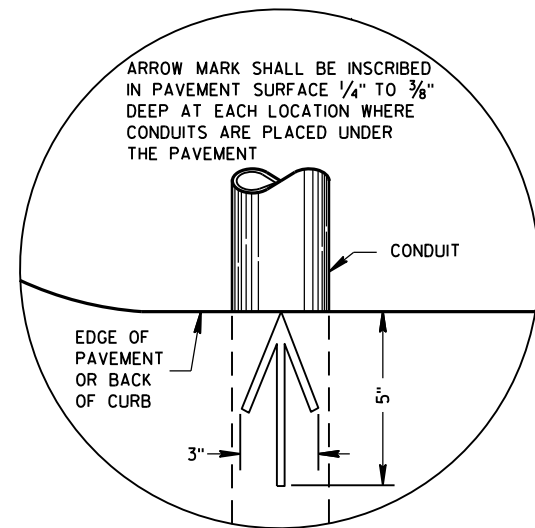

PLAN VIEW
ARROW MARK

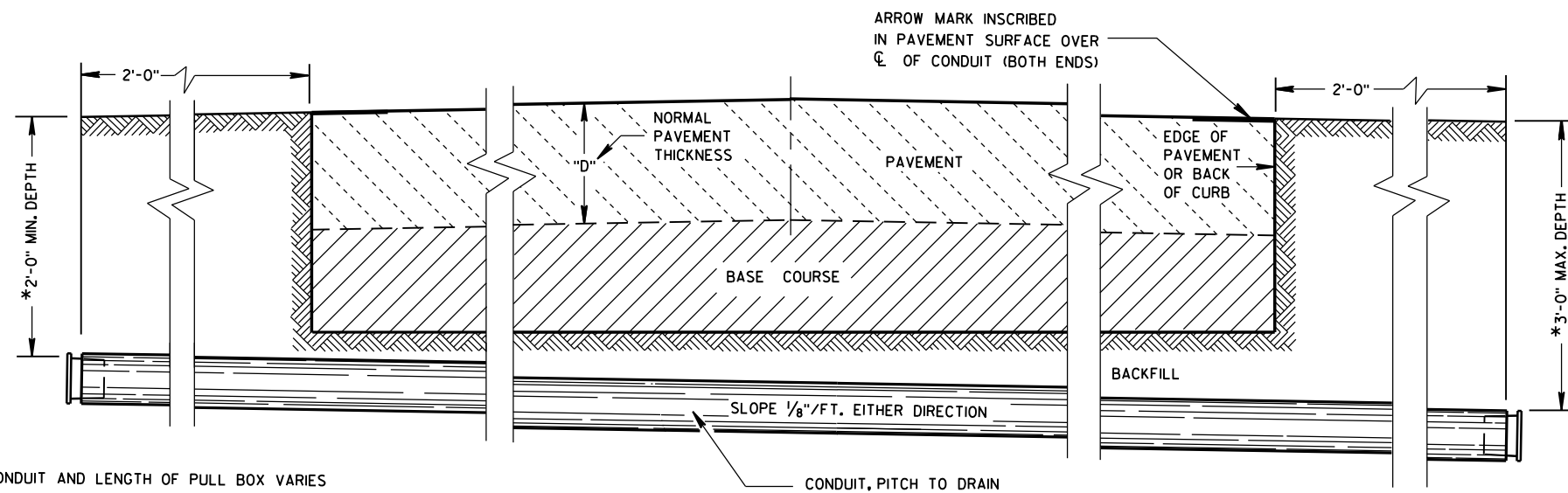

SIDE ELEVATION
DETAIL FOR CONDUIT UNDER PAVED HIGHWAYS

*DEPTH OF CONDUIT AND LENGTH OF PULL BOX VARIES WITH HEIGHT OF CURB USED. ALSO SEE PULL BOX S.D.D. 9B4

GENERAL NOTES

DETAILS OF CONSTRUCTION, MATERIALS AND WORKMANSHIP NOT SHOWN ON THIS DRAWING SHALL CONFORM TO THE PERTINENT REQUIREMENTS OF THE CONTRACT.

METALLIC (STANDARD SPECIFICATION 652.2.2) OR NONMETALLIC (STANDARD SPECIFICATION 652.2.3) CONDUIT SHALL BE FURNISHED AND PLACED AS SHOWN.

DEPTH OF CONDUIT INSTALLED BELOW THE TRAVELED WAY SHALL BE 24 INCHES MINIMUM AND 36 INCHES MAXIMUM.

DEPTH OF CONDUIT INSTALLED THAT IS NOT BELOW THE TRAVELED WAY SHALL BE 18 INCHES MINIMUM AND 36 INCHES MAXIMUM.

ANY EXCEPTION TO THE MAXIMUM DEPTH SHALL BE ONLY WITH THE WRITTEN APPROVAL OF THE ENGINEER.

THE TRENCH SHALL NOT BE BACKFILLED PRIOR TO INSPECTION OF THE CONDUIT.

ALL METALLIC CONDUIT RACEWAY ENDS SHALL BE REAMED AND THREADED.

ALL METALLIC CONDUIT IN WHICH WIRE OR CABLE IS TO BE INSTALLED SHALL BE BUSHED WITH APPROVED THREADED BUSHINGS BEFORE INSTALLATION OF THE WIRE OR CABLE.

ALL METALLIC CONDUITS IN WHICH WIRE OR CABLE IS NOT TO BE INSTALLED SHALL BE CAPPED WITH THREADED PROTECTIVE CAPS, AS APPROVED BY THE ENGINEER.

ALL NONMETALLIC CONDUIT SHALL BE CAPPED OR PLUGGED IMMEDIATELY AFTER INSTALLATION AND SHALL REMAIN CAPPED OR PLUGGED UNTIL WIRE/CABLES ARE INSTALLED.

NONMETALLIC CONDUITS IN WHICH WIRE OR CABLE IS NOT BEING INSTALLED SHALL REMAIN CAPPED OR PLUGGED.

BENDING OF PVC ELECTRICAL CONDUIT SHALL BE ACCOMPLISHED BY USING A BLANKET OR EMERSON TYPE TANK DESIGNED FOR THE PURPOSE OF BENDING PVC ELECTRICAL CONDUIT.

ALL CUT ENDS SHALL BE TRIMMED INSIDE AND OUTSIDE TO REMOVE ALL ROUGH EDGES ON NONMETALLIC CONDUIT. (SEE NEC 347.5)

WHEN REQUIRED TO CONNECT NONMETALLIC CONDUIT TO METALLIC CONDUIT, ONLY U.L. LISTED ADAPTER FITTINGS SHALL BE USED.

PRIOR TO CONDUIT ACCEPTANCE, CONDUIT CAPS OR PLUGS SHALL BE REMOVED, AND THE CAPS, PLUGS AND CONDUIT ENDS SHALL BE THOROUGHLY CLEANED AND THEN THE CAPS OR PLUGS REINSTALLED TO ENSURE THAT THE CAPS OR PLUGS CAN BE EASILY REMOVED IN THE FUTURE.

ALL CONDUIT BEING FURNISHED AND INSTALLED SHALL HAVE THE U.L. LABEL FIRMLY ATTACHED.

CONDUIT RUNS SHALL BE THE SAME SIZE OF CONDUIT FROM ONE END TO THE OTHER (FROM PULL BOX TO PULL BOX-OR-JUNCTION BOX TO JUNCTION BOX-OR-BASE TO BASE, ETC.).

TRACER WIRE SHALL BE INSTALLED AS STATED IN THE STANDARD SPECIFICATION, ITEM 652.3.1.1.

ALL CONDUIT RUNS SHALL BE STRAIGHT (WITHOUT BENDS) FROM PULL BOX TO PULL BOX, PULL BOX TO BASE AND BASE TO BASE AS SHOWN ON THE PLANS.

6

6

S.D.D. 9 B 2-10

S.D.D. 9 B 2-10

CONDUIT	
STATE OF WISCONSIN DEPARTMENT OF TRANSPORTATION	
APPROVED March, 2017 DATE	/S/ Ahmet Demirbilek STATE ELECTRICAL ENGINEER
FHWA	

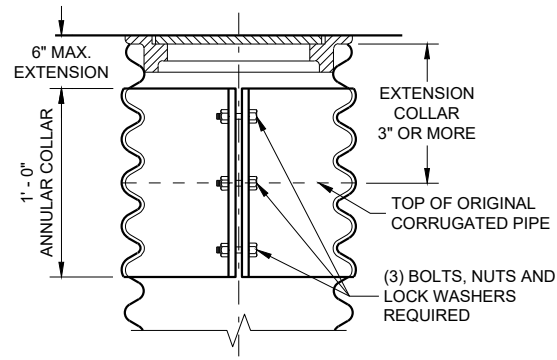

CORRUGATED PIPE EXTENDER

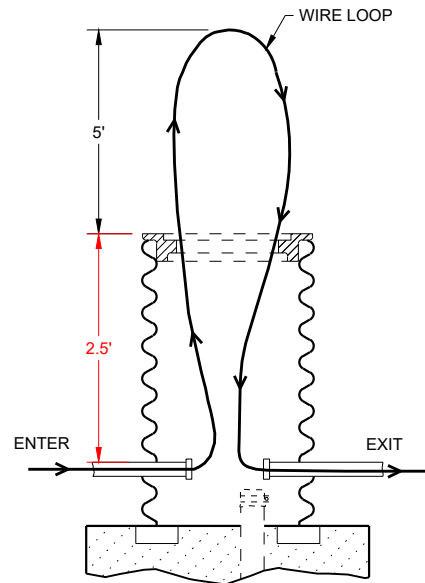

MEASUREMENT DETAIL FOR WIRE/CABLE IN THE PULL BOX

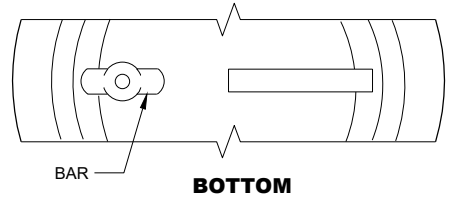

BOTTOM

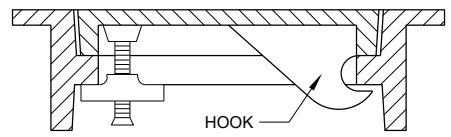

SECTION

**ALTERNATE COVER (LOCKING)
TIGHTENING BAR TYPE**

GENERAL NOTES

DETAILS OF CONSTRUCTION, MATERIALS AND WORKMANSHIP NOT SHOWN ON THIS DRAWING SHALL CONFORM TO THE PERTINENT REQUIREMENTS OF THE CONTRACT.

ALL FRAMES AND COVERS SHALL BE HEAVY DUTY TYPE, SUITABLE FOR VEHICULAR TRAFFIC LOADS.

PULL BOXES LOCATED IN THE ROADWAYS SHALL HAVE LOCKING COVERS.

ENTRANCE HOLES INTO PULL BOXES SHALL BE CUT WITH A CIRCULAR HOLE SAW OR HYDRAULIC CONDUIT PUNCH. HOLE SIZE SHALL BE THE OUTSIDE DIAMETER OF THE CONDUIT THAT IS TO FIT IN THE OPENING PLUS NO MORE THAN 1/4".

THE CONTRACTOR SHALL NOT INSTALL WIRE IN ANY PULL BOX UNTIL ITS INSTALLATION HAS BEEN INSPECTED AND ACCEPTED BY THE ENGINEER.

GROUNDING LUGS (MECHANICAL CONNECTORS) SHALL BE U.L. LISTED AND APPROVED FOR USE WITH COPPER WIRE.

ALL METALLIC CONDUIT IN WHICH WIRE AND/OR CABLE IS TO BE INSTALLED, SHALL BE BUSHED BEFORE INSTALLATION OF THE WIRE AND/OR CABLE.

WHEN PULL BOXES ARE INSTALLED FOR FUTURE USE, DO NOT INSTALL THE EQUIPMENT GROUNDING LUG. THE EQUIPMENT GROUNDING LUG, THE EQUIPMENT GROUNDING ELECTRODE AND THE EQUIPMENT GROUNDING CONDUCTOR SHALL BE REQUIRED AND INSTALLED UNDER A FUTURE WIRING CONTRACT.

TABLE OF NOMINAL DIMENSIONS AND WEIGHTS

DIMENSION IN INCHES		CORRUGATED STEEL PIPE								
PIPE DIAMETER (INSIDE)	A	12	12	12	18	18	18	24	24	24
PIPE LENGTH**	B	24	30	36	24	30	36	36	42	48
WALL THICKNESS	C	0.064	0.064	0.064	0.064	0.064	0.064	0.064	0.064	0.064
COVER	D	10 1/4	10 1/4	10 1/4	16 1/4	16 1/4	16 1/4	22 1/4	22 1/4	22 1/4
FRAME	E	14 1/2	14 1/2	14 1/2	20 1/2	20 1/2	20 1/2	26 1/2	26 1/2	26 1/2
FRAME	F	8 1/2	8 1/2	8 1/2	14 1/2	14 1/2	14 1/2	20 1/2	20 1/2	20 1/2
FRAME	G	11 1/2	11 1/2	11 1/2	17 1/2	17 1/2	17 1/2	23 1/2	23 1/2	23 1/2
		WEIGHT IN POUNDS*								
FRAME AND COVER		60	60	60	110	110	110	155	155	155

* THE ACTUAL WEIGHT OF THE MANHOLE FRAME AND COVER MAY VARY WITHIN 5 PERCENT PLUS OR MINUS OF THE WEIGHTS SHOWN.

** NORMALLY USED LENGTHS. THE PROJECT ENGINEER SHALL DETERMINE IF PIPE LENGTHS, OTHER THAN THOSE SPECIFIED, SHALL BE USED, TO A MAXIMUM OF 48" (CONTINUOUS LENGTH, NON-SPLICED). THE ADDITIONAL LENGTH SHALL BE INCIDENTAL TO THE PULL BOX BID PRICE.

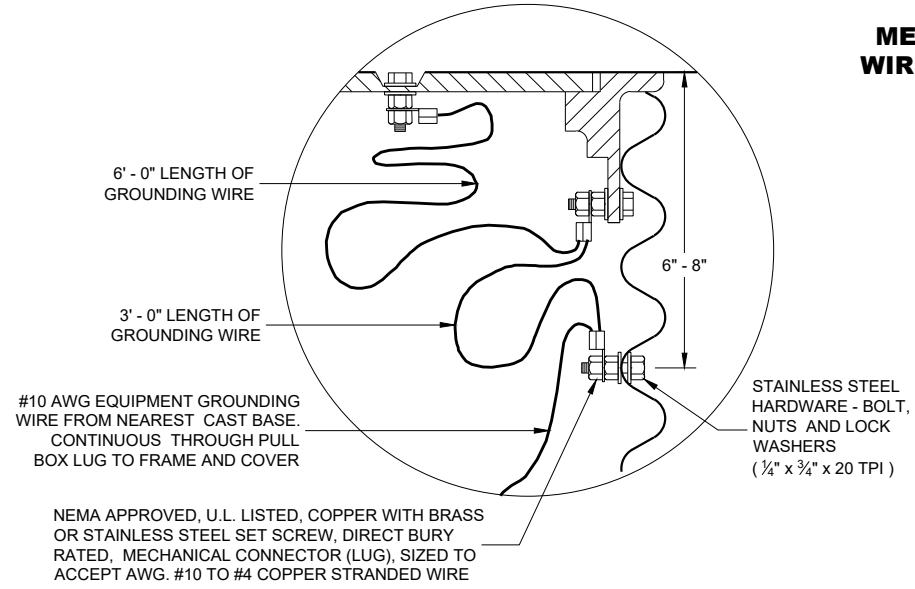

EQUIPMENT GROUNDING LUG AND LOCATION IN STEEL PULL BOXES

NEMA APPROVED, U.L. LISTED, COPPER WITH BRASS OR STAINLESS STEEL SET SCREW, DIRECT BURY RATED, MECHANICAL CONNECTOR (LUG), SIZED TO ACCEPT AWG. #10 TO #4 COPPER STRANDED WIRE

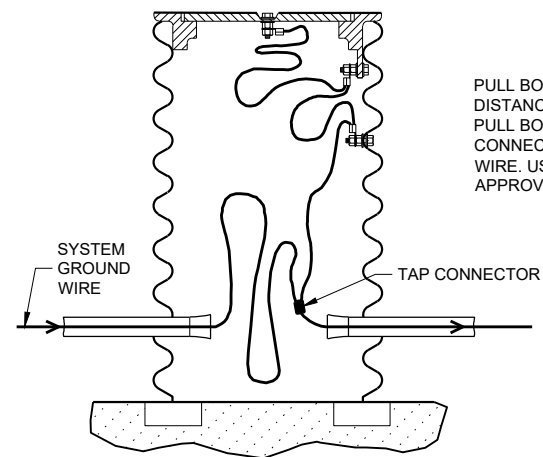

EQUIPMENT GROUNDING LUG AND LOCATION IN STEEL PULL BOXES

PULL BOX TO NEAREST BASE DISTANCE MORE THAN 20 FEET. PULL BOX GROUND WIRE SHALL CONNECT AT SYSTEM GROUNDING WIRE. USE DEPARTMENT APPROVED TAP CONNECTOR.

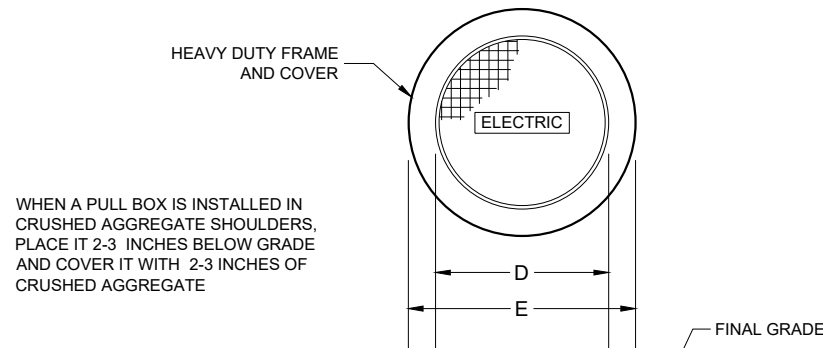

WHEN A PULL BOX IS INSTALLED IN CRUSHED AGGREGATE SHOULDERS, PLACE IT 2-3 INCHES BELOW GRADE AND COVER IT WITH 2-3 INCHES OF CRUSHED AGGREGATE

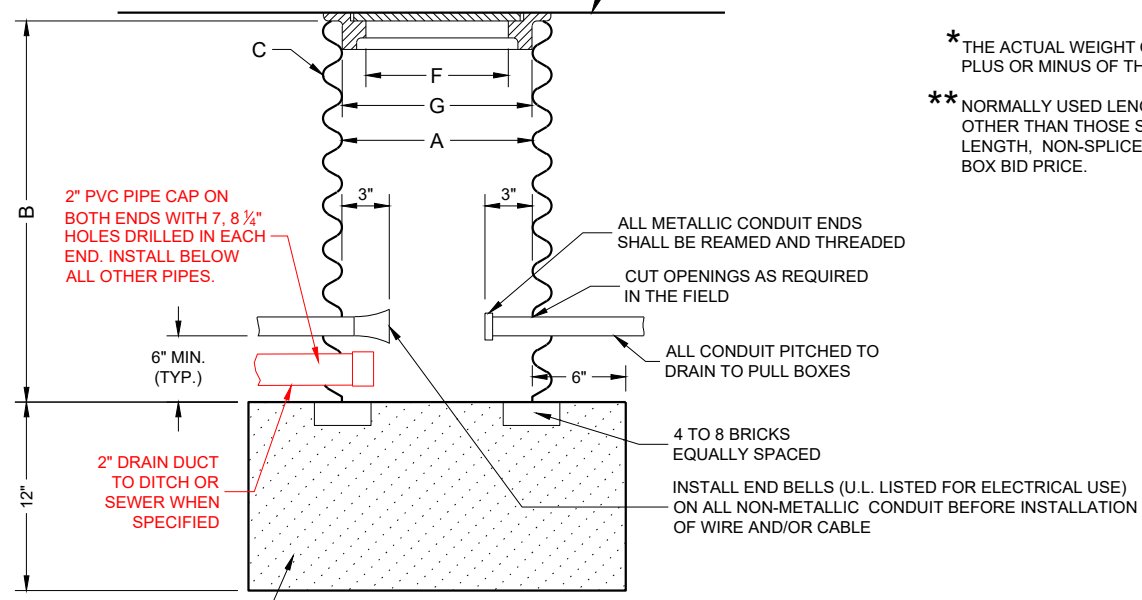

NO. 2 COARSE AGGREGATE (SEE SECTION 501 OF THE STANDARD SPECIFICATIONS)

PULL BOX

PULL BOX

STATE OF WISCONSIN
DEPARTMENT OF TRANSPORTATION

APPROVED
May 2022 /S/ Ahmet Demirbilek
DATE STATE ELECTRICAL ENGINEER

FHWA

FORM DEPTH SHALL BE NO MORE THAN 6" BELOW GRADE ON THE LOWER SIDE OF BASE

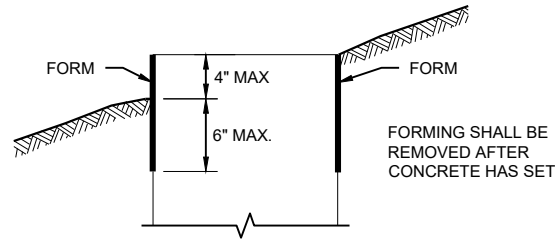

FORMING DETAIL

QUANTITY REQUIREMENTS	CONCRETE BASE TYPE		
	1	2	5 & 6
APPROX. CUBIC YARDS OF CONCRETE	0.40	0.57	0.40
LBS. OF HOOP BAR STEEL	NONE	23	16
LBS. OF VERTICAL BAR STEEL	NONE	60	18

GENERAL NOTES

DETAILS OF CONSTRUCTION, MATERIALS AND WORKMANSHIP NOT SHOWN ON THIS DRAWING SHALL CONFORM TO THE PERTINENT REQUIREMENTS OF THE CONTRACT.

BASES SHALL BE EXCAVATED BY USE OF A CIRCULAR AUGER.

TOP SURFACES OF CONCRETE BASES SHALL BE TROWEL FINISHED SMOOTH AND LEVEL.

CONDUIT SIZES AND LOCATIONS SHALL BE SHOWN ON THE PLANS

THE FINAL OR TERMINATING CONCRETE BASE IN A CONDUIT RUN SHALL HAVE A 6" EXIT STUB INSTALLED FOR FUTURE CABLING USE. THE EXIT STUB SHALL BE SIZED AS USED THROUGHOUT THE CONDUIT RUN AS SHOWN AT THE ENTRANCE OF THE BASE.

ENDS OF CONDUIT INSTALLED BELOW GRADE FOR FUTURE USE SHALL BE CAPPED IF METALLIC OR PLUGGED IF NON-METALLIC.

MINIMUM BENDING RADIUS OF CONDUIT IS EQUAL TO 6X THE DIAMETER.

CONDUIT HEIGHT ABOVE CONCRETE BASES SHALL BE 1 INCH. ALL METALLIC CONDUIT ENDS SHALL BE REAMED AND THREADED.

ALL CONDUIT ENDS AT THE TOP OF CONCRETE BASES SHALL BE CAPPED IF METALLIC OR PLUGGED IF NON-METALLIC IMMEDIATELY AFTER PLACEMENT AND BEFORE CONCRETE IS POURED. CONDUITS IN WHICH WIRE OR CABLE IS NOT INSTALLED SHALL REMAIN CAPPED OR PLUGGED.

BELL ENDS SHALL BE INSTALLED ON ALL PVC CONDUIT EXPOSED AT THE TOP OF CONCRETE BASES BEFORE INSTALLATION.

WHEN REQUIRED TO CONNECT NON-METALLIC CONDUIT TO METALLIC CONDUIT, ONLY ADAPTER FITTINGS, U.L. LISTED FOR ELECTRICAL USE, SHALL BE USED.

IF A BASE REQUIRES A DEEP FORM BECAUSE OF LOOSE DIRT OR FILL, THE FORM SHALL BE REMOVED BEFORE BACKFILLING AROUND THE BASE. BACKFILL SHALL BE TAMPED TIGHT AGAINST THE BARE CONCRETE BASE IN LAYERS OF 1 FOOT OR LESS.

A NO. 4 AWG STRANDED COPPER EQUIPMENT GROUNDING CONDUCTOR SHALL BE EXOTHERMICALLY WELDED TO THE EQUIPMENT GROUNDING ELECTRODE (GROUND ROD) FOR TYPE 2, TYPE 5 AND TYPE 6 BASES.

THE EQUIPMENT GROUNDING CONDUCTOR SHALL BE FURNISHED AND INSTALLED TO ENTER ALL BASE TYPES THROUGH A 1 INCH CONDUIT INSTALLED FOR GROUNDING PURPOSES, LEAVING A 4 FOOT COIL OF WIRE ABOVE THE CONCRETE BASE. THE EQUIPMENT GROUNDING CONDUCTOR SHALL BE NEATLY COILED AND THE COILS TIED TOGETHER.

ANCHOR RODS SHALL BE THREADED 12" IN LENGTH ON EACH END OF THE ROD. ANCHOR RODS SHALL BE MANUFACTURED IN ACCORDANCE WITH SECTION 654.2.1 OF THE STANDARD SPECIFICATIONS.

WASHERS AND LOCK WASHERS ARE REQUIRED ON ALL ANCHOR RODS.

WHEN ANCHOR RODS USING THE ALTERNATE "L" BEND ARE FURNISHED, THE 4 INCH "L" BEND SHALL BE IN ADDITION TO THE SPECIFIED ANCHOR ROD BAR LENGTH. THE "L" BEND SHALL NOT BE THREADED.

ANCHOR RODS SHALL BE INSTALLED WITH MISALIGNMENTS OF LESS THAN 1:40 FROM VERTICAL.

WELDING OF THE ANCHOR RODS TO THE CAGE IS UNACCEPTABLE. TIE WIRES SHALL BE USED.

BAR STEEL REINFORCEMENT SHALL BE COATED WITH POWDERED EPOXY RESIN IN ACCORDANCE WITH SECTION 505 OF THE STANDARD SPECIFICATIONS (LATEST EDITION).

- ① THE MINIMUM DEPTH OF CONDUIT EXITING THE CONCRETE BASE AND INSTALLED BELOW THE TRAVELED WAY SHALL BE 24 INCHES. THE MINIMUM DEPTH OF CONDUIT EXITING THE CONCRETE BASE THAT IS NOT INSTALLED BELOW THE TRAVELED WAY SHALL BE 18 INCHES. THE MAXIMUM DEPTH OF ALL CONDUIT SHALL BE 36 INCHES EXCEPT WITH WRITTEN APPROVAL OF THE ENGINEER.
- ② (4) 1" DIA. X 3' - 6" ANCHOR RODS.
- ③ (4) 1" DIA. X 5' - 0" ANCHOR RODS.
- ④ (6) NO. 6 X 6' - 8" BAR STEEL REINFORCEMENT.
- ⑤ (7) NO. 4 X 5' - 1" BAR STEEL REINFORCEMENT @ 1' - 0" C - C.
- ⑥ (4) 1" DIA. X 3' - 6" ANCHOR RODS.
- ⑦ (6) NO. 4 X 4' - 8" BAR STEEL REINFORCEMENT.
- ⑧ (5) NO. 4 X 5' - 1" BAR STEEL REINFORCEMENT @ 1' - 0" C - C.
- ⑨ EXOTHERMIC CONNECTION TO EQUIPMENT GROUNDING CONDUCTOR
- ⑩ 5/8" DIA. X 8' - 0" COPPERCLAD EQUIPMENT GROUNDING ELECTRODE REQUIRED
- ⑪ ANY ANCHOR ROD PROJECTION SHORTER THAN 2 3/4" OR LONGER THAN 3 1/4" SHALL REQUIRE THE BASE TO BE REMOVED AND REPLACED AT THE CONTRACTORS EXPENSE.
- ⑫ FOR NON - BREAKAWAY INSTALLATIONS, 4 1/2" ± ANCHOR ROD PROJECTION WITH THE USE OF LEVELING NUTS. RODENT SCREEN REQUIRED.

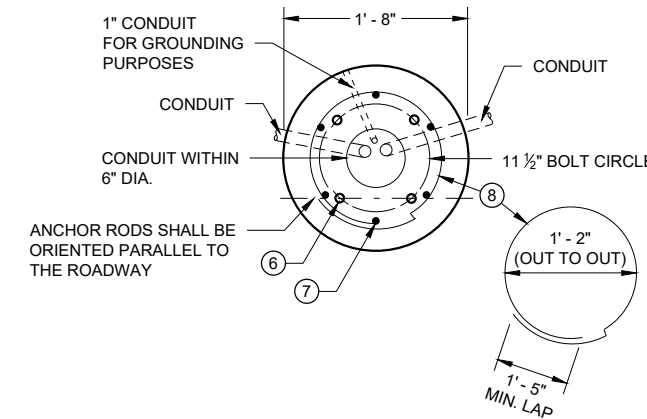
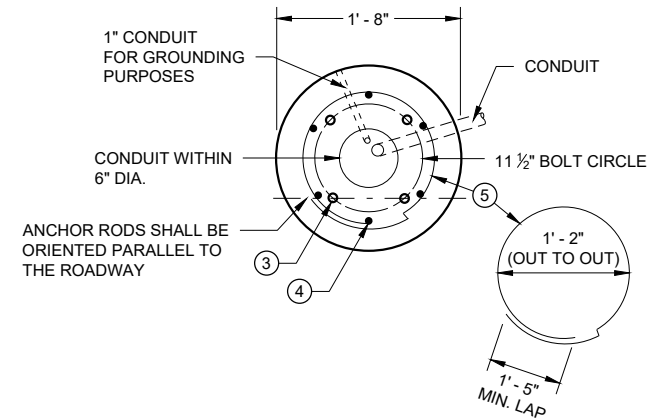
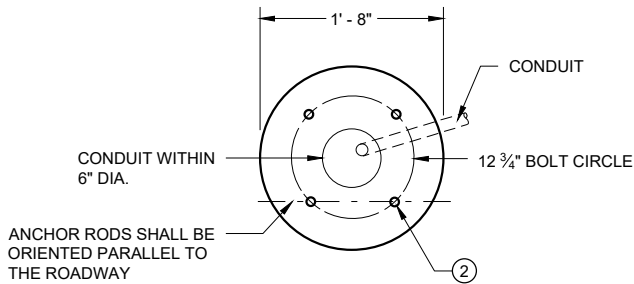

HALF SECTION IN UNPAVED AREA

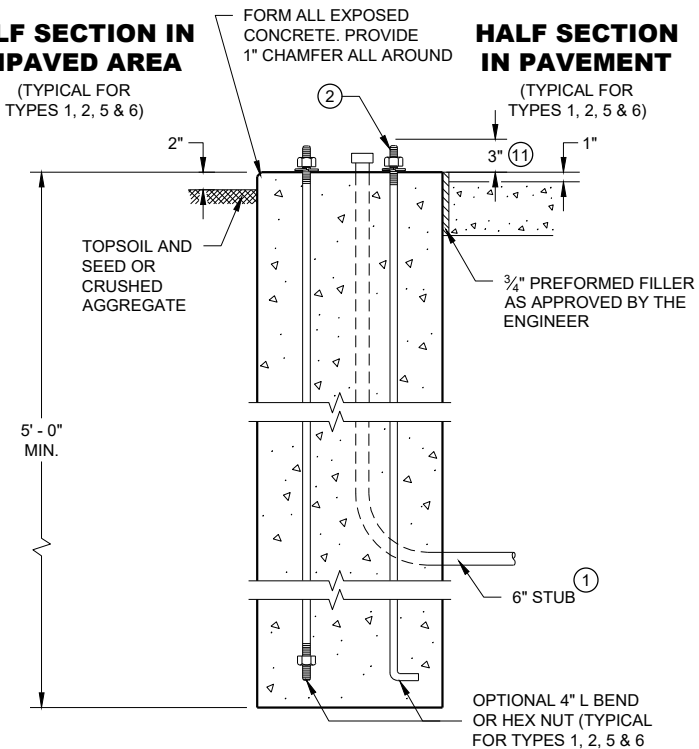

TYPE 1

HALF SECTION IN PAVEMENT

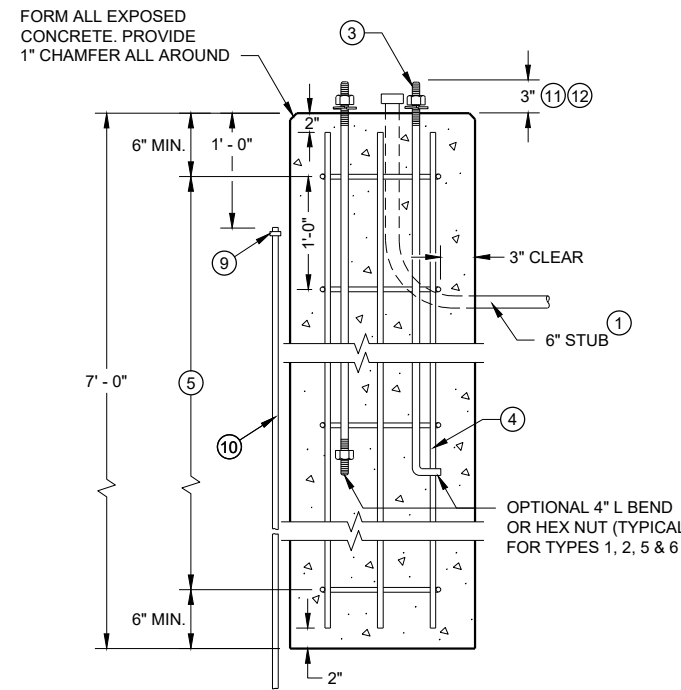

TYPE 2

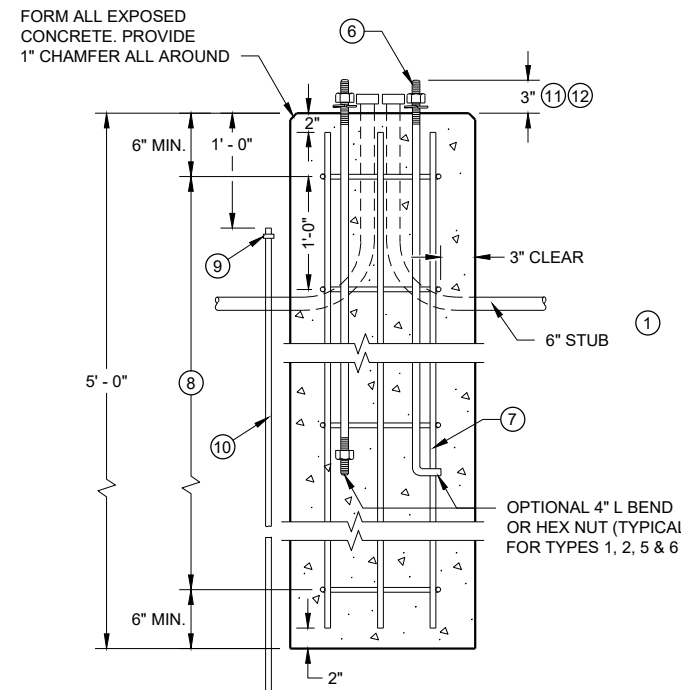

TYPE 5 & 6

CONCRETE BASES

**CONCRETE BASES
TYPES 1, 2, 5, & 6**

STATE OF WISCONSIN
DEPARTMENT OF TRANSPORTATION

APPROVED
May 2019 /S/ Ahmet Demirelek
DATE STATE ELECTRICAL ENGINEER

FHWA

GENERAL NOTES

DETAILS OF CONSTRUCTION, MATERIALS AND WORKMANSHIP NOT SHOWN ON THIS DRAWING SHALL CONFORM TO THE PERTINENT REQUIREMENTS OF THE CONTRACT.

FOUR (4) BOLTS SHALL BE FURNISHED WITH EACH TRANSFORMER BASE. BOLTS SHALL BE 1" DIAMETER, 4" IN LENGTH, WITH WASHERS, LOCK WASHERS AND NUTS. BOLTS, NUTS AND WASHERS SHALL BE MANUFACTURED IN ACCORDANCE WITH SECTION 531.2.2 OF THE STANDARD SPECIFICATIONS.

LEVELING SHIMS, IF NEEDED, SHALL BE DESIGNED FOR THE PURPOSE AND USED UNDER CAST BASES WHEN PLUMBING POLES OR STANDARDS DURING INSTALLATION. THE USE OF WASHERS IN LIEU OF PROPER LEVELING SHIMS IS NOT ACCEPTABLE.

SHIM LENGTH SHALL BE LONG ENOUGH TO COMPLETELY COVER THE AREA UNDER THE LENGTH AND WIDTH OF THE BASE MOUNTING FLANGE.

DOUBLE NUTTING IS NOT ACCEPTABLE FOR LEVELING OR MOUNTING PURPOSES.

A NEMA APPROVED, U.L. LISTED, COPPER WITH BRASS OR STAINLESS STEEL SET SCREW, DIRECT BURY RATED, MECHANICAL CONNECTOR (LUG), SIZED TO ACCEPT AWG. #10 TO #4 COPPER STRANDED WIRE SHALL BE FURNISHED AND INSTALLED IN THE PEDESTAL AND TRANSFORMER BASES.

THE MECHANICAL CONNECTOR SHALL BE INSTALLED USING A 1/4" - 20 (TPI) STAINLESS STEEL HEX HEAD BOLT OF SUFFICIENT LENGTH TO FIRMLY ATTACH THE LUG TO THE BASE.

SHOULD THE MANNER OF ATTACHMENT OF THE LUG REQUIRE WASHERS, HEX NUTS, LOCK WASHER - THEY SHALL BE STAINLESS STEEL AS IS THE BOLT. THE MANNER OF ATTACHMENT SHALL NOT BLOCK ACCESSIBILITY TO WIRE PLACEMENT IN THE CONNECTOR.

PEDESTAL BASE COLLAR THREADING SHALL BE TAPERED AND IN ACCORDANCE WITH NATIONAL PIPE THREADING DIMENSIONS.

BASE COLLAR THREADING SHALL EXTEND INTO THE BASE COLLAR WITH SUFFICIENT DEPTH TO ACCEPT THE INSTALLATION OF TRAFFIC SIGNAL STANDARDS TO A DEPTH OF 1/2", THEN TIGHTENING TO A POINT OF BEING IMMOVABLE.

THE ACCESS DOOR SHALL BE OF THE SAME MATERIAL AS THE BASE.

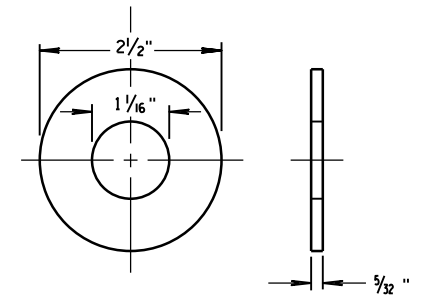
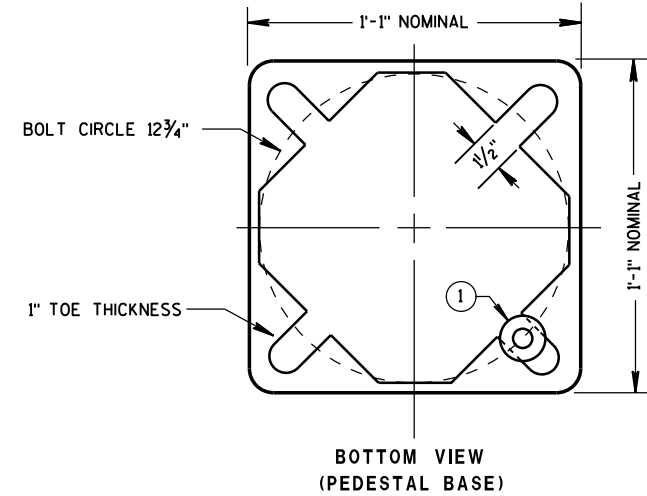
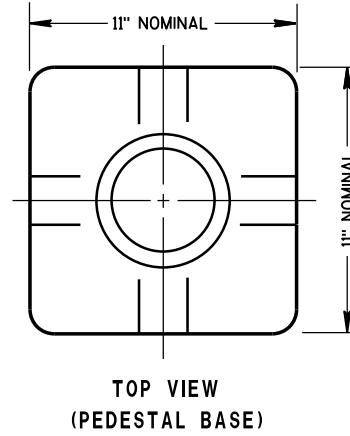
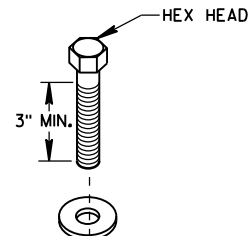

ZINC COATED STEEL WASHER TO BE PROVIDED BY THE CONTRACTOR

PEDESTAL BASE WASHER ①

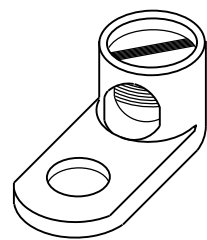
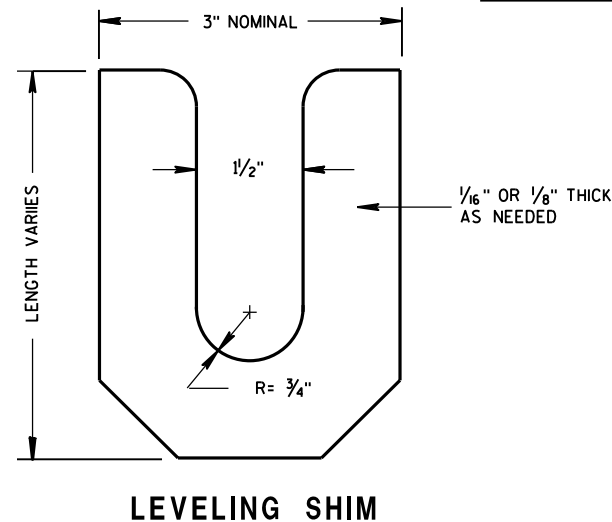
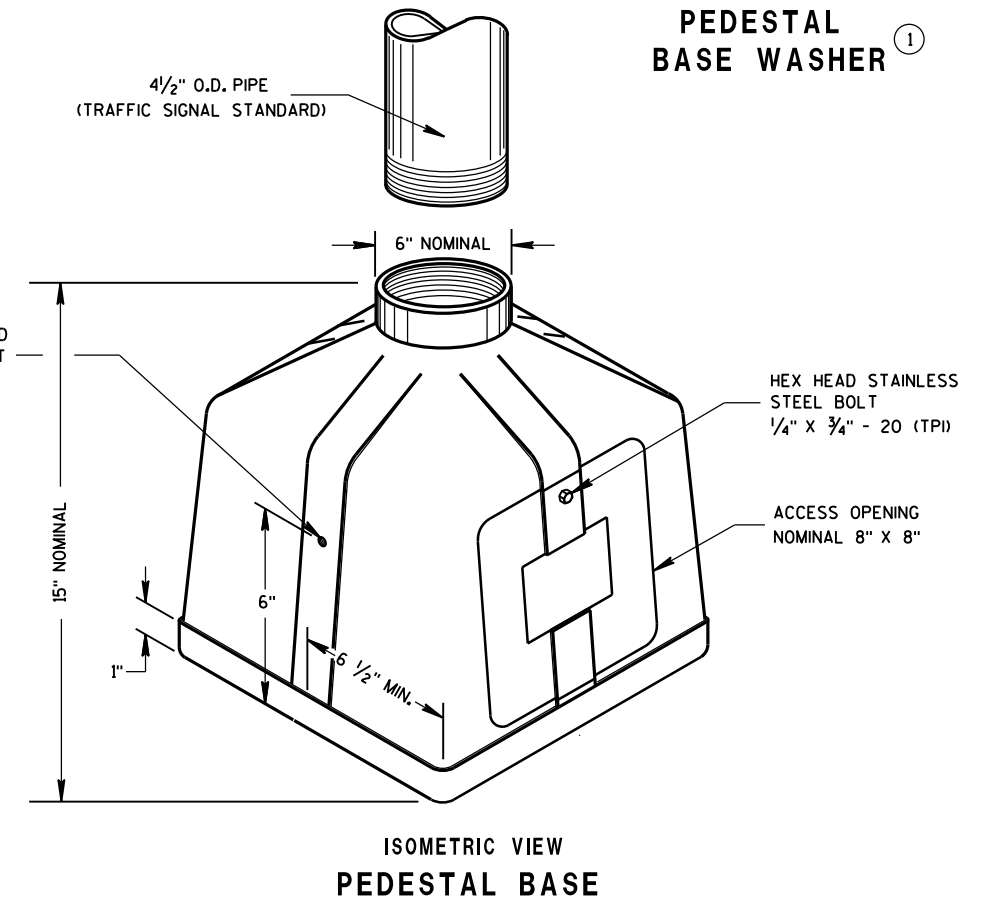
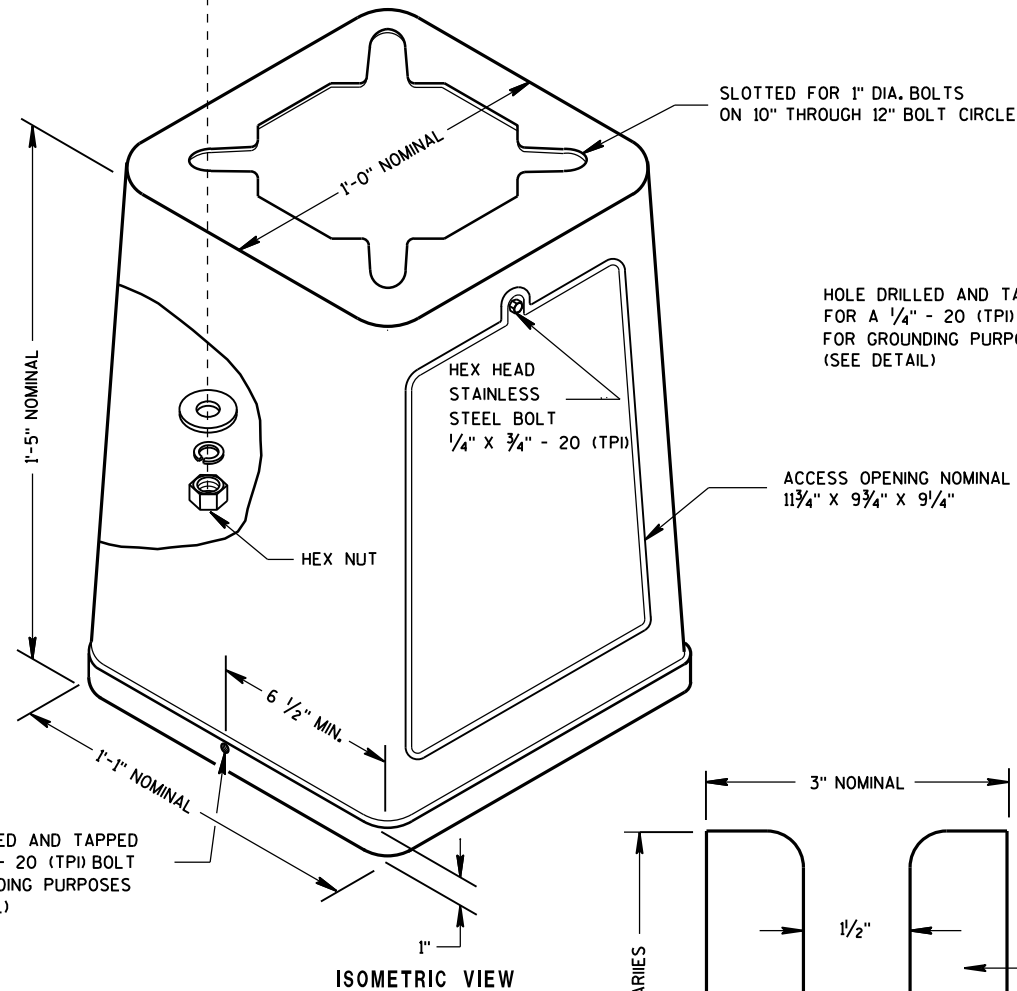
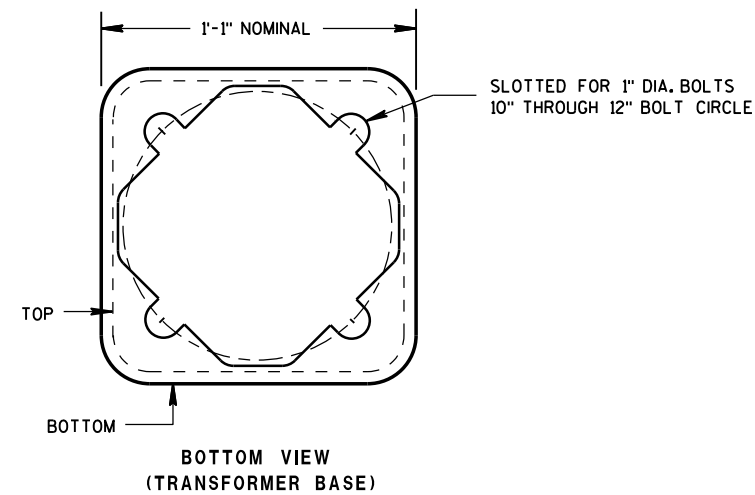

TYPICAL MECHANICAL CONNECTOR LUG

TO BE FURNISHED WITH EACH BASE

TRANSFORMER BASE

INTENDED FOR USE WITH TYPE 2, 3, 4, 5 & 6 POLES

TRANSFORMER/PEDESTAL BASES	
STATE OF WISCONSIN DEPARTMENT OF TRANSPORTATION	
APPROVED Sept. 2014 DATE	/S/ Ahmet Demirbilek STATE ELECTRICAL ENGINEER
FHWA	

6

6

S.D.D. 9 C 3-4

S.D.D. 9 C 3-4



SDD 09C06 Concrete Control Cabinet Base, Type 9, Special

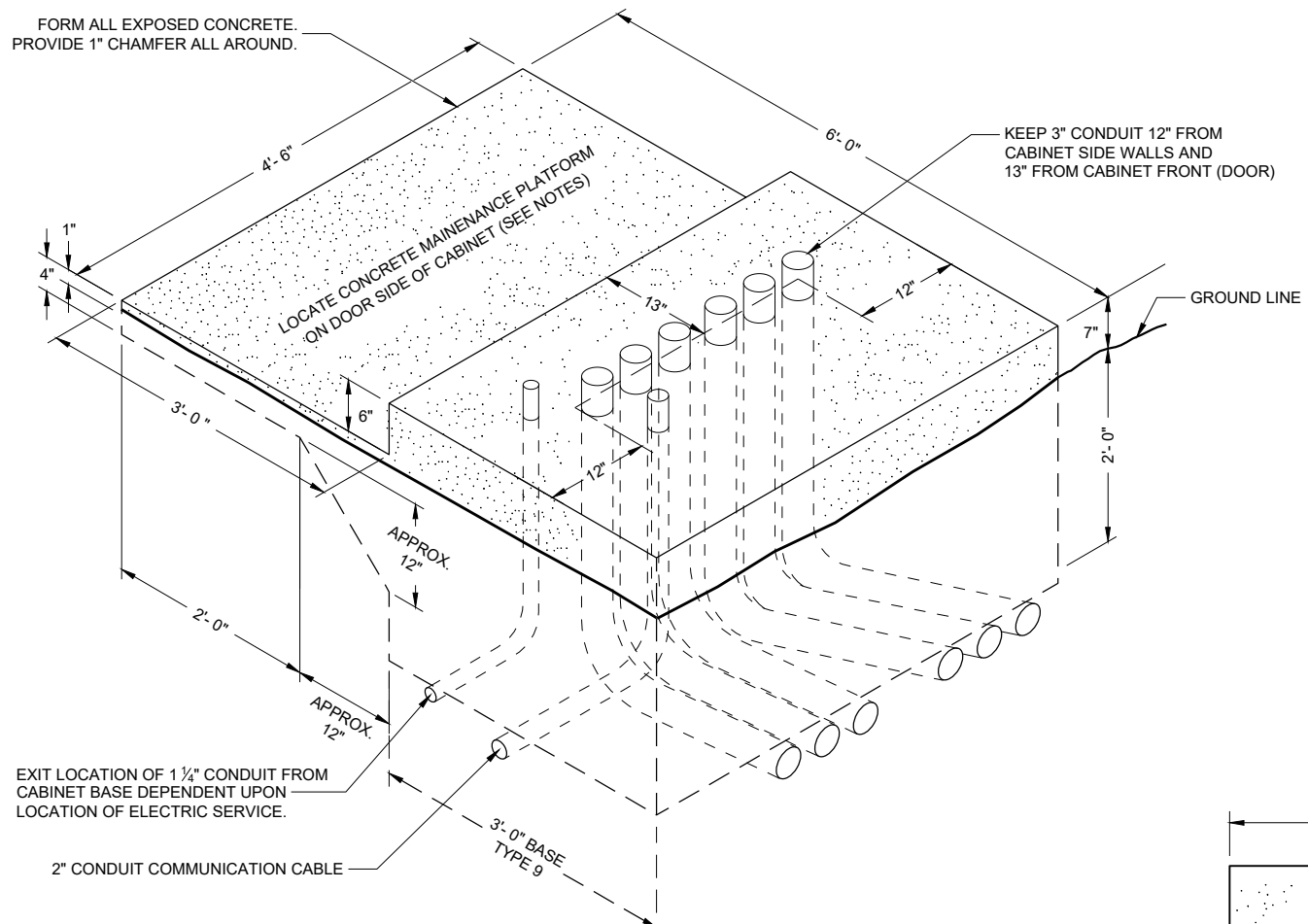

ISOMETRIC VIEW TYPE 9 SPECIAL

(C.Y. CONCRETE = APPROX. 1.56)

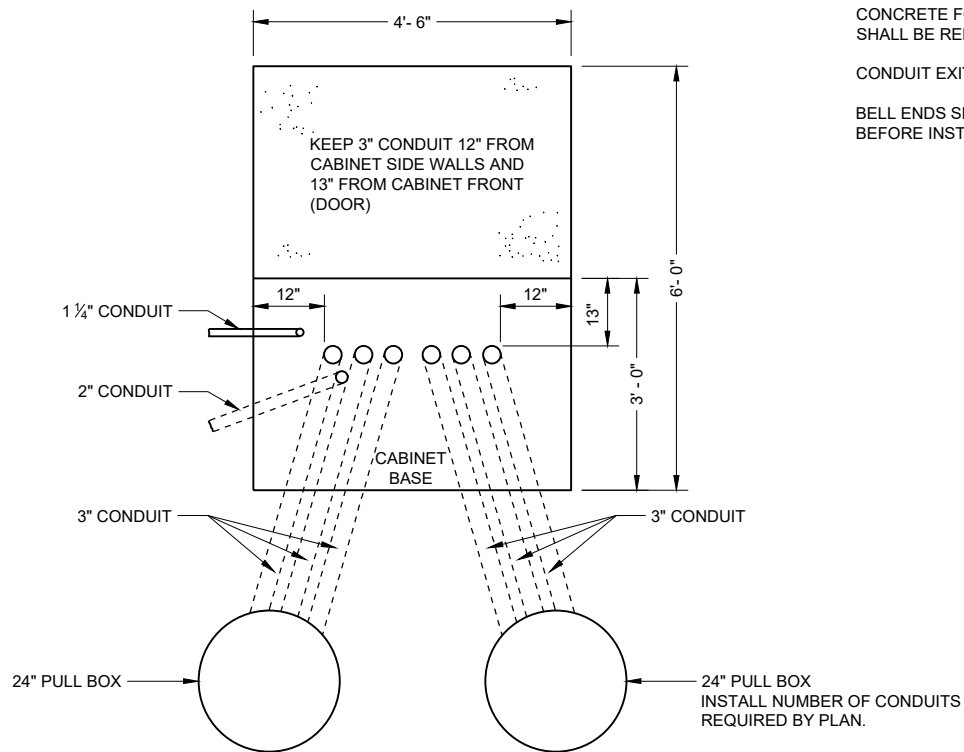

PLAN VIEW CONCRETE CONTROL CABINET BASE, TYPE 9 SPECIAL

GENERAL NOTES

DETAILS OF CONSTRUCTION, MATERIALS AND WORKMANSHIP NOT SHOWN ON THIS DRAWING SHALL CONFORM TO THE PERTINENT REQUIREMENTS OF THE CONTRACT.

INSTALL FOUR INCH MINIMUM DIAMETER X 4 INCH MINIMUM LENGTH STAINLESS STEEL APPROVED CONCRETE MASONRY ANCHORS WITH A PULLOUT STRENGTH OF 9,000 LBS. TO ANCHOR THE CABINET TO TYPE 6, 7, 8, AND 9 BASES. THE ANCHOR STUDS SHALL BE LOCATED AS DIRECTED BY THE ENGINEER TO PROPERLY ANCHOR THE CONTROL CABINET TO THE BASE.

WHEN REQUIRED TO CONNECT NON - METALLIC CONDUIT TO METALLIC CONDUIT, ONLY ADAPTER FITTINGS, U. L. LISTED FOR ELECTRICAL USE, SHALL BE USED.

CONDUIT HEIGHT ABOVE THE CONCRETE BASE SHALL BE 1 INCH.

DEPTH OF CONDUIT INSTALLED BELOW THE TRAVELED WAY SHALL BE 24 INCHES MINIMUM AND 36 INCHES MAXIMUM.

DEPTH OF CONDUIT INSTALLED THAT IS NOT BELOW THE TRAVELED WAY SHALL BE 18 INCHES MINIMUM AND 36 INCHES MAXIMUM.

ANY EXCEPTION TO THE MAXIMUM DEPTH SHALL BE ONLY WITH THE WRITTEN APPROVAL OF THE ENGINEER.

CONTROL CABINET BASE TOP SURFACE SHALL BE TROWEL FINISHED SMOOTH AND LEVEL.

MAINTENANCE PLATFORM SHALL BE FLOAT OR BROOM FINISHED AND LEVEL.

MAINTENANCE PLATFORMS ARE NOT REQUIRED WHEN THE SURROUNDING AREA IS PAVED.

MINIMUM BENDING RADIUS OF CONDUIT EQUALS 6 TIMES THE DIAMETER.

ALL METALLIC CONDUIT ENDS SHALL BE REAMED AND THREADED.

CAP ALL BELOW GRADE METALLIC CONDUIT ENDS IN WHICH WIRE OR CABLE IS NOT BEING INSTALLED.

PLUG ALL BELOW GRADE NON - METALLIC CONDUIT ENDS IN WHICH WIRE OR CABLE IS NOT BEING INSTALLED.

ALL CONDUIT ENDS AT THE TOP OF CONCRETE BASES SHALL BE CAPPED IF METALLIC OR PLUGGED IF NON - METALLIC IMMEDIATELY AFTER PLACEMENT AND BEFORE CONCRETE IS POURED. CONDUITS IN WHICH WIRE OR CABLE IS NOT BEING INSTALLED SHALL REMAIN CAPPED OR PLUGGED.

CONCRETE FORM DEPTH BELOW FINISHED GRADE SHALL BE 6 INCHES MAXIMUM. CONCRETE FORMS SHALL BE REMOVED AFTER CONCRETE HAS SET.

CONDUIT EXITING THE CONCRETE BASE (SIX 3") SHALL TERMINATE IN PULL BOXES AS SHOWN ON THE PLANS.

BELL ENDS SHALL BE INSTALLED ON ALL PVC CONDUIT EXPOSED AT THE TOP OF THE CONCRETE BASE BEFORE INSTALLATION OF CABLE OR WIRE.

6

6

SDD 09C06 - 07

SDD 09C06 - 07

CONCRETE CONTROL CABINET BASE TYPE 9, SPECIAL

STATE OF WISCONSIN
DEPARTMENT OF TRANSPORTATION

APPROVED
September 2014 /S/ Ahmet Demerbilek
DATE STATE ELECTRICAL ENGINEER
FHWA

GENERAL NOTES

DETAILS OF CONSTRUCTION, MATERIALS AND WORKMANSHIP NOT SHOWN ON THIS DRAWING SHALL CONFORM TO THE PERTINENT REQUIREMENTS OF THE CONTRACT.

BASES (SHAFT) SHALL BE EXCAVATED BY THE USE OF A CIRCULAR AUGER. IF BASE REQUIRES A DEEP FORM BECAUSE OF LOOSE SOIL, THE FORM SHALL BE REMOVED BEFORE BACKFILLING. A STEEL CASING OR CORRUGATED METAL PIPE IS ALLOWED TO REMAIN. BACKFILL SHALL BE TAMPED TIGHT AGAINST THE BASE IN LAYERS OF ONE FOOT OR LESS.

TOP SURFACE OF THE CONCRETE BASE SHALL BE TROWEL FINISHED AND LEVEL.

ANCHOR RODS SHALL BE INSTALLED WITH MISALIGNMENTS OF LESS THAN 1:40 FROM VERTICAL.

BAR STEEL REINFORCEMENT SHALL BE COATED WITH POWDERED EPOXY RESIN IN ACCORDANCE WITH SECTION 505 OF THE STANDARD SPECIFICATIONS (LATEST EDITION).

WELDING OF ANCHOR RODS TO THE CAGE IS UNACCEPTABLE. TEMPLATES SHALL BE USED.

CONDUIT SIZES AND LOCATIONS SHALL BE SHOWN ON THE PLANS.

MINIMUM BENDING RADIUS OF CONDUIT IS EQUAL TO 6 TIMES THE DIAMETER.

CONDUIT HEIGHT ABOVE CONCRETE BASES SHALL BE 4" INCHES. ALL METALLIC CONDUIT ENDS SHALL BE REAMED AND THREADED. NON-METALLIC CONDUIT SHALL HAVE BELL ENDS INSTALLED. ALL CONDUIT SHALL SLOPE TO PULL BOX.

ALL CONDUIT ENDS AT THE TOP OF CONCRETE BASES SHALL BE CAPPED IF METALLIC OR PLUGGED IF NON-METALLIC IMMEDIATELY AFTER PLACEMENT AND BEFORE CONCRETE IS POURED. CONDUITS IN WHICH WIRE OR CABLE IS NOT INSTALLED SHALL REMAIN CAPPED OR PLUGGED.

BELL ENDS SHALL BE INSTALLED ON ALL PVC CONDUIT EXPOSED AT THE TOP OF CONCRETE BASES BEFORE INSTALLATION OF CABLE OR WIRE.

WHEN REQUIRED TO CONNECT NON-METALLIC CONDUIT TO METALLIC CONDUIT, ONLY ADAPTER FITTINGS, U.L. LISTED FOR ELECTRICAL USE, SHALL BE USED.

ENDS OF CONDUIT INSTALLED BELOW GRADE FOR FUTURE USE SHALL BE CAPPED IF METALLIC OR PLUGGED IF NONMETALLIC.

A NO. 4 AWG STRANDED COPPER EQUIPMENT GROUNDING CONDUCTOR SHALL BE EXOTHERMICALLY WELDED TO THE EQUIPMENT GROUNDING ELECTRODE (GROUND ROD).

THE EQUIPMENT GROUNDING CONDUCTOR SHALL BE FURNISHED AND INSTALLED TO ENTER THE BASE THROUGH A 1 INCH CONDUIT INSTALLED FOR GROUNDING PURPOSES, LEAVING A 4 FOOT COIL OF WIRE ABOVE THE CONCRETE BASE. THE EQUIPMENT GROUNDING CONDUCTOR SHALL BE NEATLY COILED AND THE COILS TIED TOGETHER.

THE FINAL OR TERMINATING CONCRETE BASE IN A CONDUIT RUN SHALL HAVE A 6" EXIT STUB INSTALLED FOR FUTURE CABLING USE. THE EXIT STUB SHALL BE SIZED AS USED THROUGHOUT THE CONDUIT RUN AS SHOWN AT THE ENTRANCE OF THE BASE.

① THE MINIMUM DEPTH OF CONDUIT EXITING THE CONCRETE BASE AND INSTALLED BELOW THE TRAVELED WAY SHALL BE 24 INCHES. THE MINIMUM DEPTH OF CONDUIT EXITING THE CONCRETE BASE THAT IS NOT INSTALLED BELOW THE TRAVELED WAY SHALL BE 18 INCHES. THE MAXIMUM DEPTH OF ALL CONDUIT SHALL BE 36 INCHES (GREATER THAN 36 INCHES IF INSTALLED IN BREAKER RUN) EXCEPT WITH WRITTEN APPROVAL OF THE ENGINEER.

② (6) 1 1/2" DIA. X 4' - 4" ANCHOR RODS

③ (6) NO. 6 X 13' - 7" BAR STEEL REINFORCEMENT.

④ (21) NO. 5 X 7'-10" BAR STEEL REINFORCEMENT @ 8" MAX. C-C.

CONCRETE MASONRY.....fc = 3,500 p.s.i.
 HIGH STRENGTH BAR STEEL REINFORCEMENT, GRADE 60.....fy = 60,000 p.s.i.
 ANCHOR RODS, ASTM F1554 GRADE 55 (IN ACCORDANCE WITH SECTION 531.2.2 OF THE STANDARD SPECIFICATION).....fy = 55,000 p.s.i.
 TEMPLATES, ASTM A709, GRADE 36.....fy = 36,000 p.s.i.

QUANTITY REQUIREMENTS	
APPROX. CUBIC YARDS OF CONCRETE	2.5
LBS. OF HOOP BAR STEEL	172
LBS. OF VERTICAL BAR STEEL	122

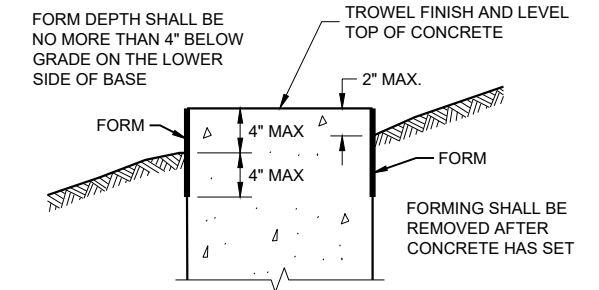
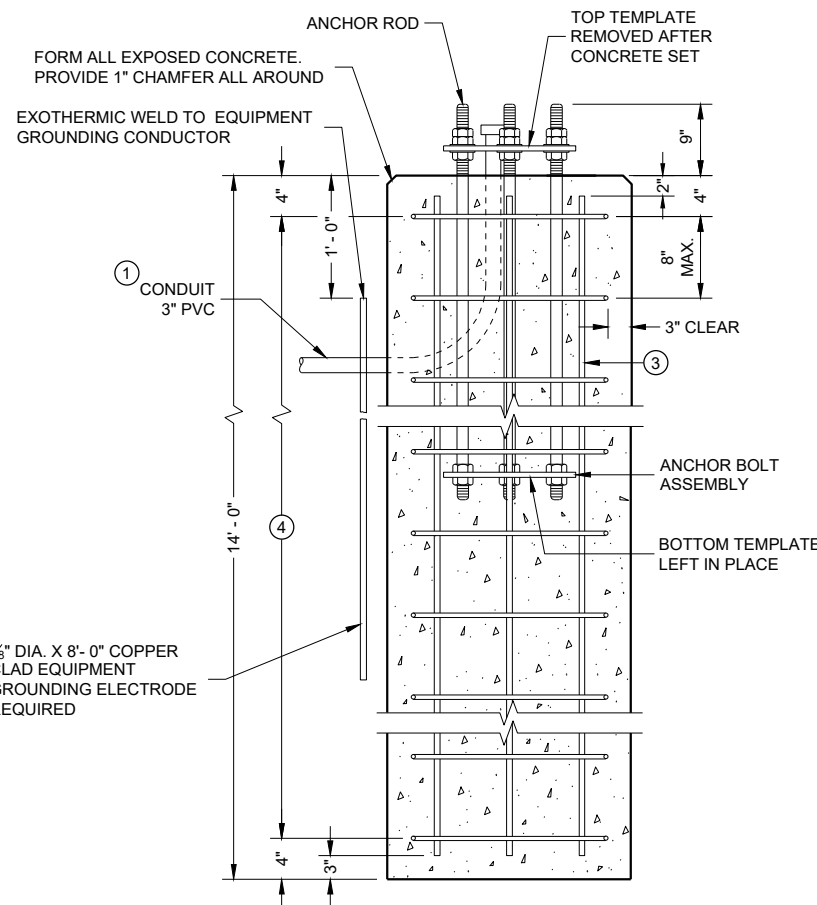
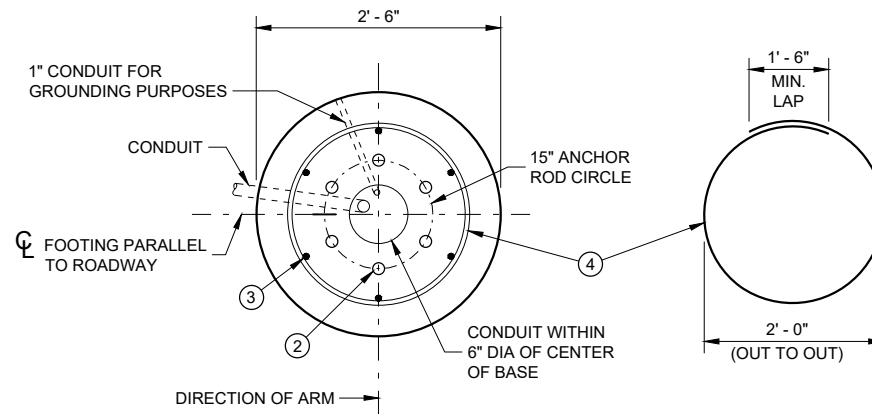

FORMING DETAIL

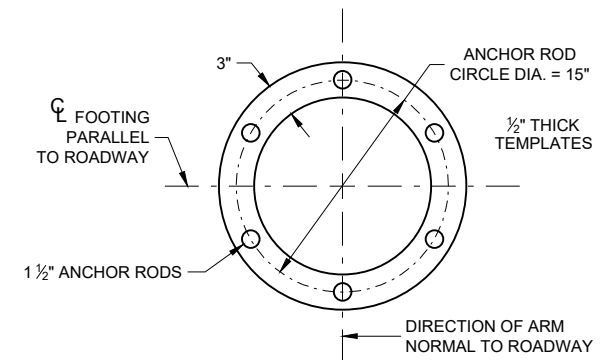

TOP AND BOTTOM TEMPLATE

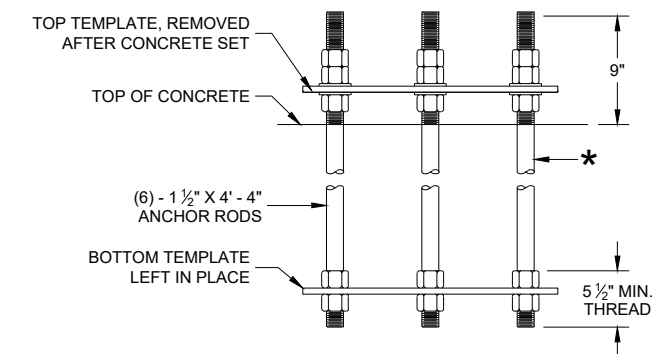

ANCHOR ROD ASSEMBLY DETAILS

* THREAD TOP 10" OF ANCHOR ROD FOR 3 NUTS AND 2 WASHERS AND BOTTOM 5 1/2" FOR 2 NUTS PER ANCHOR ROD. HOT DIP GALVANIZE THE ENTIRE LENGTH OF THE ANCHOR ROD (ASTM A123) AND HOT DIP NUTS AND WASHERS (ASTM A153). USE ZINC COATED NUTS MANUFACTURED WITH SUFFICIENT ALLOWANCE TO ALLOW NUTS TO RUN FREELY ON THE THREADS.

CONCRETE BASE, TYPE 10 (FOR TYPE 9, TYPE 10 AND OVER HEIGHT (OH) POLES)

TO BE USED WHEN GROUND ELEVATION AT BASE EQUALS OR IS GREATER THAN HIGH POINT OF ROADWAY ELEVATION. SEE SDD 9C13 WHEN GROUND ELEVATION AT BASE IS LOWER THAN HIGH POINT OF ROADWAY ELEVATION.

CONCRETE BASE TYPE 10

STATE OF WISCONSIN
DEPARTMENT OF TRANSPORTATION

APPROVED
May 2017 /S/ Ahmet Demerbilek
DATE WIND LOADED STRUCTURES PROGRAM LEADER

FHWA

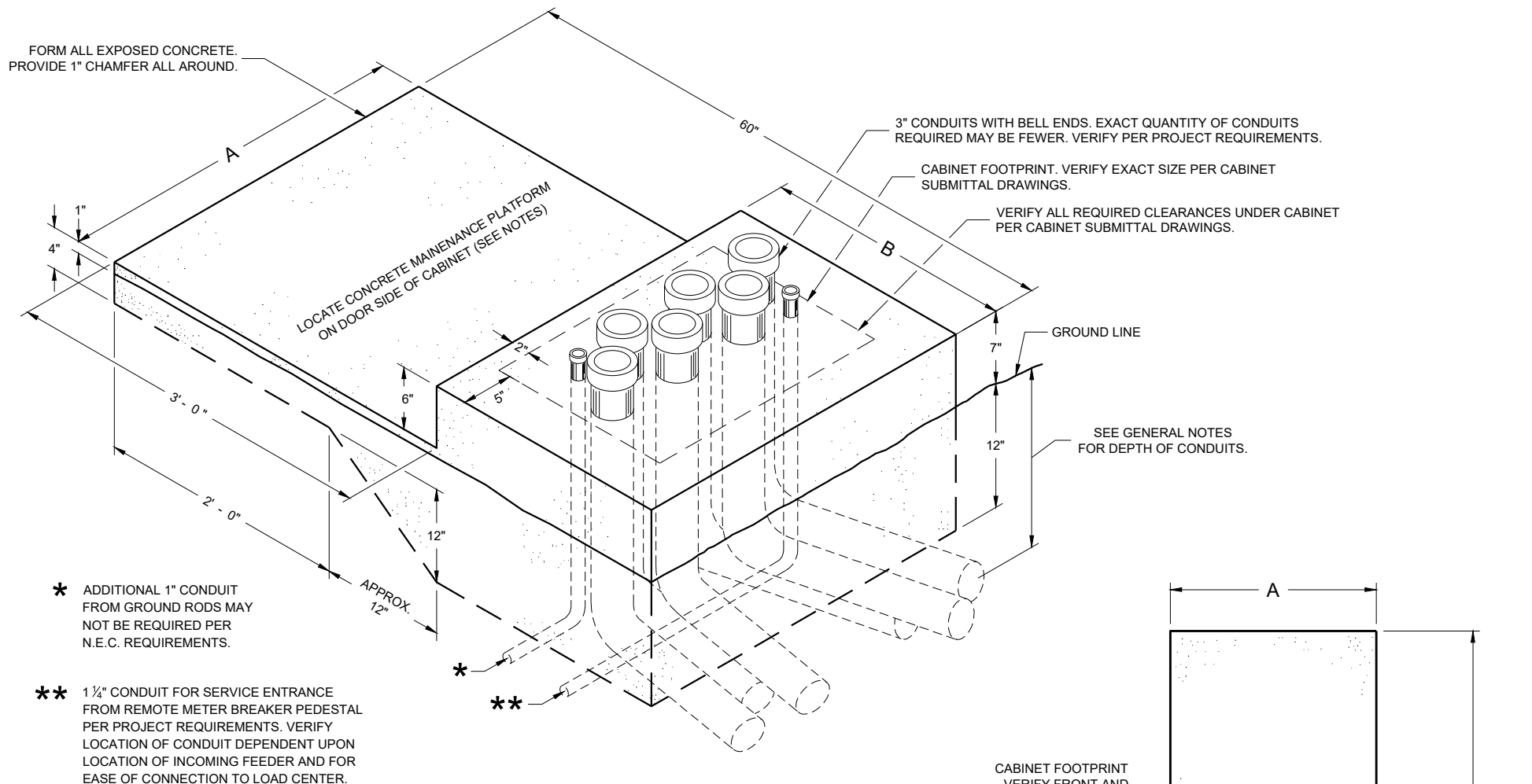

**ISOMETRIC VIEW
CONCRETE CONTROL CABINET BASE, TYPE L**
(C.Y. CONCRETE = APPROX. 0.4)

- * ADDITIONAL 1" CONDUIT FROM GROUND RODS MAY NOT BE REQUIRED PER N.E.C. REQUIREMENTS.
- ** 1 1/2" CONDUIT FOR SERVICE ENTRANCE FROM REMOTE METER BREAKER PEDESTAL PER PROJECT REQUIREMENTS. VERIFY LOCATION OF CONDUIT DEPENDENT UPON LOCATION OF INCOMING FEEDER AND FOR EASE OF CONNECTION TO LOAD CENTER.

CONCRETE BASE TYPE	CABINET WIDTH	DIMENSIONS		MAXIMUM 3" CONDUITS
		A	B	
L24	24"	34"	24"	4
L30	30"	40"	24"	6

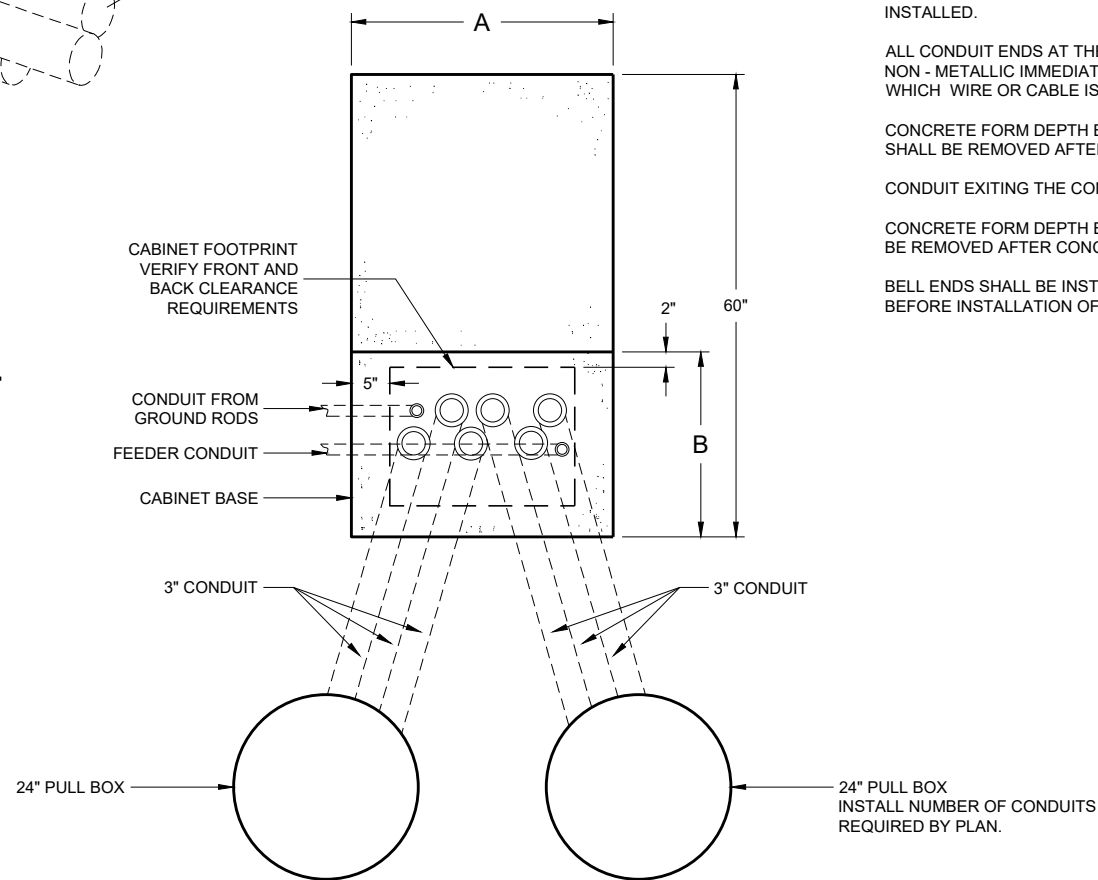

**PLAN VIEW
CONCRETE CONTROL CABINET BASE, TYPE L**

GENERAL NOTES

- DETAILS OF CONSTRUCTION, MATERIALS AND WORKMANSHIP NOT SHOWN ON THIS DRAWING SHALL CONFORM TO THE PERTINENT REQUIREMENTS OF THE CONTRACT.
- INSTALL FOUR STAINLESS STEEL APPROVED CONCRETE MASONRY ANCHORS TO ANCHOR THE CABINET BASES. THE ANCHORS SHALL BE LOCATED AS DIRECTED BY THE ENGINEER TO PROPERLY ANCHOR THE CONTROL CABINET TO THE BASE.
- WHEN REQUIRED TO CONNECT NON - METALLIC CONDUIT TO METALLIC CONDUIT, ONLY ADAPTER FITTINGS, U. L. LISTED FOR ELECTRICAL USE, SHALL BE USED.
- CONDUIT HEIGHT ABOVE THE CONCRETE BASE SHALL BE 1 INCH.
- DEPTH OF CONDUIT INSTALLED BELOW THE TRAVELED WAY SHALL BE 24 INCHES MINIMUM AND 36 INCHES MAXIMUM.
- DEPTH OF CONDUIT INSTALLED THAT IS NOT BELOW THE TRAVELED WAY SHALL BE 18 INCHES MINIMUM AND 36 INCHES MAXIMUM.
- ANY EXCEPTION TO THE MAXIMUM DEPTH SHALL BE ONLY WITH THE WRITTEN APPROVAL OF THE ENGINEER.
- LOCATIONS SHALL BE AS SHOWN ON THE PLANS UNLESS DETERMINED BY THE ENGINEER IN THE FIELD.
- CONTROL CABINET BASE TOP SURFACE SHALL BE TROWEL FINISHED SMOOTH AND LEVEL.
- MAINTENANCE PLATFORM SHALL BE FLOAT OR BROOM FINISHED AND LEVEL.
- MAINTENANCE PLATFORMS ARE NOT REQUIRED WHEN THE SURROUNDING AREA IS PAVED.
- MINIMUM BENDING RADIUS OF CONDUIT EQUALS 6 TIMES THE DIAMETER.
- ALL METALLIC CONDUIT ENDS SHALL BE REAMED AND THREADED.
- CAP ALL BELOW GRADE METALLIC CONDUIT ENDS IN WHICH WIRE OR CABLE IS NOT BEING INSTALLED.
- PLUG ALL BELOW GRADE NON - METALLIC CONDUIT ENDS IN WHICH WIRE OR CABLE IS NOT BEING INSTALLED.
- ALL CONDUIT ENDS AT THE TOP OF CONCRETE BASES SHALL BE CAPPED IF METALLIC OR PLUGGED IF NON - METALLIC IMMEDIATELY AFTER PLACEMENT AND BEFORE CONCRETE IS Poured. CONDUITS IN WHICH WIRE OR CABLE IS NOT BEING INSTALLED SHALL REMAIN CAPPED OR PLUGGED.
- CONCRETE FORM DEPTH BELOW FINISHED GRADE SHALL BE 6 INCHES MAXIMUM. CONCRETE FORMS SHALL BE REMOVED AFTER CONCRETE HAS SET.
- CONDUIT EXITING THE CONCRETE BASE SHALL TERMINATE IN PULL BOXES AS SHOWN ON THE PLANS.
- CONCRETE FORM DEPTH BELOW FINISHED GRADE SHALL BE 6 INCH MAXIMUM. CONCRETE FORMS SHALL BE REMOVED AFTER CONCRETE HAS SET.
- BELL ENDS SHALL BE INSTALLED ON ALL PVC CONDUIT EXPOSED AT THE TOP OF THE CONCRETE BASE BEFORE INSTALLATION OF CABLE OR WIRE.

**CONCRETE CONTROL
CABINET BASE, TYPE L**

STATE OF WISCONSIN
DEPARTMENT OF TRANSPORTATION

APPROVED
November 2018 /S/ Ahmet Demirbilek
DATE STATE ELECTRICAL ENGINEER
FHWA

GENERAL NOTES

DETAILS OF CONSTRUCTION, MATERIALS AND WORKMANSHIP NOT SHOWN ON THIS DRAWING SHALL CONFORM TO THE PERTINENT REQUIREMENTS OF THE CONTRACT.

THE CONTRACTOR IS RESPONSIBLE FOR MAKING THEIR OWN DETERMINATION AS TO THE TYPE AND LOCATION OF UNDERGROUND UTILITIES AS MAY BE NECESSARY TO AVOID DAMAGE THERETO.

BASES (SHAFT) SHALL BE EXCAVATED BY THE USE OF A CIRCULAR AUGER. IF BASE REQUIRES A DEEP FORM BECAUSE OF LOOSE SOIL, THE FORM SHALL BE REMOVED BEFORE BACKFILLING. A STEEL CASING OR CORRUGATED METAL PIPE IS ALLOWED TO REMAIN. BACKFILL SHALL BE TAMPED TIGHT AGAINST THE BASE IN LAYERS OF ONE FOOT OR LESS.

TOP SURFACE OF THE CONCRETE BASE SHALL BE TROWEL FINISHED AND LEVEL.

ANY DAMAGE TO THE CONCRETE BASE AND ANCHOR RODS DURING CONSTRUCTION OPERATIONS SHALL BE REPAIRED AT THE ENGINEER'S DIRECTION, AT THE EXPENSE OF THE CONTRACTOR.

THE REINFORCEMENT AND ANCHOR RODS SHALL BE ADEQUATELY SUPPORTED IN THE PROPER POSITIONS SO NO MOVEMENT OCCURS DURING CONCRETE PLACEMENT.

ORIENT ANCHOR RODS IN FOOTING AND PROVIDE ANCHOR RODS STICK OUT ABOVE TOP OF CONCRETE FOOTING BASE PER THIS SHEET.

ANCHOR RODS SHALL BE INSTALLED WITH MISALIGNMENTS OF LESS THAN 1:40 FROM VERTICAL.

BAR STEEL REINFORCEMENT SHALL BE COATED WITH POWDERED EPOXY RESIN IN ACCORDANCE WITH SECTION 505 OF THE STANDARD SPECIFICATIONS (LATEST EDITION).

BENDING DIMENSIONS FOR REINFORCING BARS ARE OUT TO OUT.

WELDING OF ANCHOR RODS TO THE CAGE IS UNACCEPTABLE. TEMPLATES SHALL BE USED.

USE 3" CLEAR FOR ALL REINFORCEMENT UNLESS NOTED OTHERWISE.

FORM ALL EXPOSED CONCRETE CORNERS WITH 1" CHAMFER ALL AROUND. TOP OF THE CONCRETE BASE SHALL BE TROWEL FINISHED AND LEVEL.

CONDUIT SIZES AND LOCATIONS SHALL BE SHOWN ON THE PLANS.

MINIMUM BENDING RADIUS OF CONDUIT IS EQUAL TO 6 TIMES THE DIAMETER.

CONDUIT HEIGHT ABOVE CONCRETE BASES SHALL BE 4 1/2" INCHES. ALL METALLIC CONDUIT ENDS SHALL BE REAMED AND THREADED. NON-METALLIC CONDUIT SHALL HAVE BELL ENDS INSTALLED. ALL CONDUIT SHALL SLOPE TO PULL BOX.

ALL CONDUIT ENDS AT THE TOP OF CONCRETE BASES SHALL BE CAPPED IF METALLIC OR PLUGGED IF NON-METALLIC IMMEDIATELY AFTER PLACEMENT AND BEFORE CONCRETE IS POURED. CONDUITS IN WHICH WIRE OR CABLE IS NOT INSTALLED SHALL REMAIN CAPPED OR PLUGGED.

BELL ENDS SHALL BE INSTALLED ON ALL PVC CONDUIT EXPOSED AT THE TOP OF CONCRETE BASES BEFORE INSTALLATION OF CABLE OR WIRE.

WHEN REQUIRED TO CONNECT NON-METALLIC CONDUIT TO METALLIC CONDUIT, ONLY ADAPTER FITTINGS, U.L. LISTED FOR ELECTRICAL USE, SHALL BE USED.

A NO. 4 AWG STRANDED COPPER EQUIPMENT GROUNDING CONDUCTOR SHALL BE EXOTHERMICALLY WELDED TO THE EQUIPMENT GROUNDING ELECTRODE (GROUND ROD).

THE EQUIPMENT GROUNDING CONDUCTOR SHALL BE FURNISHED AND INSTALLED TO ENTER THE BASE THROUGH A 1 INCH CONDUIT INSTALLED FOR GROUNDING PURPOSES, LEAVING A 4 FOOT COIL OF WIRE ABOVE THE CONCRETE BASE. THE EQUIPMENT GROUNDING CONDUCTOR SHALL BE NEATLY COILED AND THE COILS TIED TOGETHER.

THE FINAL OR TERMINATING CONCRETE BASE IN A CONDUIT RUN SHALL HAVE A 6" EXIT STUB INSTALLED FOR FUTURE CABLING USE. THE EXIT STUB SHALL BE SIZED AS USED THROUGHOUT THE CONDUIT RUN AS SHOWN A THE ENTRANCE OF THE BASE.

① THE MINIMUM DEPTH OF CONDUIT EXITING THE CONCRETE BASE AND INSTALLED BELOW THE TRAVELED WAY SHALL BE 24 INCHES. THE MINIMUM DEPTH OF CONDUIT EXITING THE CONCRETE BASE THAT IS NOT INSTALLED BELOW THE TRAVELED WAY SHALL BE 18 INCHES. THE MAXIMUM DEPTH OF ALL CONDUIT SHALL BE 36 INCHES (GREATER THAN 36 INCHES IF INSTALLED IN BREAKER RUN) EXCEPT WITH WRITTEN APPROVAL OF THE ENGINEER.

CONCRETE MASONRY.....fc = 3,500 p.s.i.
 HIGH STRENGTH BAR STEEL REINFORCEMENT, GRADE 60.....fy = 60,000 p.s.i.
 ANCHOR RODS, ASTM F1554 GRADE 55 (IN ACCORDANCE WITH SECTION 531.2.2 OF THE STANDARD SPECIFICATION).....fy = 55,000 p.s.i.
 TEMPLATES, ASTM A709, GRADE 36.....fy = 36,000 p.s.i.

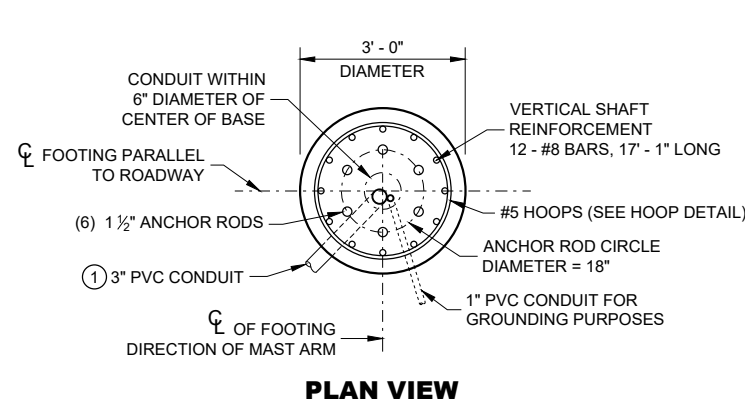

PLAN VIEW

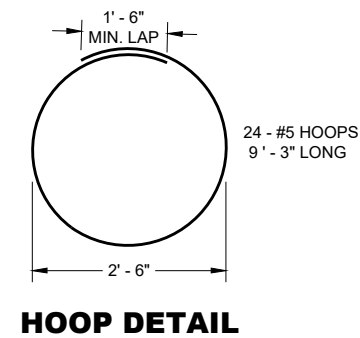

HOOP DETAIL

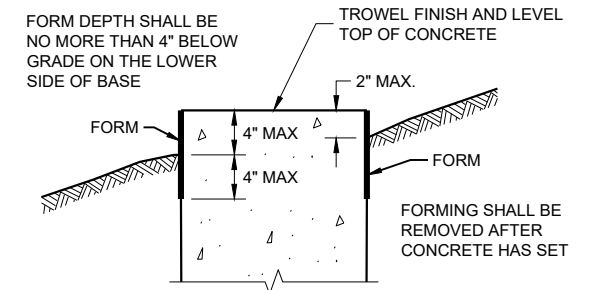

FORMING DETAIL

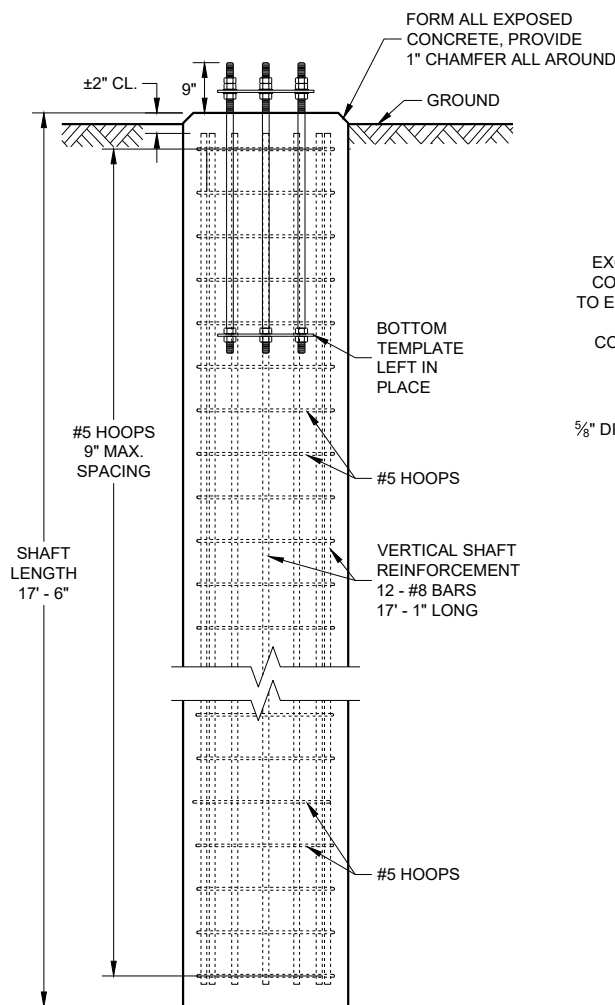

ELEVATION VIEW
(CONDUITS NOT SHOWN ON THIS VIEW FOR CLARITY)

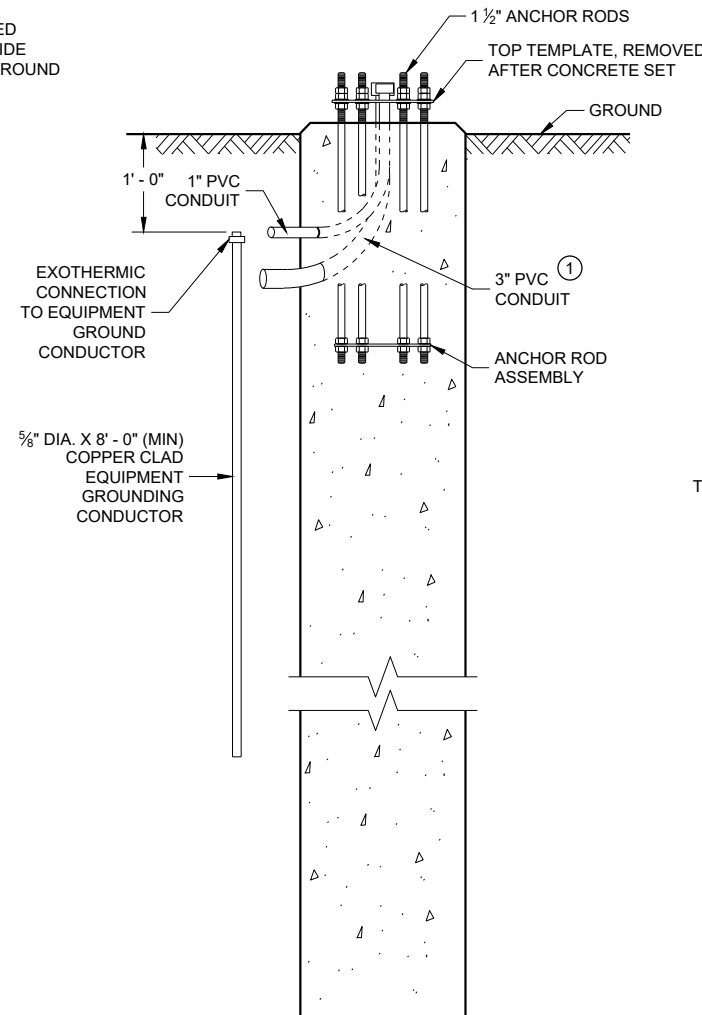

SIDE VIEW
(HOOPS AND VERTICAL SHAFT REINFORCEMENT NOT SHOWN ON THIS VIEW FOR CLARITY)

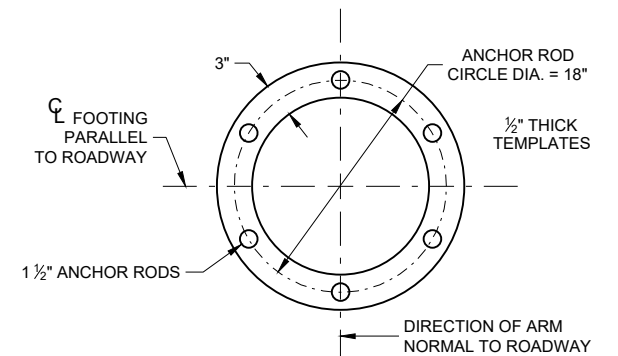

TOP AND BOTTOM TEMPLATE

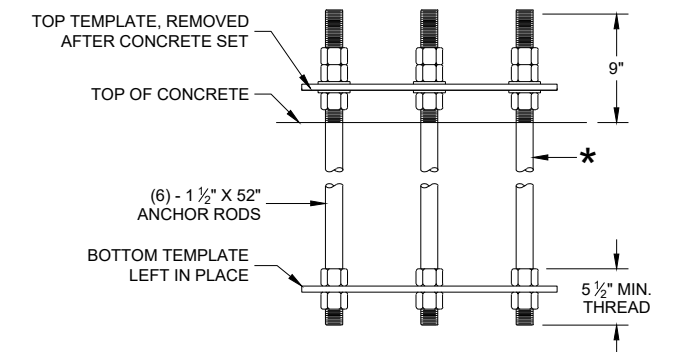

ANCHOR ROD ASSEMBLY DETAILS

* THREAD TOP 10" OF ANCHOR ROD FOR 3 NUTS AND 2 WASHERS AND BOTTOM 5 1/2" FOR 2 NUTS PER ANCHOR ROD. HOT DIP GALVANIZE THE ENTIRE LENGTH OF THE ANCHOR ROD (ASTM A123) AND HOT DIP NUTS AND WASHERS (ASTM A153. USE ZINC COATED NUTS MANUFACTURED WITH SUFFICIENT ALLOWANCE TO ALLOW NUTS TO RUN FREELY ON THE THREADS.

**CONCRETE BASE, TYPE 10 SPECIAL
(FOR TYPE 9 SPECIAL AND TYPE 10 SPECIAL POLES)**

CONCRETE = 4.6 CUBIC YARD
 H.S. REINFORCEMENT = 779 LBS.

FOR USE WHEN GROUND ELEVATION AT BASE EQUALS OR IS GREATER THAN HIGH POINT OF ROADWAY ELEVATION.

**CONCRETE BASE
TYPE 10 SPECIAL**

STATE OF WISCONSIN
 DEPARTMENT OF TRANSPORTATION

APPROVED
 August 2020 /S/ Alex Crabtree
 DATE WIND LOADED STRUCTURES PROGRAM LEADER
 FHWA

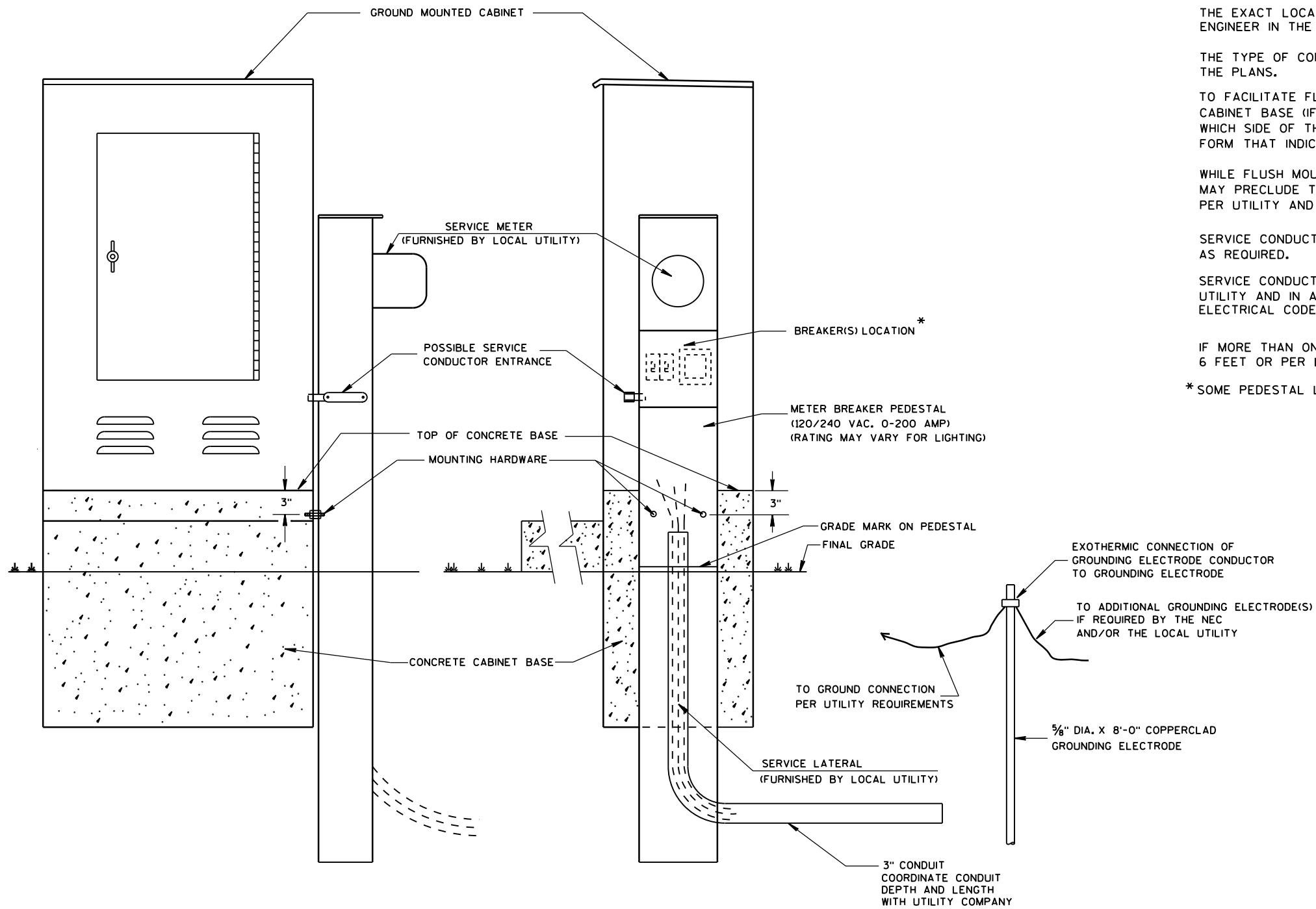

TYPICAL CABINET SERVICE INSTALLATION

GENERAL NOTES

DETAILS OF CONSTRUCTION, MATERIALS AND WORKMANSHIP NOT SHOWN ON THIS DRAWING SHALL CONFORM TO THE PERTINENT REQUIREMENTS OF THE CONTRACT.

THE EXACT LOCATION OF THE METER BREAKER PEDESTAL SHALL BE DETERMINED BY THE ENGINEER IN THE FIELD.

THE TYPE OF CONCRETE CABINET BASE TO BE INSTALLED SHALL BE AS CALLED FOR IN THE PLANS.

TO FACILITATE FLUSH MOUNTING OF THE METER BREAKER PEDESTAL AGAINST THE SIDE OF THE CABINET BASE (IF FLUSH MOUNTING POSSIBLE, CONFER WITH THE LOCAL UTILITY TO DETERMINE WHICH SIDE OF THE CONCRETE BASE THE ELECTRICAL SERVICE LATERAL WILL APPROACH, THEN FORM THAT INDICATED SIDE FOR FULL SIDE DEPTH.

WHILE FLUSH MOUNTING IS THE MOST DESIRABLE MOUNTING CONFIGURATION UTILITY REQUIREMENTS MAY PRECLUDE THIS OPTION. CONTRACTOR MUST PROVIDE UTILITY APPROVED PEDESTAL AND INSTALL PER UTILITY AND MANUFACTURERS REQUIREMENTS.

SERVICE CONDUCTOR ENTRANCES SHALL BE RIGID METALLIC CONDUIT, NIPPLES AND/OR CONDULETS AS REQUIRED.

SERVICE CONDUCTOR ENTRANCES SHALL BE SIZED AND LOCATED AS REQUIRED BY THE LOCAL UTILITY AND IN ACCORDANCE WITH APPROPRIATE ARTICLES OF THE LATEST ACCEPTED NATIONAL ELECTRICAL CODE.

IF MORE THAN ONE GROUNDING ELECTRODE IS REQUIRED, THE DISTANCE APART SHALL BE 6 FEET OR PER LOCAL UTILITY REGULATIONS.

* SOME PEDESTAL LIGHTING PLANS SHOW MAIN LUGS ONLY.

CABINET SERVICE INSTALLATION (METER BREAKER PEDESTAL)	
STATE OF WISCONSIN DEPARTMENT OF TRANSPORTATION	
APPROVED DATE FHWA	/S/ Ahmet Demirbilek STATE ELECTRICAL ENGINEER

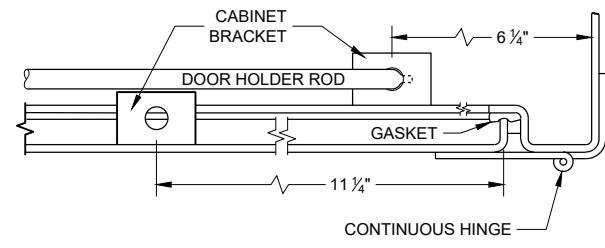
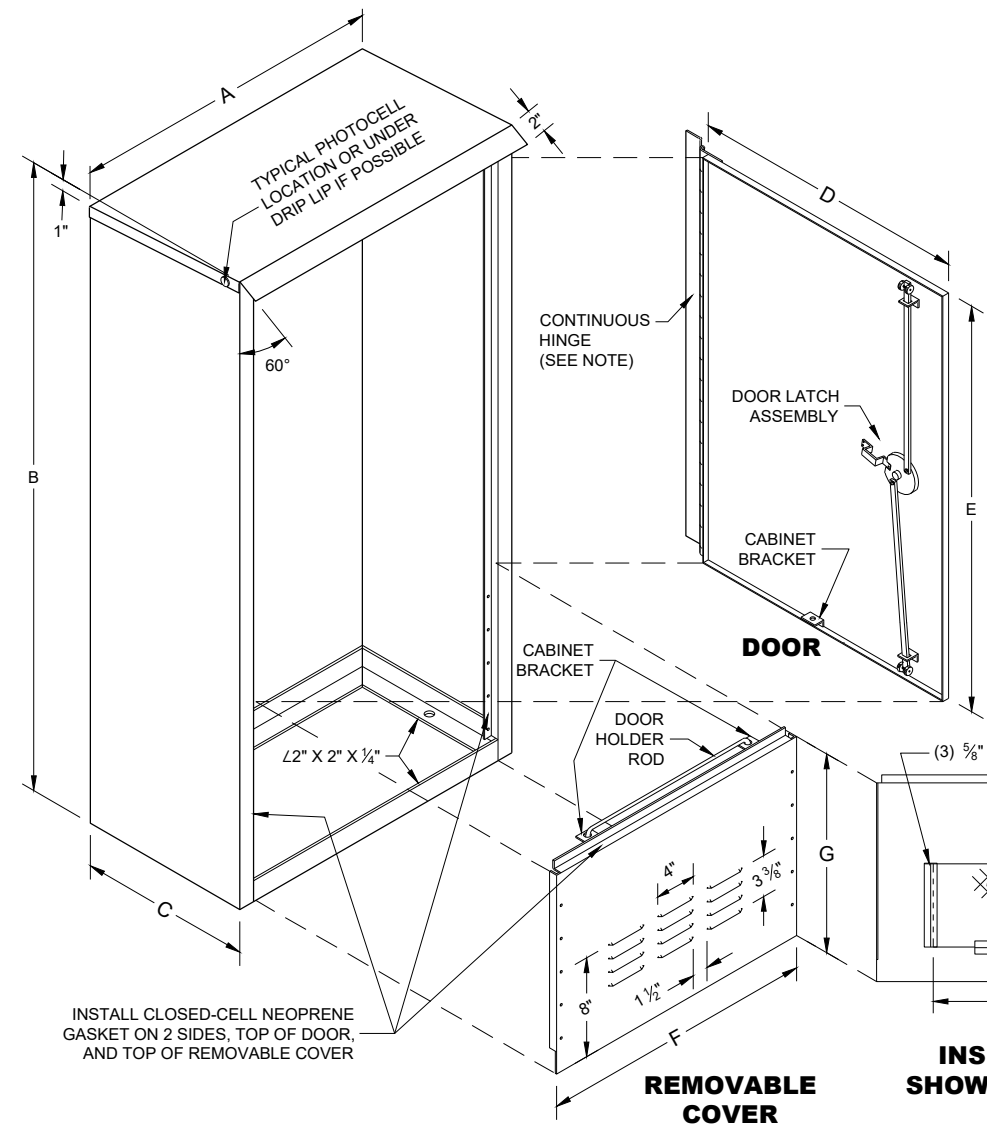

HINGE AND DOOR HOLDER

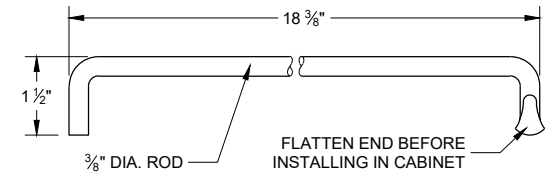

HOLDER ROD

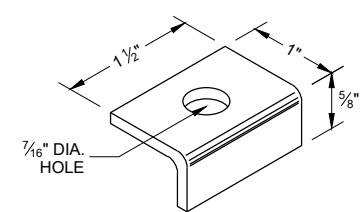

CABINET BRACKET

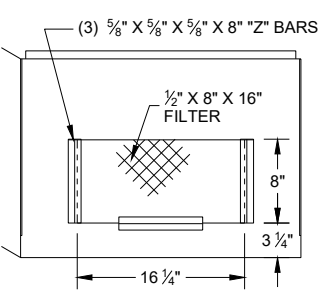

INSIDE VIEW SHOWING FILTER

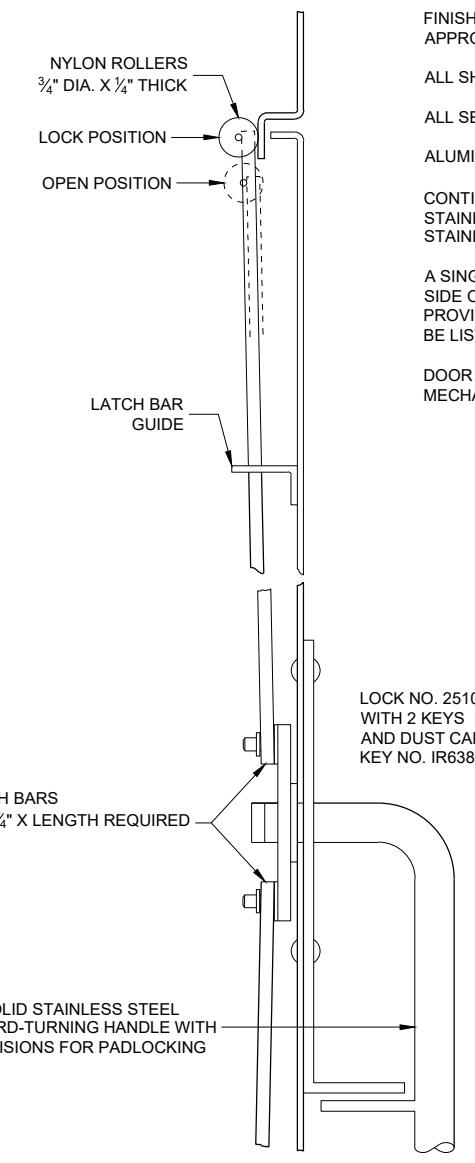

SIDE VIEW

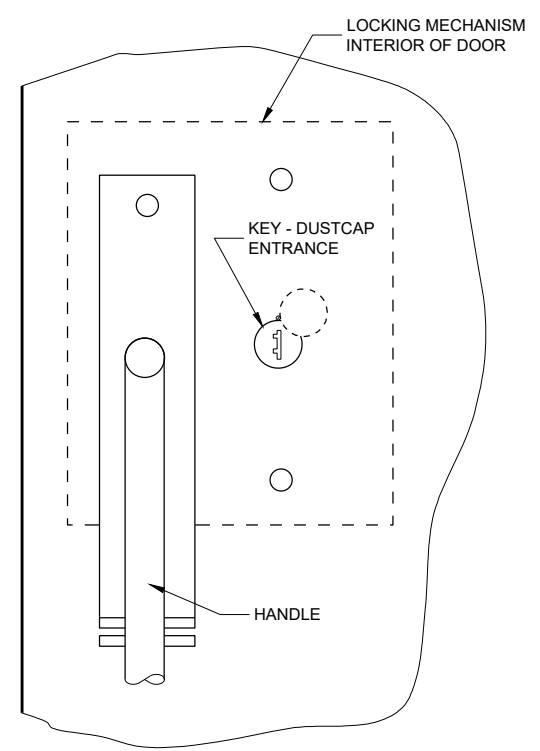

FRONT VIEW

LATCH ASSEMBLY

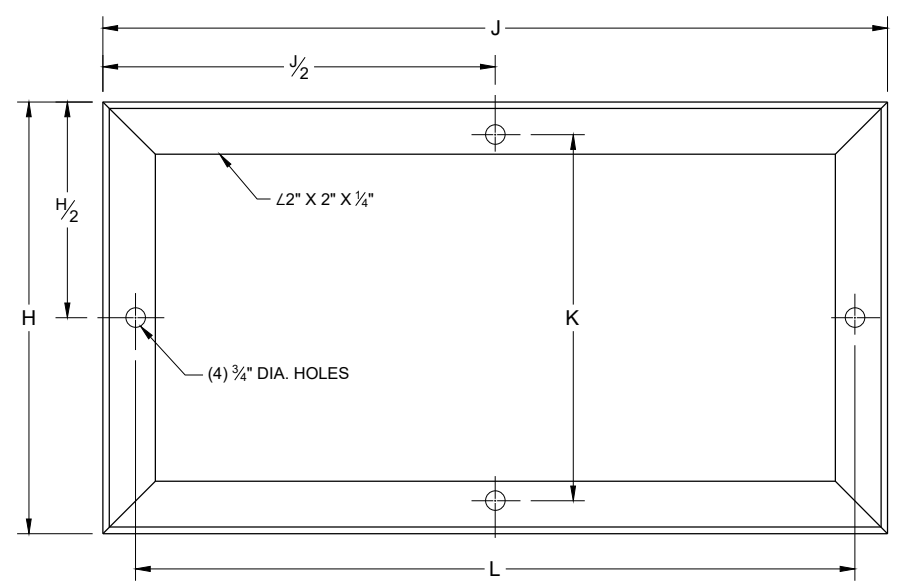

MOUNTING BASE

TABLE OF DIMENSIONS (INCHES)

MARK	CABINET TYPE		
	3060	3860	3866
A	30	38	38
B	60	60	66
C	16 1/2	16 1/2	24
D	26 1/2	34 3/4	33 3/4
E	38 3/4	38 3/4	38 3/4
F	26 1/2	34 3/4	33 3/4
G	19	19	25
H	16 1/2	16 1/2	24
H/2	8 3/4	8 3/4	12
J	30	38	38
J/2	15	19	19
K	13 3/4	13 3/4	21 1/4
L	27 1/2	35 1/2	35 1/2

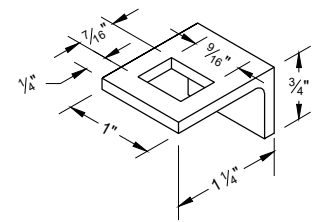

LATCH BAR GUIDE

GENERAL NOTES

DETAILS OF CONSTRUCTION, MATERIALS AND WORKMANSHIP NOT SHOWN ON THIS DRAWING SHALL CONFORM TO THE PERTINENT REQUIREMENTS OF THE STANDARD SPECIFICATIONS AND APPLICABLE SPECIAL PROVISIONS.

PRIME WITH PHOSPHATE TREATMENT AND PRIMER.

FINISH EXTERIOR SURFACES WITH RUSTOLEUM #906 SILVER GRAY OR APPROVED EQUAL.

FINISH INTERIOR WITH RUSTOLEUM #2766 HIGH GLOSS WHITE ENAMEL OR APPROVED EQUAL.

ALL SHEET METAL PARTS SHALL BE .125 INCH THICK ALUMINUM.

ALL SEAMS SHALL BE CONTINUOUSLY WELDED.

ALUMINUM SHALL BE TYPE 5052-H32.

CONTINUOUS HINGE SHALL BE HEAVY GAUGE ALUMINUM WITH 1/2" DIAMETER STAINLESS STEEL HINGE PIN. HINGE IS SECURED WITH 1/2" X 20 TPI STAINLESS STEEL CARRIAGE BOLTS AND STAINLESS STEEL NYLOCK NUTS.

A SINGLE PHOTOCELL SHALL BE LOCATED ON THE NORTH - NORTHEAST SIDE OF THE CABINET UNLESS OTHERWISE CALLED FOR IN THE SPECIAL PROVISIONS. THE PHOTOCELL SHALL BE PLACED AS SHOWN AND SHALL BE LISTED ON THE DEPARTMENTS APPROVED PRODUCTS LIST.

DOOR LATCH ASSEMBLY TO BE PROVIDED WITH THREE-POINT LOCKING MECHANISM.

6

6

SDD 09D02 - 03

SDD 09D02 - 03

SIGNAL CONTROL CABINET

STATE OF WISCONSIN
DEPARTMENT OF TRANSPORTATION

APPROVED
September 2014 /S/ Ahmet Demerbilek
DATE STATE ELECTRICAL ENGINEER
FHWA

FRONT INTERIOR ELEVATION

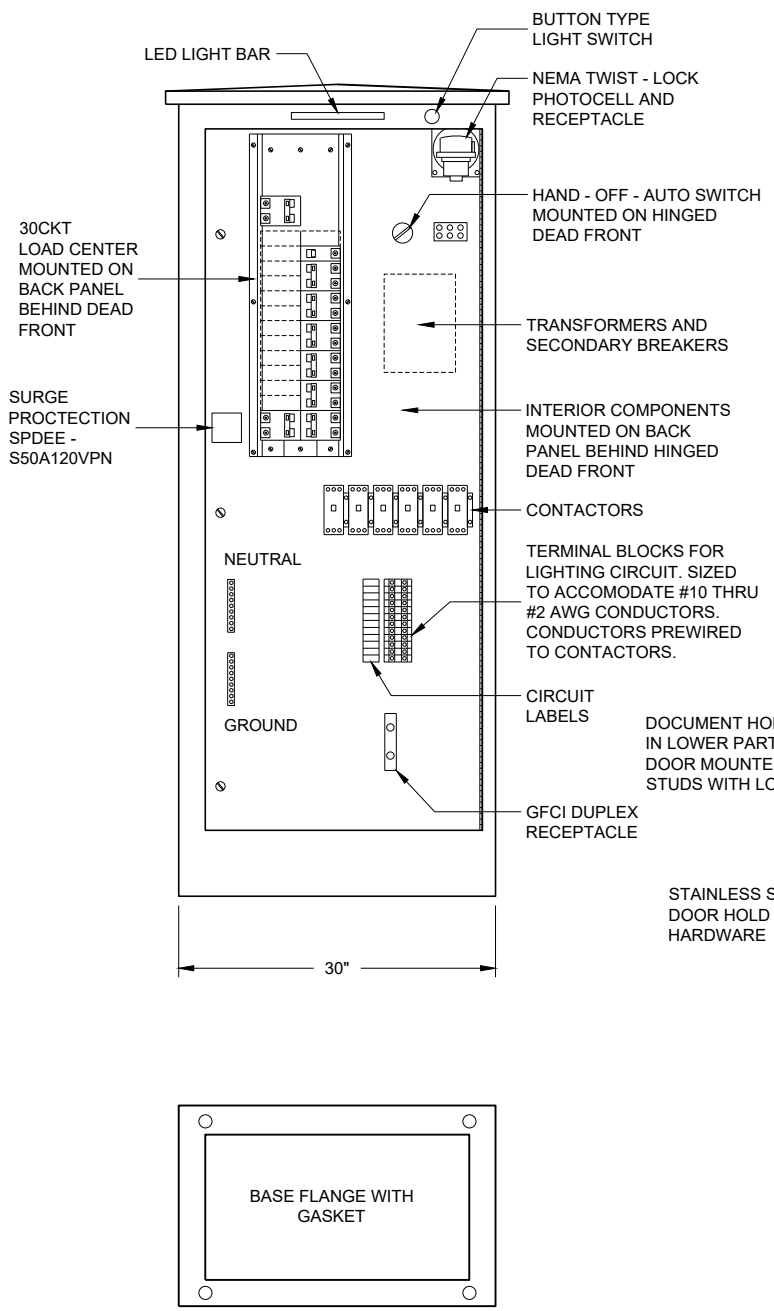

SIDE VIEW

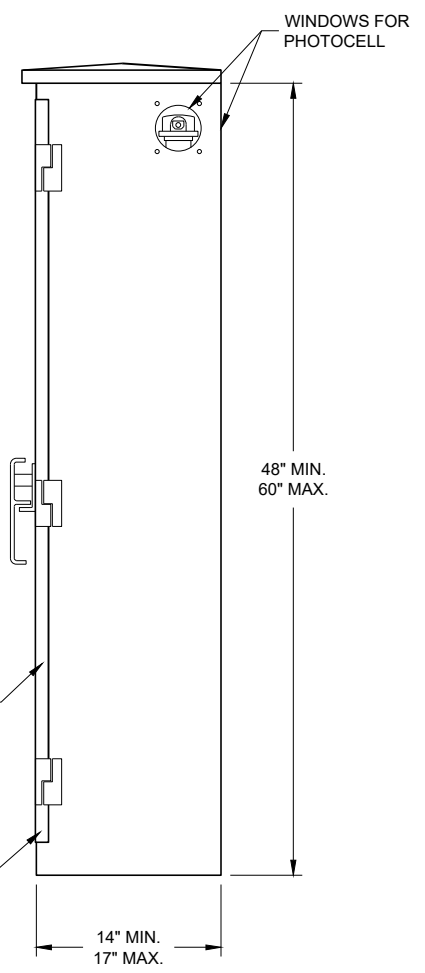

LIGHTING CONTROL CABINET

UTILITY METER PEDESTAL PROVIDED BY CONTRACTOR UNDER SEPARATE BID ITEM. MAY OR MAY NOT BE ATTACHED TO OUTSIDE OF CONTROL CABINET PER PROJECT REQUIREMENTS.

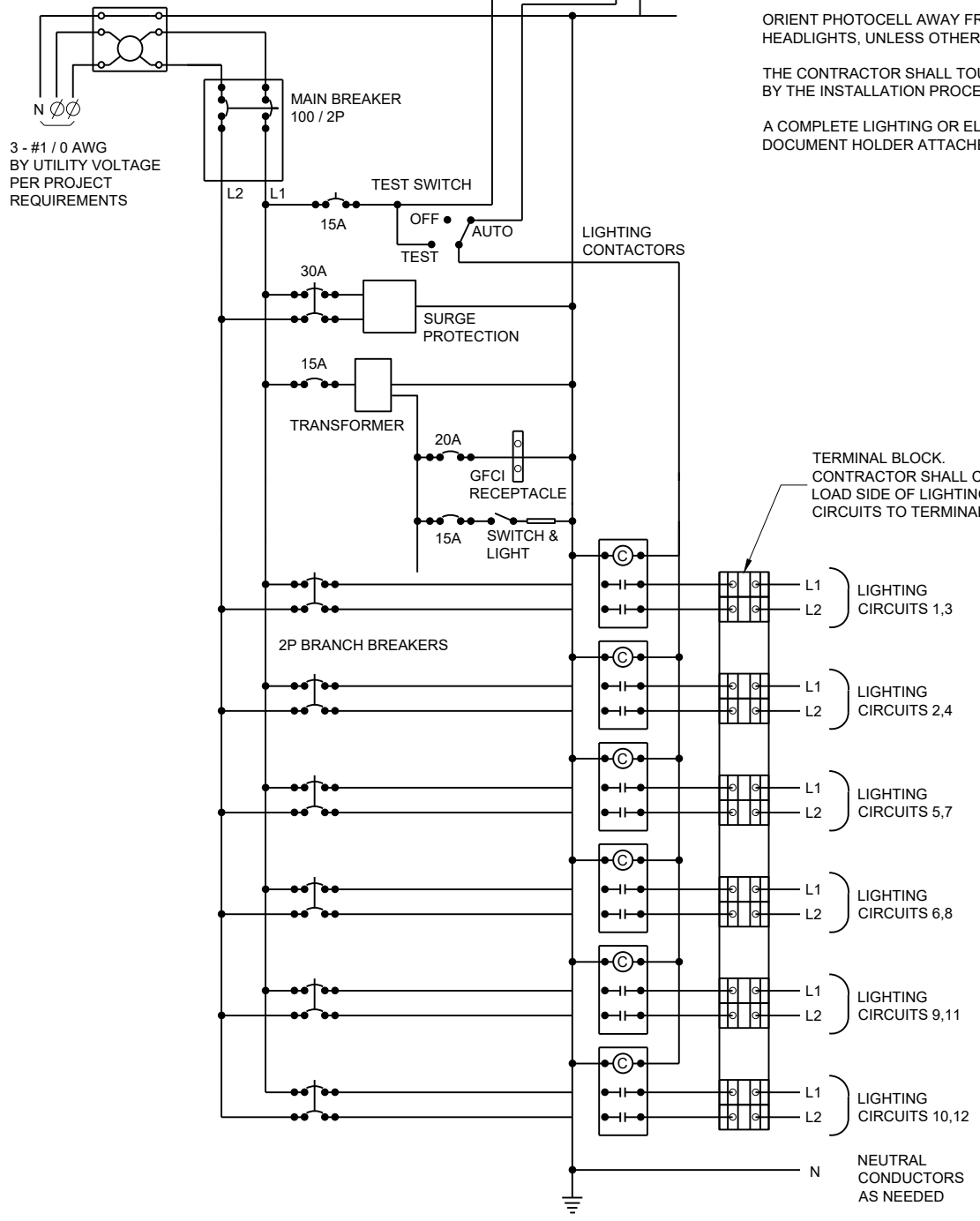

CONTROL CABINET SCHEMATIC

GENERAL NOTES

DETAILS OF CONSTRUCTION, MATERIALS AND WORKMANSHIP NOT SHOWN ON THIS DRAWING SHALL CONFORM TO THE PERTINENT REQUIREMENTS OF THE STANDARD SPECIFICATIONS AND APPLICABLE SPECIAL PROVISIONS.

ALL INTERNAL ELECTRICAL COMPONENTS WILL BE PRE - WIRED BY THE CABINET MANUFACTURER.

ALL CONDUIT ENTRIES SHALL BE SEALED WITH AN APPROPRIATE DUCT SEALING COMPOUND.

ORIENT PHOTOCELL AWAY FROM AMBIENT LIGHT SOURCES AND ONCOMING TRAFFIC HEADLIGHTS, UNLESS OTHERWISE CALLED FOR IN THE SPECIAL PROVISION.

THE CONTRACTOR SHALL TOUCH UP ANY DAMAGE TO THE ANODIZED FINISH CAUSED BY THE INSTALLATION PROCESS. COLOR MATCH PAINT SHALL BE USED.

A COMPLETE LIGHTING OR ELECTRICAL PLAN SHALL BE SECURELY PLACED IN THE DOCUMENT HOLDER ATTACHED TO THE DOOR.

6

6

SDD 09D05 - 02

SDD 09D05 - 02

L30
LIGHTING CONTROL CABINET
240 / 480 VOLT

STATE OF WISCONSIN
DEPARTMENT OF TRANSPORTATION

APPROVED
November 2018 /S/ Ahmet Demirelek
DATE STATE ELECTRICAL ENGINEER
FHWA

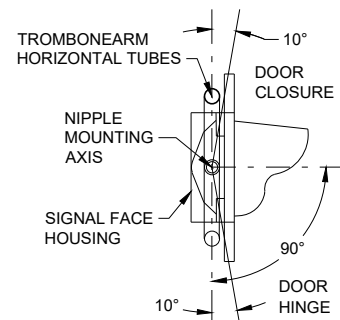

SECTION A-A

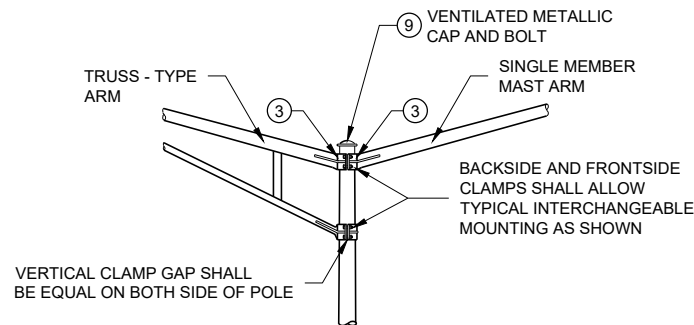
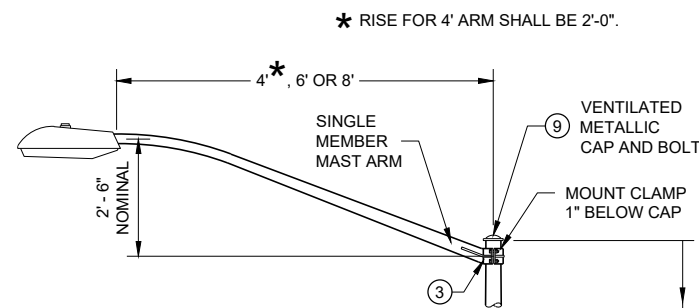

INTERCHANGEABLE MOUNTING DETAIL

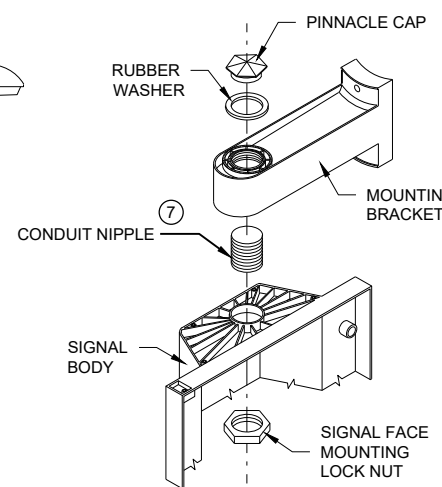
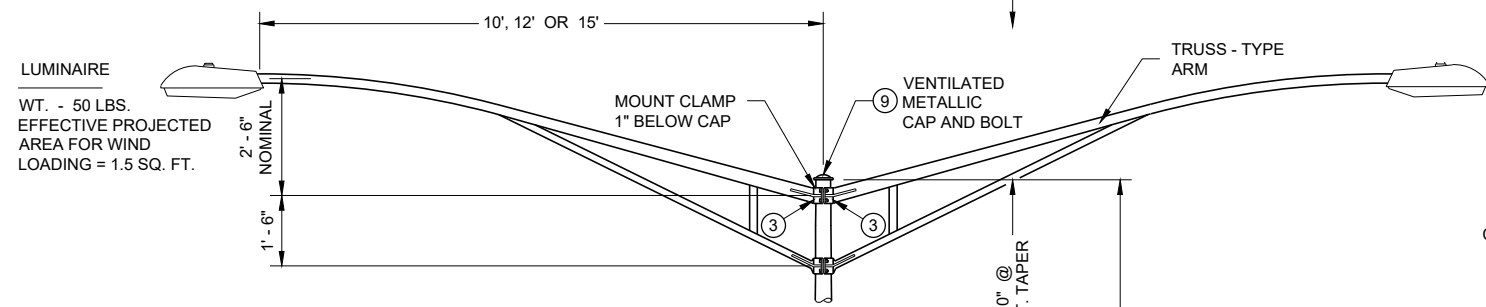

SIGNAL FACE MOUNTING DETAIL (BANDED)

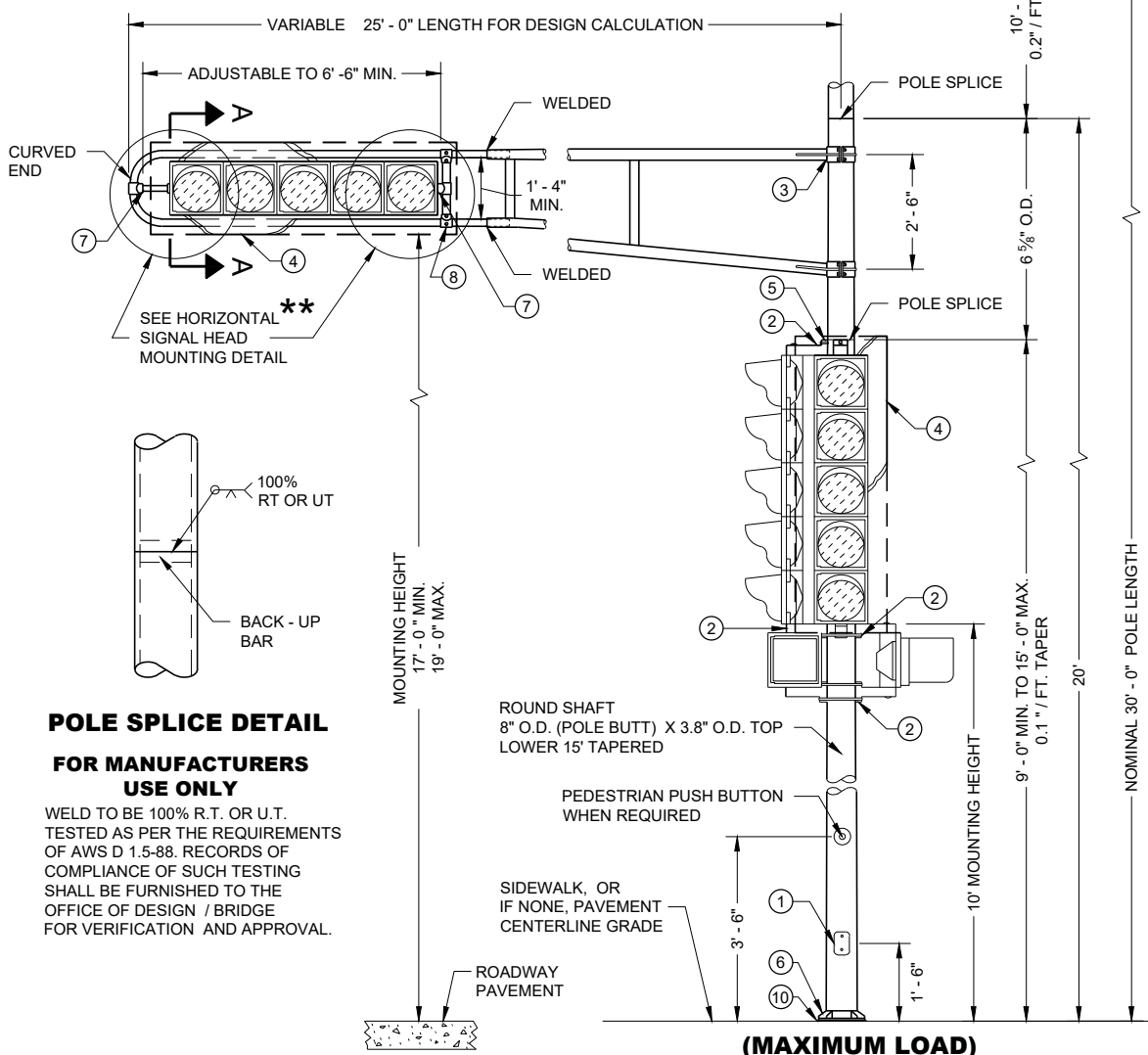

POLE SPLICE DETAIL FOR MANUFACTURERS USE ONLY

WELD TO BE 100% R.T. OR U.T. TESTED AS PER THE REQUIREMENTS OF AWS D 1.5-88. RECORDS OF COMPLIANCE OF SUCH TESTING SHALL BE FURNISHED TO THE OFFICE OF DESIGN / BRIDGE FOR VERIFICATION AND APPROVAL.

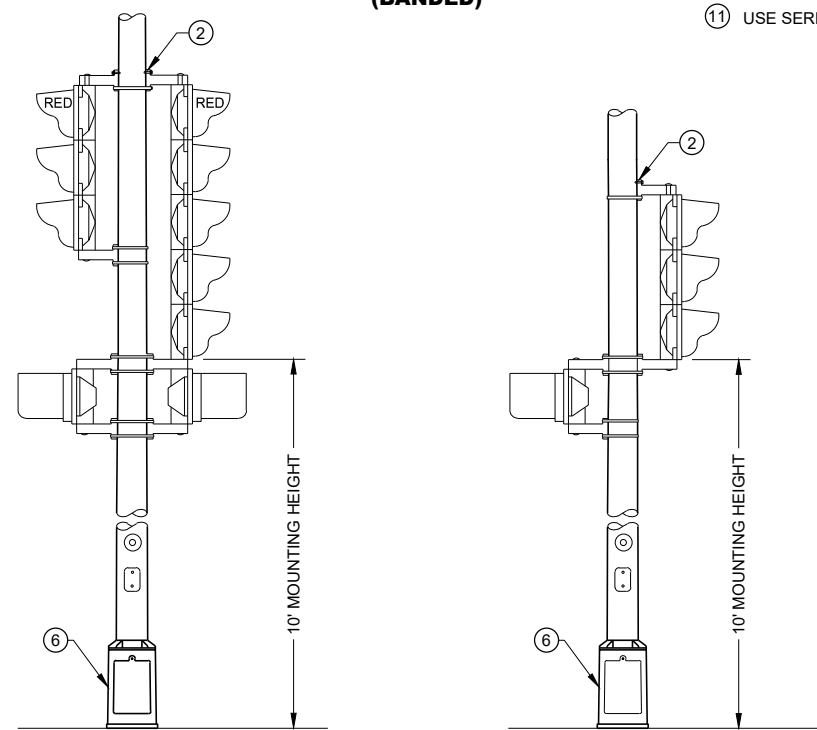

TYPICAL MOUNTING OF BACK TO BACK 3 AND 5 SECTION SIGNAL FACES

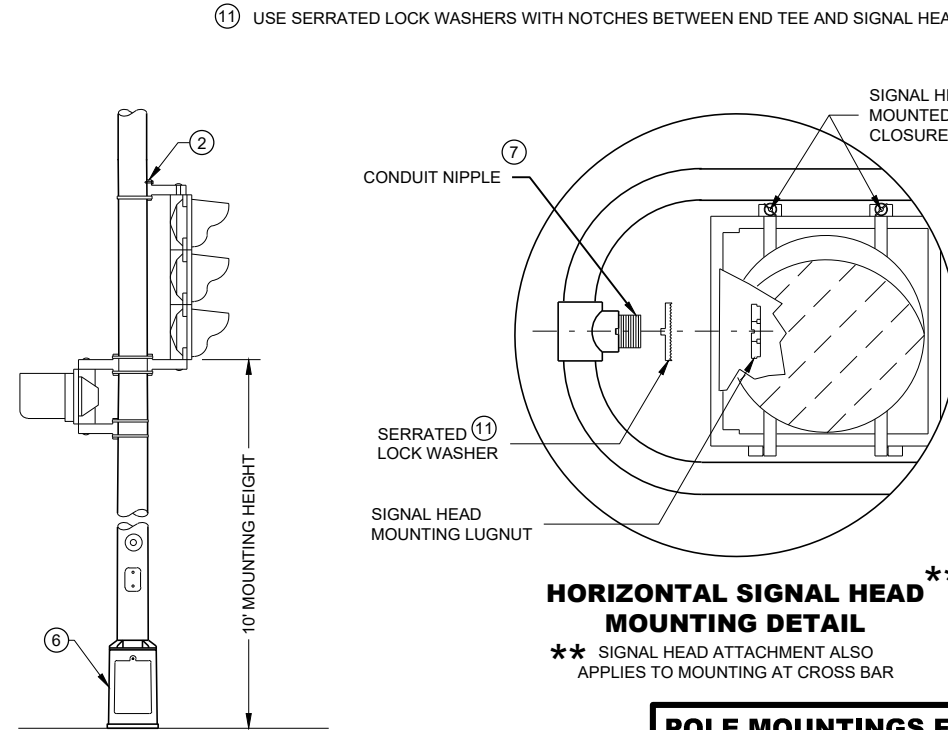

TYPICAL MOUNTING OF 3 SECTION SIGNAL FACE

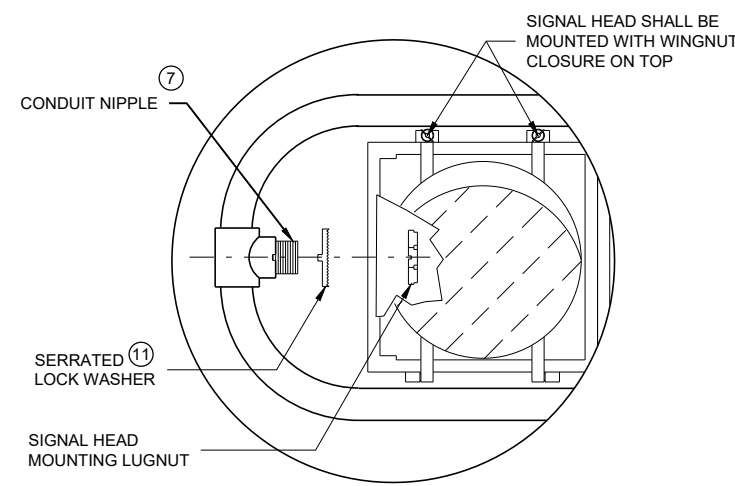

HORIZONTAL SIGNAL HEAD MOUNTING DETAIL

** SIGNAL HEAD ATTACHMENT ALSO APPLIES TO MOUNTING AT CROSS BAR

GENERAL NOTES

DETAILS OF CONSTRUCTION, MATERIALS AND WORKMANSHIP NOT SHOWN ON THIS DRAWING SHALL CONFORM TO THE PERTINENT REQUIREMENTS OF THE CONTRACT.

ALL TYPE 3 POLE MOUNTINGS SHALL BE DESIGNED TO INCLUDE TWIN 15' ARMS WITH LUMINAIRES.

POLES SHALL BE GALVANIZED STEEL.

SECTION 657, POLES, OF THE STANDARD SPECIFICATIONS SHALL APPLY TO THIS DRAWING.

A PULL WIRE / ROPE SHALL BE INSTALLED IN EACH TROMBONE ARM RACEWAY DURING THE MANUFACTURING PROCESS.

THE SLIPFITTER END OF THE LUMINAIRE MAST ARM SHALL BE A NOMINAL 2 3/8 INCHES IN OUTSIDE DIAMETER. THE STRAIGHT PORTION OF THE SLIPFITTER END OF THE LUMINAIRE MAST ARM SHALL BE A NOMINAL 12 INCHES IN LENGTH.

WHEN TRANSFORMER BASES ARE USED, WIRE CONNECTIONS SHALL BE MADE IN THE TRANSFORMER BASE.

- ① 4" X 6" REINFORCED HANDHOLE AND COVER ASSEMBLY WITH TWO (2) 1/2" X 3/4" - 20 TPI, STAINLESS STEEL, HEX HEAD BOLTS.
- ② SIGNAL FACE MOUNTING BRACKETS. MOUNT WITH CAP SCREWS AND BANDING.
- ③ GROMMETS. 1" CHASE NIPPLES OR 1" CLOSE CONDUIT NIPPLES WITH BUSHINGS SHALL BE PROVIDED FOR 1 1/2" HOLE IN POLE SHAFT FOR WIRING.
- ④ SECURELY MOUNT DULL BLACK POLYCARBONATE BACKPLATES, PROJECTING 5" BEYOND ALL SIDES OF THE SIGNAL FACE HOUSING, PER MANUFACTURER'S RECOMMENDATIONS.
- ⑤ POLE MOUNTED SIGNAL FACES SHALL REQUIRE ONE OR MORE MOUNTING SPACERS UNDER THE TOP MOUNTING BRACKET(S) AS REQUIRED, TO PLUMB THE SIGNAL FACE.
- ⑥ CAST ALUMINUM TRANSFORMER BASE, WHEN REQUIRED. UNDER MAX LOADING, TYPE 3 POLE SHALL BE MOUNTED DIRECTLY TO ITS CONCRETE BASE.
- ⑦ USE 1 1/2" ID NIPPLES ZINC-COATED RIGID METAL CONDUIT, LONG ENOUGH TO ACCOMMODATE FULL DEPTH THREADING INTO THE HEAD MOUNTING LOCK NUT IN ORDER TO TIGHTEN THE FACE, BUT THAT DO NOT INTERFERE WITH REFLECTOR CLOSURE. THREAD THE NIPPLE INTO THE MOUNTING BRACKET/ELBOW UNTIL TIGHT. USE APPROVED PINNACLE TYPE HARDWARE FROM A DEPARTMENT APPROVED MANUFACTURER TO CLOSE THE UNUSED 1 1/2" OPENING IN SIGNAL FACES AND BRACKET ENDS.
- ⑧ VERTICAL STRUT (ADJUSTABLE), ONE (1) SET SCREW (1/2" X 3/4" - 20 TPI STAINLESS STEEL, HEX HEAD) INTO EACH ARM MEMBER IF STRUT IS THE SLIDING TYPE.
- ⑨ FURNISH AND INSTALL VENTILATED, CAST METALLIC (ALUMINUM ALLOY) CAPS. FASTEN CAPS WITH ONE (1) 1/2" X 3/4" - 20 TPI STAINLESS STEEL, HEX HEAD BOLT.
- ⑩ SHIMMING, IF NEEDED, SHALL BE LOCATED BETWEEN THE CONCRETE FOUNDATION AND POLE.
- ⑪ USE SERRATED LOCK WASHERS WITH NOTCHES BETWEEN END TEE AND SIGNAL HEAD.

TYPE 3 POLE MOUNTING CONFIGURATION

POLE MOUNTINGS FOR TRAFFIC SIGNALS AND LIGHTING UNITS TYPE 3 (HEAVY DUTY)

STATE OF WISCONSIN DEPARTMENT OF TRANSPORTATION

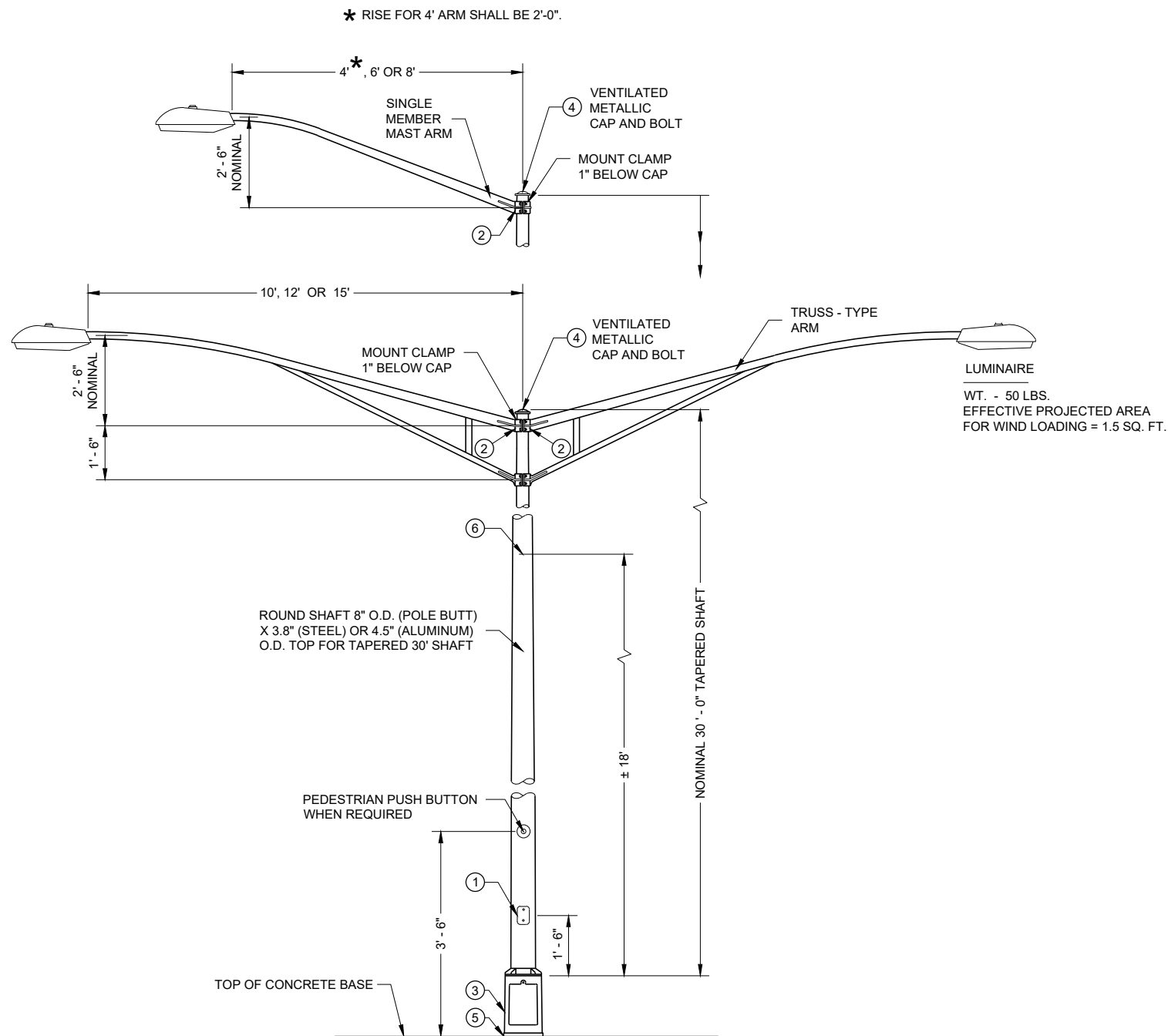

**TYPE 5 POLE MOUNTING CONFIGURATION
(MAXIMUM LOAD)
LIGHTING ONLY**

GENERAL NOTES

DETAILS OF CONSTRUCTION, MATERIALS AND WORKMANSHIP NOT SHOWN ON THIS DRAWING SHALL CONFORM TO THE PERTINENT REQUIREMENTS OF THE CONTRACT.

SECTION 657, POLES, OF THE STANDARD SPECIFICATIONS SHALL APPLY TO THIS DRAWING.

ALL TYPE 5 POLE MOUNTINGS SHALL BE DESIGNED TO INCLUDE TWIN 15' ARMS WITH LUMINAIRES.

POLES SHALL BE GALVANIZED STEEL OR ALUMINUM, AS CALLED FOR IN THE CONTRACT.

TYPE 5 ALUMINUM POLES SHALL BE CONSTRUCTED OF 6063 - T6 ALUMINUM ALLOY. SLEEVING INSIDE THE POLE IS NOT ACCEPTABLE.

TYPE 5 ALUMINUM POLES SHALL HAVE A MINIMUM WALL THICKNESS OF 0.1888".

TYPE 5 STEEL POLES SHALL HAVE A MINIMUM WALL THICKNESS OF U.S. STANDARD 11 GAGE (0.1196").

THE SLIPFITTER END OF THE LUMINAIRE MAST ARM SHALL BE A NOMINAL 2 3/8 INCHES IN OUTSIDE DIAMETER. THE STRAIGHT PORTION OF THE SLIPFITTER END OF THE LUMINAIRE MAST ARM SHALL BE A NOMINAL 12 INCHES IN LENGTH.

WHEN TRANSFORMER BASES ARE USED, WIRE CONNECTIONS SHALL BE MADE IN THE TRANSFORMER BASE.

- ① 4" X 6" REINFORCED HANDHOLE AND COVER ASSEMBLY WITH TWO (2) 1/4" X 3/4" - 20 TPI , STAINLESS STEEL, HEX HEAD BOLTS.
- ② GROMMETS. 1" CHASE NIPPLES OR 1" CLOSE CONDUIT NIPPLES WITH BUSHINGS SHALL BE PROVIDED FOR 1 3/8" HOLE IN POLE SHAFT FOR WIRING.
- ③ CAST ALUMINUM TRANSFORMER BASE, WHEN REQUIRED.
- ④ FURNISH AND INSTALL VENTILATED, CAST METALLIC (ALUMINUM ALLOY) CAPS. FASTEN CAPS WITH ONE (1) 1/4" X 3/4" - 20 TPI STAINLESS STEEL, HEX HEAD BOLT.
- ⑤ SHIMMING, IF NEEDED, SHALL BE LOCATED BETWEEN THE CONCRETE FOUNDATION AND POLE.
- ⑥ INTERNAL DUMBBELL - TYPE VIBRATION DAMPER.

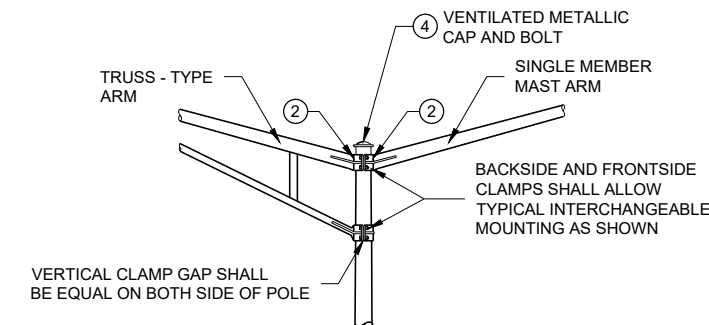

INTERCHANGEABLE MOUNTING DETAIL

**POLE MOUNTINGS FOR
LIGHTING UNITS, TYPE 5
(30 FEET)**

STATE OF WISCONSIN
DEPARTMENT OF TRANSPORTATION

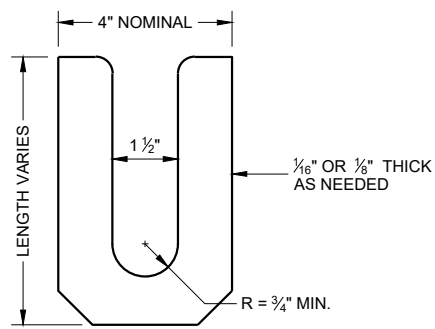

LEVELING SHIM
SHALL BE ALUMINUM

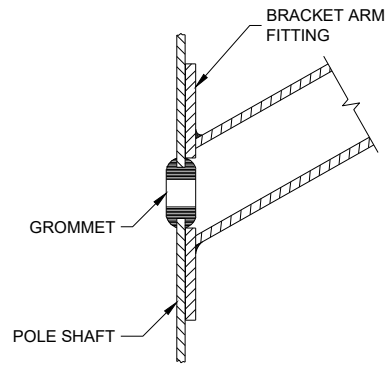

TYPICAL APPLICATION OF GROMMET IN POLE SHAFT

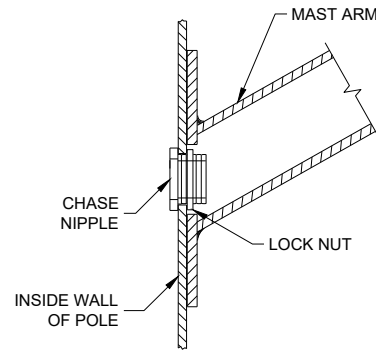

TYPICAL APPLICATION OF CHASE NIPPLE IN POLE SHAFT

GENERAL NOTES

CLAMP BOLT-NUT TIGHTENING TORQUE SHALL BE INDICATED BY INDENT STAMPING (1/2 INCH NUMERALS AND LETTERS) OR WEATHERPROOF PRINTING ON THE INSIDE OF THE CLAMP THAT IS WELDED TO THE ARM MEMBER.

- ① 4.5" I.D. FOR LUMINAIRE MAST ARM CLAMP. 6.625" I.D. FOR TROMBONE MAST ARM CLAMP.
- ② INDIVIDUAL BASE PLATE ANCHOR ROD COVERS. (4 REQUIRED)
- ③ BASE PLATE SLOTTED TO ACCEPT 11" THROUGH 12" BOLT CIRCLE USING 1" DIAMETER ANCHOR RODS.
- ④ LEVELING SHIMS, DESIGNED FOR THE PURPOSE, SHALL BE USED WHEN PLUMBING POLES. THE USE OF WASHERS IN LIEU OF PROPER LEVELING SHIMS IS NOT ACCEPTABLE. LEVELING SHIMS SHALL BE USED ONLY BETWEEN THE TOP OF THE CONCRETE BASE AND A METALLIC BASE PLATE.

SHIMS SHALL BE LONG ENOUGH AND WIDE ENOUGH TO COMPLETELY COVER THE AREA UNDER THE LENGTH AND WIDTH OF THE BASE MOUNTING FLANGE.

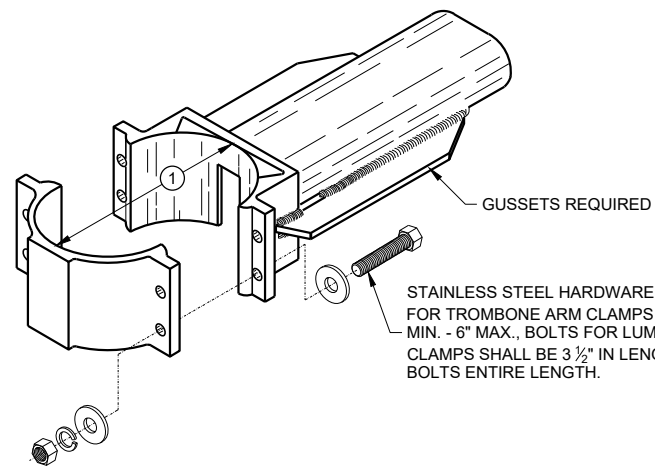

TYPICAL TROMBONE MAST ARM AND SINGLE LUMINAIRE MAST ARM MOUNTING CLAMP

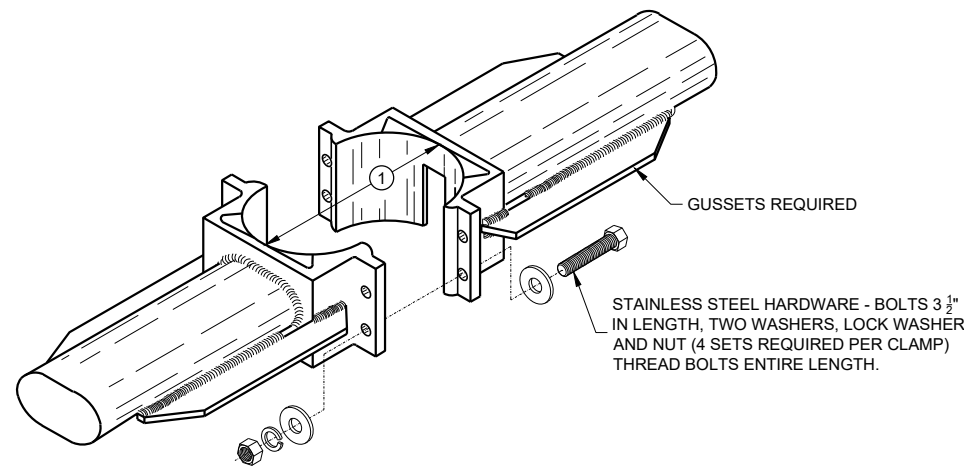

TYPICAL LUMINAIRE MAST ARM (DOUBLE) MOUNTING BRACKETS

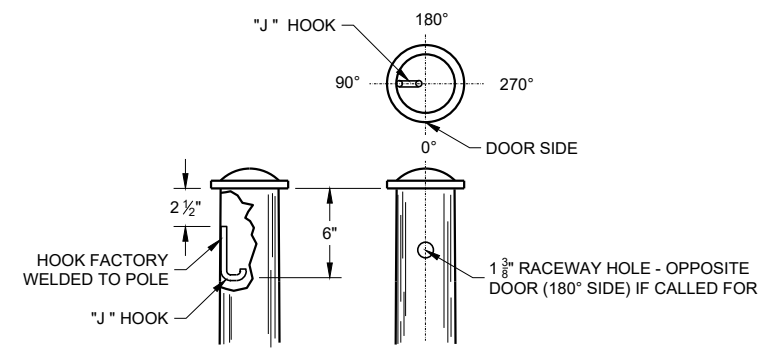

TYPICAL "J" HOOK LOCATION

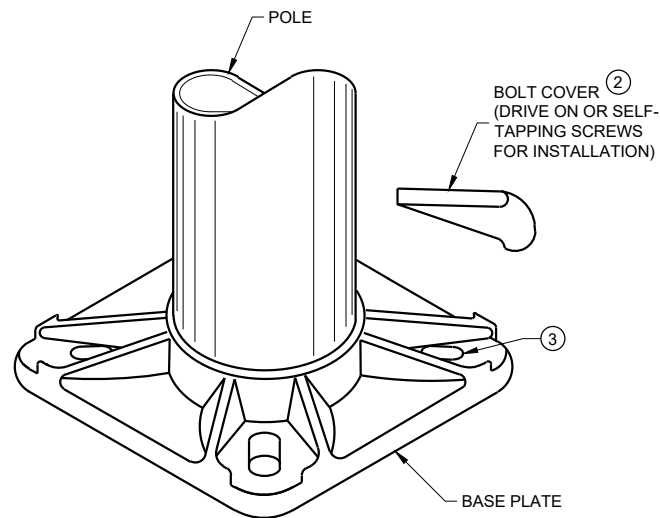

BASE PLATE

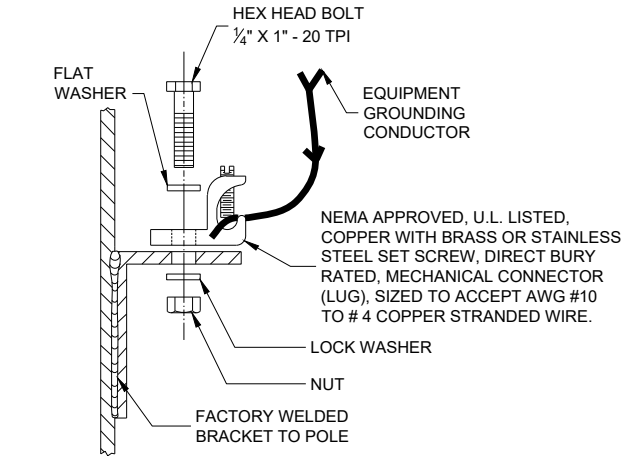
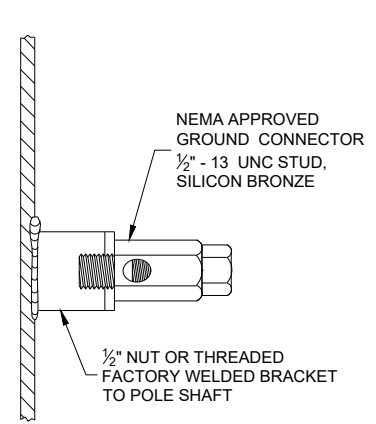

TYPICAL GROUNDING CONNECTIONS
NUT, BOLT AND WASHERS SHALL BE STAINLESS STEEL

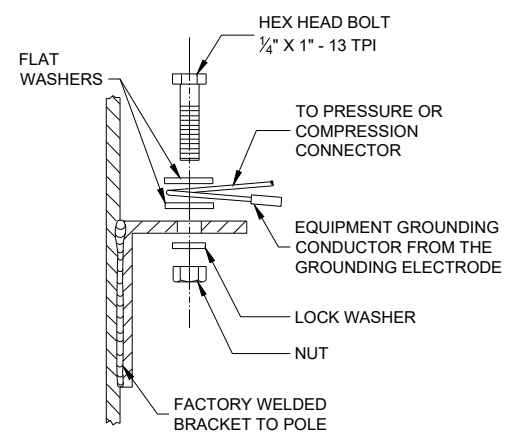

HARDWARE DETAILS FOR POLE MOUNTING

STATE OF WISCONSIN
DEPARTMENT OF TRANSPORTATION

APPROVED
November 2018 /S/ Ahmet Demirbilek
DATE STATE ELECTRICAL ENGINEER

GENERAL NOTES

DETAILS OF CONSTRUCTION, MATERIALS AND WORKMANSHIP NOT SHOWN ON THIS DRAWING SHALL CONFORM TO THE PERTINENT REQUIREMENTS OF THE CONTRACT.

THE EQUIPMENT GROUND CONNECTOR SHALL BE TAPED WITH 3 WRAPS (MINIMUM) OF APPROVED RUBBER TAPE AND 3 WRAPS (MINIMUM) OF APPROVED VINYL TAPE TO COVER SHARP WIRE ENDS AFTER THE CONNECTION IS COMPLETED.

WHEN TRANSFORMER BASES ARE USED, ALL WIRING CONNECTIONS SHALL OCCUR WITHIN THE TRANSFORMER BASES.

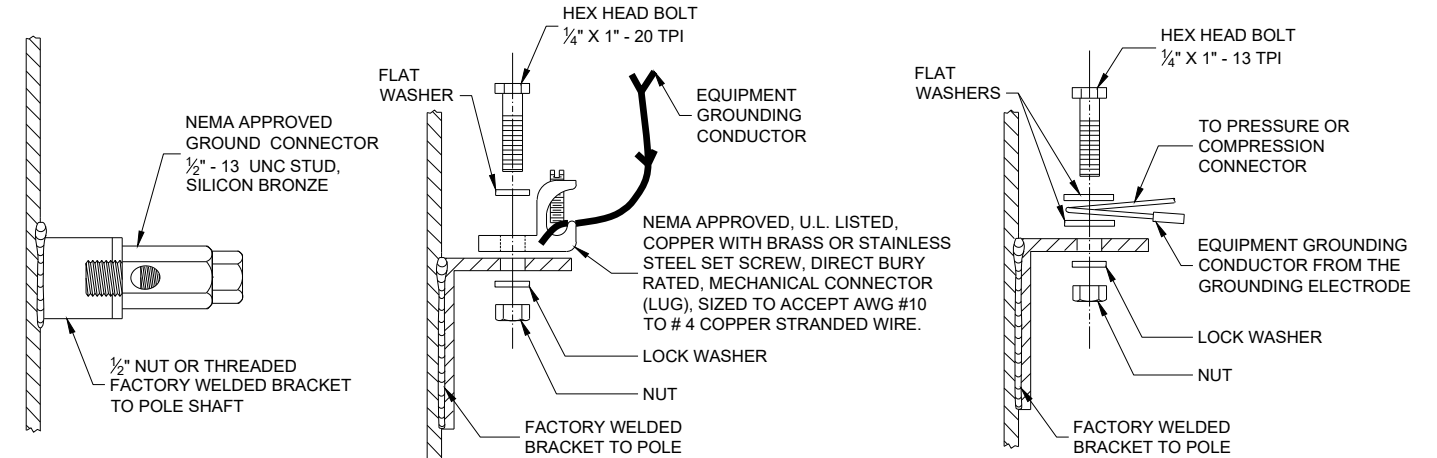
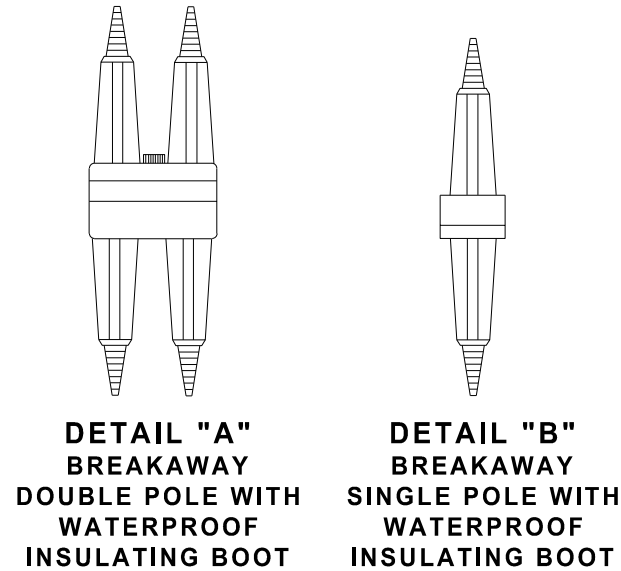
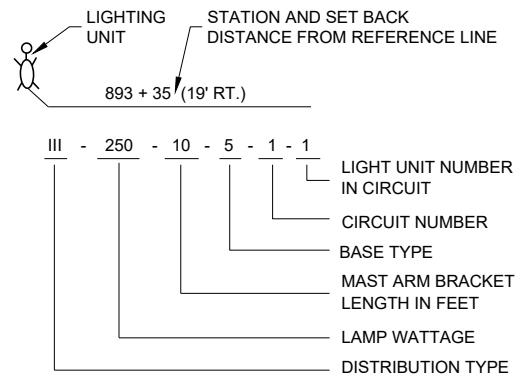

TYPICAL GROUNDING CONNECTIONS
NUT, BOLT AND WASHERS SHALL BE STAINLESS STEEL

LIGHTING UNIT CODE (TYPICAL)

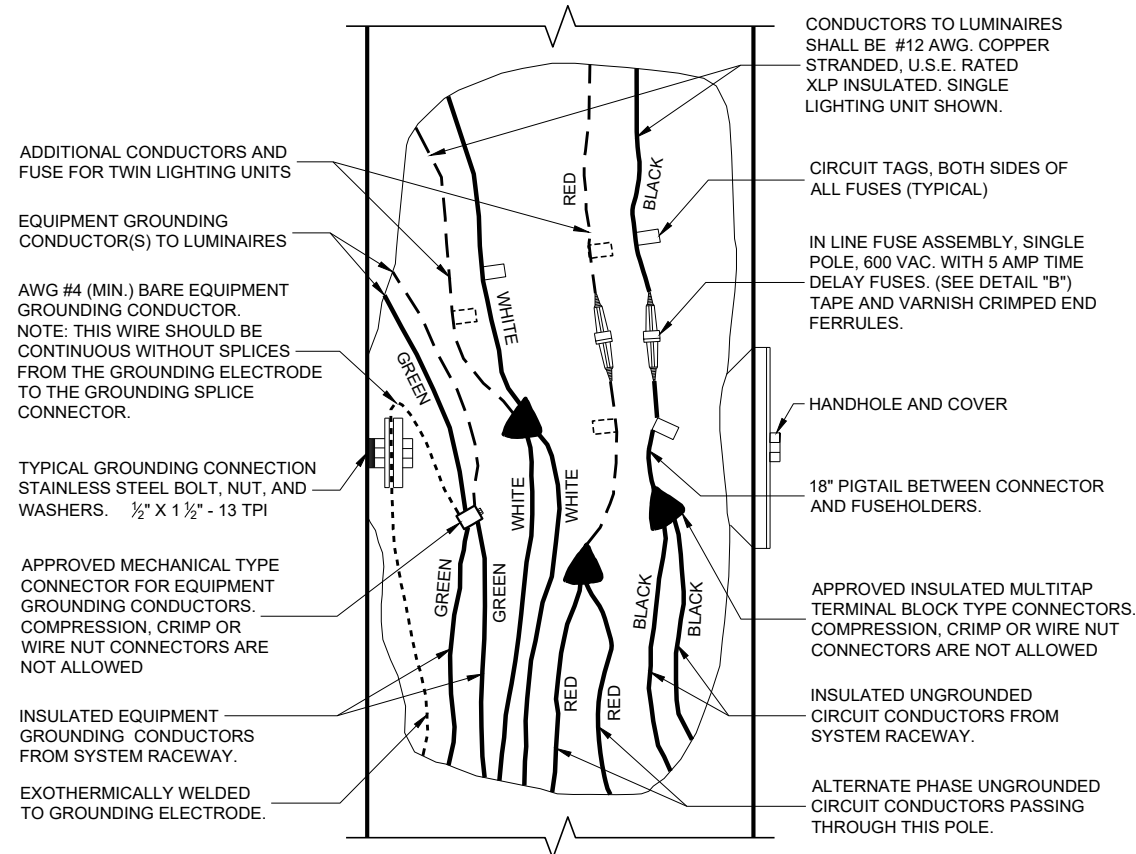

3 WIRE - 120, 240 OR 480 VAC (UNGROUNDING CONDUCTORS) WITH GROUNDING CONDUCTOR AND EQUIPMENT GROUNDING CONDUCTOR

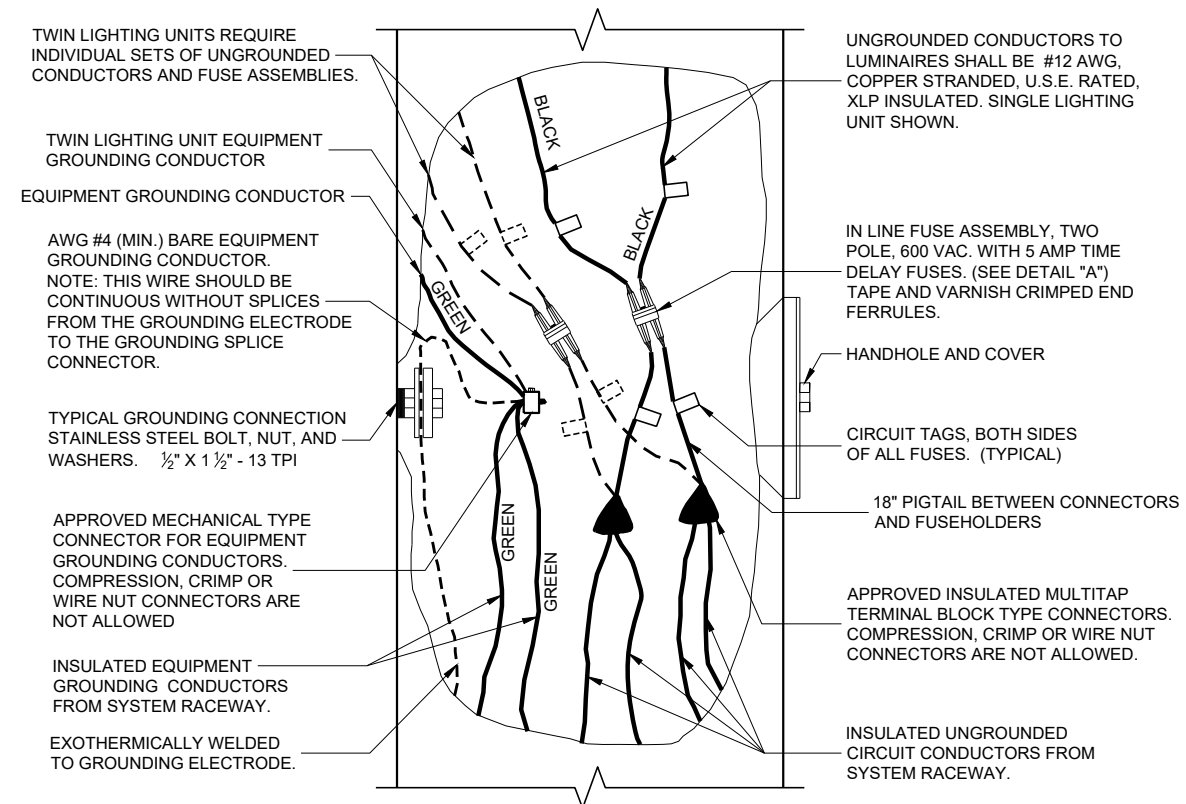

2 WIRE - 240 OR 480 VAC (UNGROUNDING CONDUCTORS) WITH EQUIPMENT GROUNDING CONDUCTOR

NON - FREEWAY LIGHTING UNIT POLE WIRING

STATE OF WISCONSIN
DEPARTMENT OF TRANSPORTATION

APPROVED
November 2018 /S/ Ahmet Demirelek
DATE STATE ELECTRICAL ENGINEER

FHWA

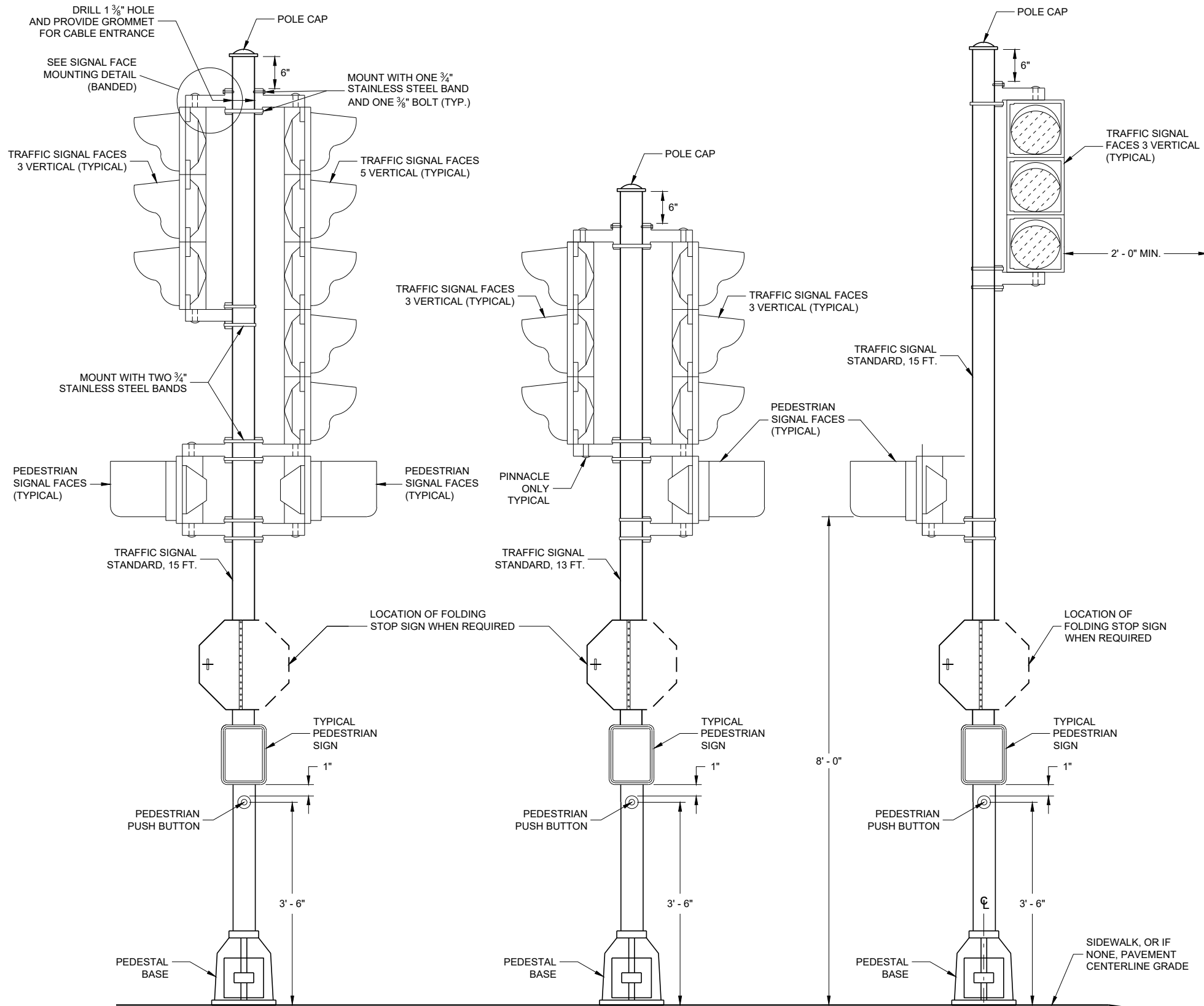

TRAFFIC SIGNAL STANDARD - 15 FT.

TRAFFIC SIGNAL STANDARD - 13 FT.

TRAFFIC SIGNAL STANDARD - 15 FT. 3M MOUNTING (TYPICAL)

GENERAL NOTES

DETAILS OF CONSTRUCTION, MATERIALS AND WORKMANSHIP NOT SHOWN ON THIS DRAWING SHALL CONFORM TO THE PERTINENT REQUIREMENTS OF THE CONTRACT.

SEE THE SIGNAL PLAN FOR REQUIRED SIGNAL FACE SIZES.

ALL PEDESTAL BASES SHALL BE MOUNTED ON CONCRETE BASE - TYPE 1.

FOR APPROVED MOUNTING HARDWARE, SEE THE CONTRACT SPECIAL PROVISIONS.

POLYCARBONATE MOUNTING BRACKETS SHALL BE USED.

LENGTH AND LOCATION OF TRAFFIC SIGNAL STANDARDS SHALL BE AS SHOWN ON THE PLANS.

OPTICALLY PROGRAMMED SIGNAL FACES SHALL BE MASKED IN ACCORDANCE WITH MANUFACTURERS INSTRUCTIONS, AND UNDER THE DIRECTIONS OF THE REGION TRAFFIC ENGINEER.

FOLDING STOP SIGNS SHALL BE IN ACCORDANCE WITH THE MUTCD AND/OR THE LATEST WISCONSIN SUPPLEMENT. THE SIGNS SHALL BE SIZED AND LOCATED AS CALLED FOR IN THE PLANS.

PEDESTRIAN SIGNS SHALL BE AS DESIGNATED IN THE PLANS.

FURNISH AND INSTALL VENTILATED, CAST, METALLIC (ALUMINUM ALLOY) CAPS. FASTEN CAPS WITH ONE (1) 1/4" X 3/4" - 20 TPI STAINLESS STEEL, HEX HEAD BOLT.

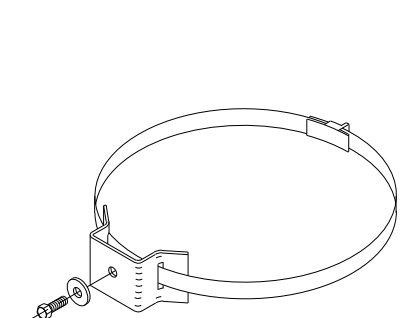

TYPICAL SIGN MOUNTING BAND (TOP AND BOTTOM OF SIGN)

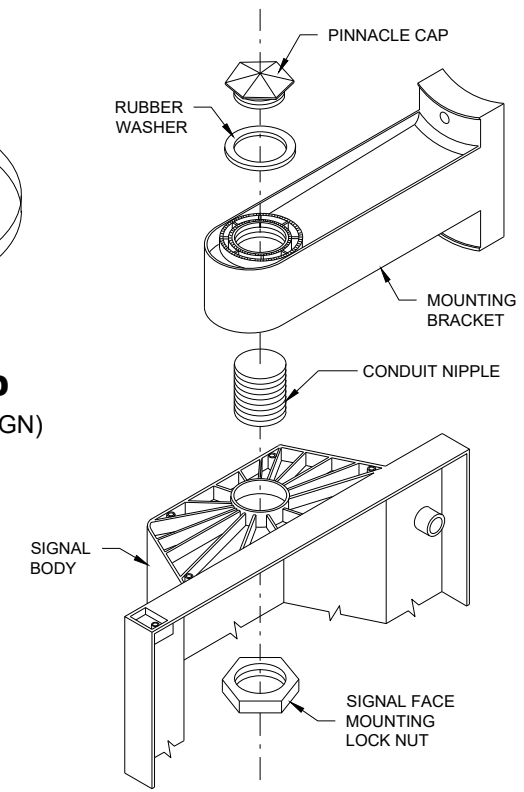

SIGNAL FACE MOUNTING DETAIL (BANDED)

TRAFFIC SIGNAL STANDARD POLY BRACKET MOUNTINGS (TYPICAL) 13 FT. OR 15 FT.

STATE OF WISCONSIN
DEPARTMENT OF TRANSPORTATION

APPROVED
2/28/2013 DATE /S/ Ahmet Demirelek
STATE ELECTRICAL ENGINEER

FHWA

6

6

SDD 09E06 - 05

SDD 09E06 - 05

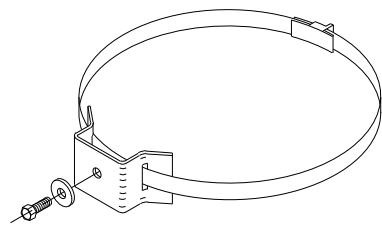

TYPICAL SIGN MOUNTING BAND
(TOP AND BOTTOM OF SIGN)

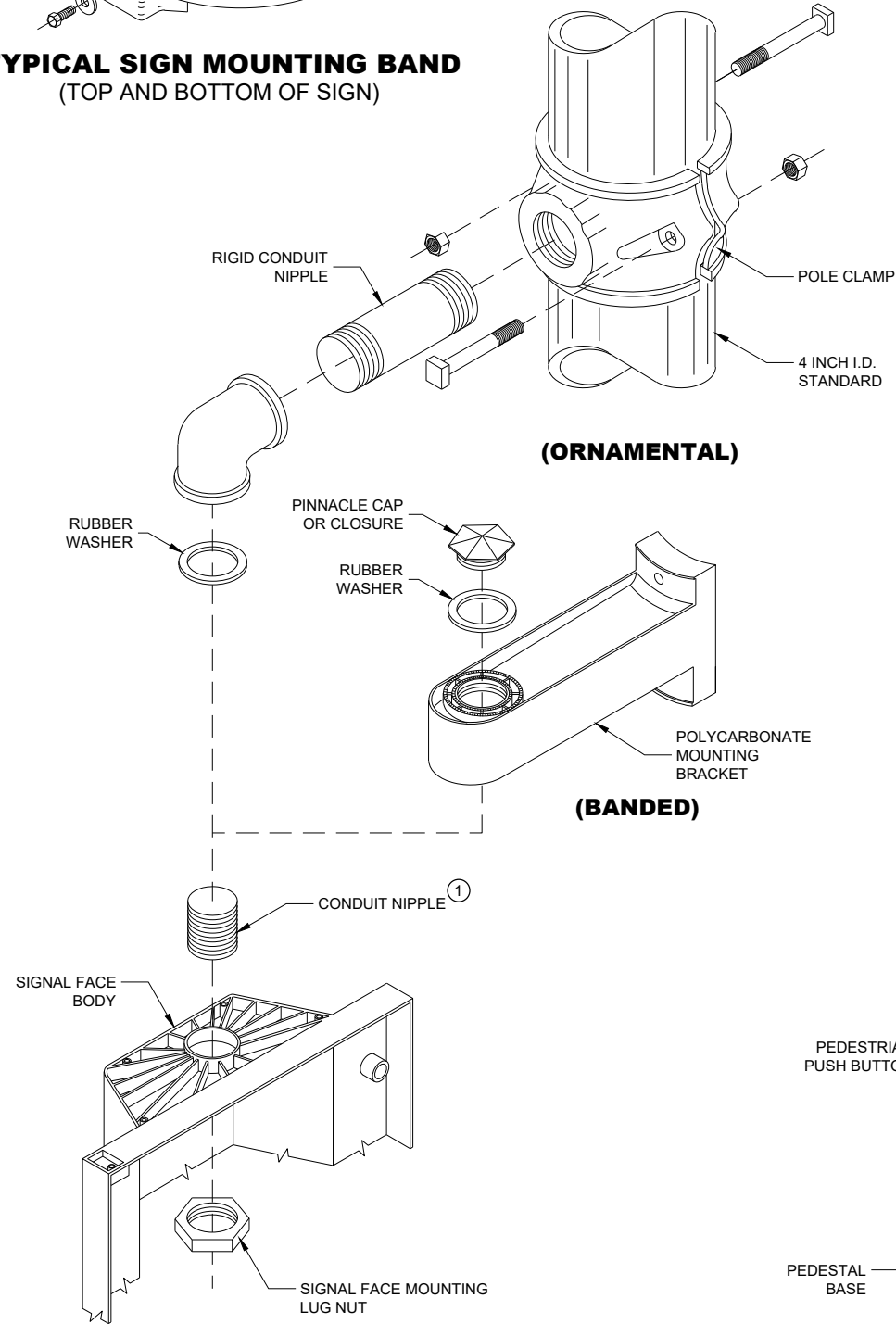

SIGNAL FACE MOUNTING DETAILS

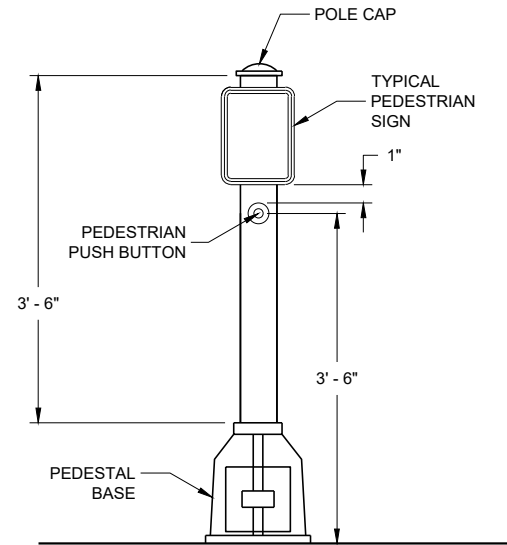

PEDESTRIAN PUSH BUTTON
TYPICAL MOUNTING

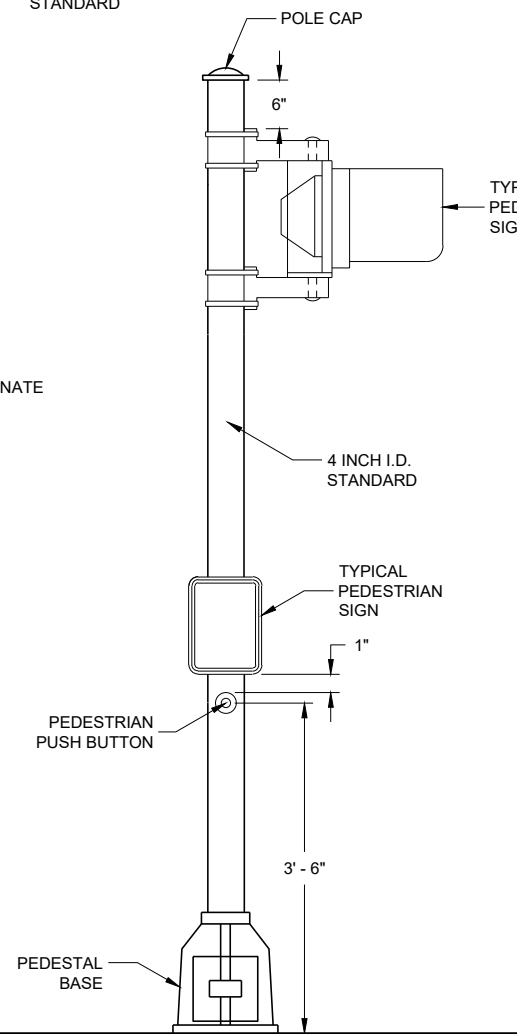

PEDESTRIAN FACE STANDARD - 10 FT.
(WALK - DON'T WALK)

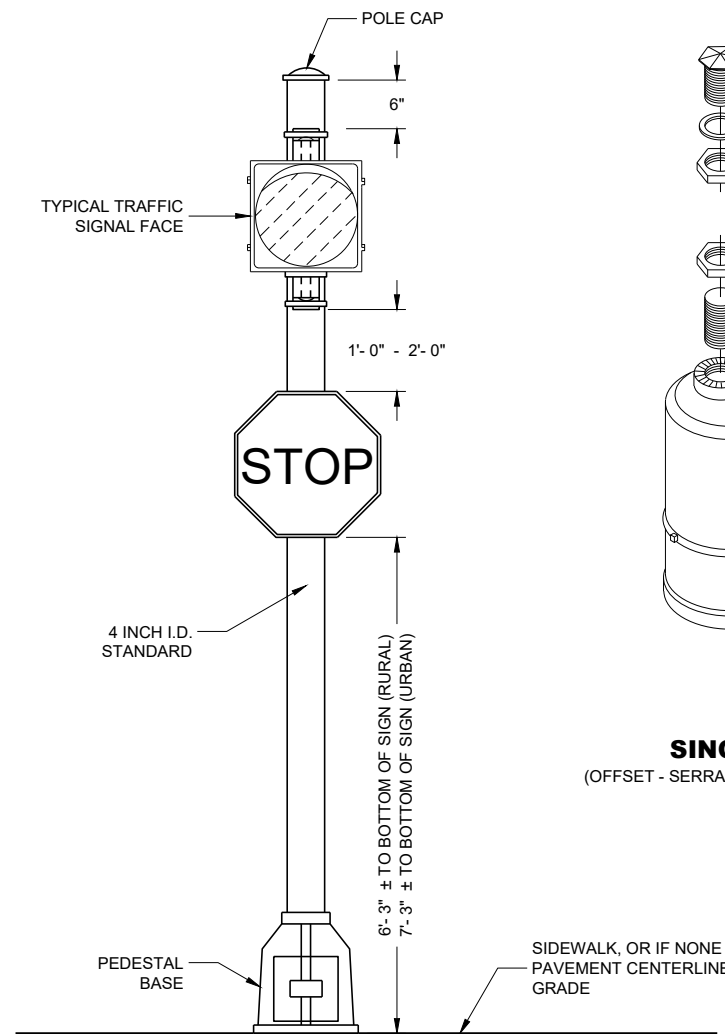

STANDARD FLASHER
10 FOOT, 13 FOOT OR 15 FOOT AS REQUIRED

GENERAL NOTES

DETAILS OF CONSTRUCTION, MATERIALS AND WORKMANSHIP NOT SHOWN ON THIS DRAWING SHALL CONFORM TO THE PERTINENT REQUIREMENTS OF THE CONTRACT.

SEE THE SIGNAL PLAN FOR REQUIRED SIGNAL FACE SIZES.

LOCATIONS SHALL BE AS SHOWN ON THE PLANS, UNLESS APPROVED BY THE ENGINEER IN THE FIELD.

ALL PEDESTAL BASES SHALL BE MOUNTED ON CONCRETE BASE - TYPE 1.

FOR APPROVED MOUNTING HARDWARE, SEE THE CONTRACT SPECIFICATIONS.

POLYCARBONATE SIGNAL FACE MOUNTING BRACKETS SHALL BE USED UNLESS ORNAMENTAL POLE CLAMPS ARE SPECIFIED.

LENGTH OF TRAFFIC STANDARDS SHALL BE AS SHOWN ON THE PLANS.

MOUNTINGS AND BRACKETS SHALL BE AS SHOWN ON THE PLANS OR DESCRIBED IN THE SPECIAL PROVISIONS (BY THE REGION TRAFFIC ENGINEER).

PEDESTRIAN SIGNS SHALL BE AS DESIGNATED IN THE PLANS.

FURNISH AND INSTALL VENTILATED, CAST, METALLIC (ALUMINUM ALLOY) CAPS. FASTEN CAPS WITH ONE (1) 1/2" X 3/4" - 20 TPI STAINLESS STEEL, HEX HEAD BOLT.

① USE 1 1/2" ID NIPPLES ZINC-COATED RIGID METAL CONDUIT, LONG ENOUGH TO ACCOMMODATE FULL DEPTH THREADING INTO THE HEAD MOUNTING LOCK NUT IN ORDER TO TIGHTEN THE FACE, BUT THAT DO NOT INTERFERE WITH REFLECTOR CLOSURE. THREAD THE NIPPLE INTO THE MOUNTING BRACKET/ELBOW UNTIL TIGHT. USE APPROVED PINNACLE TYPE HARDWARE FROM A DEPARTMENT APPROVED MANUFACTURER TO CLOSE THE UNUSED 1 1/2" OPENING IN SIGNAL FACES AND BRACKET ENDS.

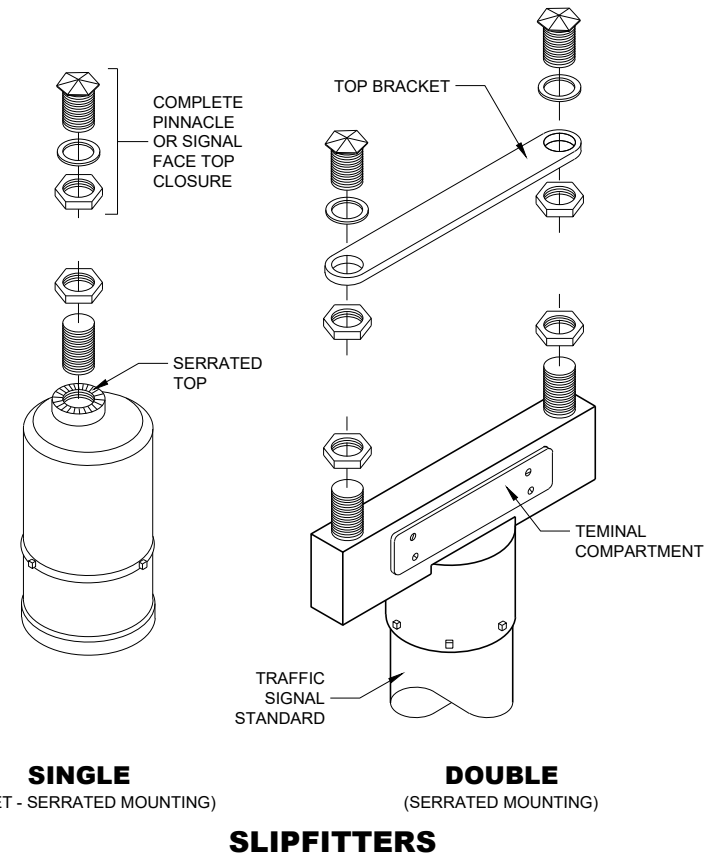

SINGLE
(OFFSET - SERRATED MOUNTING)

DOUBLE
(SERRATED MOUNTING)
SLIPFITERS

TRAFFIC SIGNAL STANDARD
PEDESTRIAN AND FLASHER
TYPICAL MOUNTING DETAILS

STATE OF WISCONSIN
DEPARTMENT OF TRANSPORTATION

APPROVED
November 2018 /S/ Ahmet Demirelek
DATE STATE ELECTRICAL ENGINEER
FHWA

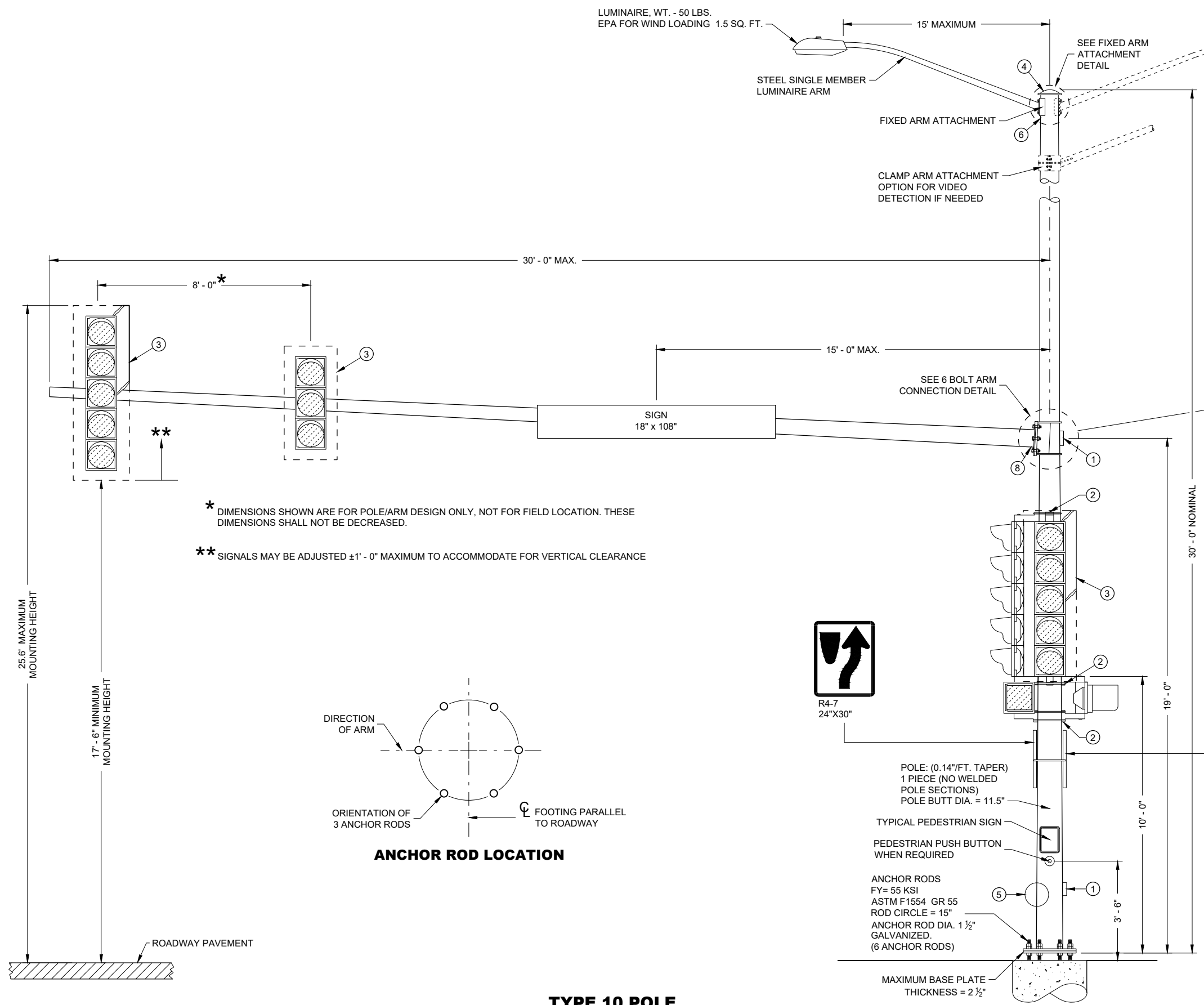

* DIMENSIONS SHOWN ARE FOR POLE/ARM DESIGN ONLY, NOT FOR FIELD LOCATION. THESE DIMENSIONS SHALL NOT BE DECREASED.

** SIGNALS MAY BE ADJUSTED ±1' - 0" MAXIMUM TO ACCOMMODATE FOR VERTICAL CLEARANCE

ANCHOR ROD LOCATION

**TYPE 10 POLE
15' - 30' MONOTUBE ARM
(MAXIMUM LOAD)**

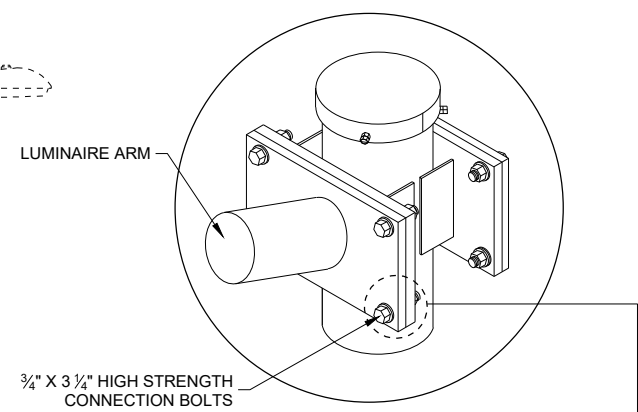

FIXED ARM ATTACHMENT DETAIL

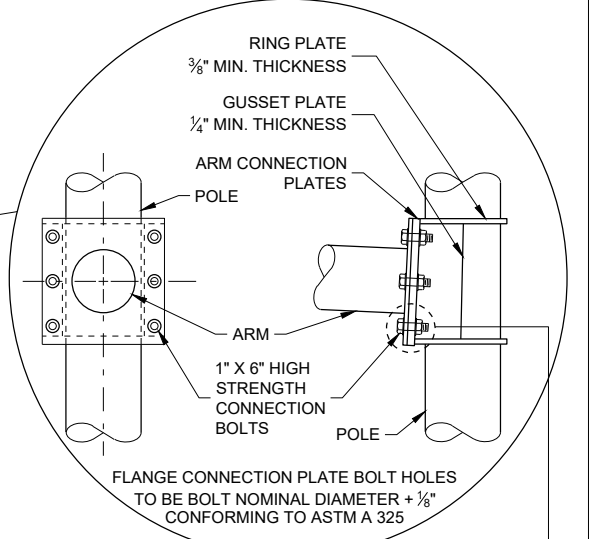

6 BOLT ARM CONNECTION DETAIL

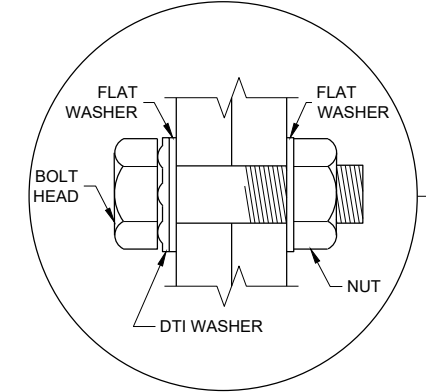

RECOMMENDED BOLT ASSEMBLY DETAIL

**TYPE 10 POLE
15' - 30' MONOTUBE ARM**

STATE OF WISCONSIN
DEPARTMENT OF TRANSPORTATION

APPROVED
August 2020 /S/ Ahmet Demirelek
DATE STATE ELECTRICAL ENGINEER

FHWA

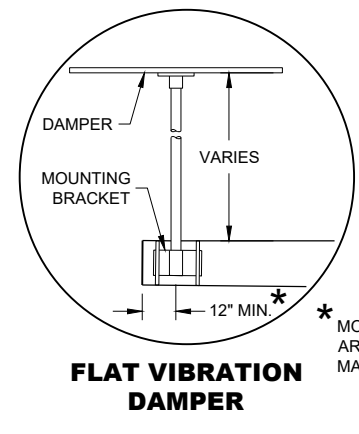
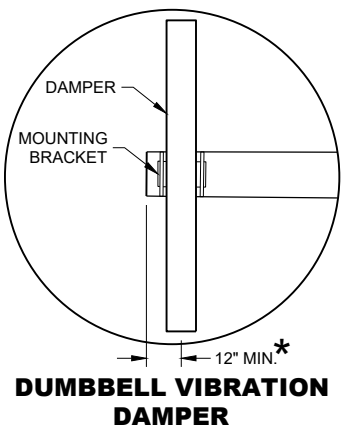

* MOUNT AS CLOSE TO END OF MAST ARM FOR MAXIMUM DAMPING PER MANUFACTURER'S RECOMMENDATIONS.

LUMINAIRE, WT. - 50 LBS.
EPA FOR WIND LOADING 1.5 SQ. FT.

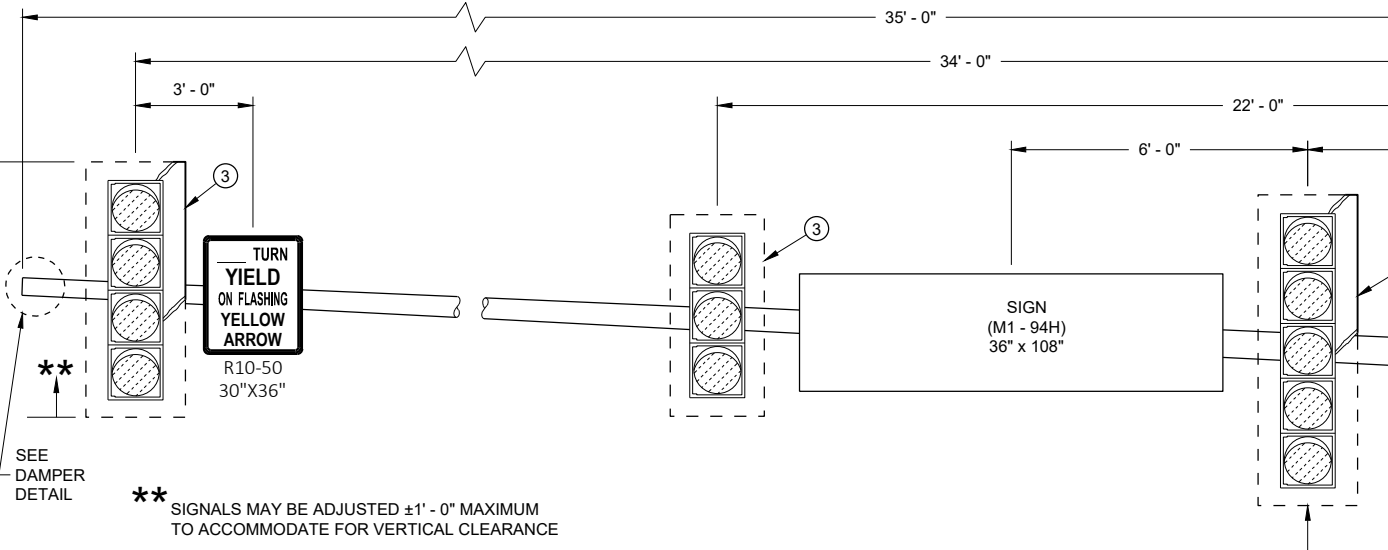
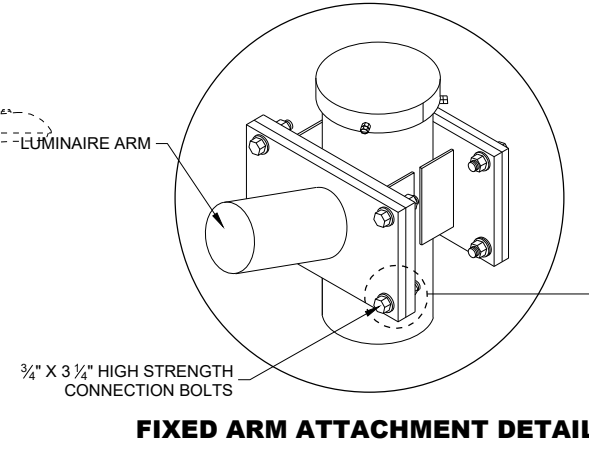
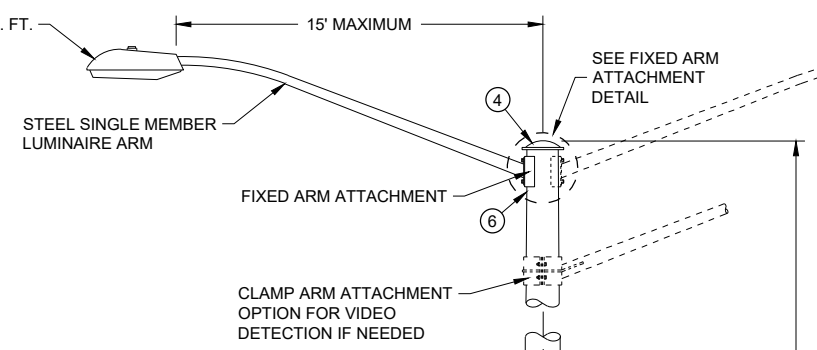

** SIGNALS MAY BE ADJUSTED ±1' - 0" MAXIMUM TO ACCOMMODATE FOR VERTICAL CLEARANCE

SEE 6 BOLT ARM CONNECTION DETAIL

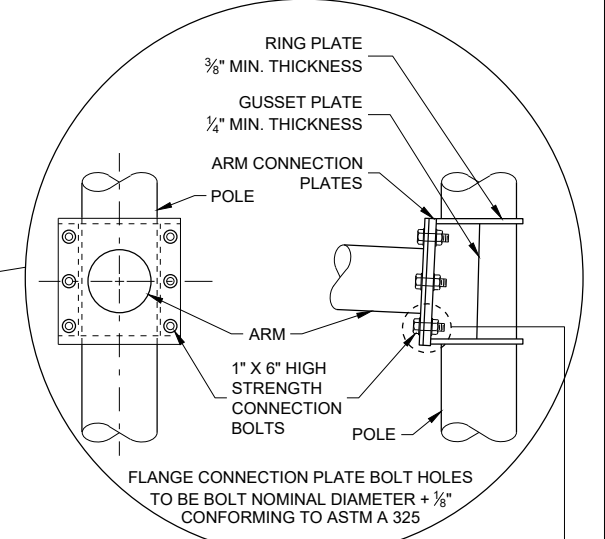

6 BOLT ARM CONNECTION DETAIL

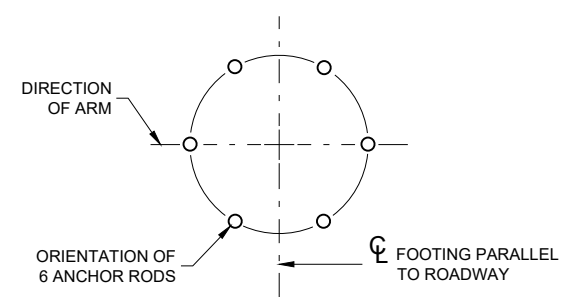

**TYPE 10 SPECIAL POLE
35' MONOTUBE ARM
(MAXIMUM LOAD)**

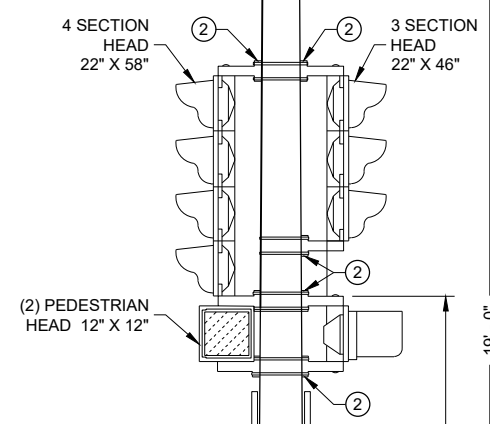

POLE: (0.14"/FT. TAPER), 1 PIECE (NO WELDED POLE SECTIONS)
POLE BUTT DIA. = 13"

TYPICAL PEDESTRIAN SIGN
PEDESTRIAN PUSH BUTTON WHEN REQUIRED

ANCHOR RODS
FY= 55 KSI
ASTM F1554 GR 55
ROD CIRCLE = 18"
ANCHOR ROD DIA. 1 1/2" GALVANIZED.
(MIN. 6 ANCHOR RODS)

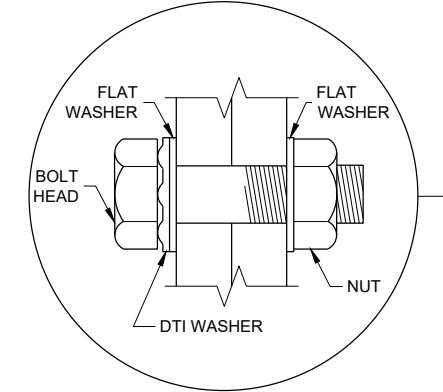
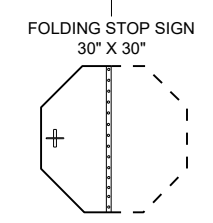

RECOMMENDED BOLT ASSEMBLY DETAIL

**TYPE 10 SPECIAL POLE
35' MONOTUBE ARM**

STATE OF WISCONSIN
DEPARTMENT OF TRANSPORTATION

APPROVED
August 2020 /S/ Ahmet Demirebilek
DATE STATE ELECTRICAL ENGINEER

FHWA

SDD 09E08 - 09f

SDD 09E08 - 09f

GENERAL NOTES

DETAILS OF CONSTRUCTION NOT SHOWN ON THIS DRAWING SHALL CONFORM TO THE PERTINENT REQUIREMENTS OF THE CONTRACT.

POLE TYPES 9 AND 10 ARE FOR ARM LENGTHS 15 FOOT TO 30 FOOT.

POLE TYPES 9 SPECIAL AND 10 SPECIAL ARE FOR ARM LENGTHS 35 FOOT, 40 FOOT, AND 45 FOOT.

POLE TYPES 12 AND 13 ARE FOR ARM LENGTHS 35 FOOT TO 55 FOOT.

MONOTUBE POLES AND ARMS SHALL BE GALVANIZED STEEL.

RING STIFFENED BUILT UP BOX TYPE OF ATTACHMENT FOR TRAFFIC SIGNAL ARM.

ONE PIECE POLE CONSTRUCTION (NO WELDED POLE SECTIONS).

STANDARD STRAIGHT ARM DESIGN (3% ± RISE).

SECTION 657, POLES OF THE STANDARD SPECIFICATION SHALL APPLY TO THIS DRAWING.

PROVIDE WIREWAY THRU POLE WALL AND ARM CONNECTION PLATES. PROVIDE ROUND, SMOOTH INSIDE SURFACE.

MANUFACTURER'S SUBMITTED POLE DESIGNS AND DRAWINGS SHALL BE SIGNED AND STAMPED BY A REGISTERED PROFESSIONAL ENGINEER AND CERTIFIED AS BEING IN COMPLIANCE WITH THE AASHTO "LRFD SPECIFICATIONS FOR STRUCTURAL SUPPORTS FOR HIGHWAY SIGNS, LUMINAIRES AND TRAFFIC SIGNAL 2015 1ST EDITION (INCLUDING INTERIM REVISIONS)" AND ALL PERTINENT WISDOT SPECIFICATIONS AND DRAWINGS FOR THE LIGHTING STRUCTURES AS FOLLOWS:

CATEGORY III FATIGUE LOADS OF GALLOPING, TRUCK GUSTS (AT 45 MPH VEHICLE VELOCITY) AND NATURAL WIND GUSTS FOR DESIGN OF TYPE 9 AND TYPE 10 STRUCTURES.

CATEGORY II FATIGUE LOADS OF TRUCK GUSTS (AT 45 MPH VEHICLE VELOCITY) AND NATURAL WIND GUSTS FOR DESIGN OF TYPE 9 SPECIAL AND TYPE 10 SPECIAL STRUCTURES. IN LIEU OF DESIGNING FOR GALLOPING, A VIBRATION DAMPER MITIGATION DEVICE IS REQUIRED TO BE SUPPLIED AND INSTALLED AT THE END OF THE MAST ARM.

CATEGORY II FATIGUE LOADS OF GALLOPING, TRUCK GUSTS (AT 45 MPH VEHICLE VELOCITY) AND NATURAL WIND GUSTS FOR DESIGN OF TYPE 12 AND TYPE 13 STRUCTURES.

115 MPH (700 YEAR MRI BASIC WIND SPEED).

SECURE THE OPENING BELOW THE BASE PLATE WITH STAINLESS STEEL OR GALVANIZED STEEL MESH AND SECURE THE MESH WITH 3/4" STAINLESS STEEL BANDING AROUND THE LEVELING NUTS.

INDENT PRINT (NOMINAL 1/2" HIGH) THE POLE LENGTH AND FIRST TWO LETTERS OF THE MANUFACTURERS NAME ON TWO SIDES OF THE BASE PLATE 180 DEGREES APART, BEFORE GALVANIZING. THE ARM SHALL BE IDENTIFIED WITH THE SAME INFORMATION BY INDENT PRINT.

SIGNAL FACE SHALL BE MOUNTED 6 INCHES (NOMINAL) FROM THE END OF THE MONOTUBE ARM OR AS SHOWN ON THE PLAN CONSTRUCTION DETAIL OR AS DIRECTED BY THE PROJECT ENGINEER/ELECTRICAL OPERATIONS PERSONNEL. MOUNT ALL LIKE HEAD AT SAME ELEVATION.

SIGN MOUNTING BRACKETS SHALL BE FURNISHED IN ACCORDANCE WITH SECTION 637 OF THE STANDARD SPECIFICATIONS FOR HIGHWAY AND STRUCTURE CONSTRUCTION.

- ① DESIGN FOR MAXIMUM ALLOWABLE HAND HOLE WITH COVER ASSEMBLY WITH TWO 1/4" X 3/4" - 20 TPI STAINLESS STEEL HEX HEAD BOLTS.
- ② SIGNAL MOUNTING BRACKETS FOR POLE MOUNTING, MOUNT WITH CAP SCREW AND BANDING (SEE SPECIFICATION SECTION 658).
- ③ SECURELY MOUNT BACK PLATES, PROJECTING 5" BEYOND ALL SIDES OF THE SIGNAL FACE HOUSING, PER MANUFACTURERS RECOMMENDATIONS.
- ④ THE TOP OF THE POLE SHAFT AND THE MONOTUBE ARM SHALL BE EQUIPPED WITH A REMOVABLE, VENTILATED CAP HELD SECURELY IN PLACE WITH SET SCREWS.
- ⑤ FACTORY WELDED BRACKET FOR GROUNDING LUG, OPPOSITE HAND HOLD, (LUG AND HARDWARE PAID UNDER SEPARATE ITEM). PROVIDE HOLE IN BRACKET FOR 1/4" X 3/4" - 20 TPI STAINLESS STEEL HEX HEAD BOLT.
- ⑥ FACTORY WELDED "J" HOOK FOR STRAIN RELIEF FOR POLE LUMINAIRE WIRE.
- ⑦ INSTALL STRUCTURAL IDENTIFICATION PLAQUES.

STRUCTURAL IDENTIFICATION PLAQUES SHALL BE PLACED ON THE POLES IN THE SAME DIRECTION AS THE ARM.

MOUNTING HEIGHT SHALL BE 6' - 0" ABOVE THE CURB OR SHOULDER. ADJUST IF IT IS KNOWN THAT REQUIRED TRAFFIC SIGNS WILL BE OBSTRUCTED.

- ⑧ FACTORY DRILLED 1/2" DRAIN HOLE 2" FROM FLANGE CONNECTION PLATE.

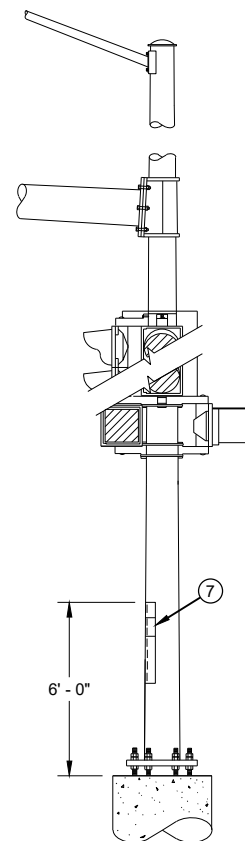

**STRUCTURAL IDENTIFICATION
PLAQUE PLACEMENT**

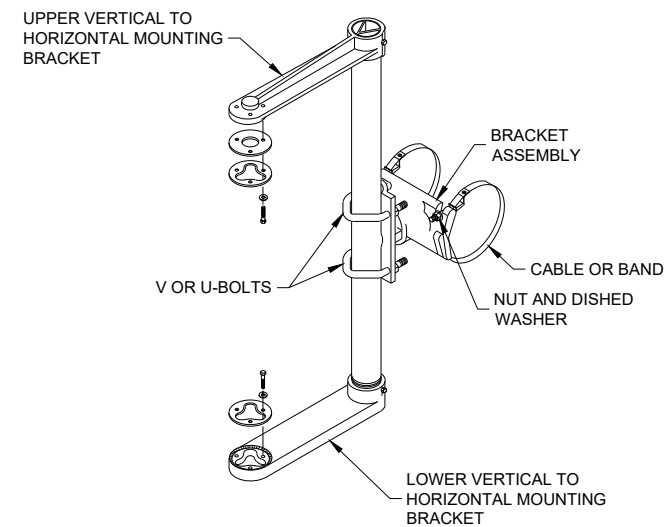

**SIGNAL FACE MOUNTING BRACKET
DETAIL FOR MONOTUBE ARM**
(MOUNT PER MANUFACTURER'S RECOMMENDATION)

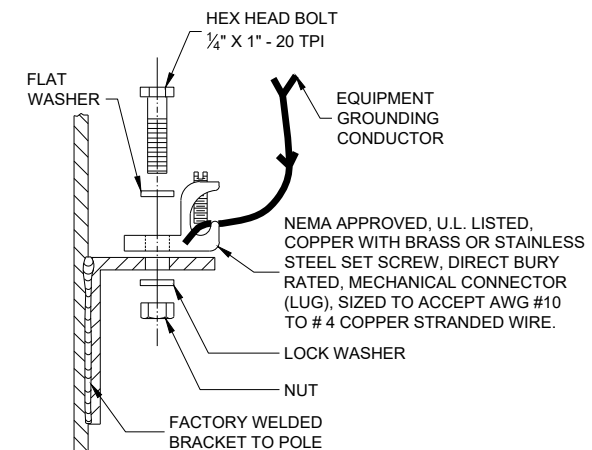

**TYPICAL GROUNDING
CONNECTIONS**

NUT, BOLT AND WASHERS SHALL BE STAINLESS STEEL

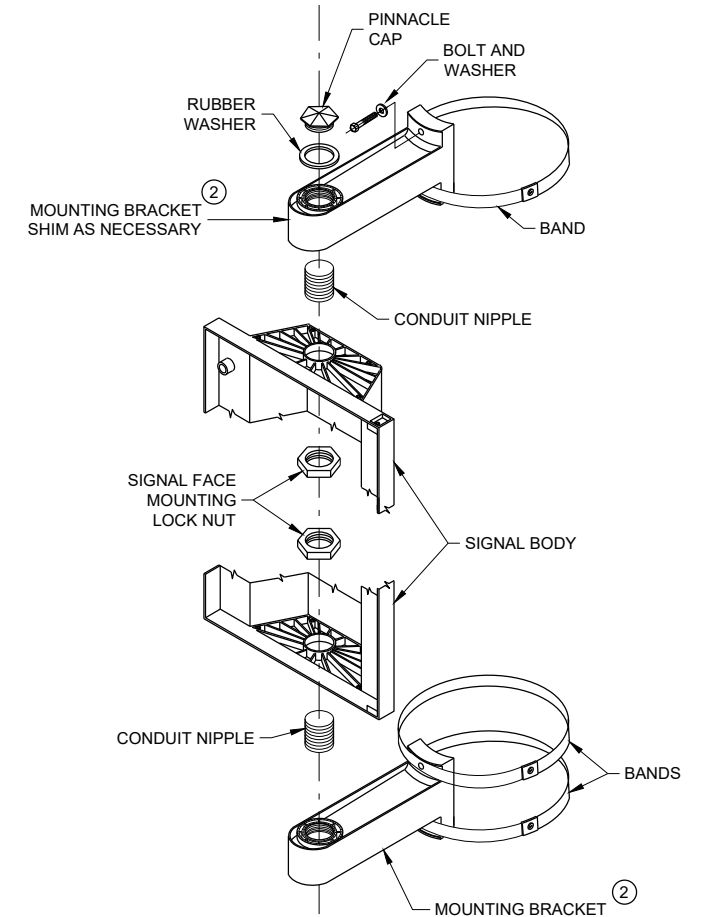

**SIGNAL FACE VERTICAL
MOUNTING DETAIL**

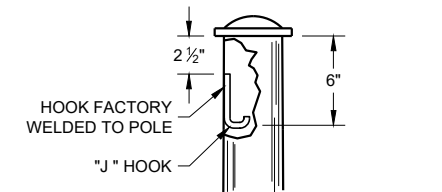

**TYPICAL "J" HOOK
WIRE SUPPORT**

**GENERAL NOTES AND
HARDWARE FOR TYPES 9,10,
9/10 SPECIAL, 12 AND 13
POLES WITH MONOTUBE ARMS**

STATE OF WISCONSIN
DEPARTMENT OF TRANSPORTATION

APPROVED
August 2020 /S/ Ahmet Demirbilek
DATE STATE ELECTRICAL
ENGINEER

FHWA

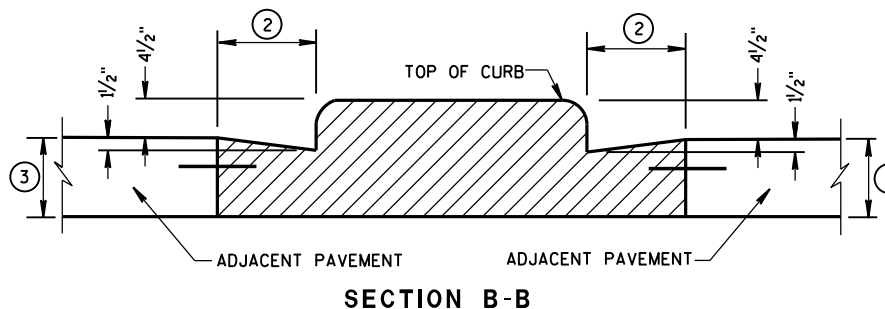
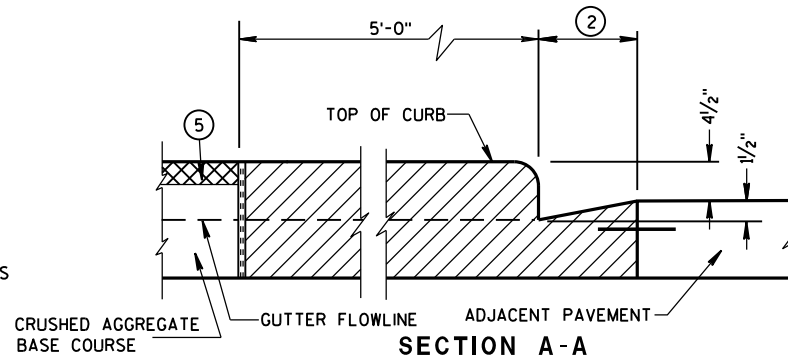
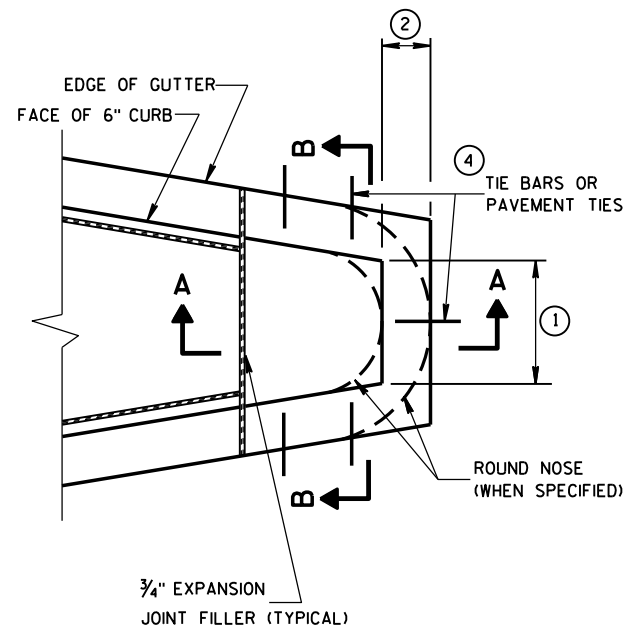
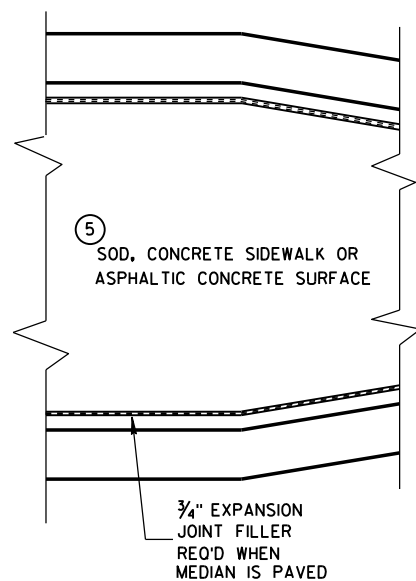

CONCRETE MEDIAN BLUNT NOSE DETAIL

GENERAL NOTES

DETAILS OF CONSTRUCTION, MATERIALS AND WORKMANSHIP NOT SHOWN ON THIS DRAWING SHALL CONFORM TO THE PERTINENT REQUIREMENTS OF THE STANDARD SPECIFICATIONS AND THE APPLICABLE SPECIAL PROVISIONS.

- ① SEE PLAN FOR MEDIAN NOSE WIDTH AND RADIUS (FOR ROUND NOSE ALTERNATE).
- ② WIDTH OF GUTTER TO MATCH EXISTING ADJACENT GUTTER OR AS SPECIFIED ELSEWHERE IN THE PLAN.
- ③ DEPTH EQUAL TO ADJACENT PAVEMENT. ADJACENT PAVEMENT STRUCTURE DETAILS ARE SHOWN ON THE PLAN. TYPICAL OPTIONS ARE:
 - (1) NEW OR EXISTING CONCRETE PAVEMENT.
 - (2) ASPHALTIC CONCRETE PAVEMENT OVER NEW OR EXISTING CONCRETE BASE COURSE.
 - (3) ASPHALTIC CONCRETE PAVEMENT OVER CRUSHED AGGREGATE BASE COURSE.
- ④ TIE BARS OR PAVEMENT TIES REQUIRED IN NEW CONCRETE PAVEMENT OR CONCRETE BASE COURSE. TIE BARS SHALL BE NO. 4 X 2'-0" SPACED AT 2'-0" C-C.
- PAVEMENT TIES REQUIRED IN EXISTING CONCRETE BASE COURSE. PAVEMENT TIES SHALL BE NO. 6 X 1'-0" SPACED AT 3'-0" C-C INSTALLED ON A HORIZONTAL SKEW OF 6:1. THE DIRECTION OF SKEW SHALL ALTERNATE AFTER EVERY ONE OR TWO BARS.
- ⑤ SURFACE TYPE AND DETAILS ARE SHOWN ELSEWHERE IN THE PLAN.

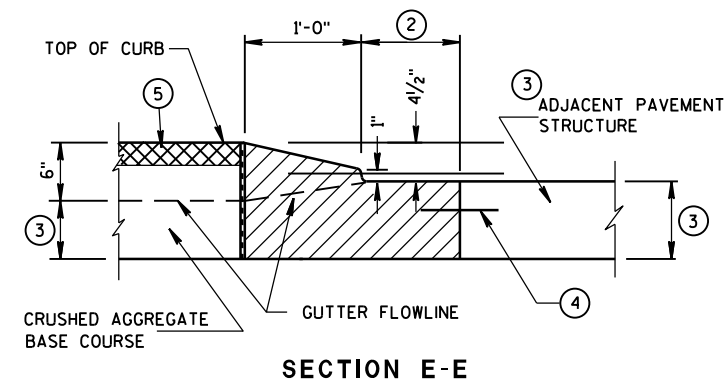
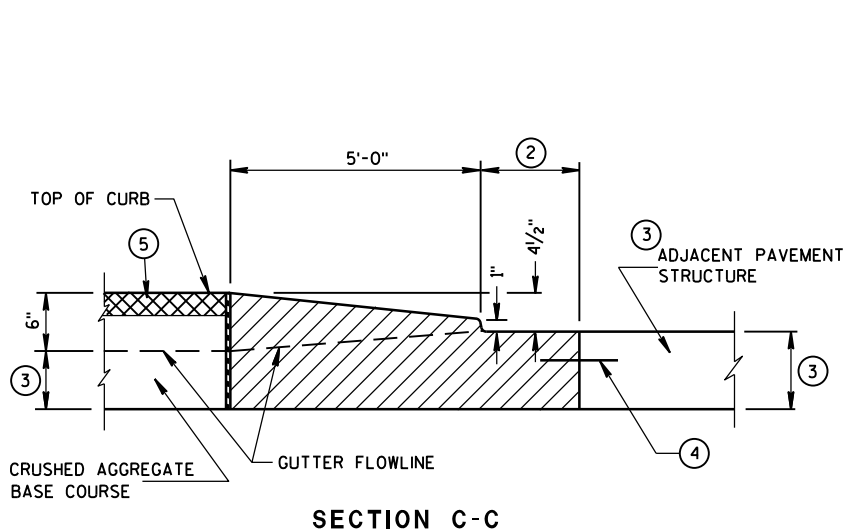
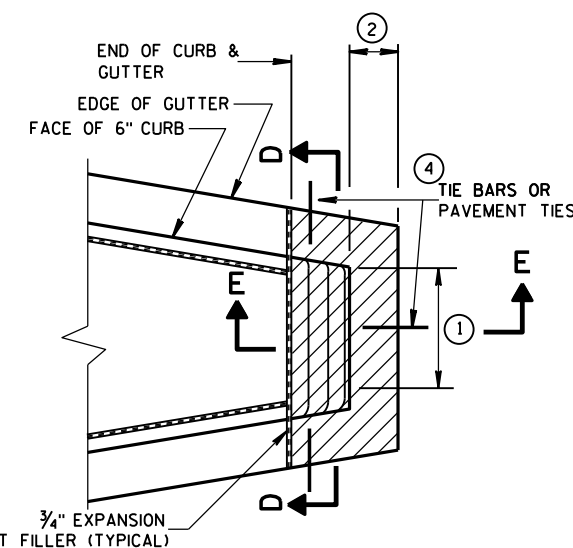

CONCRETE MEDIAN SLOPED NOSE TYPE 2

CONCRETE MEDIAN SLOPED NOSE TYPE 1

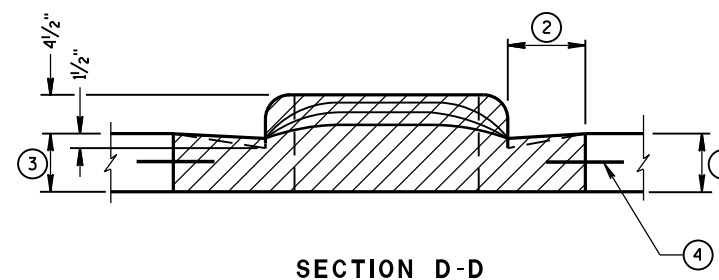

SECTION D-D

CONCRETE MEDIAN NOSE

STATE OF WISCONSIN
DEPARTMENT OF TRANSPORTATION

APPROVED
6/8/2006 /s/ Jerry H. Zogg
DATE ROADWAY STANDARDS DEVELOPMENT
ENGINEER
FHWA

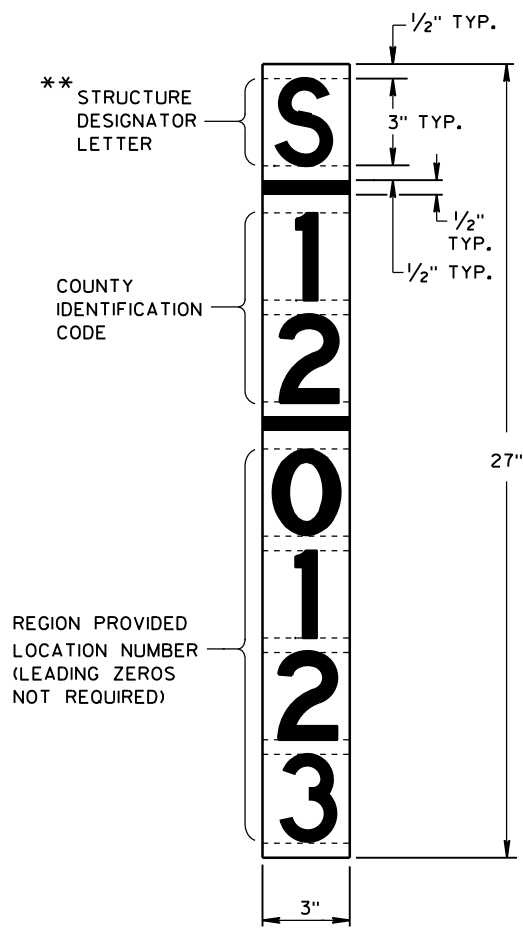
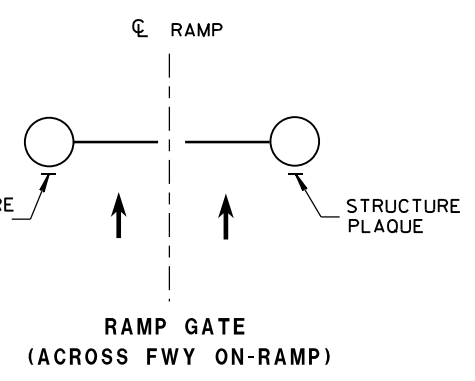
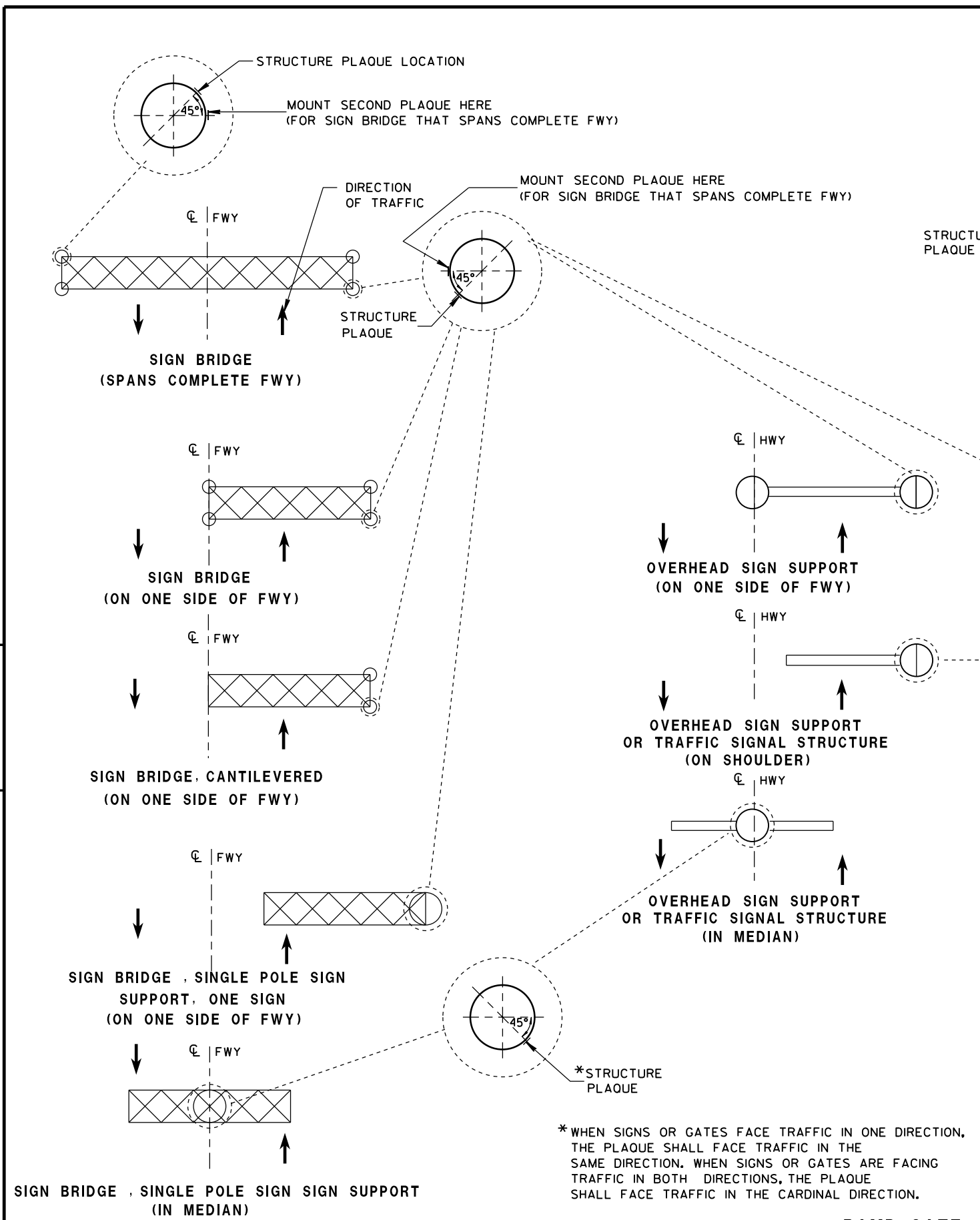

GENERAL NOTES

DETAILS OF CONSTRUCTION AND WORKMANSHIP NOT SHOWN IN THIS DRAWING SHALL CONFORM TO THE PERTINENT REQUIREMENTS OF THE CONTRACT.

PLAQUES SHALL BE INCIDENTAL TO ALL NEW INSTALLATIONS.

IF THE PROPOSED SIGN BRIDGE OR OVERHEAD SIGN SUPPORT IS REPLACING AN EXISTING SIGN BRIDGE OR OVERHEAD SIGN SUPPORT, A NEW IDENTIFICATION PLAQUE WILL BE REQUIRED.

FASTEN TOP, CENTER AND BOTTOM OF PLAQUE TO POLE OR OTHER LOCATION AS FOLLOWS:

- GALVANIZED STEEL SHAFT - 3 STAINLESS STEEL POP RIVETS
- A588 STEEL SHAFT - SHIM FOR DRAINAGE WITH STAINLESS WASHERS; FASTEN WITH STAINLESS SELF-TAPPING SCREWS
- ALUMINUM SHAFTS - 3 ALUMINUM POP RIVETS

MOUNTING HEIGHT SHALL BE APPROXIMATELY 5.0' ABOVE CURB OR SHOULDER. ADJUST IF IT IS KNOWN THAT REQUIRED TRAFFIC SIGNS WILL OBSTRUCT.

PLAQUE MATERIALS:

- BASE - SHEET ALUMINUM, 0.060" THICK.
- FACE - WHITE, SELF-ADHESIVE VINYL SHEETING, NON-RETROREFLECTIVE
- LINES - BLACK, 1/2" WIDE, SELF-ADHESIVE
- CHARACTERS:- BLACK, SELF ADHESIVE, SERIES "D", SIZE AS SHOWN.

FOR SIGN BRIDGES, STRUCTURE MOUNTED, THE STRUCTURE PLAQUE SHALL BE MOUNTED HORIZONTALLY AS SHOWN ON THE DRAWING. THE STRUCTURE PLAQUE SHALL BE MOUNTED HORIZONTALLY TO THE BACK OF THE SIGN, BETWEEN THE ALUMINUM EXTRUSIONS, NEAR THE TOP LEFT HAND CORNER OF THE SIGN. THE BASE MATERIAL SHALL BE OMITTED AND THE FACE ADHERED DIRECTLY TO THE ALUMINUM SURFACE. PRIOR TO ADHERING THE MATERIAL, THE ALUMINUM SURFACE SHALL BE SMOOTH, CLEAN AND DRY.

WHERE SIGN BRIDGE ILLUMINATION IS PROVIDED, THE STRUCTURE MUST ALSO HAVE A SIGN BRIDGE CIRCUIT PLAQUE AS SHOWN IN THE ELECTRICAL DETAILS.

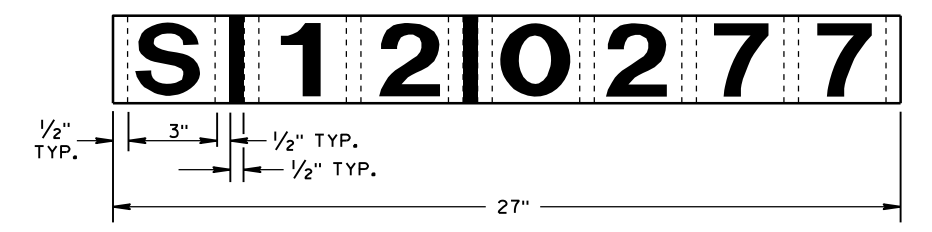

IDENTIFICATION PLAQUE FOR SIGN BRIDGE, STRUCTURE MOUNTED

** LETTER "G" UTILIZED FOR RAMP GATES. LETTER "S" UTILIZED FOR SIGN BRIDGES, OVERHEAD SIGN SUPPORTS, AND TRAFFIC SIGNALS.

LOCATION OF RAMP GATE, SIGN BRIDGE, OVERHEAD SIGN SUPPORT & TRAFFIC SIGNAL STRUCTURE PLAQUES

RAMP GATE, SIGN BRIDGE, OVERHEAD SIGN SUPPORT AND TRAFFIC SIGNAL STRUCTURE PLAQUE FOR SIGN BRIDGES AND OVERHEAD SIGN SUPPORT WHICH ARE NOT STRUCTURE MOUNTED

STRUCTURE IDENTIFICATION PLAQUES, RAMP GATES, SIGN BRIDGES, OVERHEAD SIGN SUPPORTS, & TRAFFIC SIGNALS	
STATE OF WISCONSIN DEPARTMENT OF TRANSPORTATION	
APPROVED 12/4/2012 DATE	/s/ Travis Feltes STATE TRAFFIC ENGINEER OF DESIGN
FHWA	

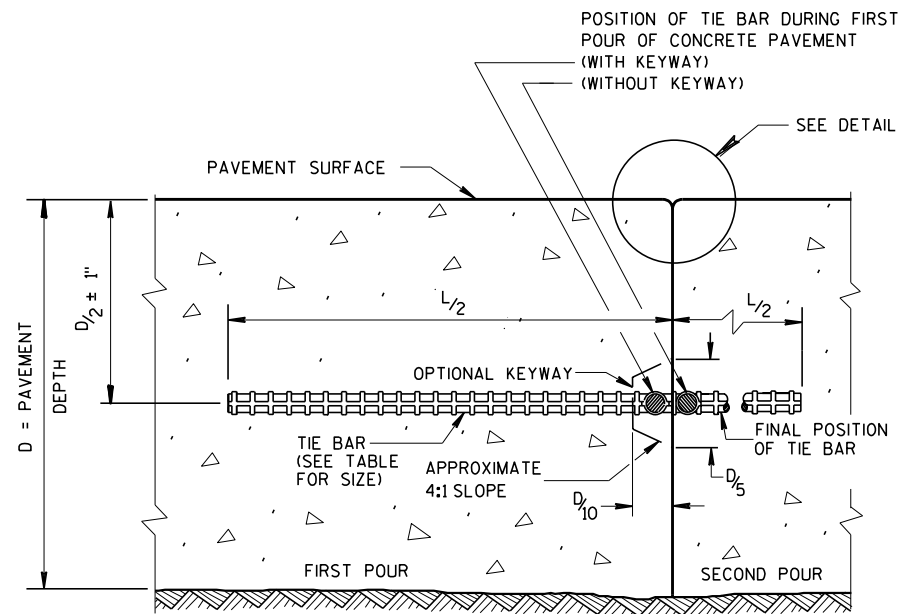

CONSTRUCTION JOINT

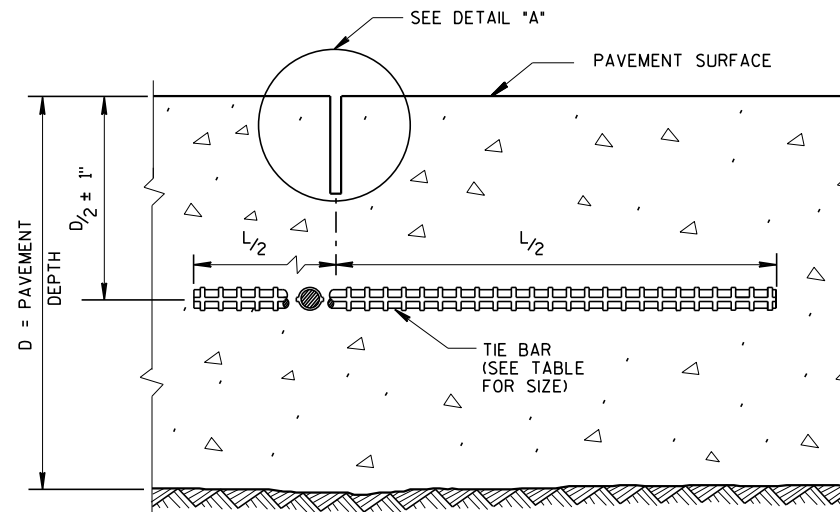

SAWED JOINT

GENERAL NOTES

CREATE A LONGITUDINAL JOINT FOR PAVEMENT WIDTHS GREATER THAN 15 FEET.

CORRELATE LONGITUDINAL JOINTS WITH LANE LINES WHEN POSSIBLE.

- ① ANCHOR TIE BARS INTO DRILLED HOLES WITH AN EPOXY.
- ② PAVEMENT THAT WAS IN PLACE PRIOR TO THE CONTRACT.

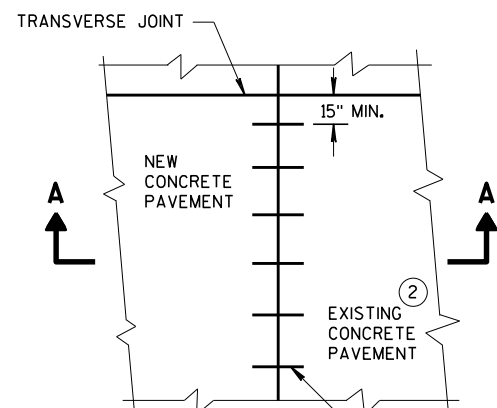

PLAN VIEW

NO. 6 TIE BARS SPACED 30" C-C, INSTALLED PERPENDICULAR TO THE LONGITUDINAL JOINT. ①

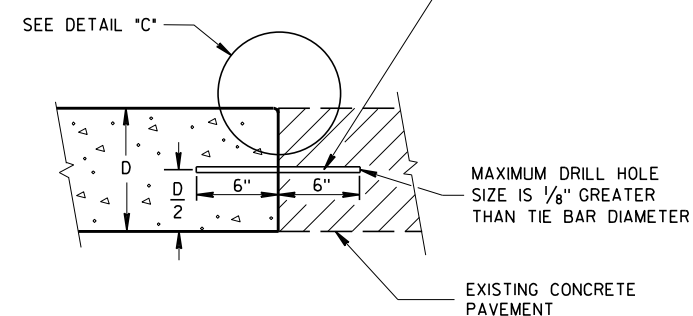

**SECTION A-A
LONGITUDINAL CONSTRUCTION JOINT
TIE BARS ANCHORED
INTO EXISTING PAVEMENT**

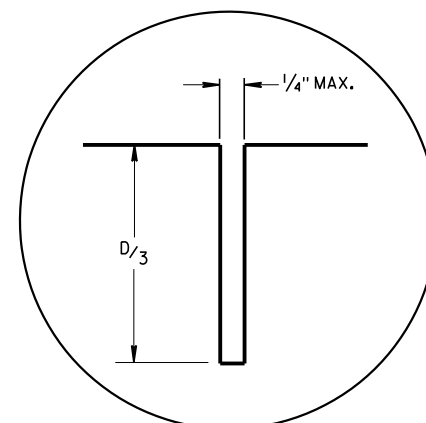

DETAIL "A"

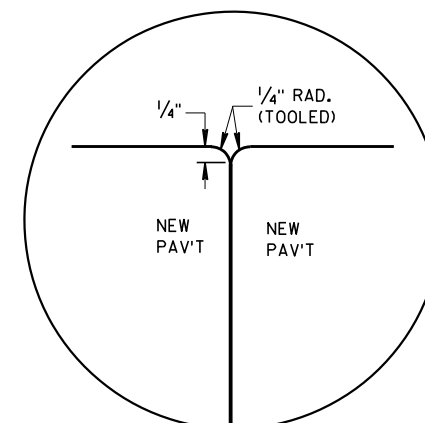

DETAIL "B"

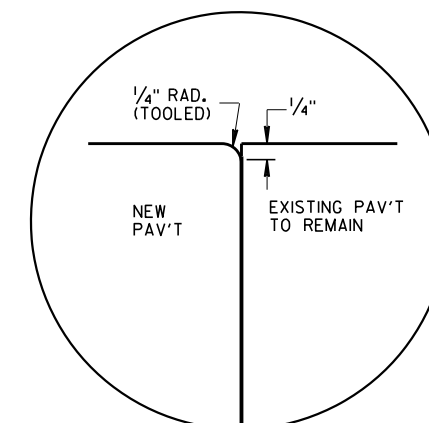

DETAIL "C"

TIE BAR TABLE

PAVEMENT DEPTH (D)	TIE BAR SIZE	TIE BAR LENGTH (L)	MAX. TIE BAR SPACING
< 10 1/2"	NO. 4	30"	36"
≥ 10 1/2"	NO. 5	36"	36"
	NO. 4 *	30"	24" **

* SUBSTITUTE BENT BARS AT LONGITUDINAL JOINTS WHEN EQUIPMENT LIMITATIONS DURING CONSTRUCTION WARRANT (e.g. AUXILIARY LANES OR TURN LANES)

** CONFORM TO 15" MINIMUM SPACING FROM TRANSVERSE JOINTS; SPACING BETWEEN TIE BARS WILL BE 30" AT TRANSVERSE JOINTS.

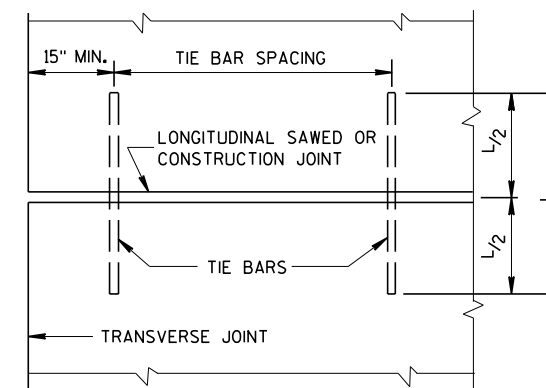

**PLAN VIEW
SHOWING LOCATION OF TIE BARS**

**CONCRETE PAVEMENT
LONGITUDINAL JOINTS AND TIES**

STATE OF WISCONSIN
DEPARTMENT OF TRANSPORTATION

APPROVED
March 2018 /S/ Peter Kemp, P.E.
DATE PAVEMENT SUPERVISOR
FHWA

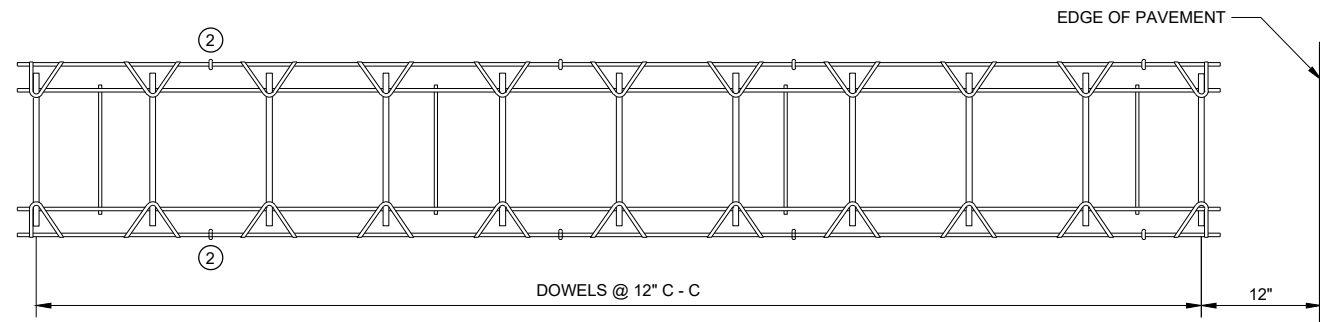

PLAN VIEW

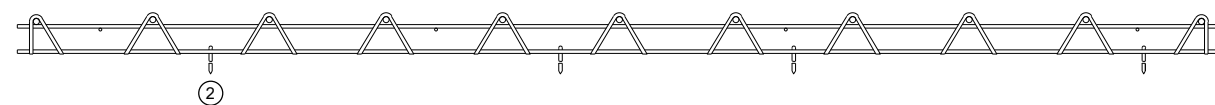

SIDE VIEW

CONTRACTION JOINT DOWEL ASSEMBLY ①

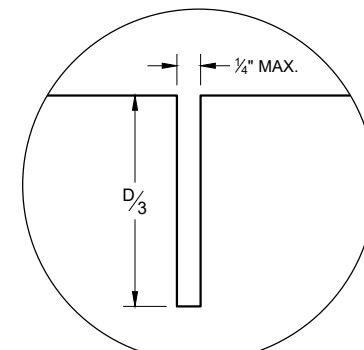

JOINT DETAIL

GENERAL NOTES

CONTRACTION JOINTS

CONSTRUCT TRANSVERSE CONTRACTION JOINTS NORMAL TO THE CENTERLINE. SHOW THE LOCATION OF CONTRACTION JOINTS THROUGH INTERSECTIONS ON THE PLANS OR AS DIRECTED BY THE ENGINEER.

INSTALL DOWEL BARS PARALLEL TO THE PAVEMENT CENTERLINE AND PAVEMENT SURFACE.

FOR PAVEMENT SLABS OF VARYING WIDTHS, LOCATE THE OUTER MOST DOWEL BAR SO THAT THE CENTER OF THE BAR IS A MINIMUM OF 6 INCHES FROM AND A MAXIMUM OF 18 INCHES FROM THE FREE EDGE OF PAVEMENT.

CONSTRUCTION JOINTS

LOCATE CONSTRUCTION JOINTS A MINIMUM OF 6 FEET FROM THE NEAREST CONTRACTION JOINT AND ALIGN PARALLEL TO THE CONTRACTION JOINTS.

- ① OBTAIN THE ENGINEER'S APPROVAL FOR THE USE OF ALTERNATIVE DESIGNS OF THE DOWEL ASSEMBLY. USE MECHANICAL DOWEL BAR INSERTERS OR DOWEL ASSEMBLIES WHEN CONSTRUCTION CONTRACTION JOINTS.
- ② SECURE BASKETS WITH ANCHORS TO HOLD DOWEL BARS IN THE CORRECT POSITION AND ALIGNMENT. TYPE, LOCATION, NUMBER AND LENGTH OF ANCHORS ARE DEPENDENT UPON FIELD CONDITIONS.
- ③ FORM OR SAW CONSTRUCTION JOINTS. PROVIDE A 1/4" RADIUS AT FORMED JOINTS.
- ④ PROVIDE A SMOOTH VERTICAL FACE FOR THE ENTIRE DEPTH OF THE PAVEMENT WHEN FORMING CONSTRUCTION JOINTS.
- ⑤ INSTALL DOWEL BARS AT CONSTRUCTION JOINTS BY FORMING OR DRILLING. INSTALL FORMED DOWEL BARS 12 INCHES C - C AND 12 INCHES FROM PAVEMENT EDGE. REMOVE EXCESS CONCRETE FROM THE FREE END OF THE DOWEL BAR IF DOWEL BARS ARE FORMED THROUGH A HEADER BOARD. INSTALL DRILLED DOWEL BARS ACCORDING TO THE "DRILLED DOWEL BAR CONSTRUCTION JOINT" DETAIL.
- ⑥ APPLY A THIN UNIFORM COATING OF SURFACE TREATMENT TO THE FREE END OF DOWEL BARS TO PREVENT BONDING.
- ⑦ ANCHOR DOWEL BARS AND TIE BARS INTO DRILLED HOLES WITH AN EPOXY. MAXIMUM DRILLED HOLE SIZE IS 1/8" GREATER THAN DOWEL BAR DIAMETER, 9 INCHES IN LENGTH.

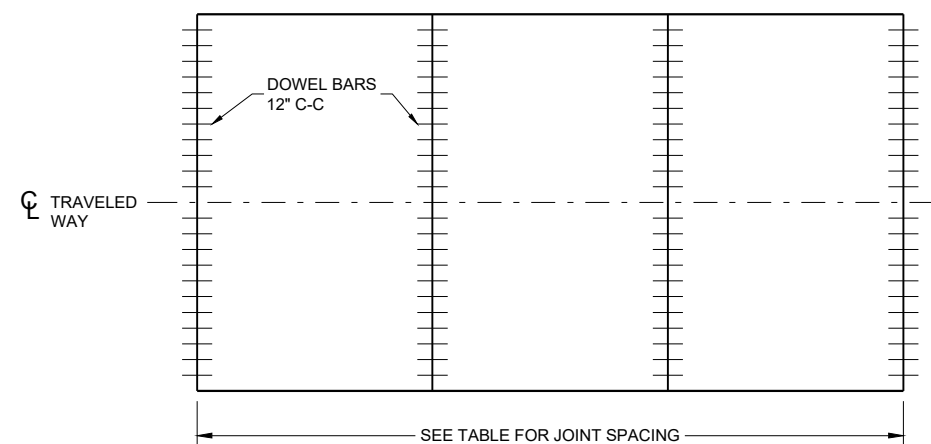

CONTRACTION JOINT LOCATIONS

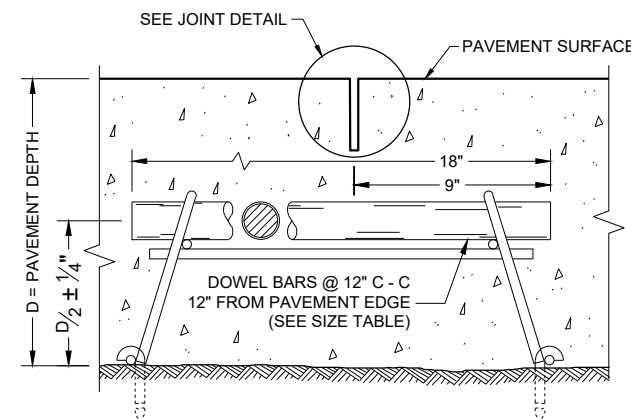

DOWELED CONTRACTION JOINT

PAVEMENT DEPTH, DOWEL BAR SIZE AND JOINT SPACING TABLE

PAVEMENT DEPTH (D)	DOWEL BAR DIAMETER	CONTRACTION JOINT SPACING
6", 6 1/2"	NONE	12'
7", 7 1/2"	1"	14'
8" & ABOVE	1 1/4"	15'

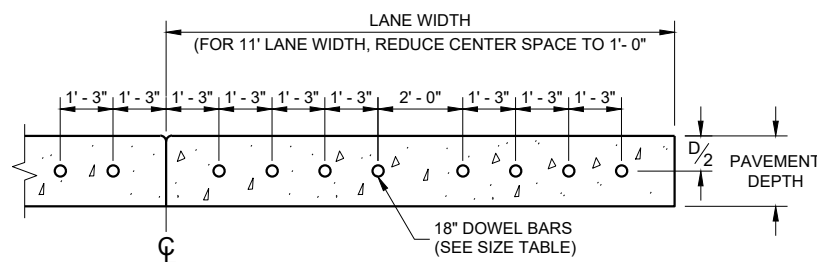

DRILLED DOWEL BAR CONSTRUCTION JOINT ⑦

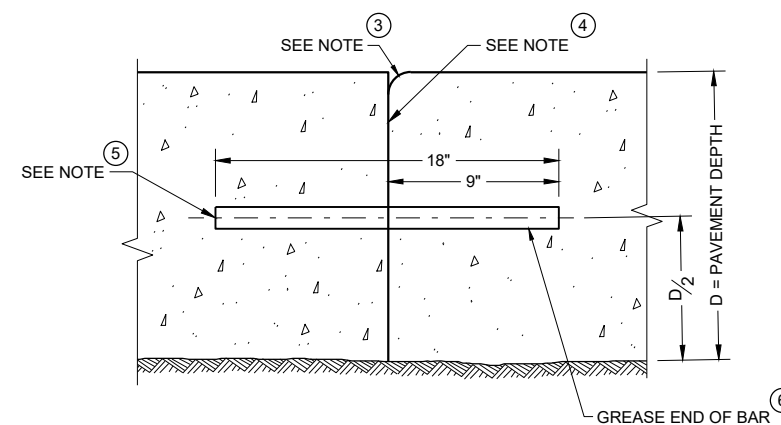

TRANSVERSE CONSTRUCTION JOINT

URBAN DOWELED CONCRETE PAVEMENT

STATE OF WISCONSIN
DEPARTMENT OF TRANSPORTATION

APPROVED
November 2022 /S/ Peter Kemp P.E.
DATE PAVEMENT SUPERVISOR
FHWA

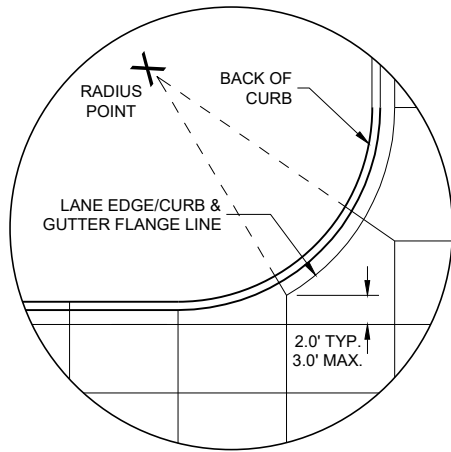

DETAIL "A"

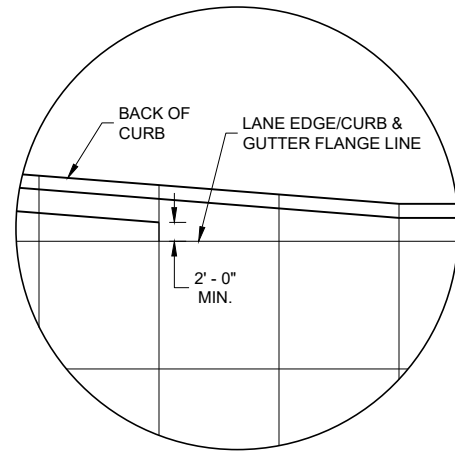

DETAIL "B"

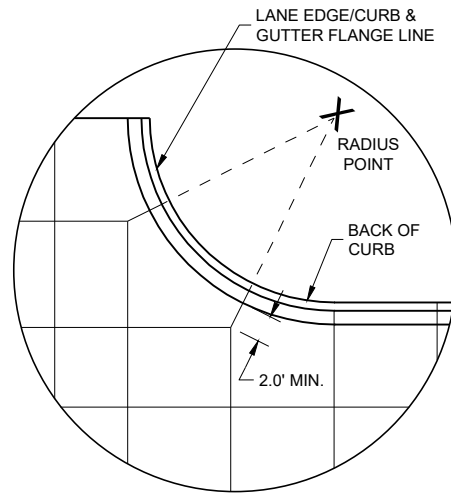

DETAIL "C"

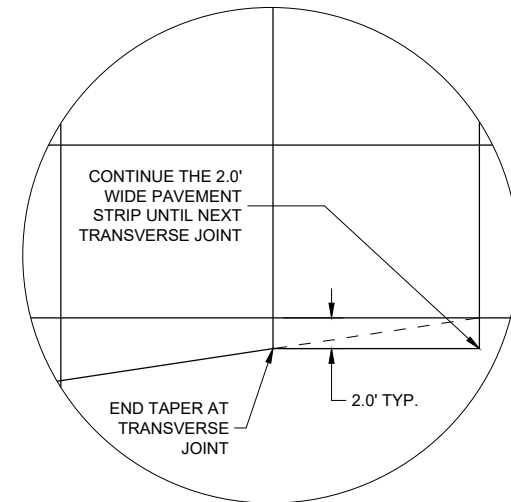

DETAIL "D"

GENERAL NOTES

- THE PRIMARY ROADWAY CONTROLS THE TRANSVERSE JOINT PATTERN.
- ALIGN NEW JOINTS WITH EXISTING JOINTS OR CRACKS.
- CONSTRUCT TRANSVERSE JOINTS PERPENDICULAR TO THE ROADWAY.
- ADJUST TRANSVERSE JOINTS TO ALIGN WITH UTILITY FIXTURES (E.G. MANHOLES AND INLETS) IN THE PAVEMENT STRUCTURE WHEN POSSIBLE. WATER VALVES DO NOT REQUIRE JOINT ADJUSTMENT.
- AVOID SLABS LESS THAN 2 FEET WIDE OR GREATER THAN 15 FEET WIDE.
- SEE TABLE FOR TRANSVERSE JOINT SPACING. JOINT SPACING SPECIFIED IS MAXIMUM AND ACTUAL SPACING CAN BE ADJUSTED TO ACCOMMODATE INTERSECTIONS.
- AVOID ANGLES LESS THAN 60° BY DOGLEGGING JOINTS THROUGH CURVE RADIUS POINTS. USE 90° ANGLES WHEN POSSIBLE.
- CORRELATE LONGITUDINAL JOINTS WITH LANE LINES WHEN POSSIBLE.

- ① PROVIDE TRANSVERSE JOINTS AT ALL PAVEMENT WIDTH CHANGES.
- ② CONSTRUCT DOWELED EXPANSION JOINT ON THE SIDE ROAD OF AN INTERSECTION IF THE SIDE ROAD IS CONCRETE PAVEMENT AND GREATER THAN 300 FEET IN LENGTH. ALIGN EXPANSION JOINT WITH EDGE OF RADIUS.
- ③ THE ENGINEER MAY APPROVE SLIGHT VARIATIONS FROM THESE JOINTING DETAILS.

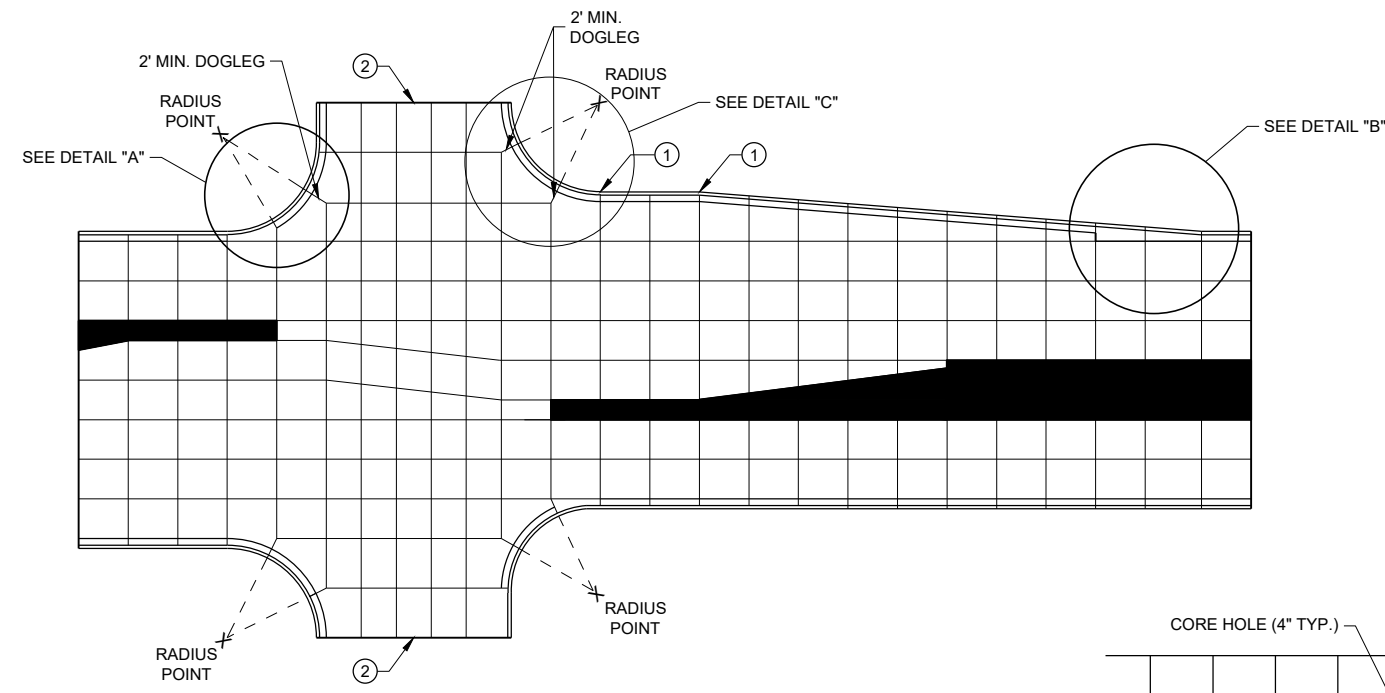

STANDARD INTERSECTION

PAVEMENT DEPTH AND JOINT SPACING TABLE

PAVEMENT DEPTH (D)	CONTRACTION JOINT SPACING
6", 6 1/2"	12'
7", 7 1/2"	14'
8" & ABOVE	15'

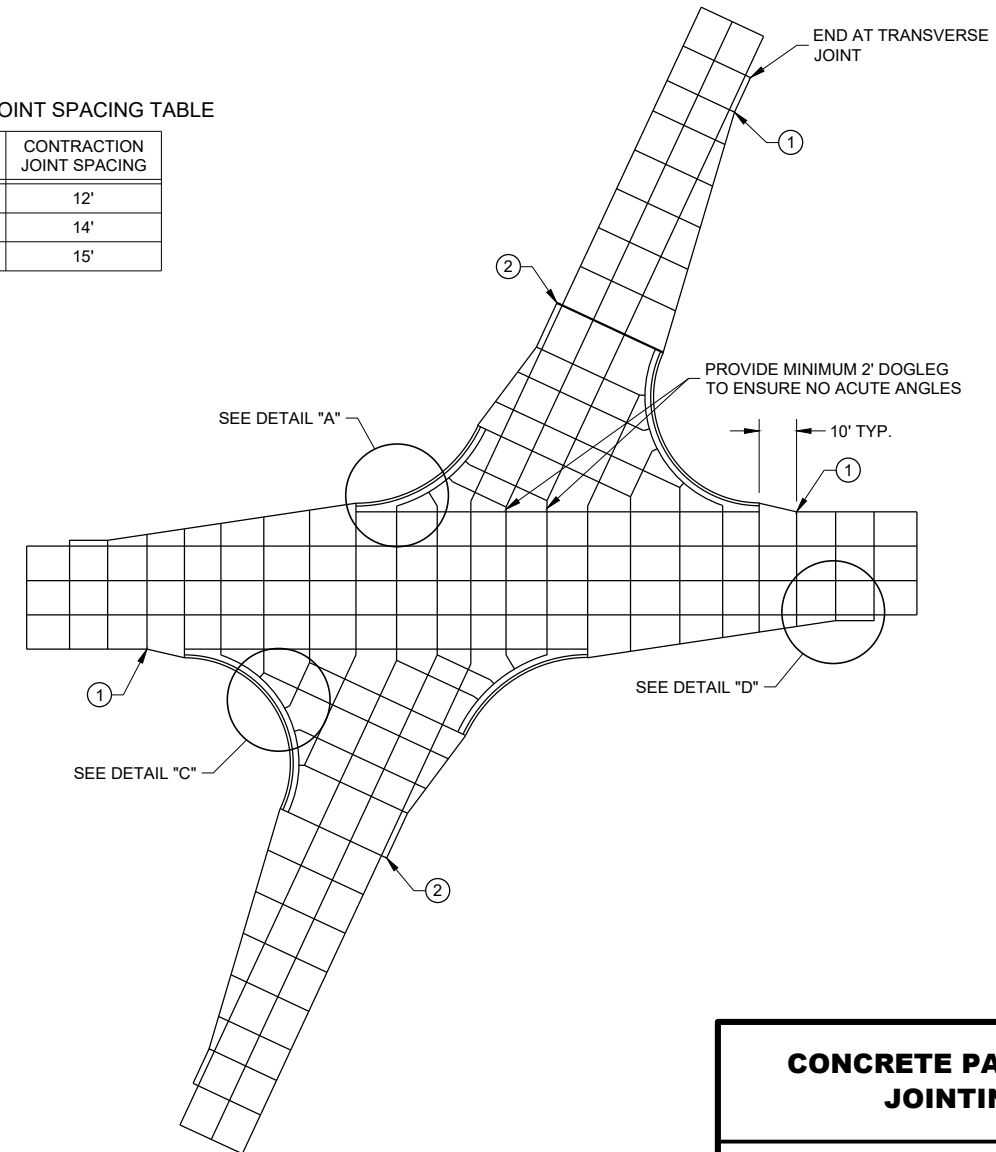

SKEWED INTERSECTION

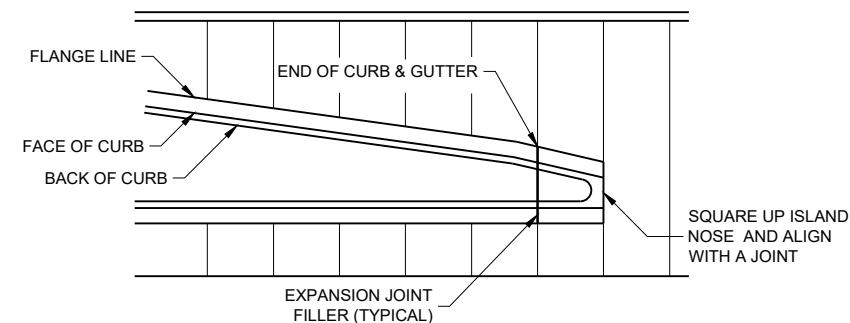

APPROACH TO MEDIAN

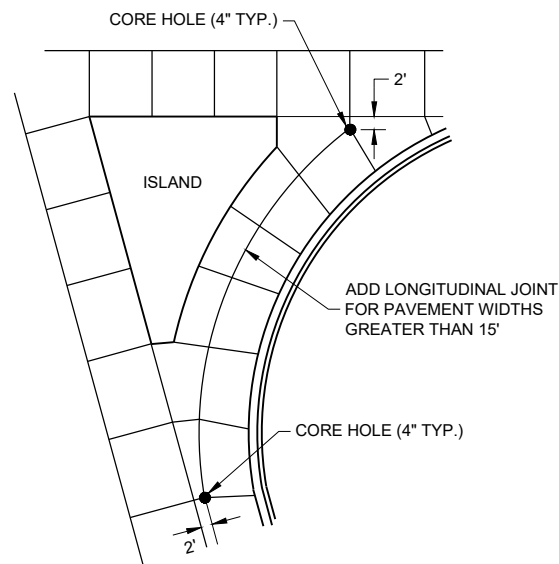

LARGE RIGHT TURN

LEGEND

- POTENTIAL DOWELED EXPANSION JOINT
- - - DOWELED JOINT
- TIED JOINT

GENERAL NOTES

USE AN EXPANSION JOINT FILLER MEETING THE REQUIREMENTS OF STANDARD SPECIFICATION 415.

6

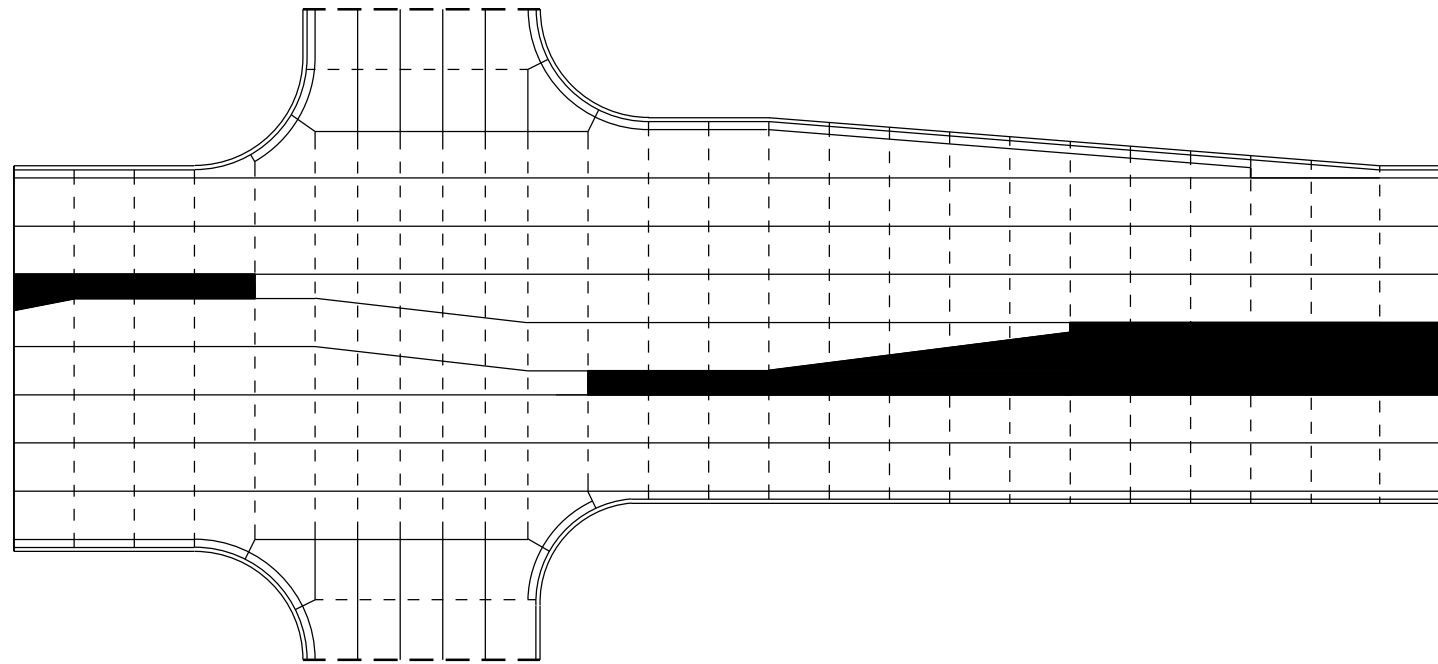

STANDARD INTERSECTION

6

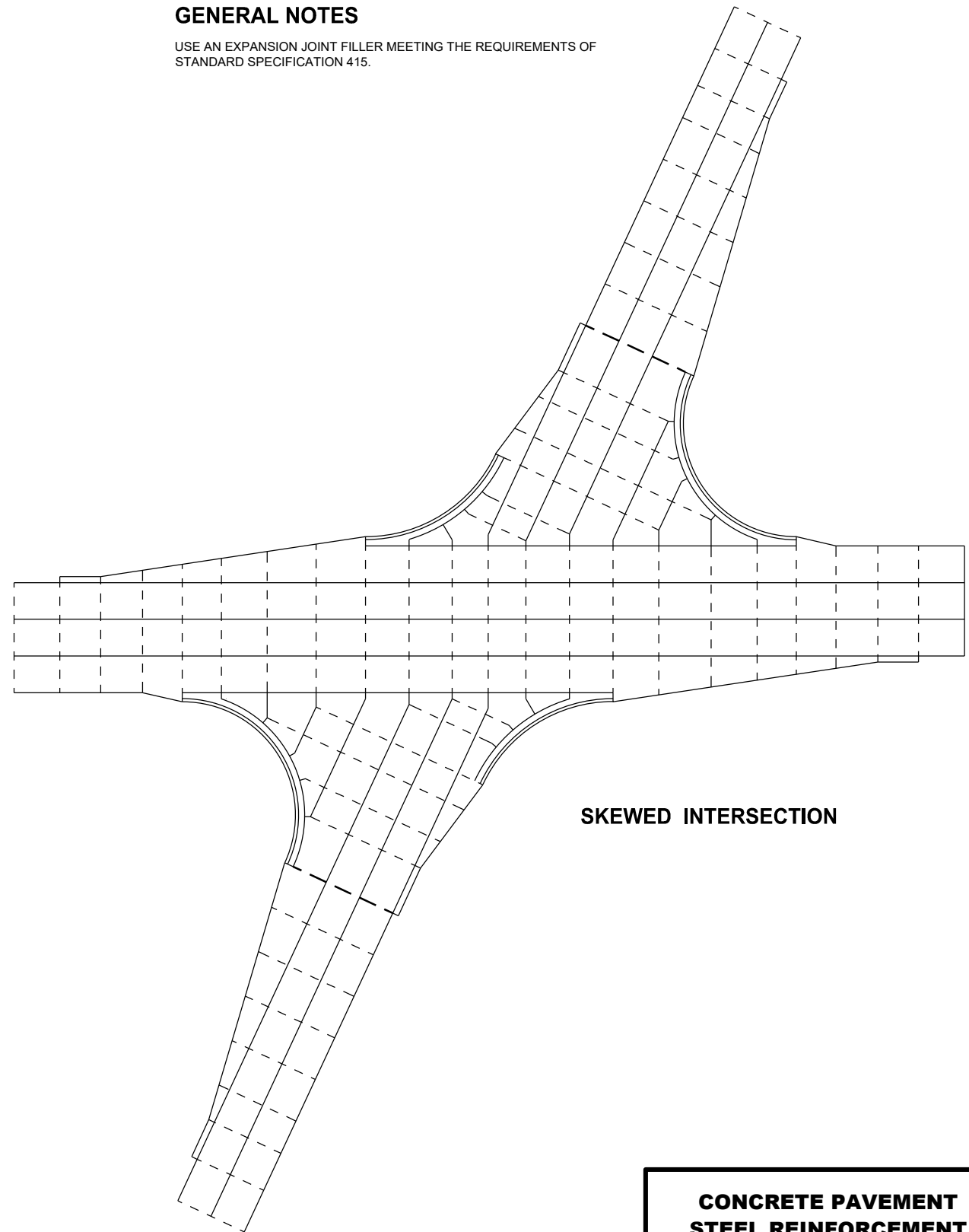

SKewed INTERSECTION

**CONCRETE PAVEMENT
STEEL REINFORCEMENT**

STATE OF WISCONSIN
DEPARTMENT OF TRANSPORTATION

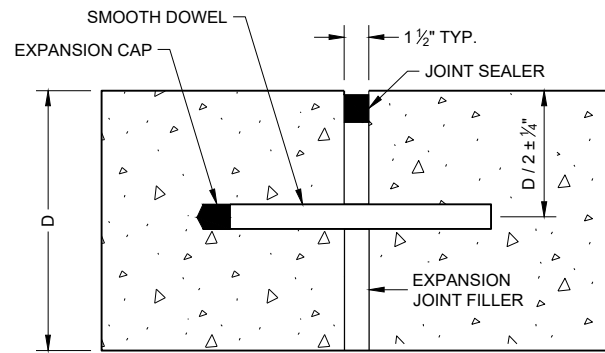

DOWELED TRANSVERSE ①

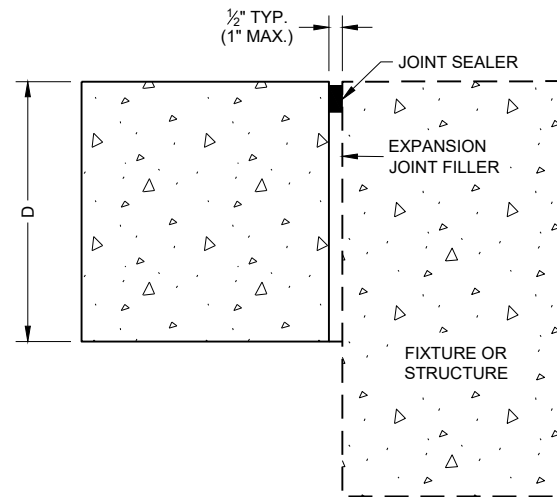

UNTIED - LONGITUDINAL

EXPANSION JOINTS

TIE BAR TABLE

PAVEMENT DEPTH (D)	TIE BAR SIZE	TIE BAR LENGTH (L)	MAX. TIE BAR SPACING
< 10 1/2"	NO. 4	30"	36"
≥ 10 1/2"	NO. 5	36"	36"
	NO. 4*	30"	24" **

* SUBSTITUTE BENT BARS AT LONGITUDINAL JOINTS WHEN EQUIPMENT LIMITATIONS DURING CONSTRUCTION WARRANT (e.g. AUXILIARY LANES OR TURN LANES)

** CONFORM TO 15" MINIMUM SPACING FROM TRANSVERSE JOINTS; SPACING BETWEEN TIE BARS WILL BE 30" AT TRANSVERSE JOINTS.

GENERAL NOTES

- ① USE DOWELED EXPANSION JOINTS ON SIDE ROADS AT INTERSECTIONS (TO ISOLATE THE SIDE ROAD FROM THE THROUGH STREET) IF THE SIDE ROAD IS CONCRETE PAVEMENT AND GREATER THAN 300 FEET IN LENGTH.
- ② SPACE CONTRACTION JOINTS IN ACCORDANCE WITH SDD 13C4, 13C11 OR 13C13.
- ③ LOCATE CONSTRUCTION JOINTS A MINIMUM OF 6 FEET FROM THE NEAREST CONTRACTION JOINT AND ALIGN PARALLEL TO CONTRACTION JOINTS.
- ④ CONSTRUCTION JOINTS CAN BE FORMED OR SAWED.
- ⑤ IF JOINT IS FORMED, PROVIDE A 1/4" RADIUS.
- ⑥ ANCHOR TIE BARS INTO DRILLED HOLES WITH AN EPOXY.

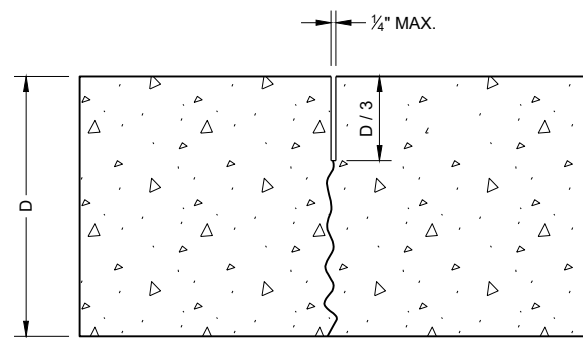

UNDOWELED TRANSVERSE

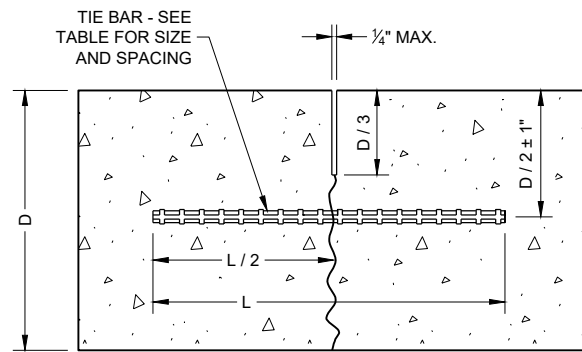

TIED LONGITUDINAL

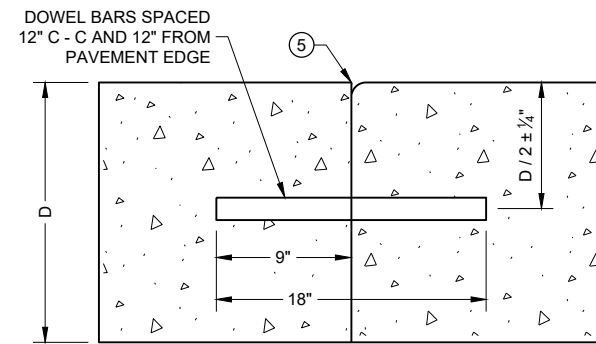

DOWELED TRANSVERSE ③

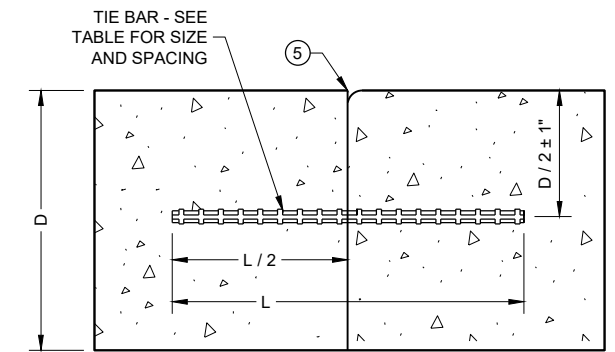

TIED LONGITUDINAL

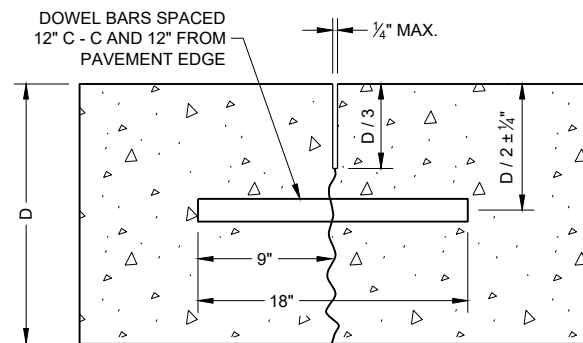

DOWELED TRANSVERSE

CONTRACTION JOINTS ②

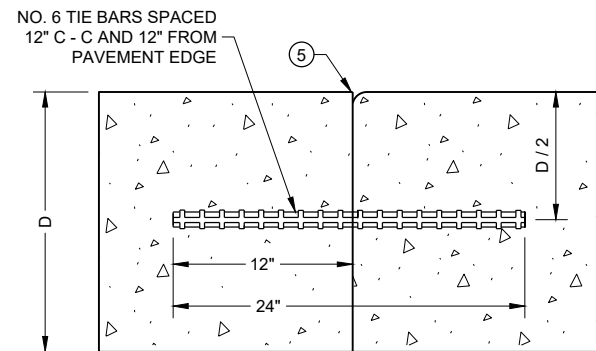

TIED TRANSVERSE ③
(FOR USE ON NON-DOWELED PAVEMENTS ONLY)

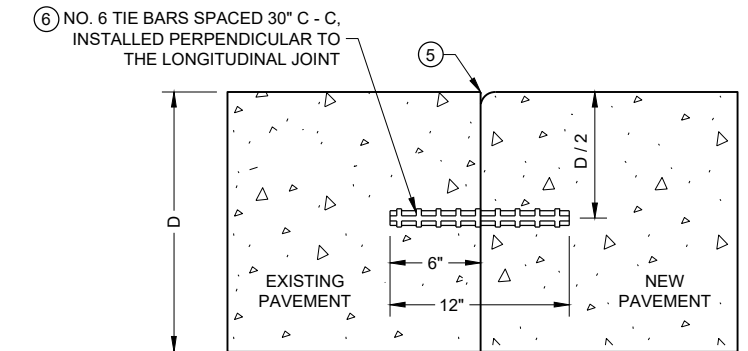

TIED LONGITUDINAL TO EXISTING

CONSTRUCTION JOINTS ④

**CONCRETE PAVEMENT
JOINT TYPES**

STATE OF WISCONSIN
DEPARTMENT OF TRANSPORTATION

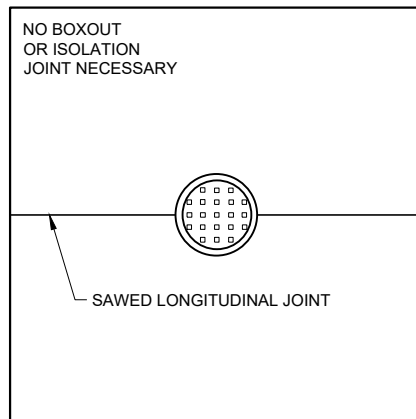

MANHOLE WITH LONGITUDINAL JOINT

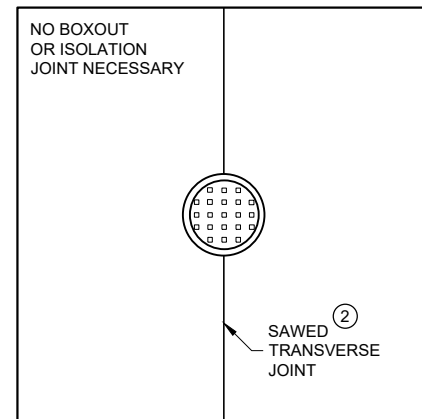

MANHOLE WITH TRANSVERSE JOINT

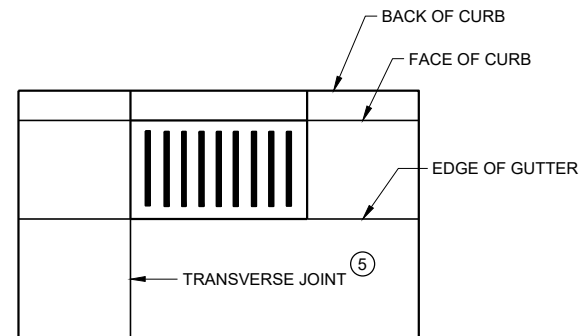

INLET WITH TRANSVERSE JOINT

GENERAL NOTES

- ① USE BOXOUTS WHEN UTILITY STRUCTURE IS IN THE PATH OF CONSTRUCTION JOINTS. PROVIDE A 1 FOOT MINIMUM CLEARANCE BETWEEN THE EXTERIOR LIMIT OF THE STRUCTURE TO THE DIAMOND BOXOUT.
- ② ADJUST TRANSVERSE JOINT TO INTERSECT MANHOLE IF POSSIBLE.
- ③ IF DISTANCE BETWEEN THE LONGITUDINAL JOINT AND THE EDGE OF MANHOLE IS 2 FEET OR LESS, DIVERT THE LONGITUDINAL JOINT AT A 2:1 TAPER RATE TO THE CENTER OF THE MANHOLE. IF THE DISTANCE IS GREATER THAN 2 FEET, DO NOT DIVERT THE JOINT AND SAW AS NORMAL. PLACE REINFORCEMENT REBAR AROUND THE MANHOLE.
- ④ IF THE DISTANCE FROM THE EDGE OF THE MANHOLE TO THE NEAREST TRANSVERSE JOINT IS LESS 4 FEET OR LESS, REDIRECT JOINT TO INTERSECT THE CENTER OF THE MANHOLE. IF DISTANCE IS GREATER THAN 4 FEET, DO NOT DIVERT THE JOINT AND SAW AS NORMAL. PLACE REINFORCEMENT REBAR AROUND THE MANHOLE.
- ⑤ ALIGN TRANSVERSE JOINT WITH ONE EDGE OF INLET WHEN PRACTICAL.

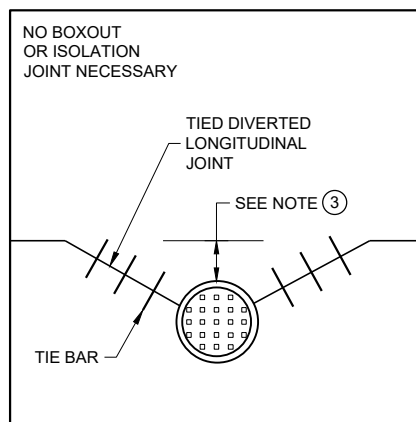

MANHOLE WITH DIVERTED LONGITUDINAL CONTRACTION JOINT

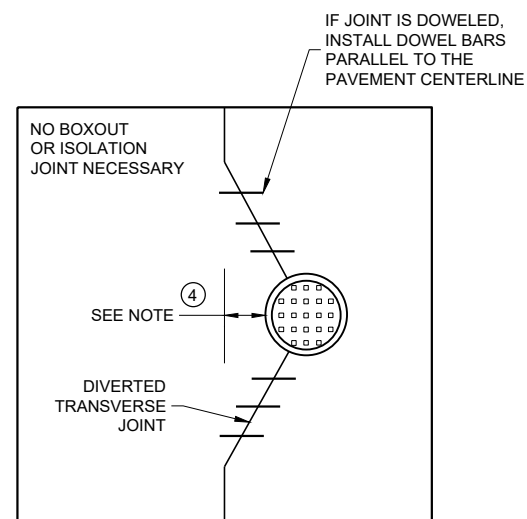

MANHOLE WITH DIVERTED TRANSVERSE CONTRACTION JOINT

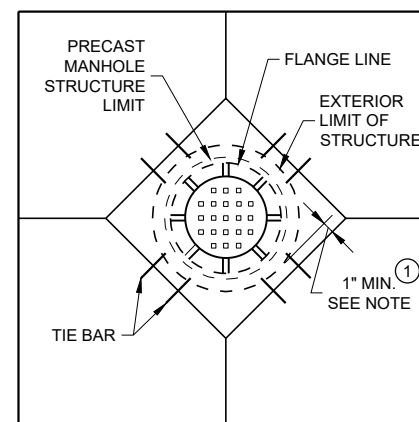

DIAGONAL MANHOLE BOXOUT FOR CONSTRUCTION JOINTS

CONCRETE PAVEMENT JOINTING AT UTILITY FIXTURES

STATE OF WISCONSIN DEPARTMENT OF TRANSPORTATION

APPROVED
 May 2023 /S/ Peter Kemp P.E.
 DATE PAVEMENT SUPERVISOR

FHWA

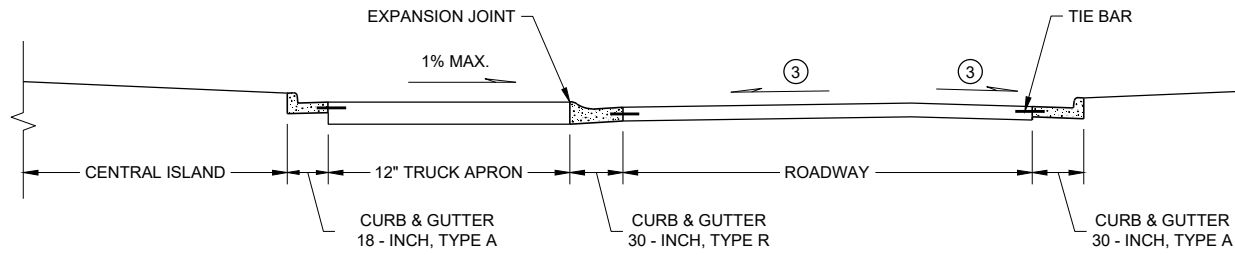

SECTION A - A

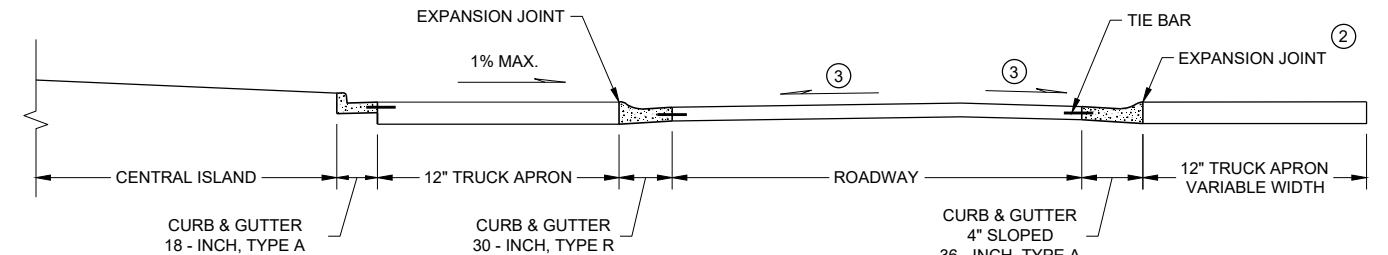

SECTION B - B

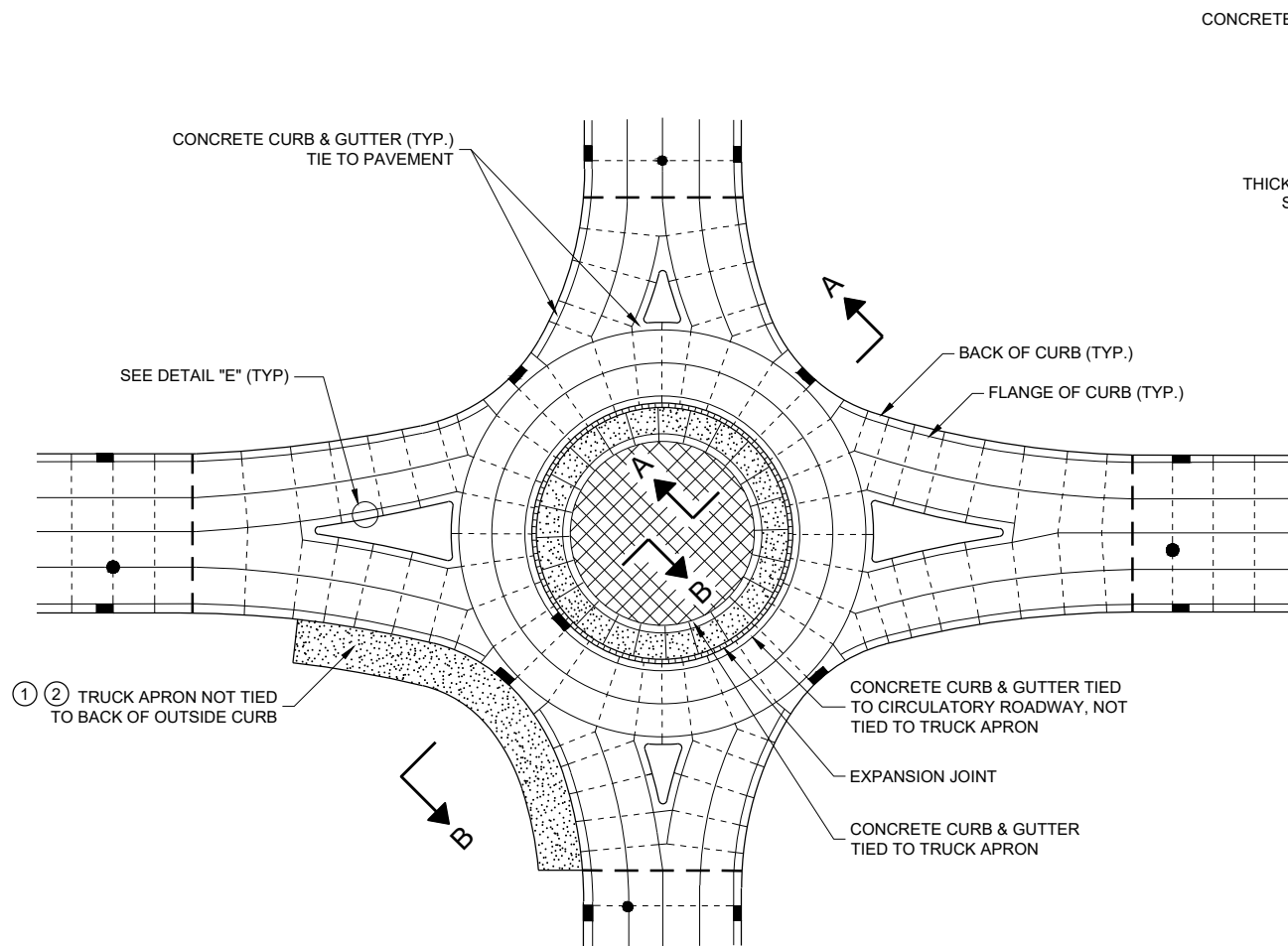

ISOLATED CIRCLE JOINT LAYOUT FOR ROUNDABOUTS

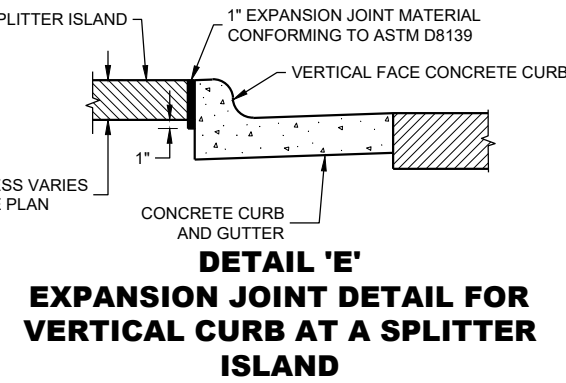

**DETAIL 'E'
EXPANSION JOINT DETAIL FOR
VERTICAL CURB AT A SPLITTER
ISLAND**

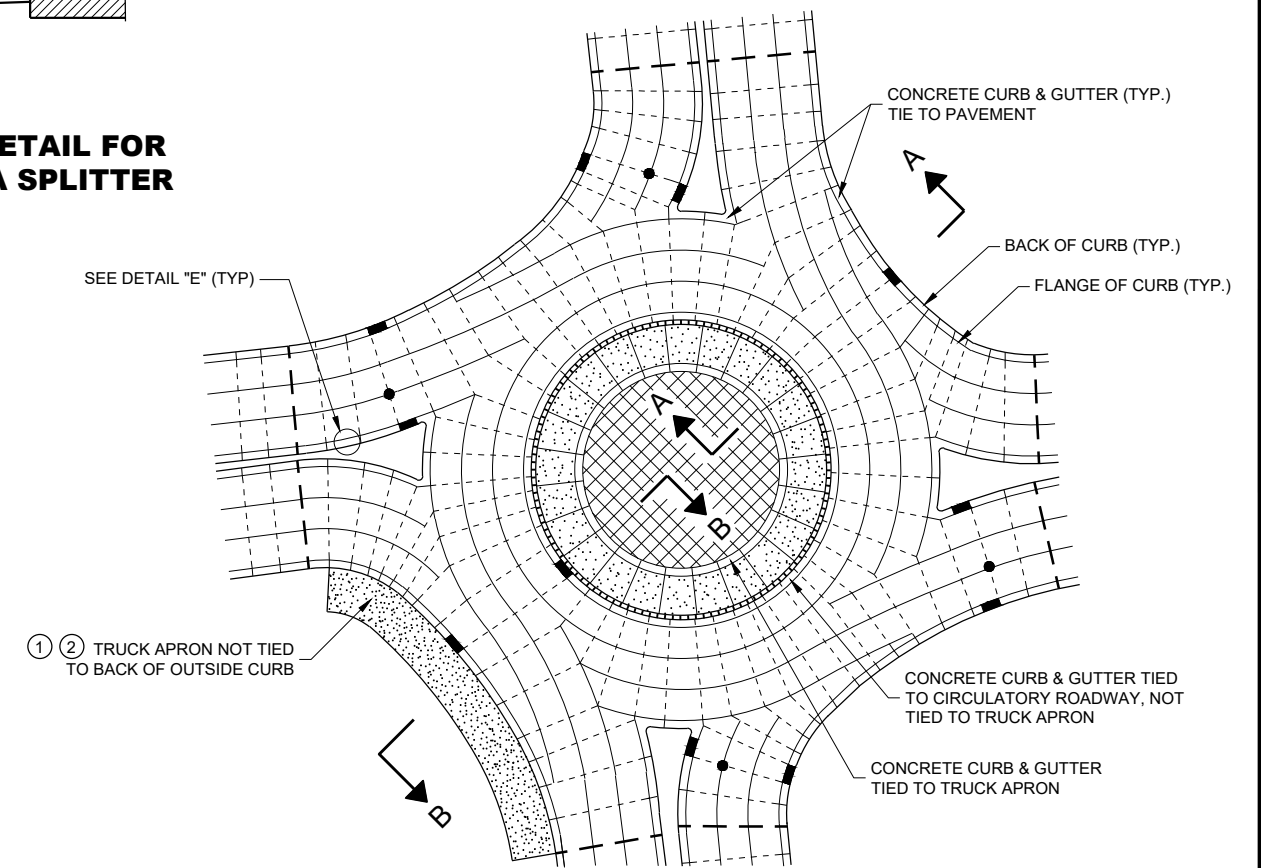

PINWHEEL JOINT LAYOUT FOR ROUNDABOUTS

GENERAL NOTES

MAXIMUM JOINT SPACING IS IN ACCORDANCE WITH THE TABLE SHOWN ON SDD 13C18 - SHEET "a"
 USE EXPANSION JOINT FILLER MEETING THE REQUIREMENTS OF STANDARD SPECIFICATION 415.
 DO NOT DOWEL OR TIE THE TRUCK APRON TRANSVERSE JOINTS.

- ① DESIGNER DETERMINES SIZE AND LOCATION(S) OF TRUCK APRON TO ACCOMMODATE TRACKING OF OVERSIZE / OVERWEIGHT VEHICLES.
- ② TIE THE OUTSIDE TRUCK APRON TO THE BACK SIDE OF CURB ONLY WHEN ENTIRE TRUCK APRON IS LESS THAN 3 FEET.
- ③ CONFORM TO PLAN CONSTRUCTION DETAILS FOR CIRCULATORY ROADWAY CROSS SLOPE.

LEGEND

- DOWELED JOINT
- TIED JOINT
- ===== EXPANSION JOINT
- — — — — POTENTIAL DOWELED EXPANSION JOINT
- [Pattern] TRUCK APRON
- [Pattern] CENTRAL ISLAND
- ● UTILITY STRUCTURES

**CONCRETE PAVEMENT JOINTING
AND STEEL REINFORCEMENT
IN ROUNDABOUTS**

STATE OF WISCONSIN
DEPARTMENT OF TRANSPORTATION

APPROVED
May 2023 /S/ Peter Kemp P.E.
DATE DATE PAVEMENT SUPERVISOR

FHWA

LEGEND

- DOWELED JOINT
- TIED JOINT
- ▨▨▨▨ EXPANSION JOINT
- — — — POTENTIAL DOWELED ^① EXPANSION JOINT
- ← DIRECTION OF TRAFFIC

GENERAL NOTES

- ① CONSTRUCT DOWELED EXPANSION JOINT ON THE SIDE ROAD OF AN INTERSECTION IF THE SIDE ROAD IS CONCRETE PAVEMENT AND GREATER THAN 300 FEET IN LENGTH. ALIGN EXPANSION JOINT WITH THE EDGE OF RADIUS.
- ② PROVIDE TIED JOINT AT THE FLANGE OF SCAB ON CURB IF SCAB ON CURB AND GUTTER IS USE.

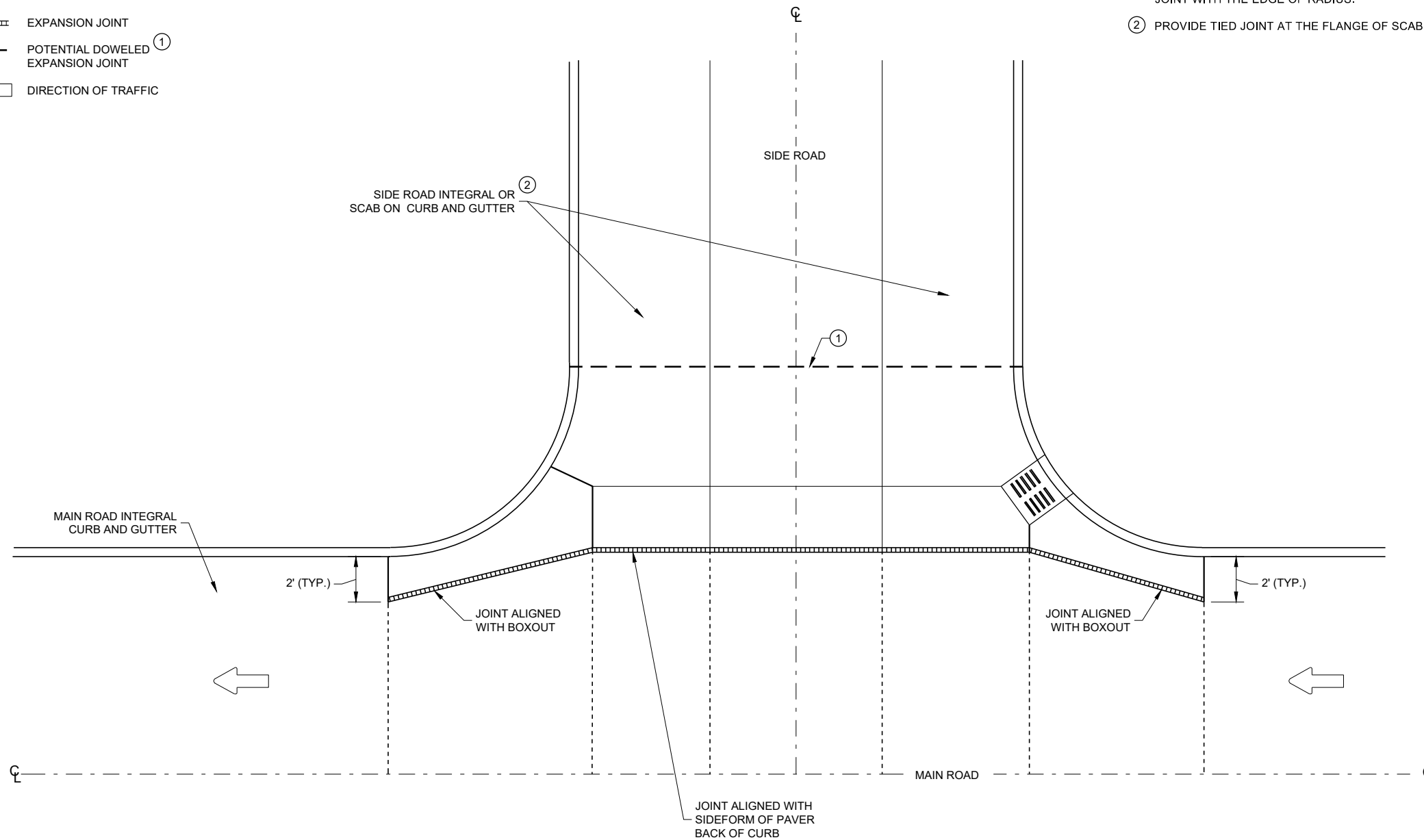

INTERSECTION BOXOUT FOR INTEGRAL CURB AND GUTTER

CONCRETE PAVEMENT INTERSECTION BOXOUT FOR INTEGRAL CURB AND GUTTER	
STATE OF WISCONSIN DEPARTMENT OF TRANSPORTATION	
APPROVED May 2023 DATE	/S/ Peter Kemp P.E. PAVEMENT SUPERVISOR
FHWA	

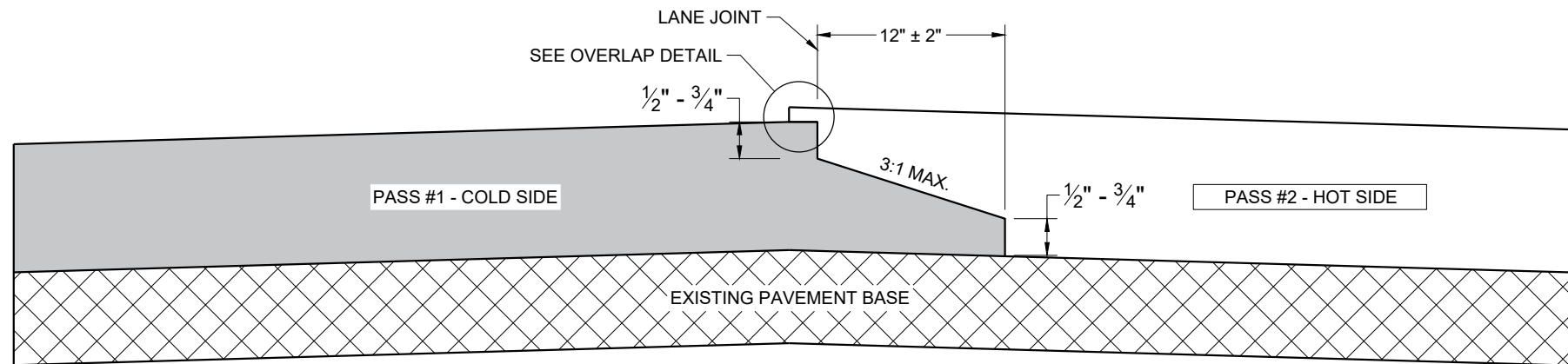

**TYPICAL PAVEMENT CROSS SECTION
NOTCHED WEDGE JOINT**

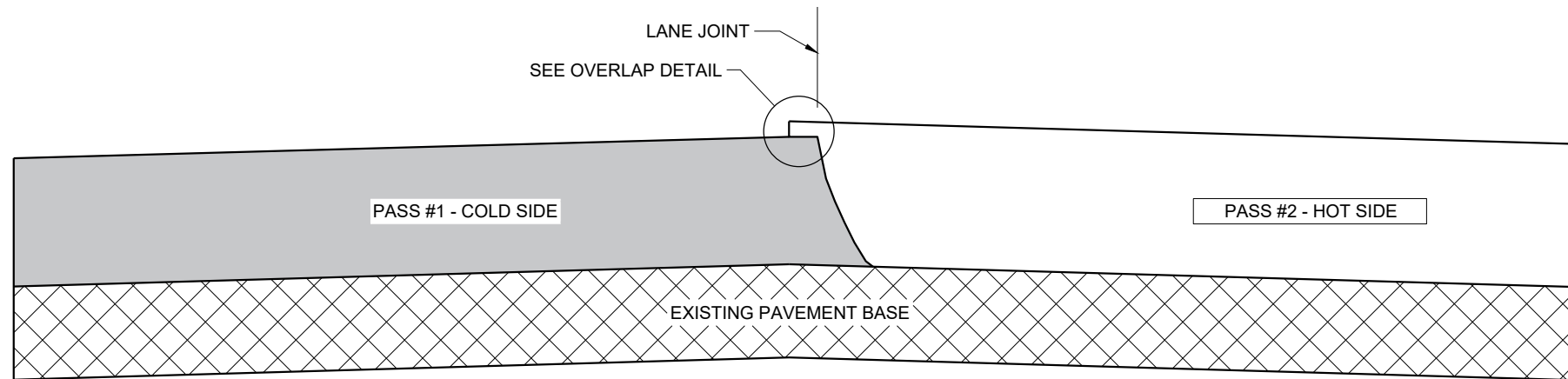

**TYPICAL PAVEMENT CROSS SECTION
VERTICAL JOINT**

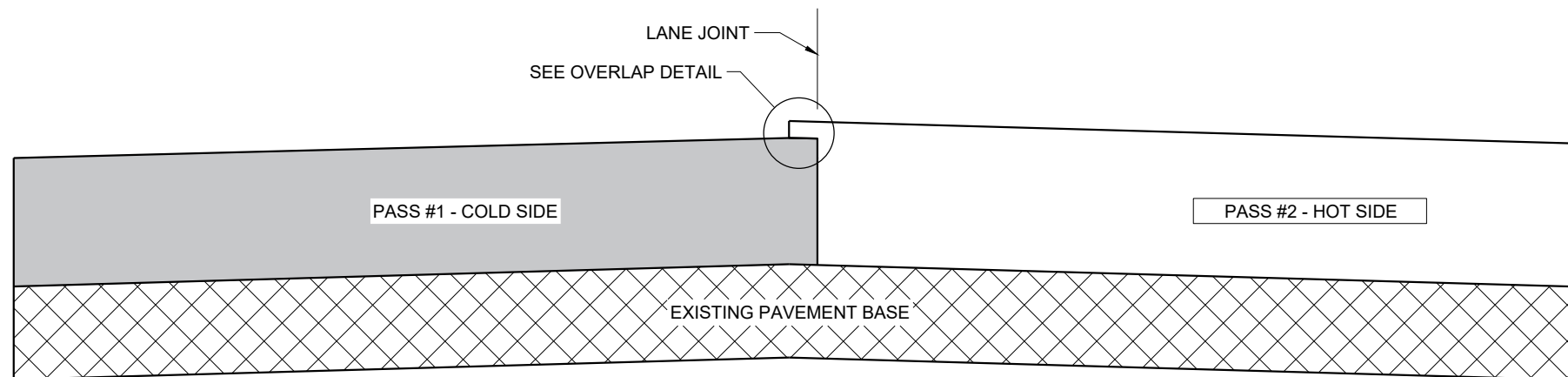

**TYPICAL PAVEMENT CROSS SECTION
VERTICAL JOINT (MILLED)**

GENERAL NOTES

IN ADDITION TO THE DETAILS PROVIDED IN THIS DRAWING, CONFORM TO STANDARD SPECIFICATION 450.3.2.8 FOR WHEN A NOTCHED WEDGE JOINT IS REQUIRED AND FOR GENERAL JOINT CONSTRUCTION REQUIREMENTS.

FOR ALL LONGITUDINAL JOINTS, ENSURE THE PAVER SCREED OVERLAPS THE PREVIOUSLY PLACED PAVEMENT BY $1" \pm 0.5"$ AND THE HOT SIDE OF THE JOINT REMAINS HIGHER THAN THE COLD SIDE BY APPROXIMATELY 0.1" AFTER FINAL COMPACTION. (IT WILL BE FLUSH WHEN PAVING IN ECHELON.)

ONLY REMOVE THE LONGITUDINAL NOTCHED WEDGE JOINT FOR SMA PAVEMENT OR AS DIRECTED BY THE ENGINEER TO ADDRESS SPECIFIC LENGTHS OF JOINT DAMAGED BY TRAFFIC.

WHEN MILLING BACK OR REMOVING ANY LONGITUDINAL JOINT, LIMIT THE MATERIAL REMOVED TO 2" FROM THE TOP NOTCH OR FROM THE VERTICAL JOINT EDGE ON THE COLD SIDE OF THE JOINT.

USE LONGITUDINAL MILLED JOINT AS PLANS SHOW OR THE AS THE ENGINEER DIRECTS.

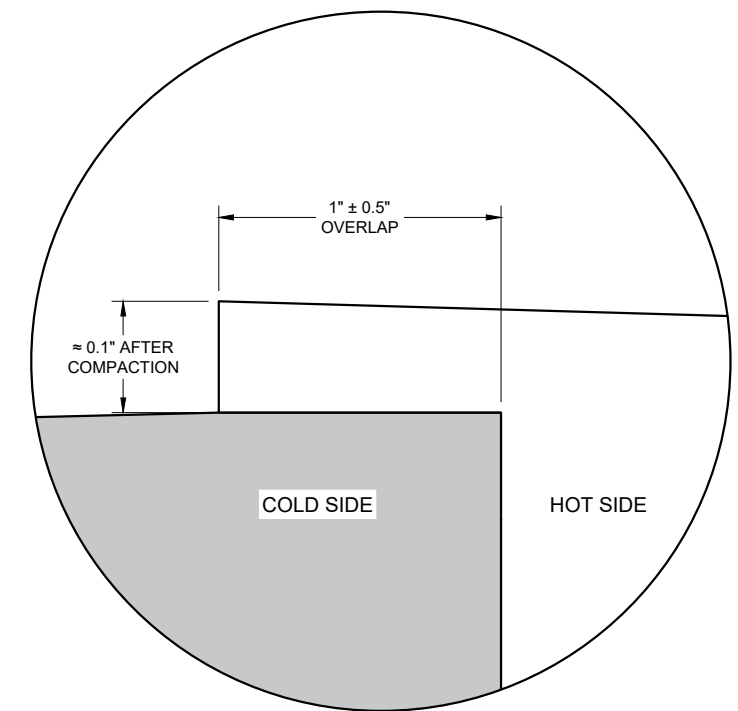

OVERLAP DETAIL (TYPICAL)

6

6

SDD 13C19 - 03

SDD 13C19 - 03

HMA LONGITUDINAL JOINTS	
STATE OF WISCONSIN DEPARTMENT OF TRANSPORTATION	
APPROVED November 2020 DATE	/S/ Steven Hefel HMA PAVEMENT ENGINEER
FHWA	

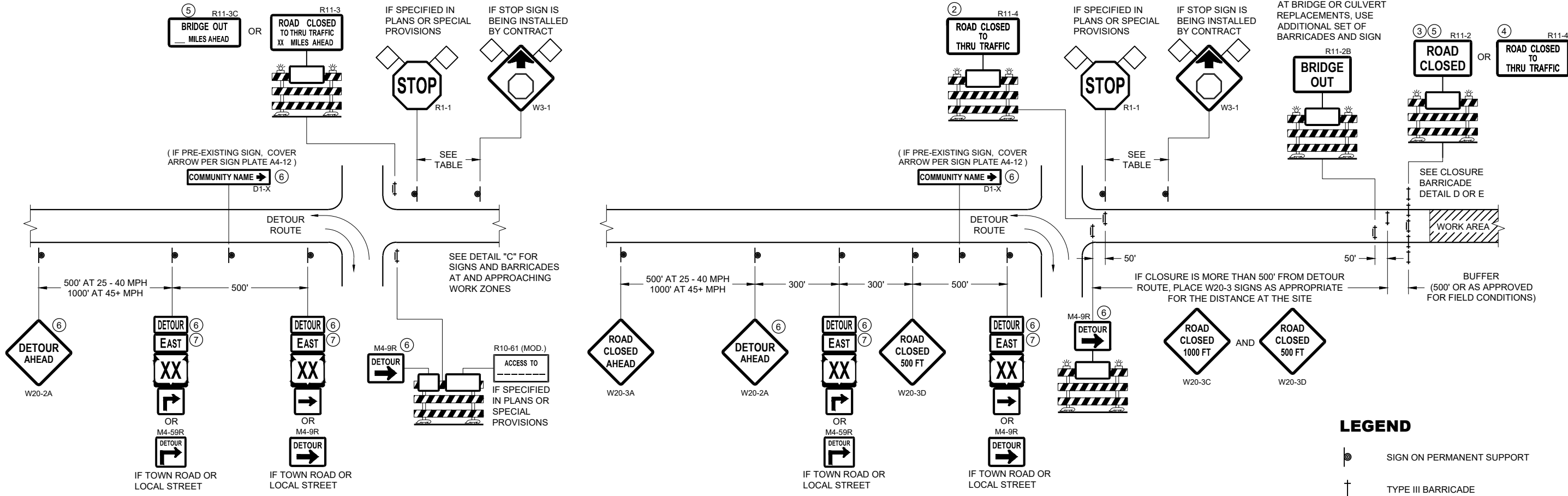

**DETAIL A
MAINLINE CLOSURE WITH POSTED DETOUR**

WORK ZONE GREATER THAN OR EQUAL TO 1/2 MILE FROM
DETOUR ROUTE (1000 FEET IF URBAN)

**DETAIL B
MAINLINE CLOSURE WITH POSTED DETOUR**

WORK ZONE LESS THAN 1/2 MILE FROM
DETOUR ROUTE (1000 FEET IF URBAN)

- LEGEND**
- SIGN ON PERMANENT SUPPORT
 - TYPE III BARRICADE
 - TYPE III BARRICADE WITH ATTACHED SIGN
 - TYPE "A" WARNING LIGHT (FLASHING)
 - WORK AREA
 - FLAGS, 16" X 16" MIN. (ORANGE)

SPEED LIMIT (MPH)	"STOP AHEAD" ADVANCE WARNING DISTANCE (FT)
25	200
30	200
35	350
40	350
45	500
50	550
55	750

- M4 - 8
- M3 - X
- M1 - 4
- M1 - 6
- M1 - 5A
- M05 - 1
- M06 - 1

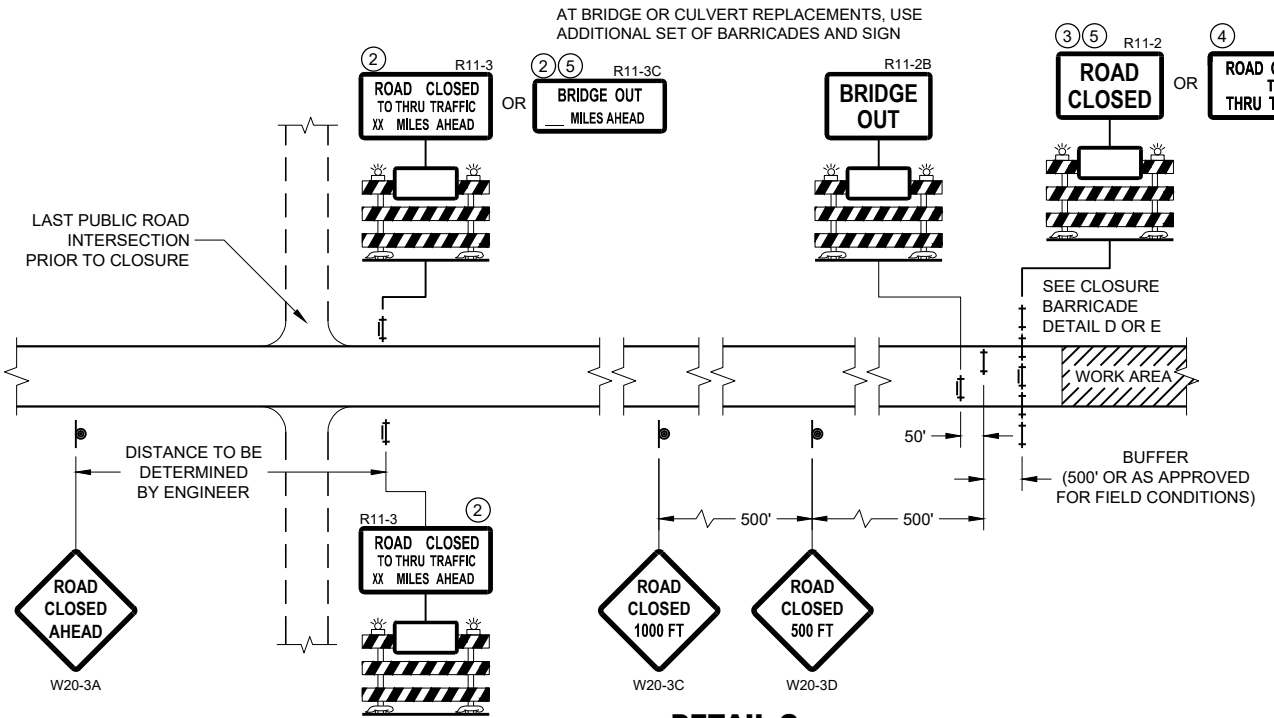

**DETAIL C
MAINLINE CLOSURE, NO POSTED DETOUR**

SEE SDD 15C2-SHEET "b"
FOR GENERAL NOTES
AND FOOTNOTES ① THROUGH ⑦

**BARRICADES AND SIGNS
FOR MAINLINE CLOSURES**

STATE OF WISCONSIN
DEPARTMENT OF TRANSPORTATION

APPROVED
May 2023 /S/ Andrew Heidtke
DATE DATE WORK ZONE ENGINEER

FHWA

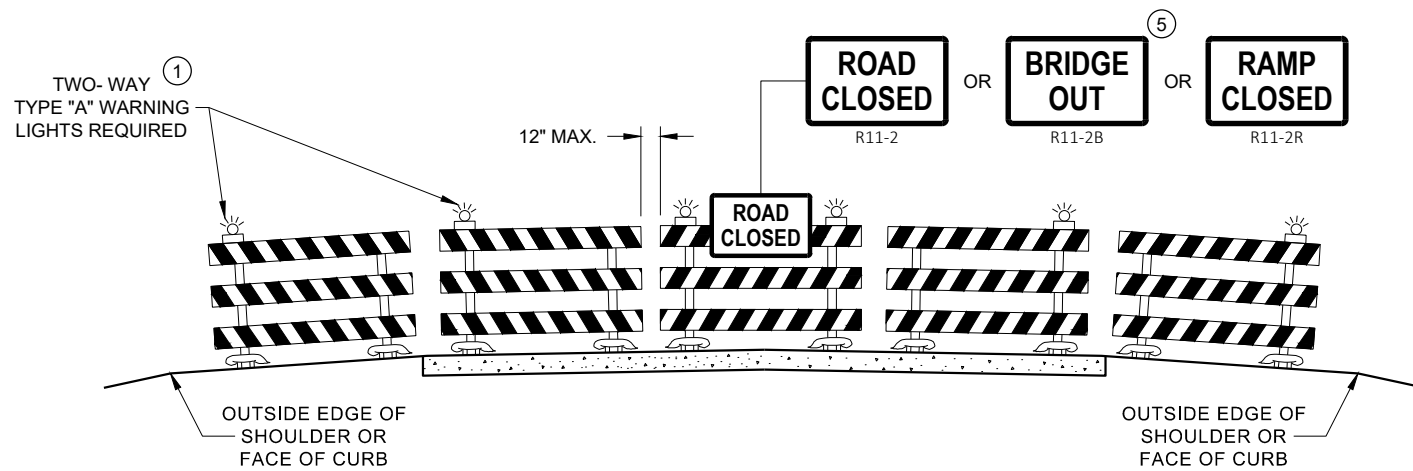

**DETAIL D
ROAD CLOSURE BARRICADE DETAIL
APPROACH VIEW**

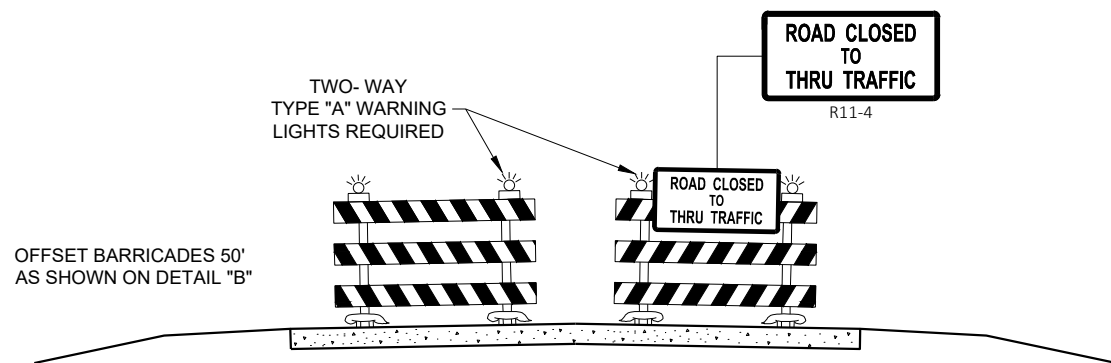

**DETAIL E
LANE CLOSURE BARRICADE DETAIL
APPROACH VIEW**

SEE SDD 15C2 - SHEET "a" FOR LEGEND

GENERAL NOTES

THE EXACT NUMBER, LOCATION, AND SPACING OF ALL SIGNS AND BARRICADES SHALL BE ADJUSTED TO FIT FIELD CONDITIONS AS APPROVED BY THE ENGINEER.

ANY SIGNS TEMPORARY OR EXISTING, WHICH CONFLICT WITH TRAFFIC CONTROL "IN USE", SHALL BE REMOVED OR COVERED AS NEEDED AND AS APPROVED BY THE ENGINEER.

THE SPACING BETWEEN TRAFFIC CONTROL SIGNS SHOULD BE ADJUSTED TO NOT CONFLICT WITH AND SHOULD PROVIDE A DESIRABLE MINIMUM OF 200 FEET CLEARANCE TO EXISTING SIGNS THAT WILL REMAIN IN PLACE.

BARRICADES THAT MUST BE MOVED FOR A WORK OPERATION SHALL BE IMMEDIATELY RE-ESTABLISHED UPON COMPLETION OF THE OPERATION, OR FOR CONTINUING OPERATIONS, AT THE END OF EACH WORKING DAY.

SIGNS THAT WILL BE IN PLACE LESS THAN 7 CONTINUOUS DAYS AND NIGHTS MAY BE MOUNTED ON PORTABLE SUPPORTS.

ALL TYPE III BARRICADES SHALL HAVE RAILS REFLECTORIZED ON BOTH FACES. STRIPES SHALL BE PROPERLY SLOPED DOWN TOWARD THE TRAFFIC SIDE OR AS SHOWN IN THE ROAD CLOSURE BARRICADE DETAIL "D" FOR FULL ROAD CLOSURES.

TYPE "A" LOW - INTENSITY FLASHING WARNING LIGHTS SHALL BE VISIBLE ON BOTH SIDES OF THE BARRICADE.

THE R11 - 2, R11 - 3, M4 - 9, R11 - 4, AND R10 - 61 SIGNS PLACED ON THE BARRICADES SHALL COVER NO MORE THAN THE TOP RAIL. THE SIGNS SHALL NOT COVER ANY PORTION OF THE MIDDLE RAIL OR BOTTOM RAILS.

"WO" AND "MO" SIGNS ARE THE SAME AS "W" AND "M" SIGNS EXCEPT THE BACKGROUND IS ORANGE.

ALL SIGNS SHALL BE 48" X 48" UNLESS OTHERWISE NOTED BELOW:

- R11 - 2 SHALL BE 48" X 30"
- R11 - 3 SHALL, R11 - 4 AND R10 - 61 SHALL BE 60" X 30"
- M4 - 9 SHALL BE 30" X 24"
- M3 - X SHALL BE 24" X 12" (36" X 18" IF NEEDED TO MATCH EXISTING SIGNS)
- M4 - 8 SHALL BE 24" X 12" (36" X 18" IF NEEDED TO MATCH EXISTING SIGNS)
- M1 - 4, M1 - 5A AND M1 - 6 SHALL BE 24" X 24" (36" X 36" IF NEEDED TO MATCH EXISTING SIGNS)
- MO5 - 1 AND MO6 - 1 SHALL BE 21" X 21" (30" X 30" IF NEEDED TO MATCH EXISTING SIGNS)
- D1 - X SHALL BE AS SHOWN ON SPECIFIC PROJECT SIGNING DETAIL SHEETS.
- R1 - 1 SHALL BE 36" X 36"

- ① TWO WARNING LIGHTS SHALL BE PROVIDED ON THE CENTER BARRICADE AND A MINIMUM OF ONE WARNING LIGHT SHALL BE PROVIDED ON EACH OF THE OTHER BARRICADES WITHIN THE ROADWAY LIMITS. SPACING OF THE WARNING LIGHTS SHALL BE UNIFORM TO THE EDGE OF ROADWAY AS SHOWN (APPROX. 8 FOOT LIGHT SPACING).
- ② THESE SIGNS AND BARRICADES ARE NOT REQUIRED IF ROAD CLOSURE BEGINS AT AN INTERSECTION.
- ③ FOR ROAD CLOSURE WITHOUT LOCAL ACCESS TO PROJECT, SEE ROAD CLOSURE BARRICADE DETAIL "D".
- ④ FOR ROAD CLOSURE WITH LOCAL ACCESS TO PROJECT, SEE ROAD CLOSURE BARRICADE DETAIL "E".
- ⑤ FOR BRIDGE OR CULVERT REPLACEMENTS, SUBSTITUTE "BRIDGE OUT" INSTEAD OF "ROAD CLOSED" ON R11 - 2 AND R11 - 3 SIGNS.
- ⑥ INSTALL DETOUR AND COMMUNITY GUIDE SIGNS AND ARROWS ONLY IF SPECIFIED IN THE CONTRACT. IF THERE ARE EXISTING ROUTE MARKER ASSEMBLIES THAT WILL REMAIN IN PLACE, ADJUST THE LOCATION OF THE DETOUR ROUTE SIGNS TO CORRESPOND WITH THE EXISTING ASSEMBLIES. MODIFY EXISTING SIGNS WHERE POSSIBLE. SEE SPECIFIC PROJECT DETOUR SIGNING DETAIL SHEETS. IF DETOUR SIGNS ARE BEING INSTALLED BY OTHERS, PLACE THE CONTRACTED TRAFFIC CONTROL SIGNS TO ALLOW FOR PLACEMENT OF ALL WARNING, DETOUR AND GUIDE SIGNS AS SHOWN.
- ⑦ "EAST" CARDINAL DIRECTION MARKERS AND RIGHT TURN ARROWS ARE SHOWN. USE OTHER CARDINAL DIRECTIONS AND ARROWS AS APPROPRIATE.

**BARRICADES AND SIGNS
FOR
VARIOUS CLOSURES**

STATE OF WISCONSIN
DEPARTMENT OF TRANSPORTATION

APPROVED
May 2023 /S/ Andrew Heidtke
DATE WORK ZONE ENGINEER

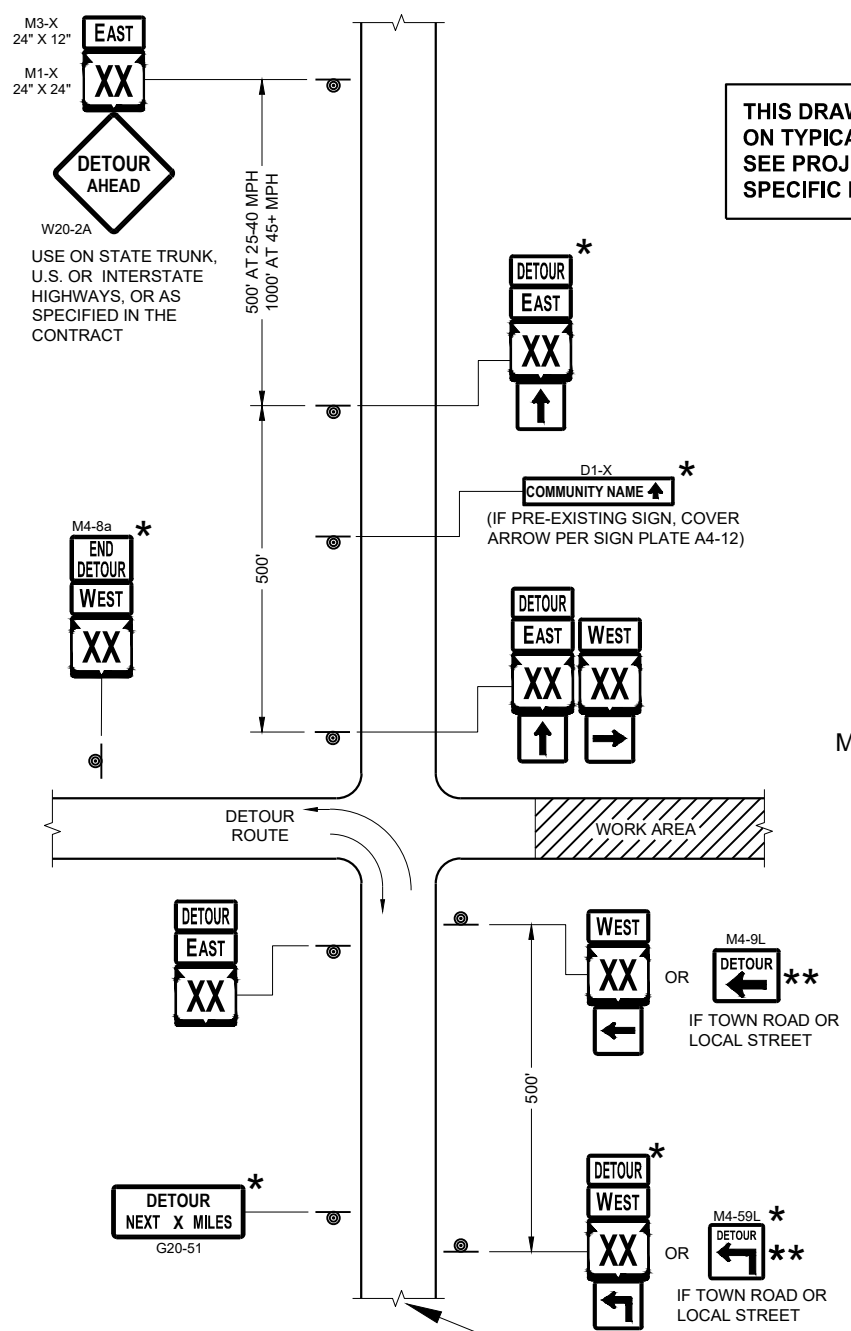

THIS DRAWING PROVIDES GENERAL GUIDANCE ON TYPICAL DETOUR SIGN LAYOUT AND SPACING. SEE PROJECT DETOUR SIGNING SHEETS FOR SPECIFIC DETAILS FOR EACH PROJECT.

LEGEND

- SIGN ON PERMANENT SUPPORT
- WORK AREA
- M4 - 8
- M3 - X
- M1 - 4
- M1 - 6
- M1 - 5A
- M05 - 1
- M06 - 1
- M06 - 1

GENERAL NOTES

THE EXACT NUMBER, LOCATION AND SPACING OF ALL SIGNS SHALL BE ADJUSTED TO FIT FIELD CONDITIONS AS APPROVED BY THE ENGINEER.

IF THERE ARE EXISTING ROUTE MARKER ASSEMBLIES THAT WILL REMAIN IN PLACE, ADJUST THE LOCATION OF THE DETOUR ROUTE SIGNS TO CORRESPOND WITH THE EXISTING ASSEMBLIES. SEE SPECIFIC PROJECT DETOUR SIGNING DETAIL SHEETS. MODIFY EXISTING SIGNS WHERE POSSIBLE.

THE SPACING BETWEEN TRAFFIC CONTROL AND DETOUR SIGNS SHOULD BE ADJUSTED TO NOT CONFLICT WITH AND TO PROVIDE A DESIRABLE MINIMUM OF 200 FEET CLEARANCE TO EXISTING SIGNS THAT WILL REMAIN IN PLACE.

ANY SIGNS TEMPORARY OR EXISTING, WHICH CONFLICT WITH TRAFFIC CONTROL "IN USE" SHALL BE REMOVED OR COVERED AS NEEDED AND AS APPROVED BY THE ENGINEER.

SIGNS THAT WILL BE IN PLACE LESS THAN 7 CONTINUOUS DAYS AND NIGHTS MAY BE MOUNTED ON PORTABLE SUPPORTS.

"MO" SIGNS ARE THE SAME AS "M" SIGNS EXCEPT THE BACKGROUND IS ORANGE.

SIGN SIZES SHALL BE AS FOLLOWS:

- M3-X SHALL BE 24" X 12" (36" X 18" IF NEEDED TO MATCH EXISTING SIGNS)
- M4-8 SHALL BE 24" X 12" (36" X 18" IF NEEDED TO MATCH EXISTING SIGNS)
- M1-4, M1-5A AND M1-6 SHALL BE 24" X 24" (36" X 36" IF NEEDED TO MATCH EXISTING SIGNS)
- M05-1 AND M06-1 SHALL BE 21" X 21" (30" X 30" IF NEEDED TO MATCH EXISTING SIGNS)
- M4-9 AND M4-59 SHALL BE 30" X 24"
- M4-8a SHALL BE 24" X 18"
- G20-51 SHALL BE 60" X 24"
- W20-2A SHALL BE 48" X 48"
- D1-X SHALL BE AS SHOWN ON SPECIFIC PROJECT SIGNING DETAIL SHEETS.

- * OPTIONAL SIGNS. SEE SPECIFIC PROJECT DETOUR SIGNING DETAIL SHEETS.
- ** FOR A TOWN ROAD OR LOCAL STREET DETOURED ONTO A STATE TRUNK HIGHWAY, PLACE A ROAD NAME PLAQUE ABOVE THE M4-9 SIGN AS SPECIFIED IN THE CONTRACT.

MATCH POINT

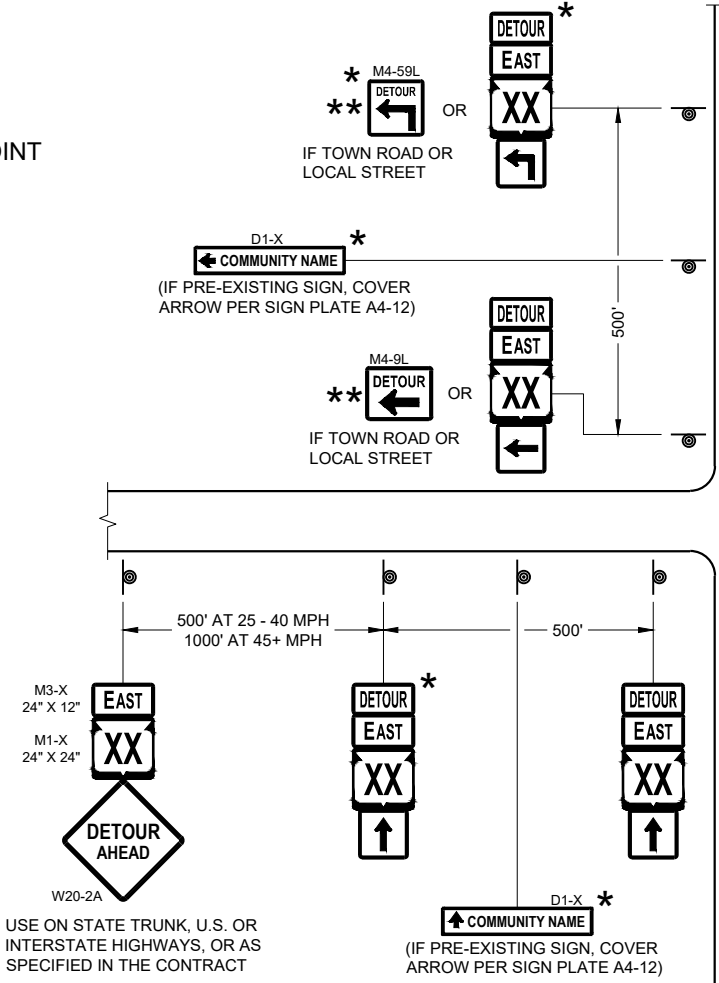

**DETAIL F
DETOUR SIGNING**

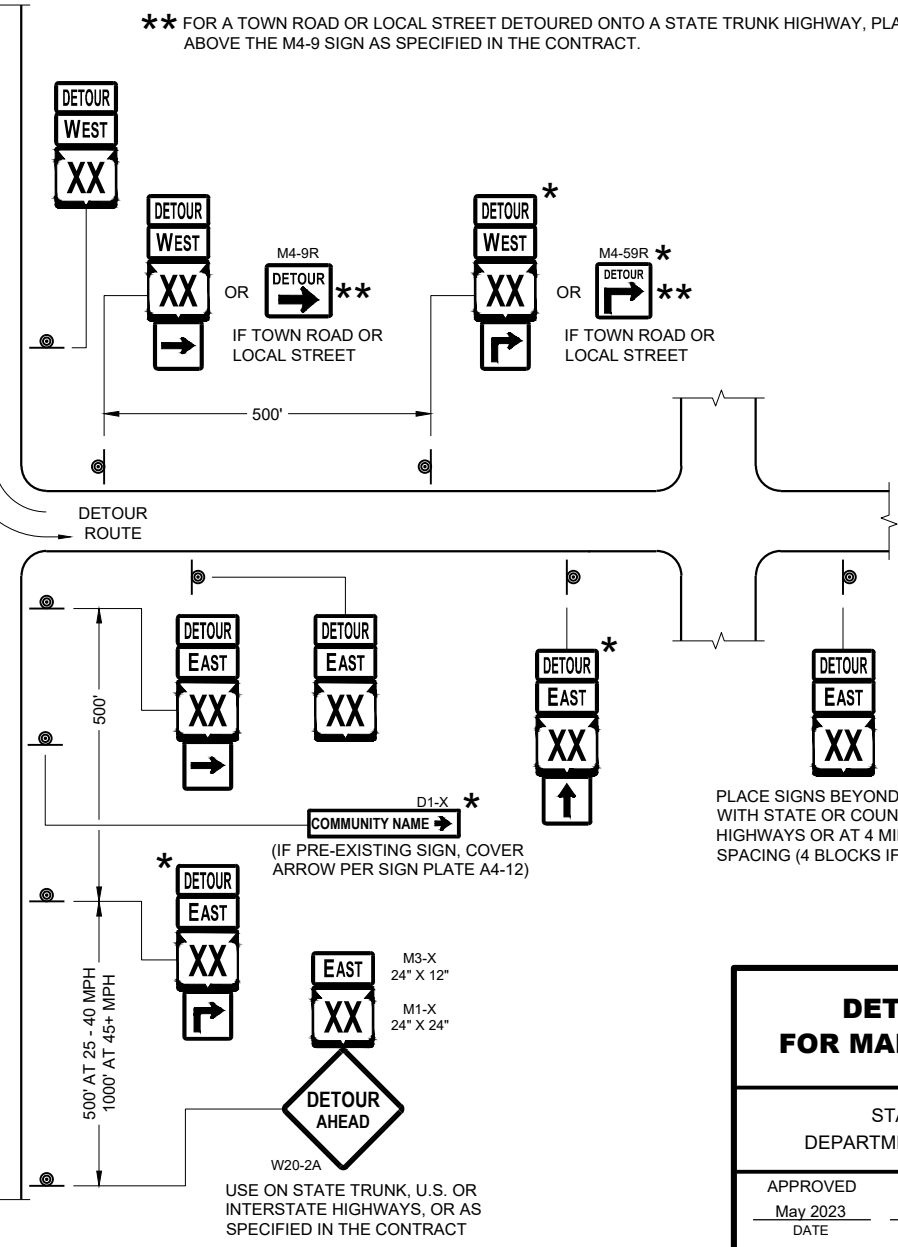

PLACE SIGNS BEYOND INTERSECTIONS WITH STATE OR COUNTY TRUNK HIGHWAYS OR AT 4 MILE MAXIMUM SPACING (4 BLOCKS IF URBAN AREA)

SEE SPECIFIC PROJECT DETOUR SIGNING DETAIL SHEETS AND DETAIL A OR B ON SDD SHEET 15C02 - SHEET "a"

DETOUR SIGNING FOR MAINLINE CLOSURES	
STATE OF WISCONSIN DEPARTMENT OF TRANSPORTATION	
APPROVED May 2023 DATE	/S/ Andrew Heidtke WORK ZONE ENGINEER
<small>FHWA</small>	

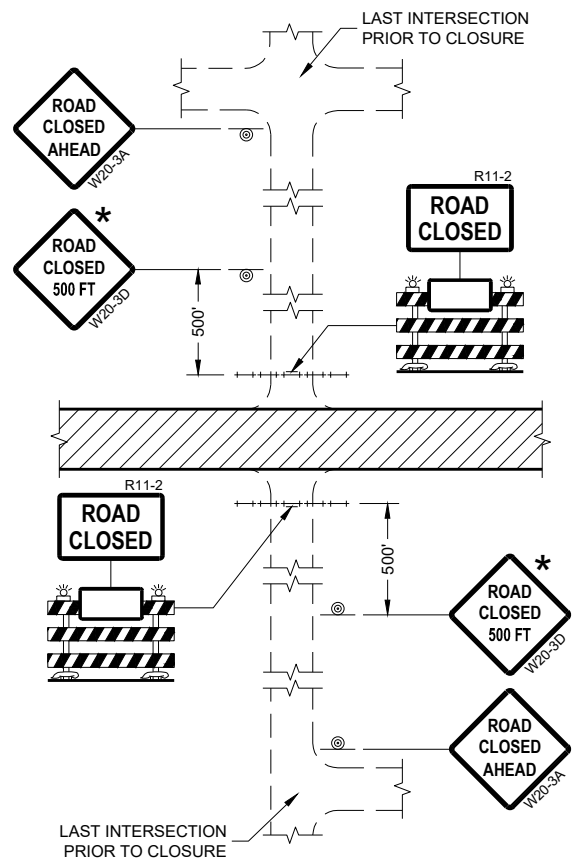

DETAIL 1
(NO ACCESS TO PROJECT)

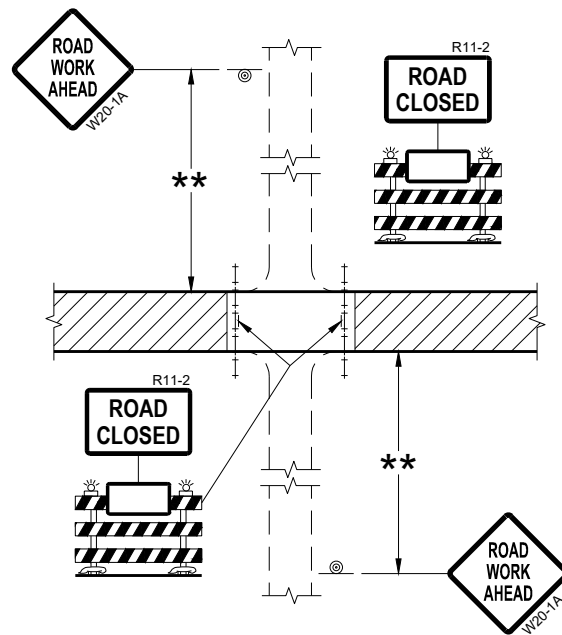

DETAIL 2
(PUBLIC CROSS-TRAFFIC MAINTAINED.
NO ACCESS TO PROJECT)

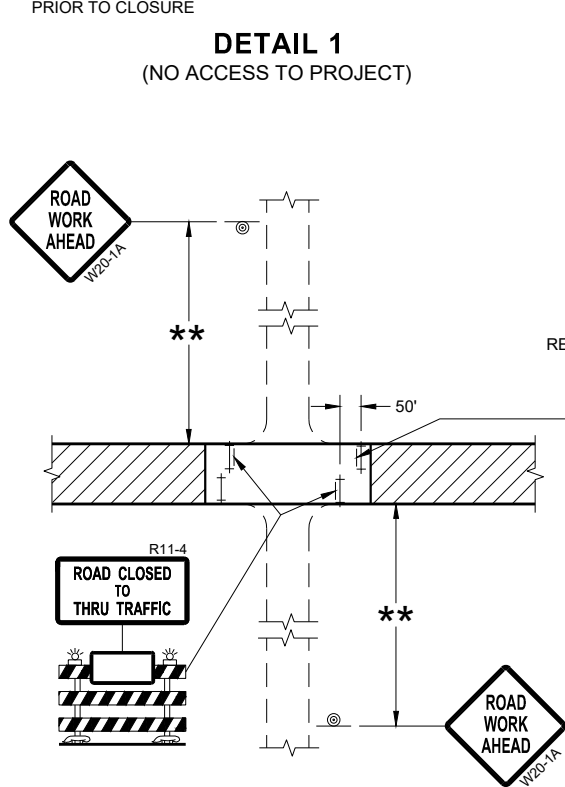

DETAIL 3
(PUBLIC CROSS-TRAFFIC MAINTAINED.
CONTRACTOR, LOCAL BUSINESS AND
RESIDENT ACCESS TO PROJECT)

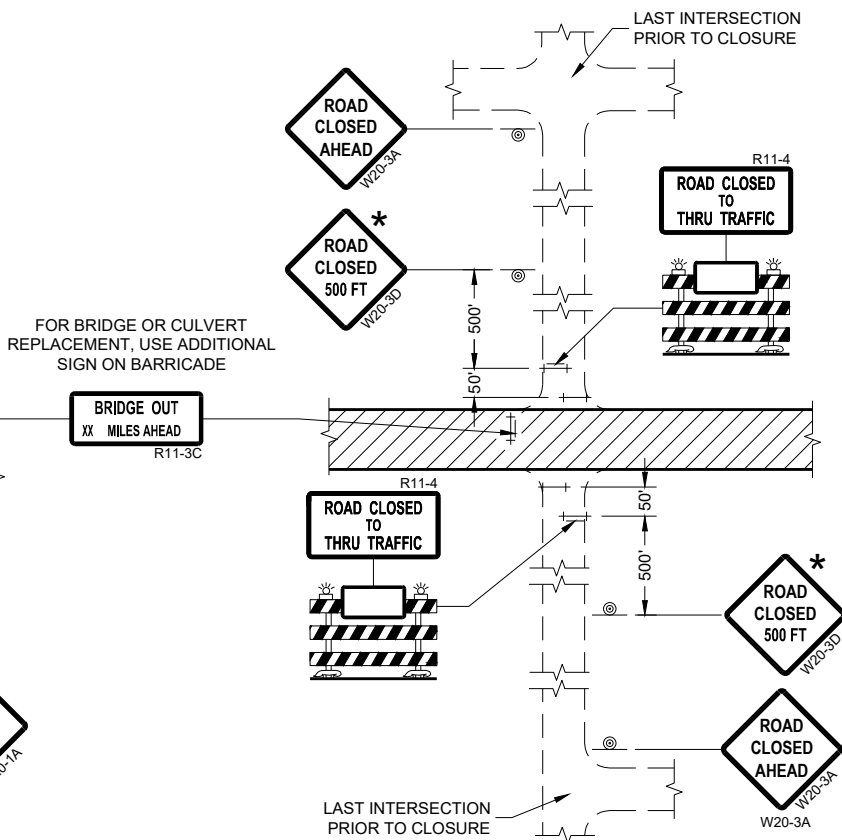

DETAIL 4
(CONTRACTOR, LOCAL BUSINESS AND
RESIDENT ACCESS TO PROJECT)

GENERAL NOTES

THE EXACT NUMBER, LOCATION, AND SPACING OF ALL SIGNS AND BARRICADES SHALL BE ADJUSTED TO FIT FIELD CONDITIONS AS APPROVED BY THE ENGINEER.

ANY SIGNS TEMPORARY OR EXISTING, WHICH CONFLICT WITH TRAFFIC CONTROL "IN USE" SHALL BE REMOVED OR COVERED AS NEEDED AND AS APPROVED BY THE ENGINEER.

THE SPACING BETWEEN TRAFFIC CONTROL SIGNS SHOULD BE ADJUSTED TO NOT CONFLICT WITH AND SHOULD PROVIDE A DESIRABLE MINIMUM OF 200 FEET CLEARANCE (500 FEET DESIRABLE) TO EXISTING SIGNS THAT WILL REMAIN IN PLACE.

IF A "STOP" SIGN MUST BE REMOVED FOR A WORK OPERATION, A TEMPORARY "STOP" SIGN SHALL BE PLACED PRIOR TO THE SIGN REMOVAL, OR A FLAGGER SHALL BE PROVIDED UNTIL THE SIGN IS REESTABLISHED.

BARRICADES THAT MUST BE MOVED FOR A WORK OPERATION SHALL BE IMMEDIATELY REESTABLISHED UPON COMPLETION OF THE OPERATION OR FOR CONTINUING OPERATIONS, AT THE END OF EACH WORKING DAY.

SIGNS THAT WILL BE IN PLACE LESS THAN SEVEN CONTINUOUS DAYS AND NIGHTS MAY BE MOUNTED ON PORTABLE SUPPORTS.

ALL TYPE III BARRICADES SHALL HAVE RAILS REFLECTORIZED ON BOTH FACES. STRIPES SHALL BE PROPERLY SLOPED DOWN TOWARD THE TRAFFIC SIDE OR AS SHOWN IN THE ROAD CLOSURE BARRICADE DETAIL "D" FOR FULL ROAD CLOSURES.

TYPE "A" LOW-INTENSITY FLASHING WARNING LIGHTS SHALL BE VISIBLE ON BOTH SIDES OF THE BARRICADE.

THE R11-2, R11-3, AND R11-4 SIGNS PLACED ON BARRICADES SHALL COVER NO MORE THAN THE TOP RAIL. THE SIGNS SHALL NOT COVER ANY PORTION OF THE MIDDLE OR BOTTOM RAILS.

ALL SIGNS SHALL BE 48" X 48" UNLESS OTHERWISE NOTED BELOW:
R11-2 SHALL BE 48" X 30".
R11-4 AND R11-3 SHALL BE 60" X 30".

- * OMIT THE "ROAD CLOSED 500 FT." SIGN IF THE LAST INTERSECTION IS 500 FEET OR LESS FROM THE WORK ZONE.
- ** 500' MAX. OR AT LAST INTERSECTION, WHICHEVER IS CLOSEST.

LEGEND

- ⊙ SIGN ON PERMANENT SUPPORT
- ⊥ TYPE III BARRICADE
- ⊥ TYPE III BARRICADE WITH ATTACHED SIGN
- ⚡ TYPE "A" WARNING LIGHT (FLASHING)
- ▨ WORK AREA

**BARRICADES AND SIGNS
FOR
SIDEROAD CLOSURES**

STATE OF WISCONSIN
DEPARTMENT OF TRANSPORTATION

APPROVED
July 2018 /S/ Andrew Heidtke
DATE WORK ZONE ENGINEER

GENERAL NOTES

THE EXACT NUMBER, LOCATION, AND SPACING OF ALL SIGNS AND DEVICES SHALL BE ADJUSTED TO FIT FIELD CONDITIONS.

THE SPACING BETWEEN TRAFFIC CONTROL SIGNS SHOULD BE ADJUSTED TO NOT CONFLICT WITH AND SHOULD PROVIDE A MINIMUM OF 200 FEET (500 FEET DESIRABLE) CLEARANCE TO EXISTING SIGNS THAT WILL REMAIN IN PLACE.



ALL SIGNS ARE 48" X 48" UNLESS OTHERWISE NOTED. IF NECESSARY DUE TO SPACE CONSTRAINTS, 36"X36" SIGNS MAY BE USED INSTEAD OF 48" X 48" SIGNS.

SIGNS THAT WILL BE IN PLACE LESS THAN SEVEN CONTINUOUS DAYS AND NIGHTS MAY BE MOUNTED ON PORTABLE SUPPORTS.

IF A "STOP" SIGN MUST BE REMOVED FOR A WORK OPERATION, A TEMPORARY "STOP" SIGN SHALL BE PLACED PRIOR TO THE SIGN REMOVAL, OR A FLAGGER SHALL BE PROVIDED UNTIL THE SIGN IS REESTABLISHED.

* THE THIRD W20-1 SIGN IS REQUIRED ONLY IF THERE IS AN INTERSECTION BETWEEN THE "ROAD WORK 500 FEET" SIGN AND THE WORK ZONE. ADJUST THE PLACEMENT OF THIS SIGN BASED ON INTERSECTION LOCATION AND OTHER FIELD CONDITIONS.

LEGEND

-  SIGN ON PERMANENT SUPPORT
-  DIRECTION OF TRAFFIC
-  WORK AREA

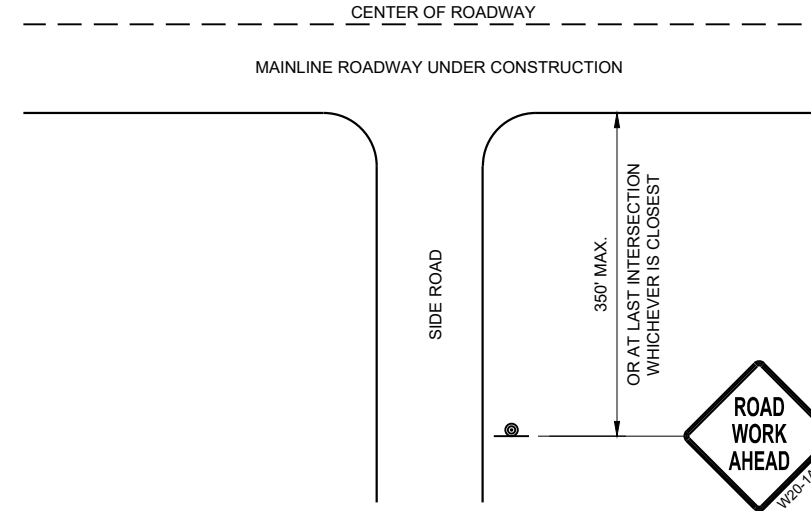

**TYPICAL SIDE ROAD APPROACH
WARNING SIGN DETAIL**

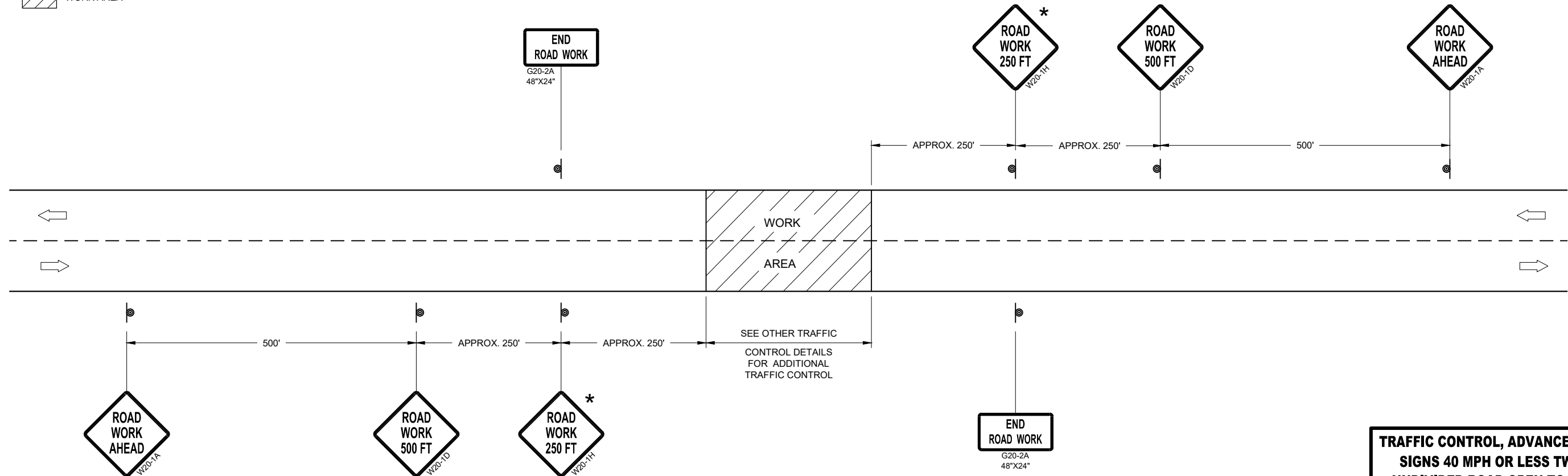

TRAFFIC CONTROL, ADVANCE WARNING SIGNS 40MPH OR LESS

**TRAFFIC CONTROL, ADVANCE WARNING
SIGNS 40 MPH OR LESS TWO-WAY
UNDIVIDED ROAD OPEN TO TRAFFIC**

STATE OF WISCONSIN
DEPARTMENT OF TRANSPORTATION

APPROVED
July 2018 /S/ Andrew Heidtke
DATE WORK ZONE ENGINEER

FHWA

GENERAL NOTES

DETAILS OF INSTALLATION, MATERIALS AND WORKMANSHIP NOT SHOWN ON THIS DRAWING SHALL CONFORM TO THE PERTINENT REQUIREMENTS OF THE STANDARD SPECIFICATIONS AND APPLICABLE SPECIAL PROVISIONS.

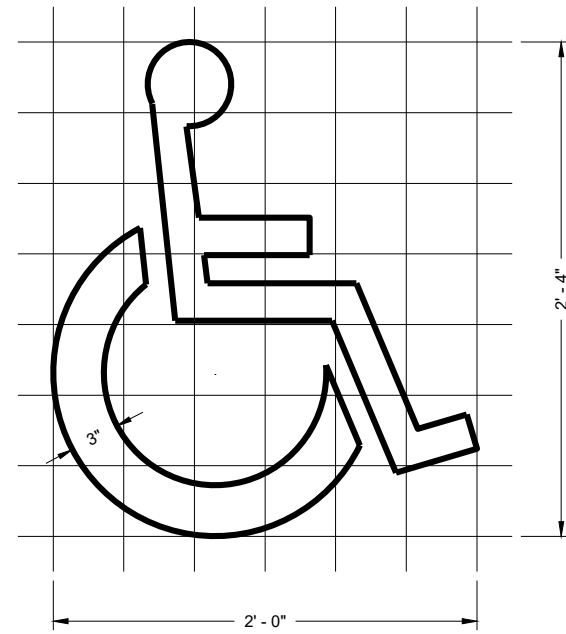

HANDICAP SYMBOL

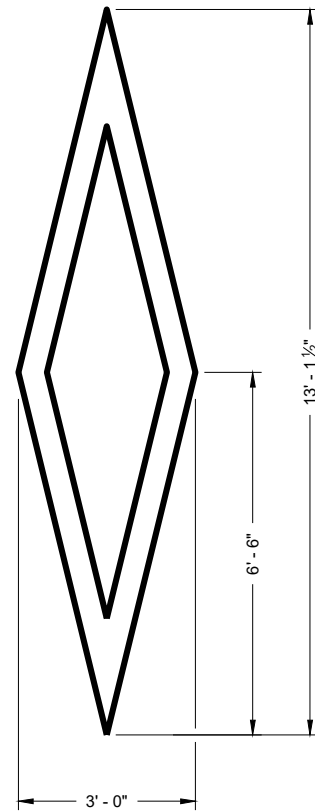

PREFERENTIAL LANE SYMBOL

PAVEMENT MARKING SYMBOLS

STATE OF WISCONSIN
DEPARTMENT OF TRANSPORTATION

APPROVED
November 2019 /S/ Matthew Rauch
DATE STATE SIGNING AND MARKING
ENGINEER

FHWA

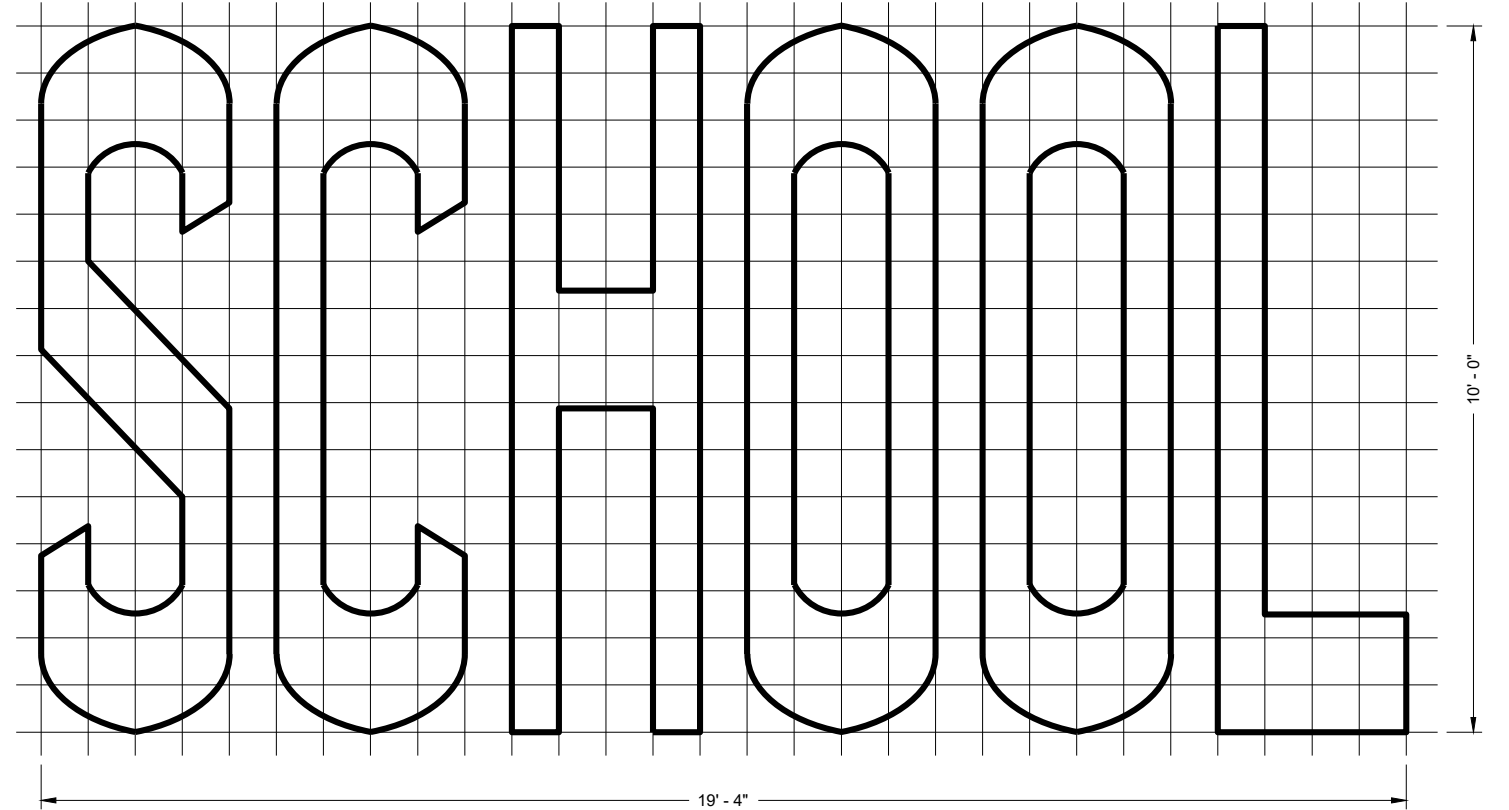
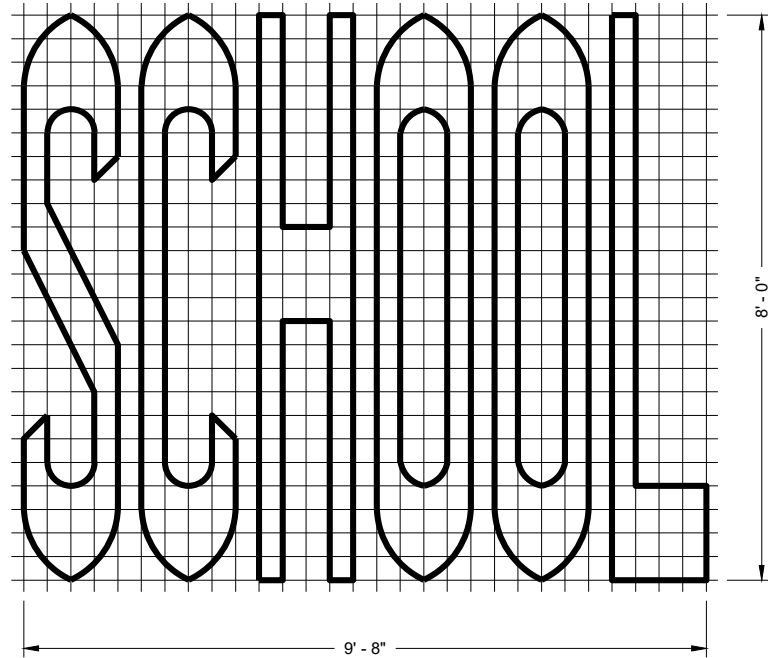
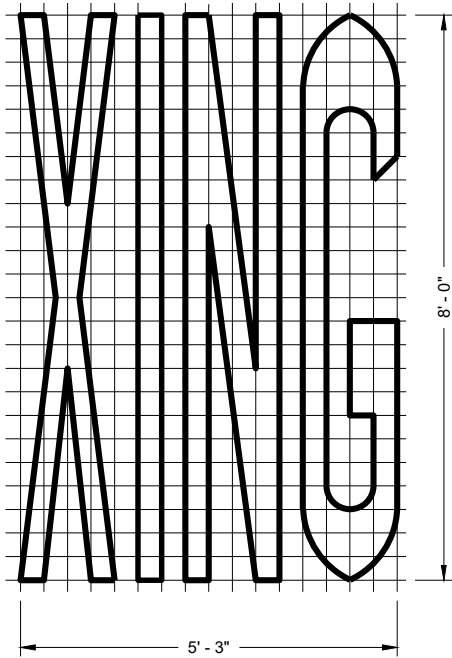
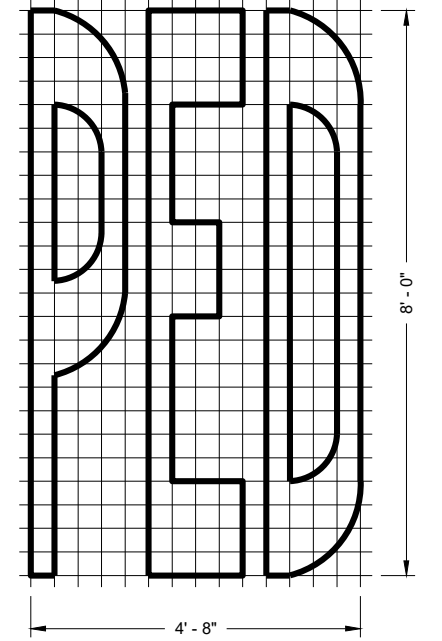
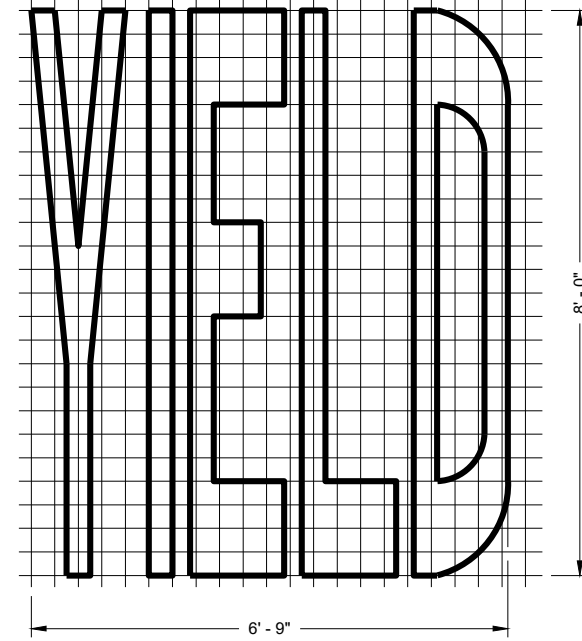
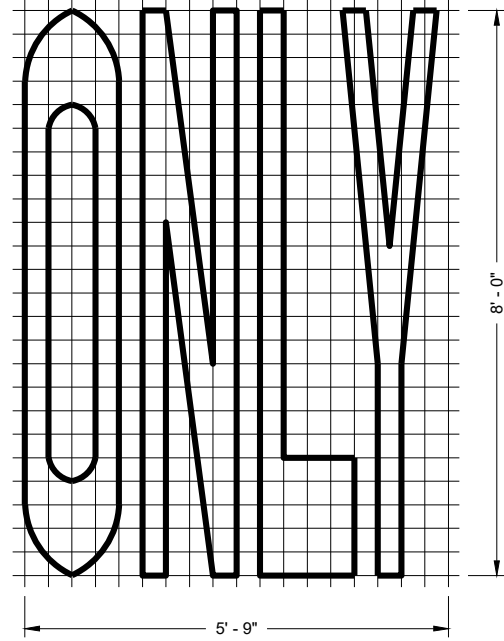
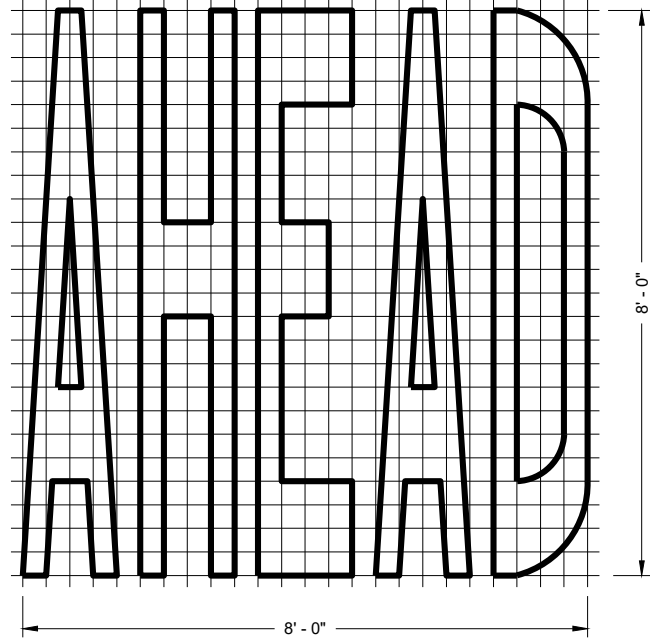
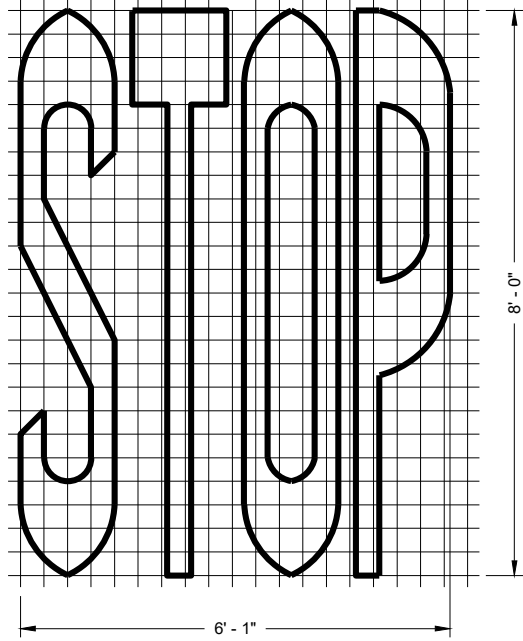

SINGLE LANE

TWO - LANE

GENERAL NOTES

DETAILS OF INSTALLATION, MATERIALS AND WORKMANSHIP NOT SHOWN ON THIS DRAWING SHALL CONFORM TO THE PERTINENT REQUIREMENTS OF THE STANDARD SPECIFICATIONS AND APPLICABLE SPECIAL PROVISIONS.

PAVEMENT MARKING WORDS

STATE OF WISCONSIN
DEPARTMENT OF TRANSPORTATION

APPROVED
November 2019 /S/ Matthew Rauch
DATE STATE SIGNING AND MARKING
ENGINEER

FHWA

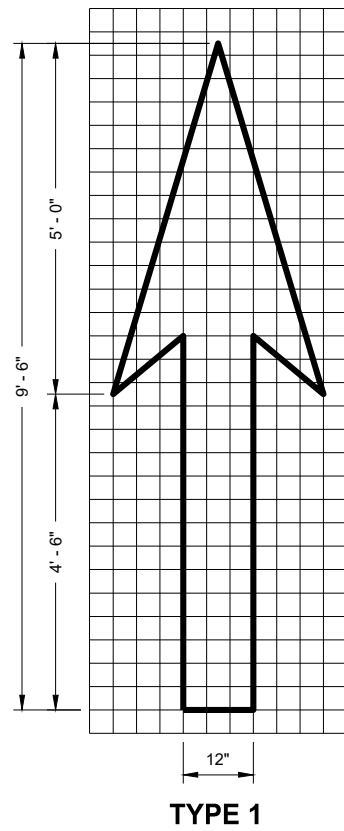

TYPE 1

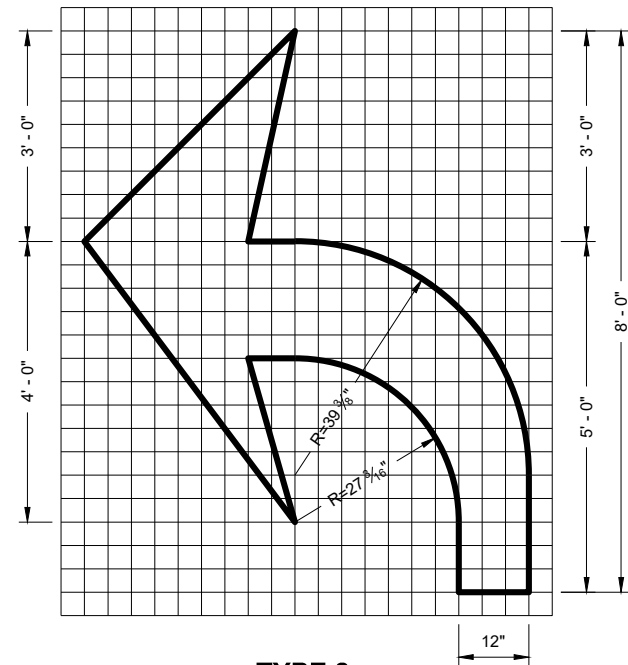

TYPE 2

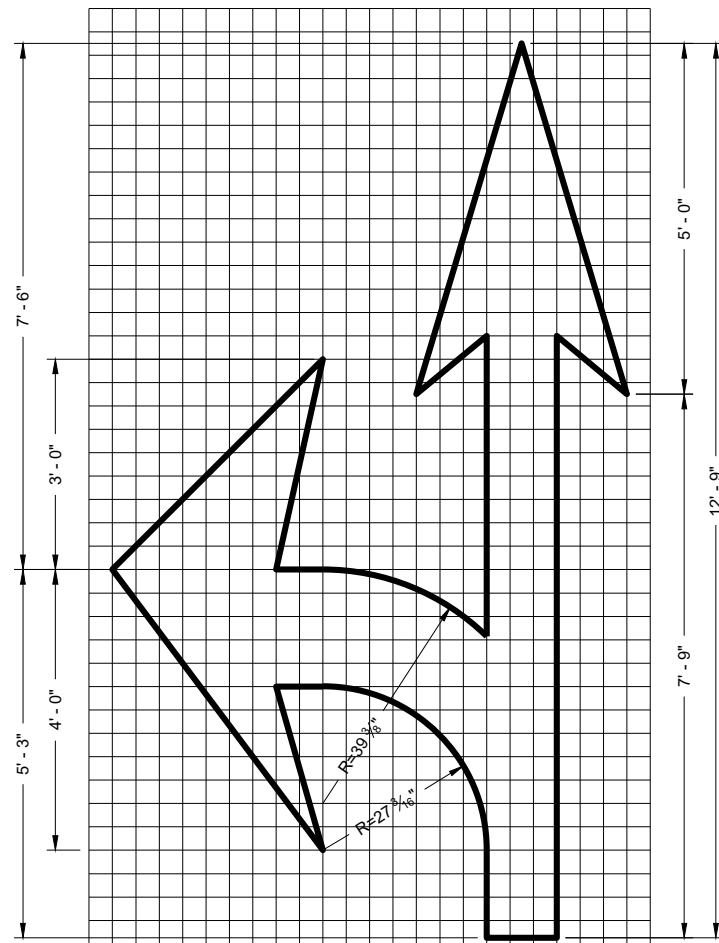

TYPE 3

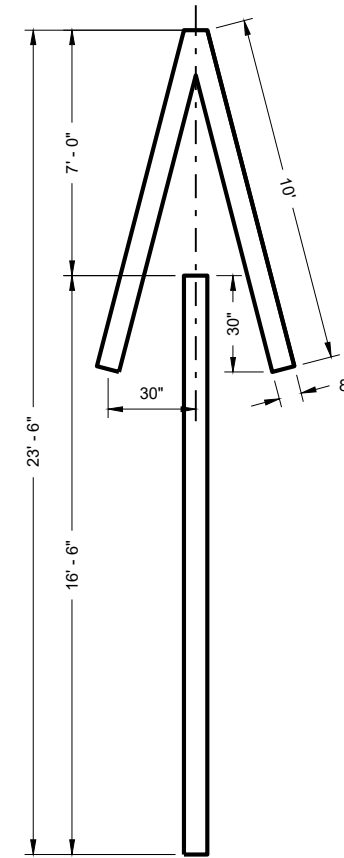

TYPE 4

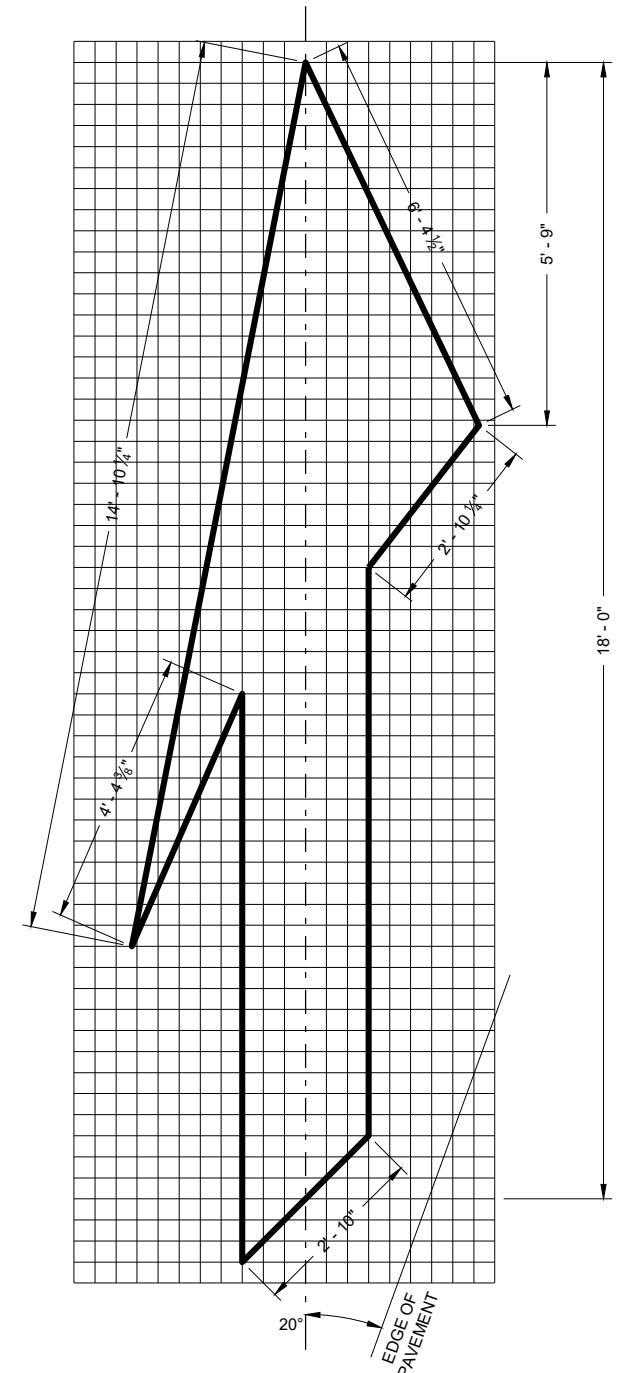

TYPE 5 LANE DROP ARROW

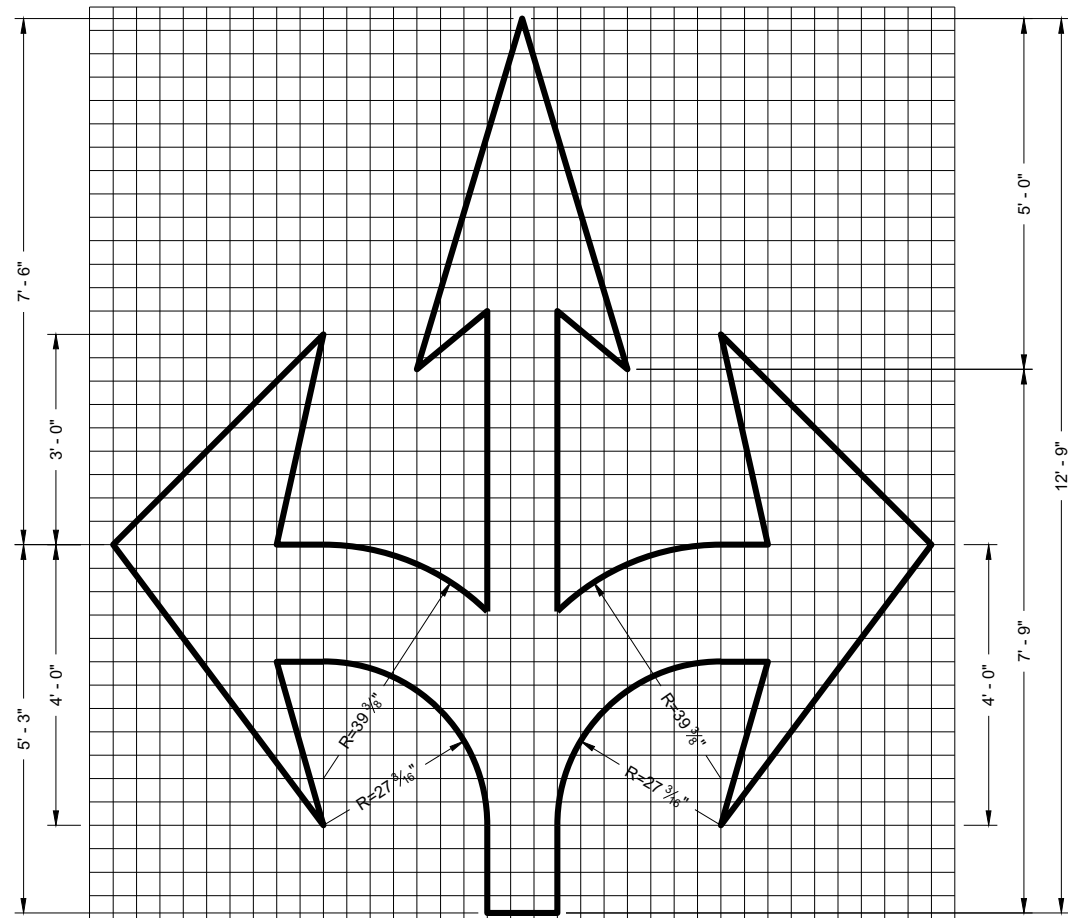

TYPE 6

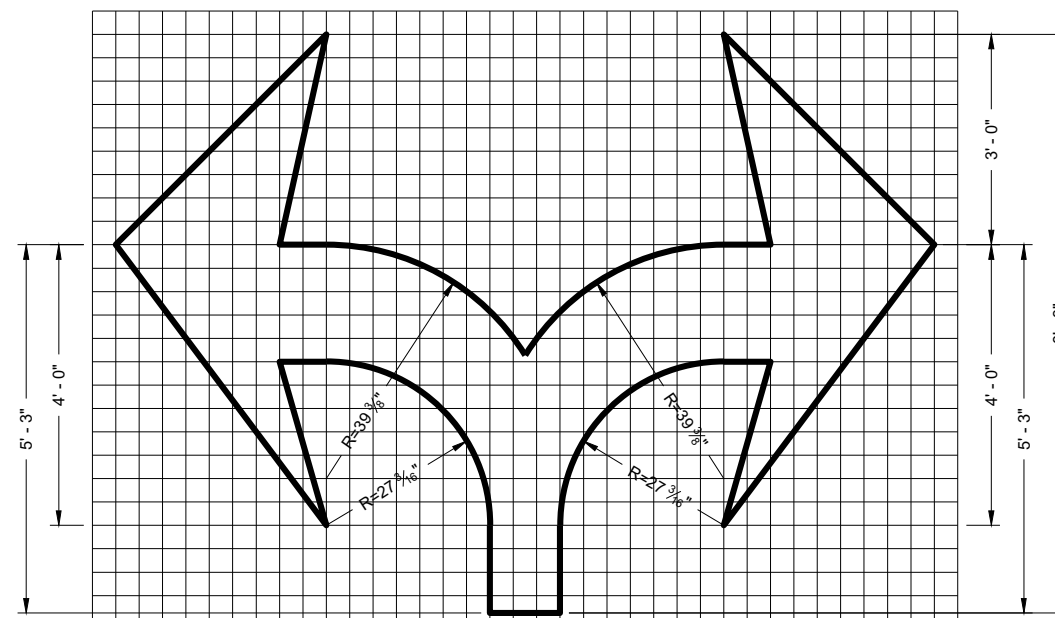

TYPE 7

GENERAL NOTES

DETAILS OF INSTALLATION, MATERIALS AND WORKMANSHIP NOT SHOWN ON THIS DRAWING SHALL CONFORM TO THE PERTINENT REQUIREMENTS OF THE STANDARD SPECIFICATIONS AND APPLICABLE SPECIAL PROVISIONS.

PAVEMENT MARKING ARROWS

STATE OF WISCONSIN
DEPARTMENT OF TRANSPORTATION

APPROVED	/s/ Matthew Rauch
November 2019	STATE SIGNING AND MARKING ENGINEER
DATE	

FHWA

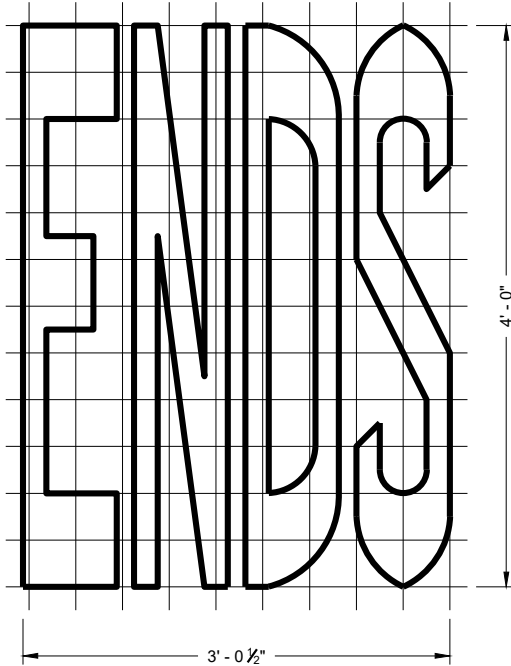
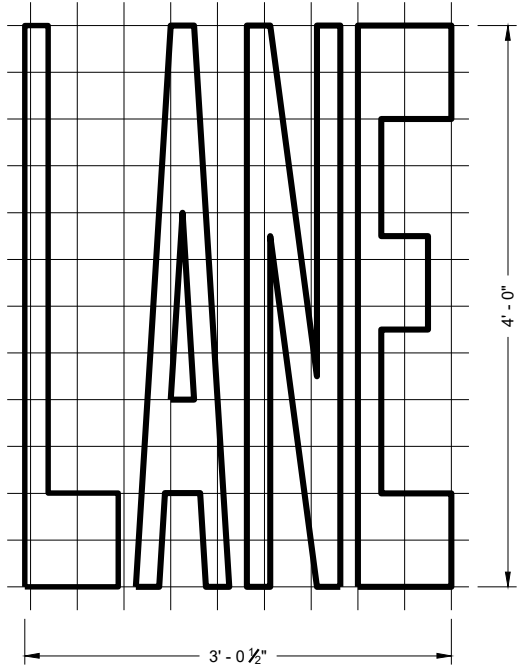
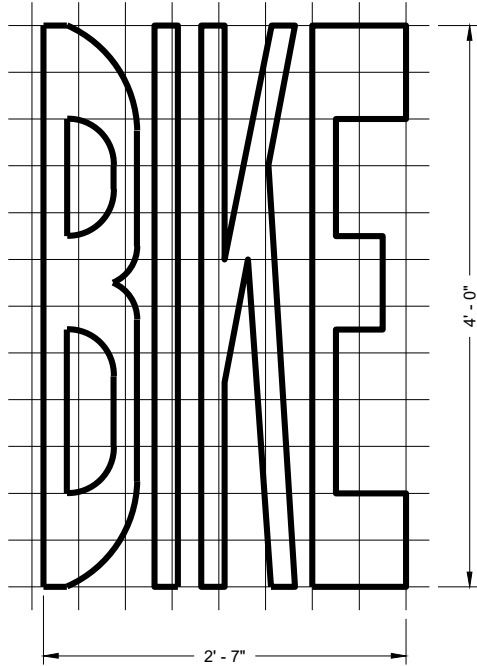

BIKE LANE WORDS

GENERAL NOTES

DETAILS OF INSTALLATION, MATERIALS AND WORKMANSHIP NOT SHOWN ON THIS DRAWING SHALL CONFORM TO THE PERTINENT REQUIREMENTS OF THE STANDARD SPECIFICATIONS AND APPLICABLE SPECIAL PROVISIONS.

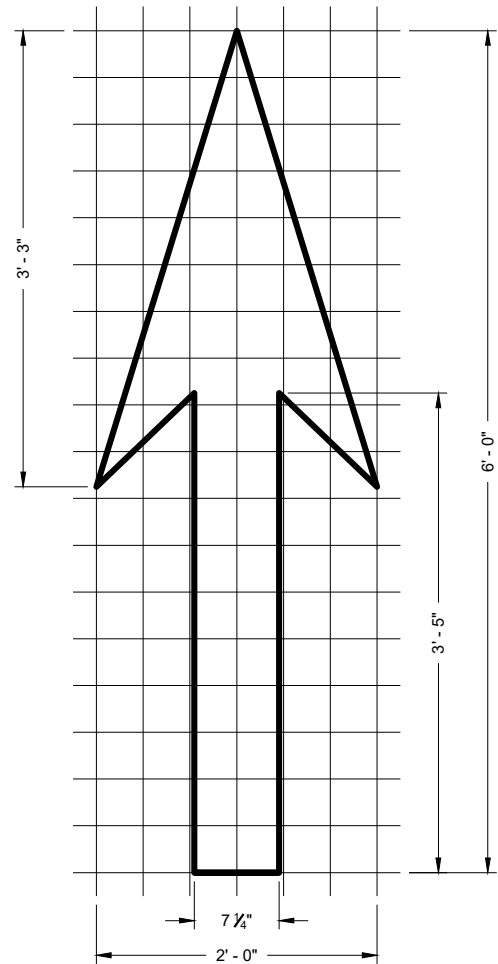
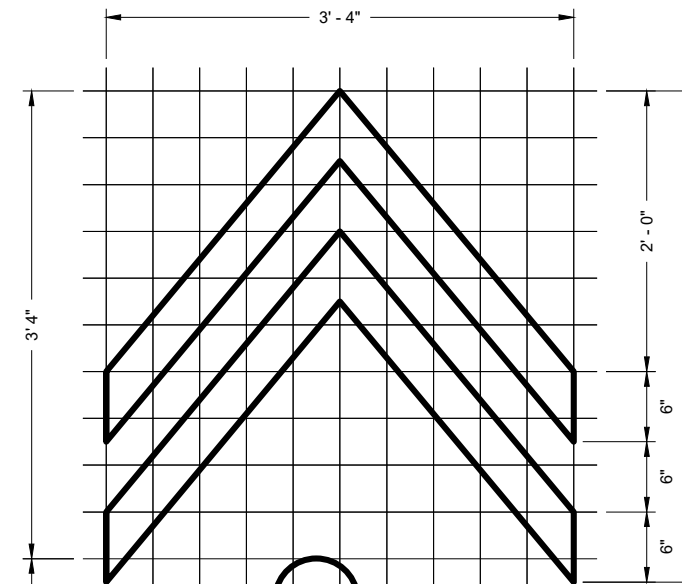

BIKE LANE ARROW

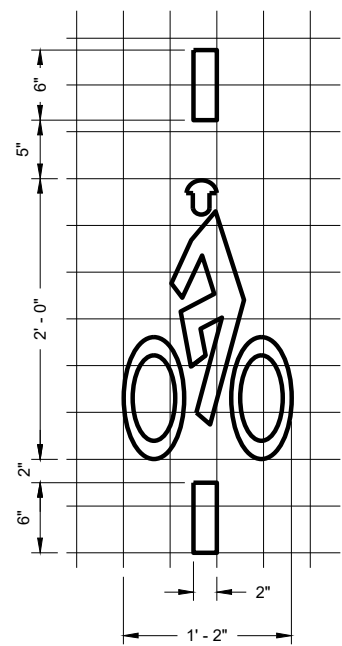

BIKE DETECTOR PAVEMENT MARKING

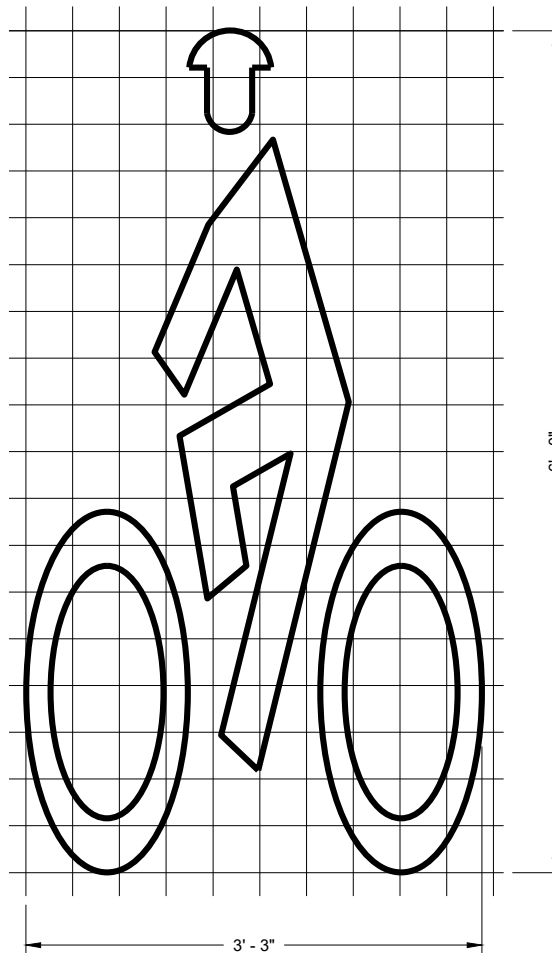

BIKE LANE SYMBOL

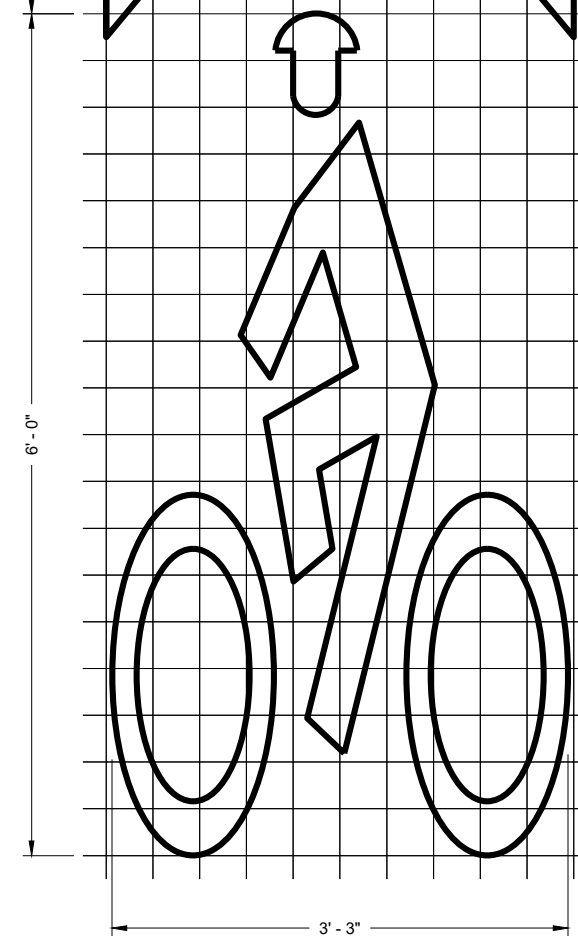

BIKE LANE SYMBOL FOR SHARED LANE

6

6

PAVEMENT MARKING FOR BIKE LANES

STATE OF WISCONSIN
DEPARTMENT OF TRANSPORTATION

APPROVED
November 2019 /S/ Matthew Rauch
DATE STATE SIGNING AND MARKING
ENGINEER



FHWA

GENERAL NOTES

DETAILS OF CONSTRUCTION NOT SHOWN ON THIS DRAWING SHALL CONFORM TO STANDARD SPECIFICATIONS AND SPECIAL PROVISIONS.

- ① LOCATE THE NO PASSING ZONE W14-3 SIGN WITHIN 50 FEET OF THE "T" MARKING
- ② MEASURE FROM EDGE OF MARKING TO JOINT LINE. THIS DOES NOT INCLUDE SPACE NEEDED FOR GROOVING OPERATIONS.

LEGEND

-  "T" MARKING
-  SIGN ON PERMANENT SUPPORT
-  DIRECTION OF TRAFFIC

* CONFIRM MARKING LINE WIDTH WITH THE MISCELLANEOUS QUANTITIES

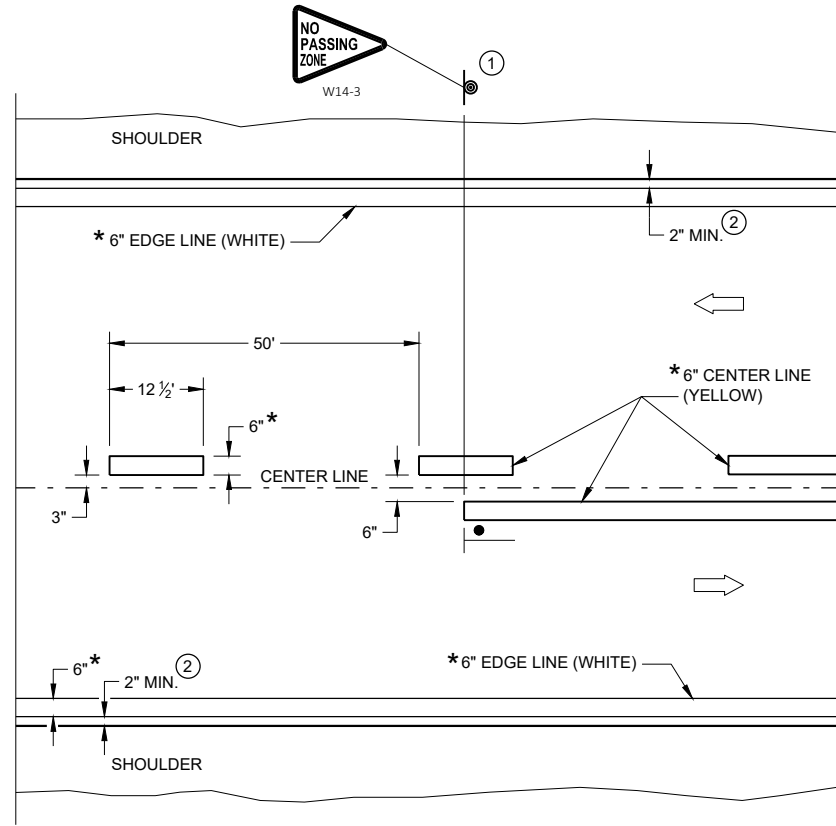

TWO WAY TRAFFIC

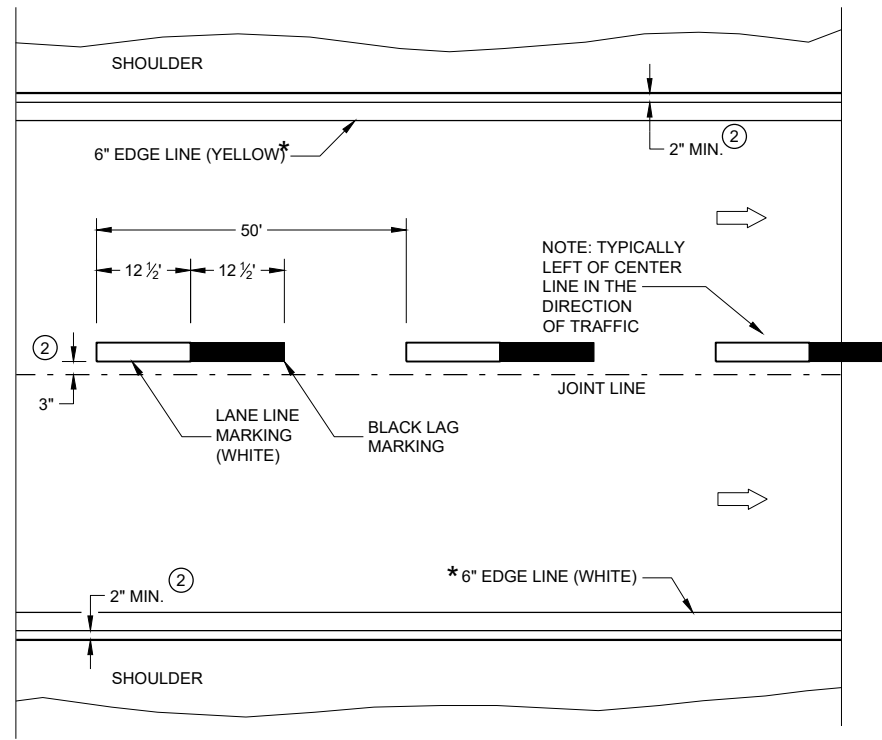

ONE WAY TRAFFIC

PERMANENT PAVEMENT MARKING

6

6

SDD 15C08-23a

SDD 15C08-23a

PERMANENT LONGITUDINAL PAVEMENT MARKINGS

STATE OF WISCONSIN
DEPARTMENT OF TRANSPORTATION

APPROVED
May 2023 /S/ Jeannie Silver
DATE STATEWIDE SIGNING AND MARKING ENGINEER

FHWA

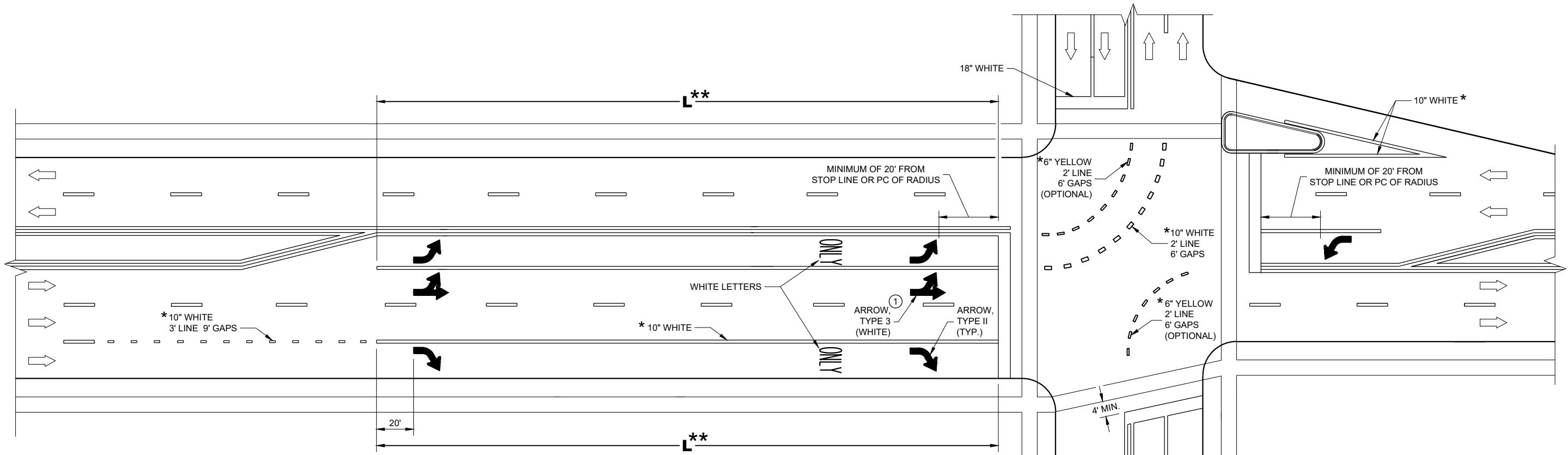

TURN LANE OPTIONS

LENGTH OF TURN BAY (**L**) OF 0 - 47' DOES NOT REQUIRE PAVEMENT MARKING ARROWS OR WORDS

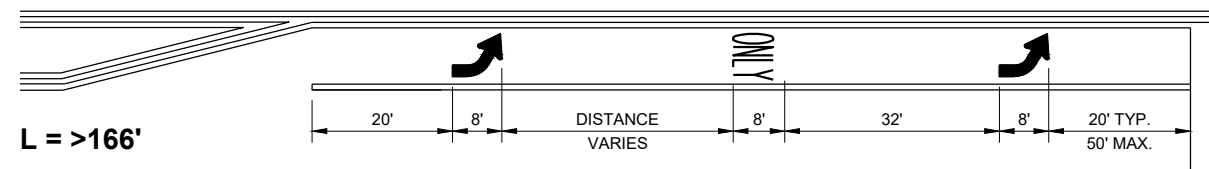
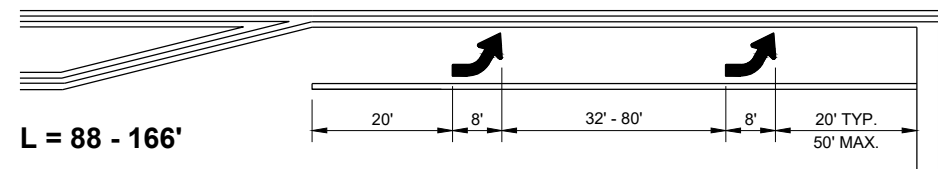
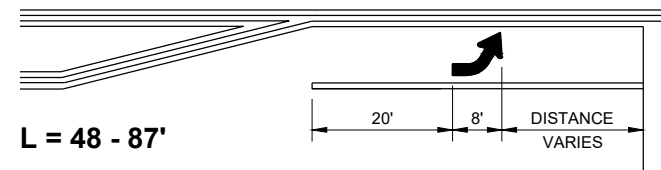

** (SEE TURN LANE OPTIONS FOR PLACEMENT OF PAVEMENT MARKING ARROWS AND WORDS)

GENERAL NOTES

① QUANTITY AND LOCATION OF TYPE 3 ARROWS ARE THE SAME AS THE TYPE II ARROWS IN THE ADJACENT TURN LANE. FOR TURN LANES WITH A PHYSICAL SEPARATION IN THE SAME DIRECTION OF TRAVEL, THE ARROWS AND "ONLY" MARKING MAY BE ELIMINATED.

➡ DIRECTION OF TRAFFIC

L = LENGTH OF TURN BAY

* CONFIRM MARKING LINE WIDTH WITH THE MISCELLANEOUS QUANTITIES

PAVEMENT MARKING (TURN LANES)

STATE OF WISCONSIN
DEPARTMENT OF TRANSPORTATION

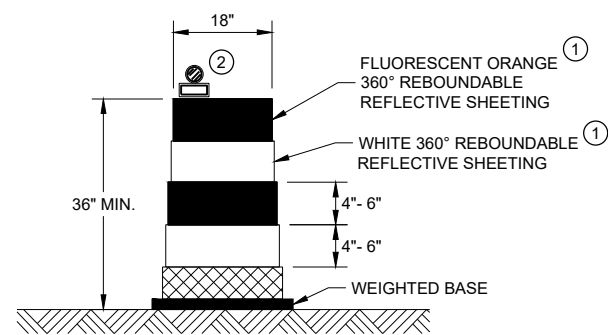

DRUM

BALLAST WIDTHS
RANGE FROM 24"-36"

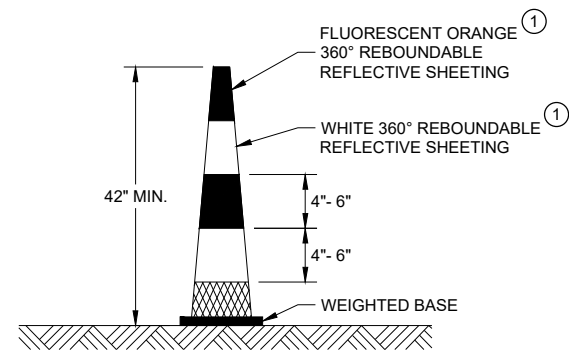

42" CONE

DO NOT USE IN TAPERS
½ SPACING OF DRUMS
BALLAST WIDTHS
RANGE FROM 14"-20"

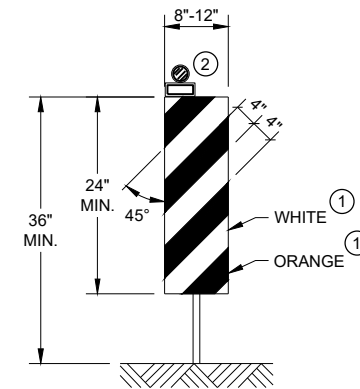

VERTICAL PANEL

THE STRIPES SHALL SLOPE DOWNWARD TO
THE TRAFFIC SIDE FOR CHANNELIZATION.

GENERAL NOTES

- ① REFLECTIVE SHEETING SHALL FOLLOW THE REQUIREMENTS IN THE APPROVED PRODUCTS LISTING FOR SIGN SHEETING.
- ② LOCATION OF WARNING LIGHTS WHEN SHOWN ON THE PLAN.

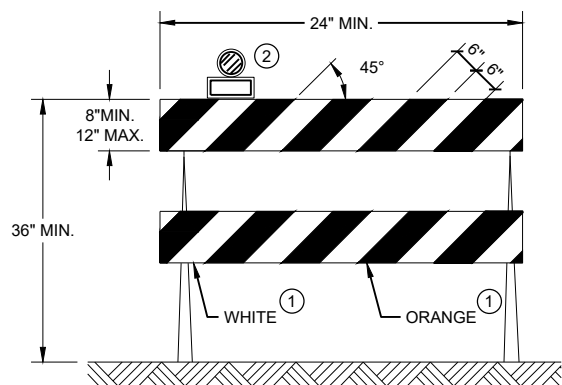

TYPE II BARRICADE

FOR RAILS LESS THAN 36" LONG, 4" WIDE STRIPES
MAY BE USED. ALL STRIPES SHALL SLOPE DOWNWARD
TO THE TRAFFIC SIDE FOR CHANNELIZATION.

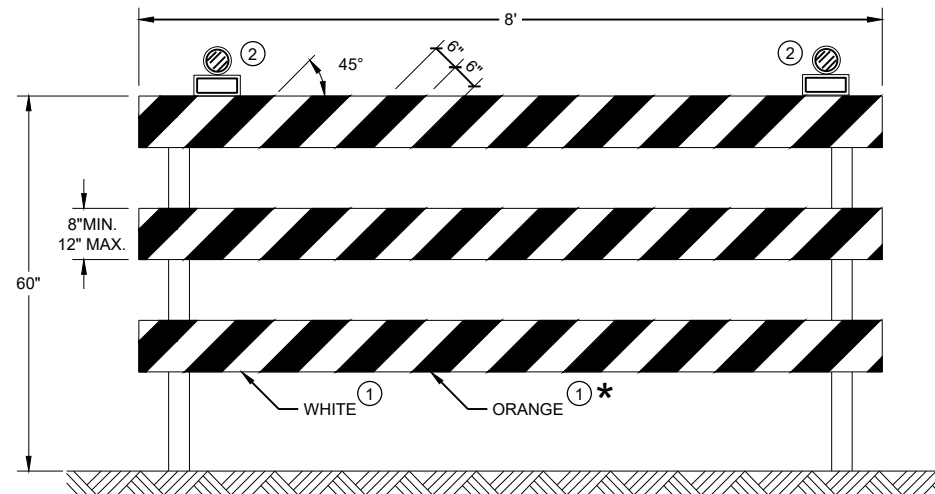

TYPE III BARRICADE

IF SIGN MOUNTED, DO NOT COVER MORE THAN 50% OF THE TOP
TWO RAILS OR 33% OF THE TOTAL AREA OF THE THREE RAILS.

* IF USED FOR A PERMANENT APPLICATION USE RED SHEETING.

**CHANNELIZING DEVICES
DRUMS, CONES, BARRICADES
AND VERTICAL PANELS**

STATE OF WISCONSIN
DEPARTMENT OF TRANSPORTATION

APPROVED
 November 2022 /S/ Andrew Heidtke
 DATE WORK ZONE ENGINEER
 FHWA

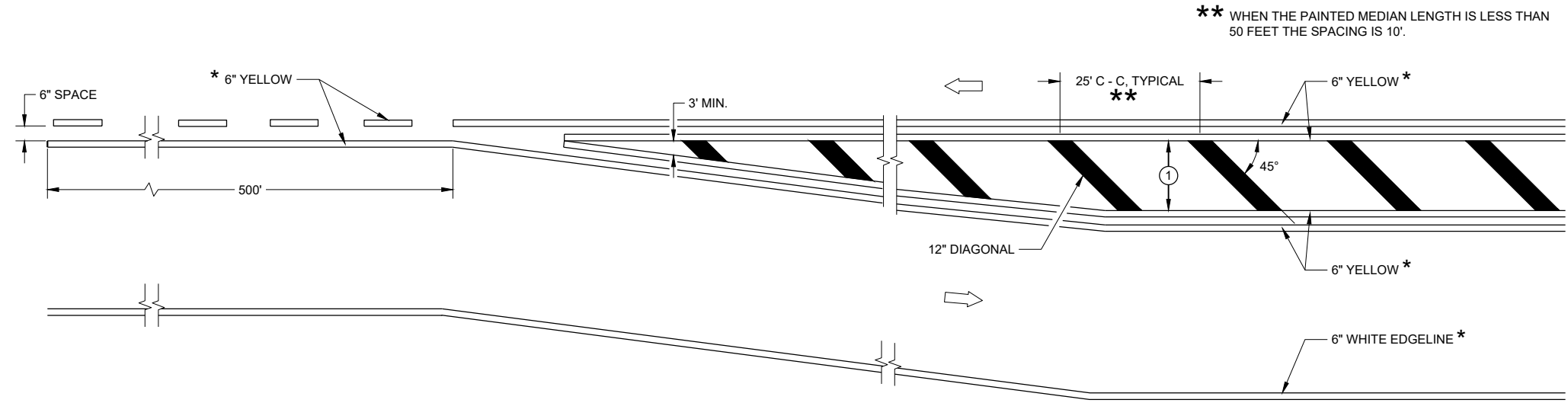

MEDIAN ISLAND DETAIL

** WHEN THE PAINTED MEDIAN LENGTH IS LESS THAN 50 FEET THE SPACING IS 10'.

GENERAL NOTES

① DIAGONALS ARE OPTIONAL WHEN PAINTED ISLAND IS LESS THAN 6 FEET AT THE WIDEST POINT. OMIT DIAGONALS IF WIDTH IS LESS THAN 4 FEET.

➔ DIRECTION OF TRAVEL

* CONFIRM MARKING LINE WIDTH WITH THE MISCELLANEOUS QUANTITIES

SPEED LIMIT	L
<35 MPH	5'
35> MPH	50'

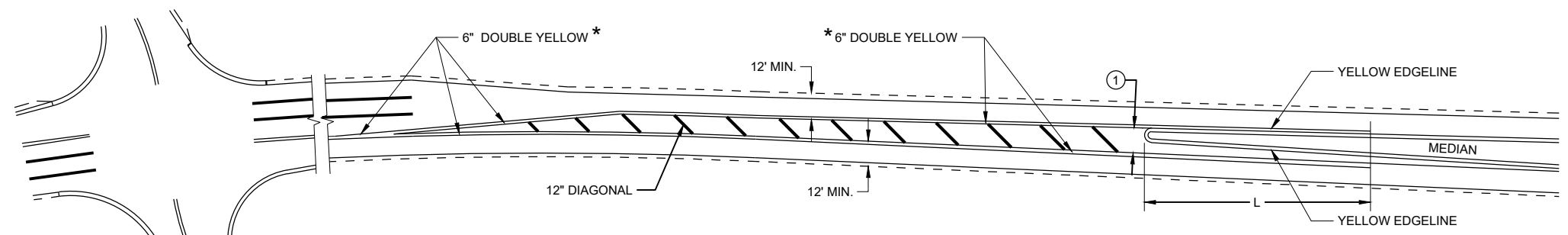

APPROACH MARKINGS FOR OTHER MEDIAN TYPES

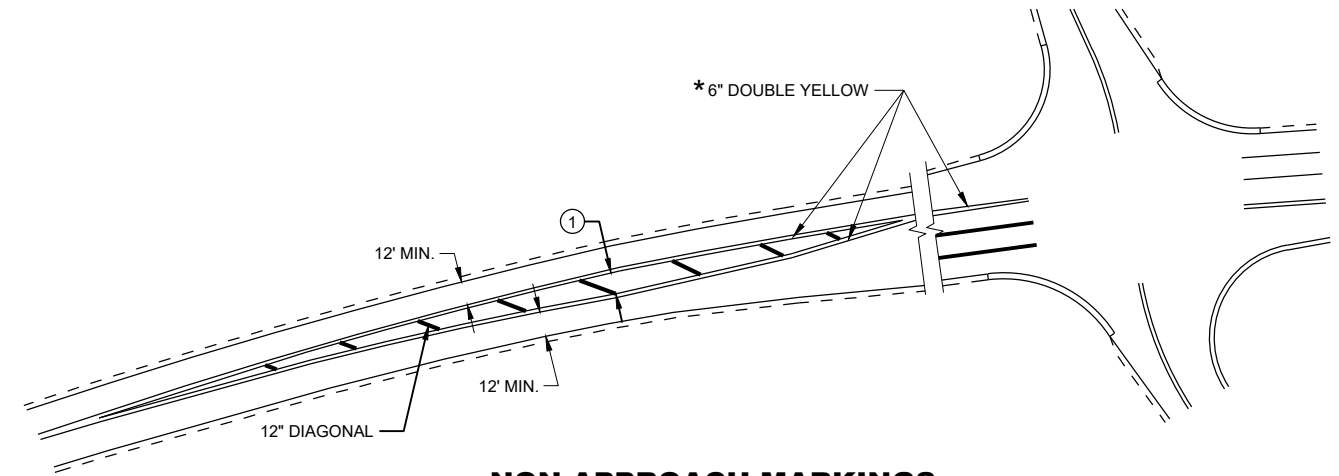

NON-APPROACH MARKINGS

6

6

SDD 15C18-08a

SDD 15C18-08a

MEDIAN ISLAND PAVEMENT MARKINGS	
STATE OF WISCONSIN DEPARTMENT OF TRANSPORTATION	
APPROVED May 2023 DATE	/S/ Jeannie Silver STATE SIGNING AND MARKING ENGINEER
<small>FHWA</small>	

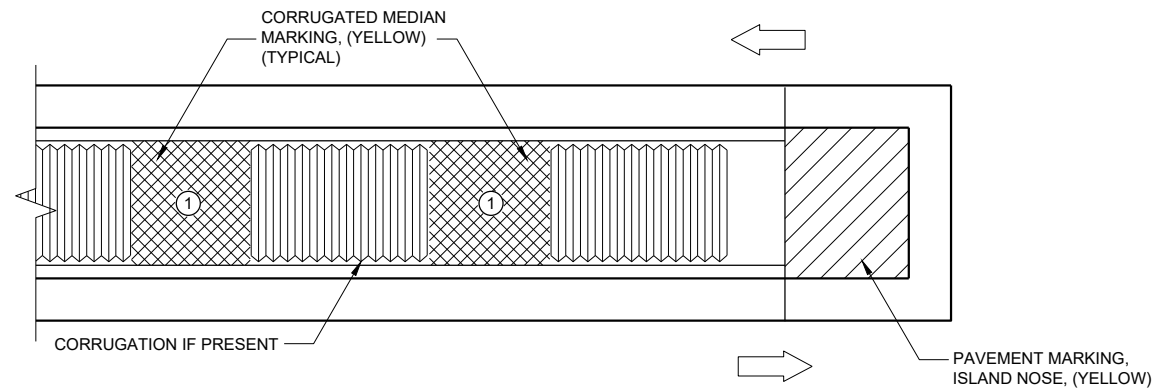

MEDIAN ISLAND WITH SQUARE BLUNT NOSE

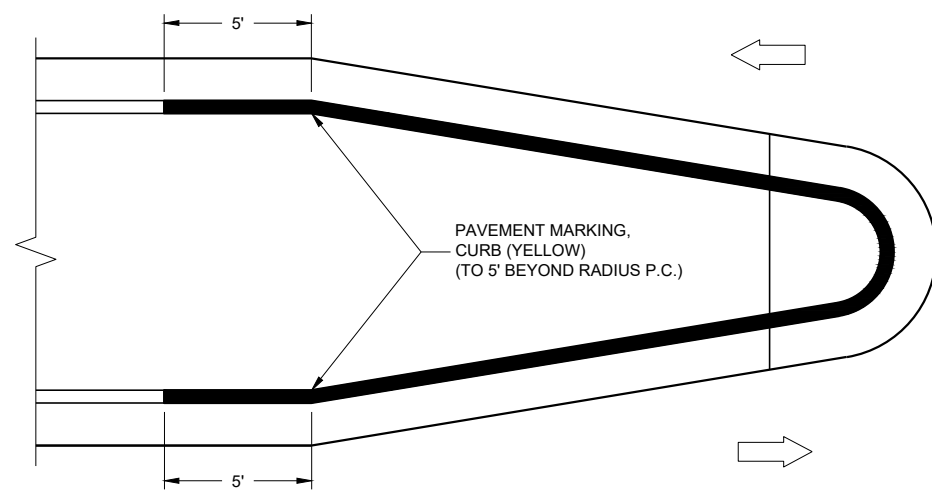

MEDIAN ISLAND WITH ROUND BLUNT NOSE

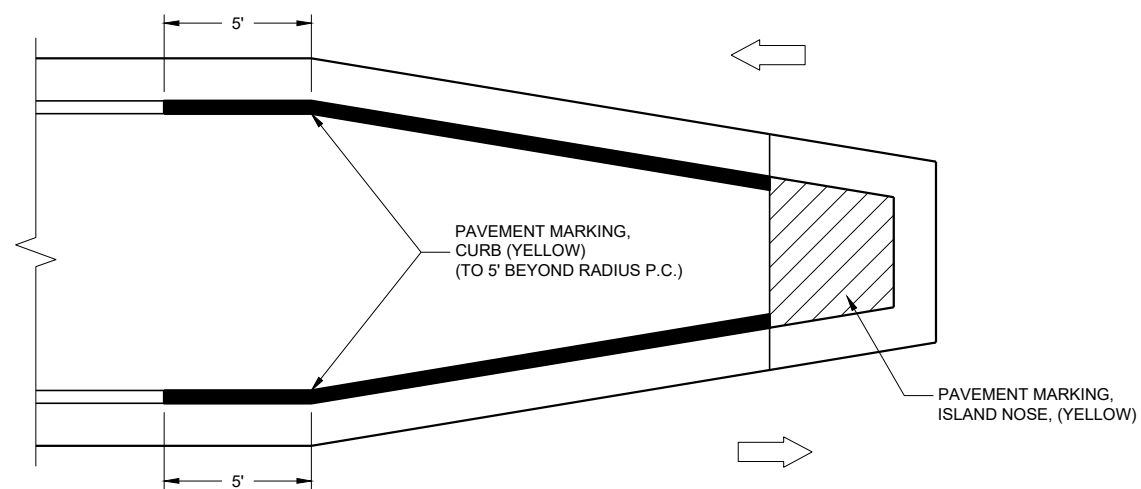





MEDIAN ISLAND WITH SLOPED NOSE

TYPICAL PLACEMENT OF PAVEMENT MARKING ON MEDIAN ISLANDS

GENERAL NOTES

WHEN CONCRETE CORRUGATED MEDIAN IS CONSTRUCTED TO SEPARATE TRAFFIC OPERATING IN THE OPPOSING DIRECTION, YELLOW PAVEMENT MARKING SHALL BE APPLIED TO THE FLAT PORTION OF THE CONCRETE CORRUGATED MEDIAN. THE ITEM OF PAVEMENT MARKING, CONCRETE CORRUGATED MEDIAN, WILL BE MEASURED IN PLACE AND ACCEPTED IN ACCORDANCE WITH THE CONTRACT AND PAID FOR AT THE CONTRACT UNIT PRICE PER SQUARE FOOT.

- ① APPLY PAVEMENT MARKING TO THE FLAT PORTION OF CORRUGATED MEDIAN.

-  ISLAND NOSE MARKING
-  CURB MARKING
-  CORRUGATED MEDIAN MARKING
-  DIRECTION OF TRAVEL

**PAVEMENT MARKINGS,
MEDIAN ISLAND NOSE**

STATE OF WISCONSIN
DEPARTMENT OF TRANSPORTATION

APPROVED
May 2023 /S/ Jeannie Silver
DATE STATE SIGNING AND MARKING
ENGINEER

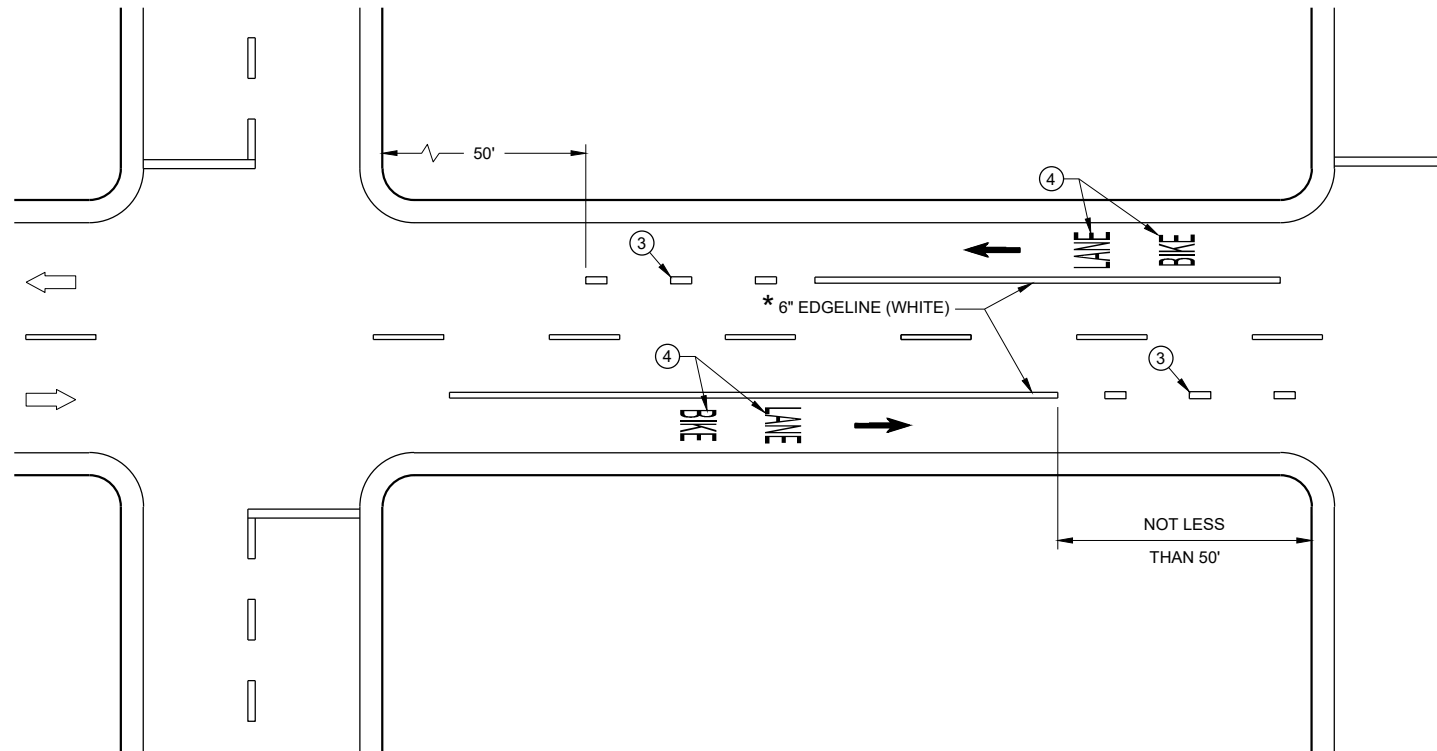

DESIGNATED BIKE LANE - NO PARKING

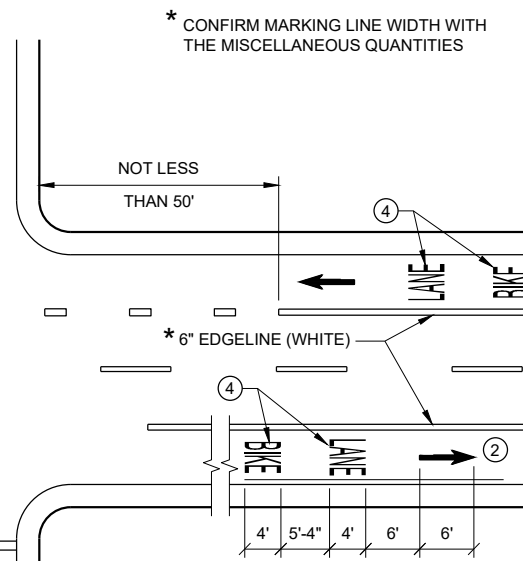

4 LANE DIVIDED WITHOUT ISLAND

- GENERAL NOTES**
- ① DETAILS OF CONSTRUCTION NOT SHOWN ON THIS DRAWING SHALL CONFORM TO STANDARD SPECIFICATIONS AND SPECIAL PROVISIONS.
 - ② MINIMUM OF ONE PER BLOCK. MAXIMUM OF 250 FEET.
 - ③ DOTTED LINES (3' LINE, 9' GAP) SHOULD BE USED 50 FEET TO 200 FEET IN ADVANCE OF AN INTERSECTION WHERE THERE IS NO RIGHT TURN ONLY LANE AND THERE IS HEAVY RIGHT TURN TRAFFIC OR THERE IS A NEAR-SIDE BUS STOP. AT OTHER INTERSECTIONS WHERE RIGHT TURN TRAFFIC IS LIGHT TO MODERATE, A SOLID LINE CAN BE USED UP TO THE INTERSECTION.
 - ④ BIKE SYMBOLS OR WORDS MAY BE USED.
 - ⑤ BIKE ACCOMMODATION IS TYPICAL 5 FEET WIDE AND MINIMUM OF 4 FEET FROM A LONGITUDINAL JOINT. USE 5 FEET AT ≥ 45 MPH.
 - ⑥ OMIT THESE MARKINGS FOR WIDER TURN LANE APPLICATIONS (MINIMUM OF 15 FOOT WIDE TURN LANE).
 - ⑦ REFER TO CONTRACT PLANS FOR LANE WIDTH.

➔ DIRECTION OF TRAVEL

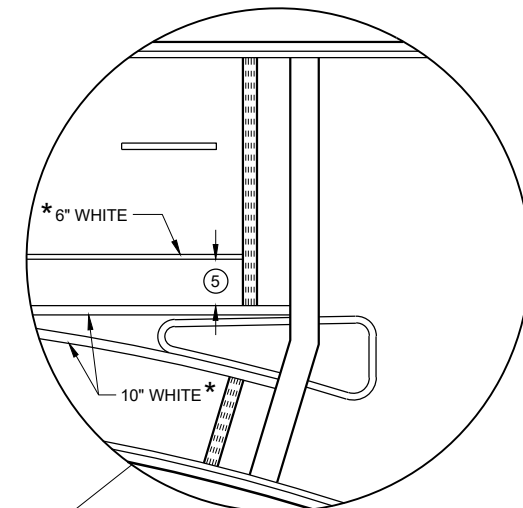
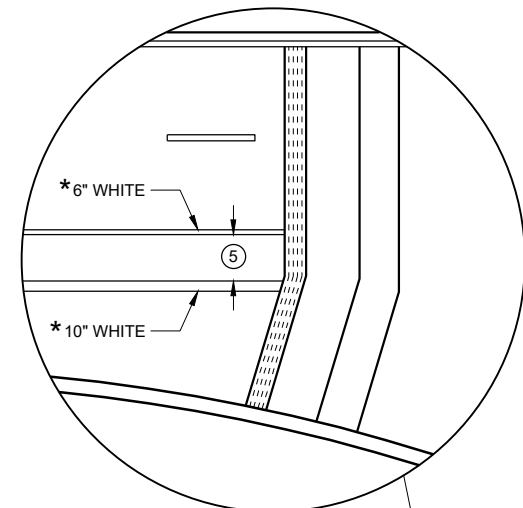

4 LANE DIVIDED WITH ISLAND

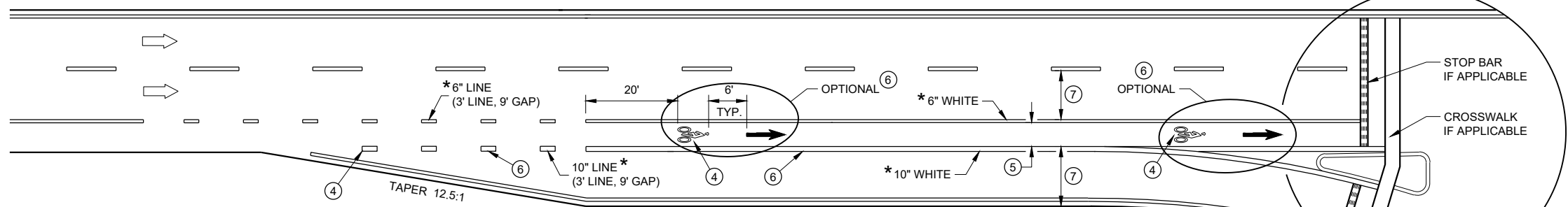

BIKE LANE - FOR 2-LANE ROADWAYS AND 4-LANE DIVIDED ROADWAYS (4-LANE DIVIDED WITH RIGHT TURN LANE SHOWN)

BIKE LANE MARKING	
STATE OF WISCONSIN DEPARTMENT OF TRANSPORTATION	
APPROVED May 2023 DATE	/S/ Matthew Rauch STATE SIGNING AND MARKING ENGINEER
<small>FHWA</small>	

GENERAL NOTES

STOP SIGN SHALL BE PLACED A MINIMUM OF 6 FEET TO A MAXIMUM OF 50 FEET FROM THE EDGELINE LOCATION.

- ① 18-INCH STOP LINES MAY BE DELETED OR ADDED BY THE REGION MARKING ENGINEER BASED ON VISIBILITY AND SIGHT LINES.
- ② NO STOP LINE IS REQUIRED IF STOP SIGN IS LESS THAN OR EQUAL TO 40 FEET FROM THE EDGELINE.
- ③ NO STOP LINE IS REQUIRED IF STOP SIGN IS LESS THAN OR EQUAL TO 30 FEET FROM THE FLANGELINE EXTENSION.
- ④ MOVE CLOSER TO THE EDGE OF TRAVEL LINE AS NEEDED FOR VISIBILITY AND SIGHT LINES (NO CLOSER THAN 4 FEET).
- ⑤ LADDER BAR CROSSWALKS SHOULD ONLY BE USED FOR MID BLOCK CROSSINGS. USE 2 - 6" TRANSVERSE LINES INSTEAD.

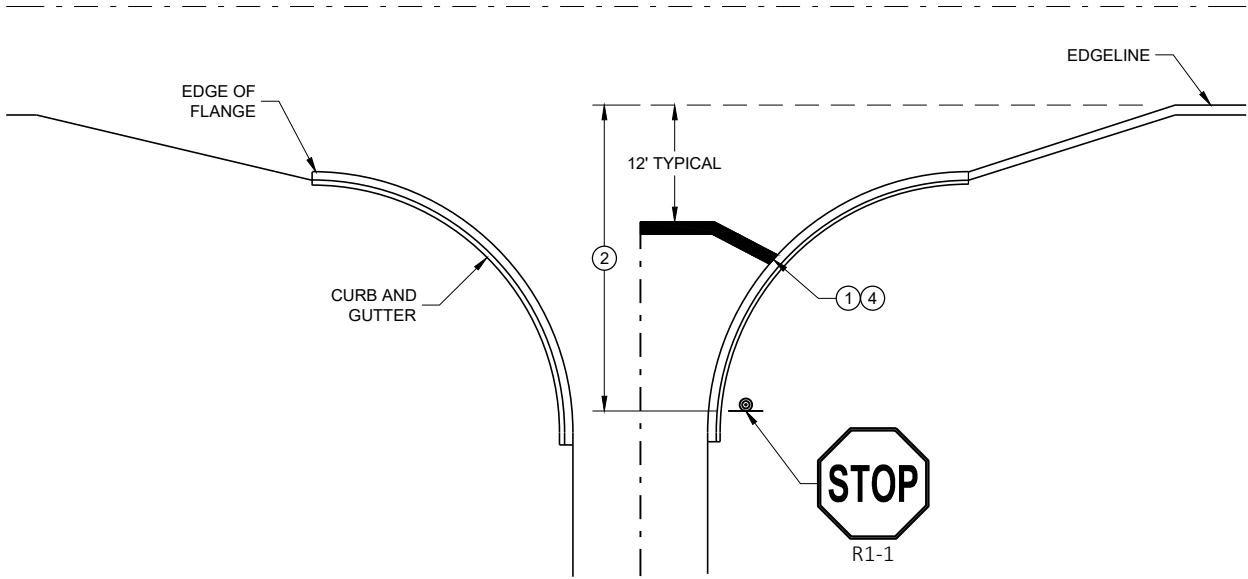

TYPICAL STOP LINE PAVEMENT MARKING WITH CURB AND GUTTER

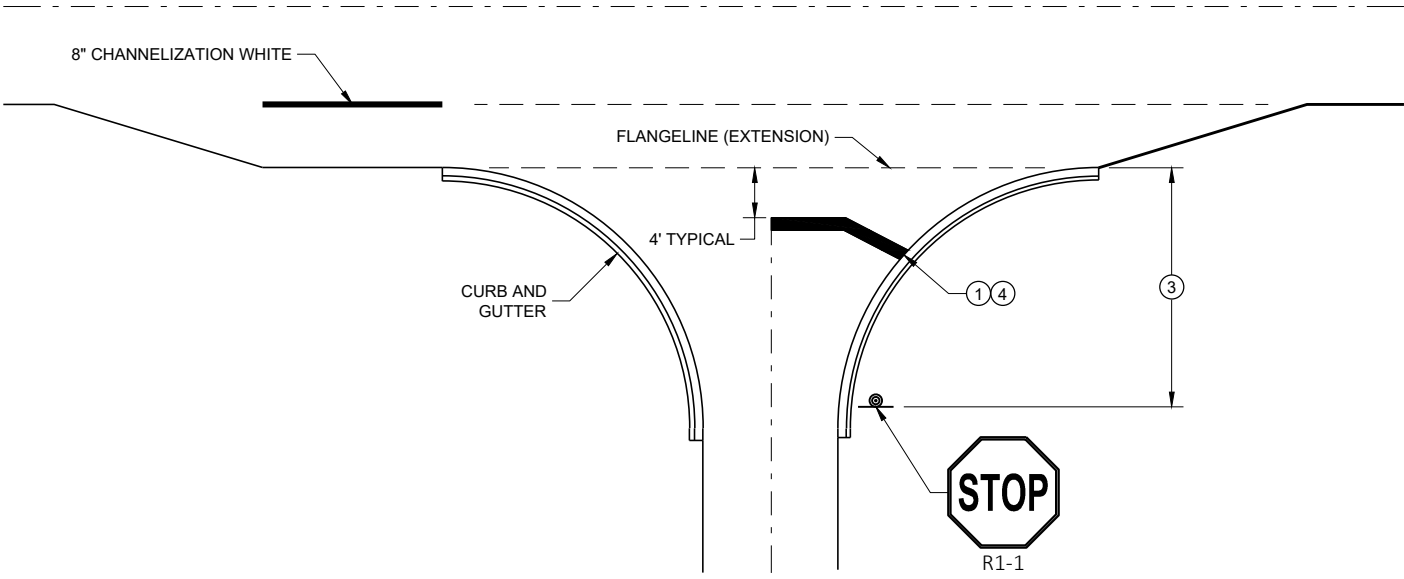

TYPICAL STOP LINE PAVEMENT MARKING FOR SIDEROADS WITH RIGHT TURN LANE

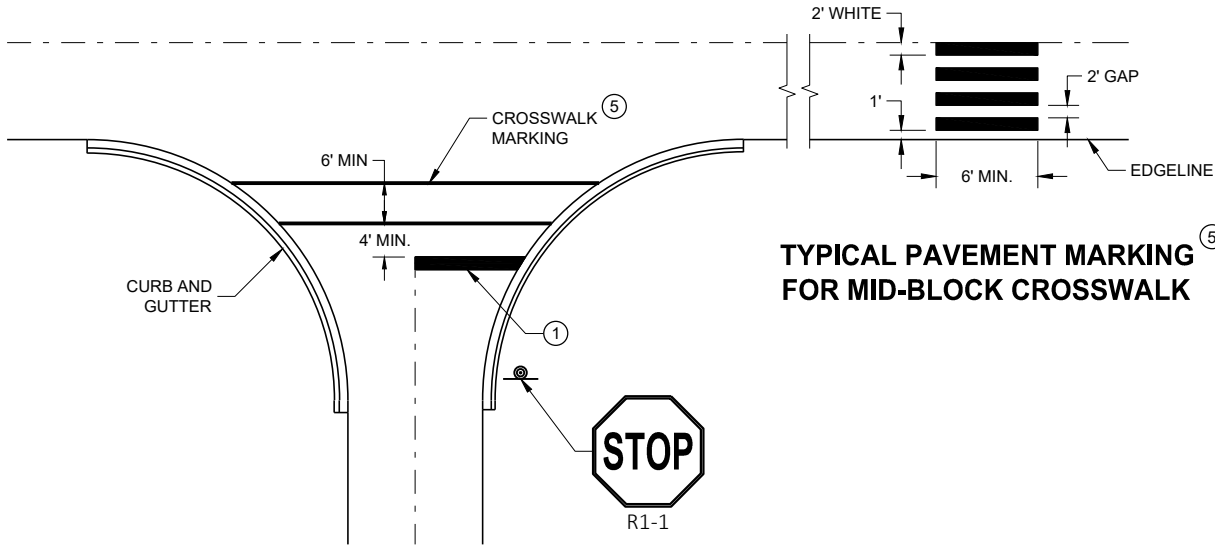

TYPICAL STOP LINE PAVEMENT MARKING FOR SIDEROADS WITH CROSSWALK MARKING

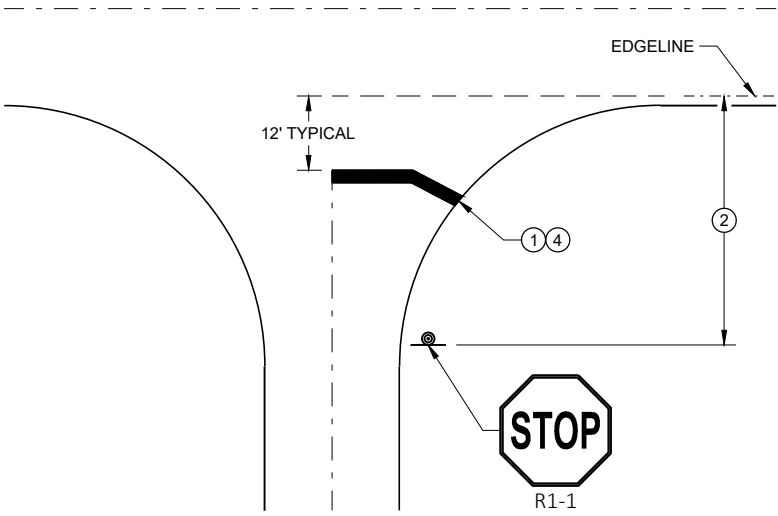

TYPICAL STOP LINE PAVEMENT MARKING WITHOUT CURB AND GUTTER

TYPICAL PAVEMENT MARKING FOR MID-BLOCK CROSSWALK

STOP LINE AND CROSSWALK PAVEMENT MARKING

STATE OF WISCONSIN
DEPARTMENT OF TRANSPORTATION

APPROVED
November 2019 /S/ Matthew Rauch
DATE STATE SIGNING AND MARKING ENGINEER

FHWA

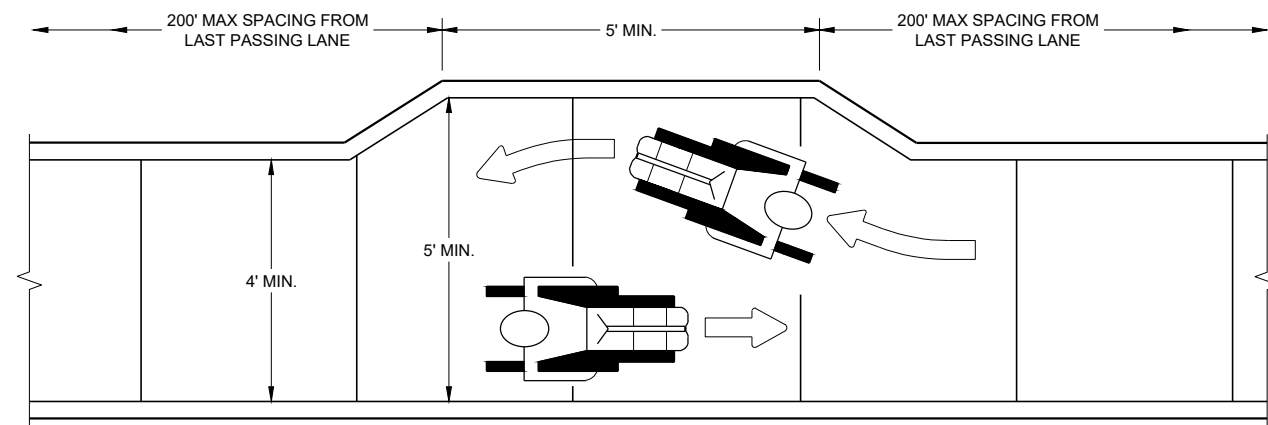

NARROW SIDEWALK PASSING DETAIL

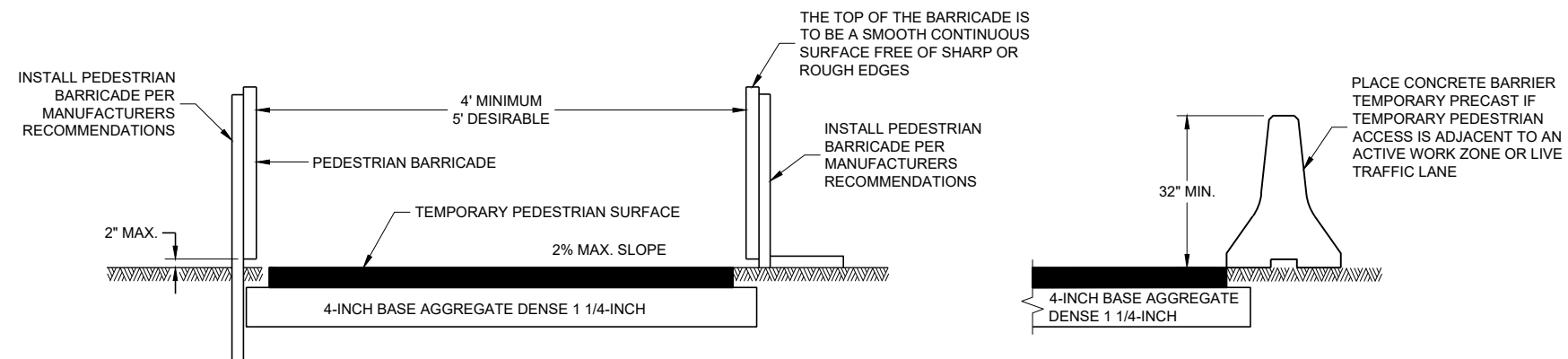

TEMPORARY PEDESTRIAN ACCESS

GENERAL NOTES

- BARRICADE DEVICE SELECTED FROM APPROVED PRODUCT LIST
- ① REFLECTIVE SHEETING SHALL FOLLOW THE REQUIREMENTS IN THE APPROVED PRODUCTS LISTING FOR SIGN SHEETING.
- ② SHEETING REQUIRED ON MORE THAN 50% OF BARRICADE WIDTH.
- ③ PLACE SHEETING ON BOTH SIDES OF THE BARRICADE.
- * USE THIS DETAIL FOR SHEETING PLACEMENT REFERENCE.

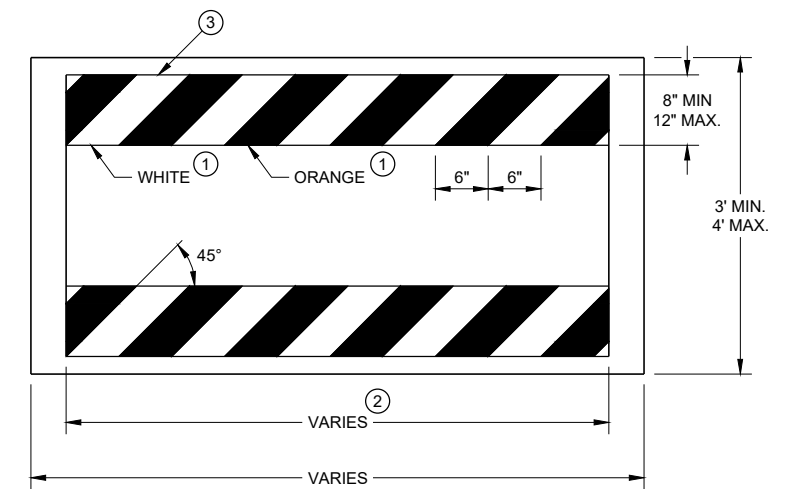

TEMPORARY PEDESTRIAN BARRICADE*

GENERAL NOTES

CURB RAMPS SHALL BE 48" MIN. WIDTH WITH A FIRM, STABLE AND SLIP RESISTANT SURFACE.
 CURB RAMPS AND LANDINGS SHALL HAVE A 1:50 (2%) MAX. CROSS-SLOPE.
 CLEAR SPACE OF 48" X 48" SHALL BE PROVIDED ABOVE AND BELOW THE CURB RAMP.
 LATERAL JOINTS OR GAPS BETWEEN SURFACES SHALL BE LESS THAN 1/2" WIDTH.
 CHANGES BETWEEN SURFACE HEIGHTS SHALL NOT EXCEED 1/2". LATERAL EDGES MAY BE VERTICAL UP TO 1/4" HIGH AND SHALL BE BEVELED AT 1:2 BETWEEN 1/4" AND 1/2".

- ① INSTALL CONTRASTING TEMPORARY DETECTABLE WARNING FIELD AT PEDESTRIAN STREET CROSSINGS, AS SHOWN IN THE PLANS.
- ② PROTECTIVE EDGING WITH A 2" MIN. HEIGHT SHALL BE INSTALLED WHEN A CURB RAMP OR LANDING PLATFORM HAS A VERTICAL DROP OF 6" OR GREATER OR HAS A SIDE APRON SLOPE STEEPER THAN 1:3 (33%). PROTECTIVE EDGING SHOULD BE CONSIDERED WHEN CURB RAMPS OR LANDING PLATFORMS HAVE A VERTICAL DROP OF 3" OR MORE.
- ③ DETECTABLE EDGING WITH 6" MIN. HEIGHT AND CONTRASTING COLOR SHALL BE INSTALLED ON ALL CURB RAMP LANDINGS WHERE THE WALKWAY CHANGES DIRECTION (TURNS).
- ④ DO NOT RESTRICT WATER FLOW IN THE GUTTER SYSTEM.
- ⑤ ENSURE CURB RAMP IS OUT OF THE GUTTER PAN.
- ⑥ IF ONLY PART OF THE END PANEL OF TEMPORARY PEDESTRIAN BARRICADE PANEL IS NEEDED, EXTEND EXCESS PORTION OF TEMPORARY PEDESTRIAN BARRICADE PANEL HERE.

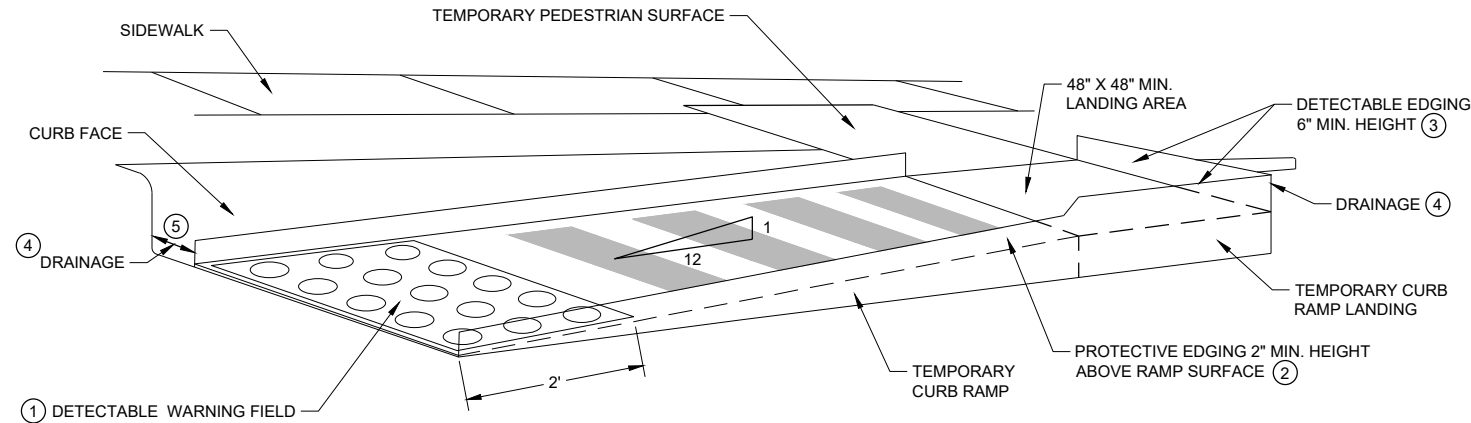

PERSPECTIVE VIEW

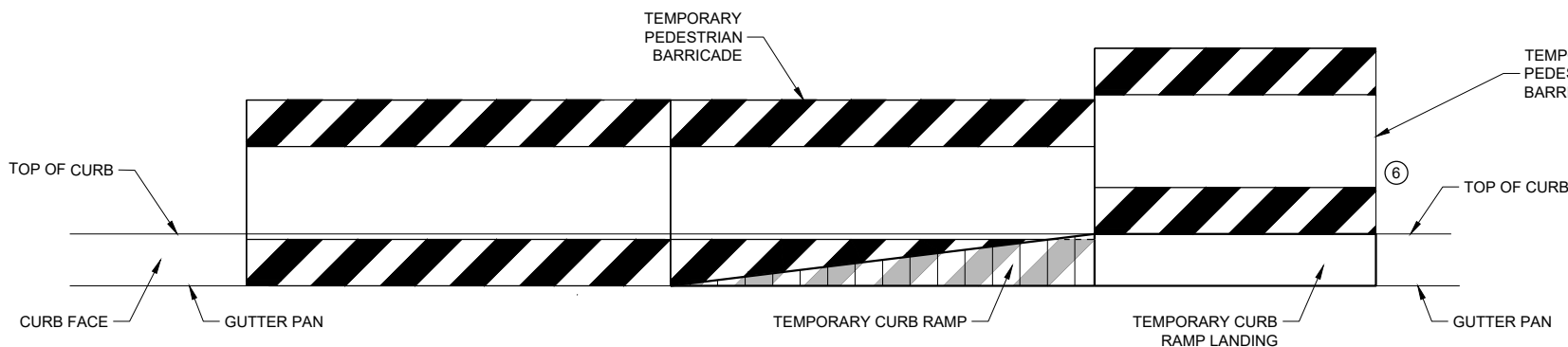

FRONT VIEW

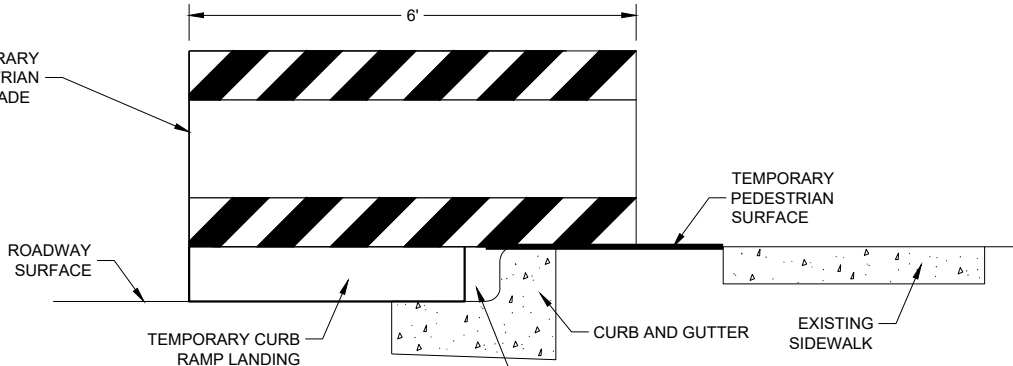

SIDE VIEW

TEMPORARY CURB RAMP PARALLEL TO CURB

<p>TRAFFIC CONTROL, PEDESTRIAN ACCOMMODATION</p>
<p>STATE OF WISCONSIN DEPARTMENT OF TRANSPORTATION</p>

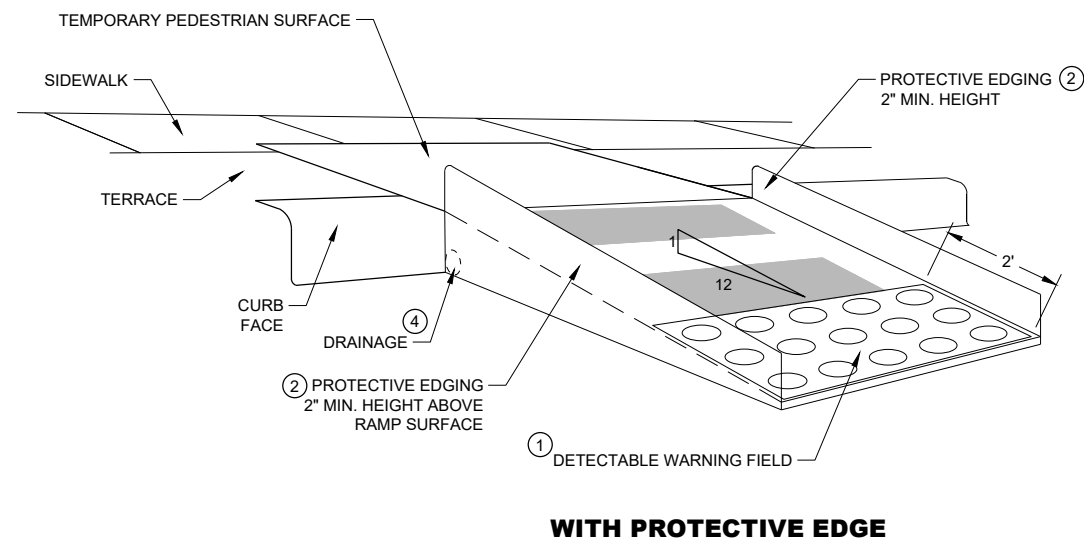
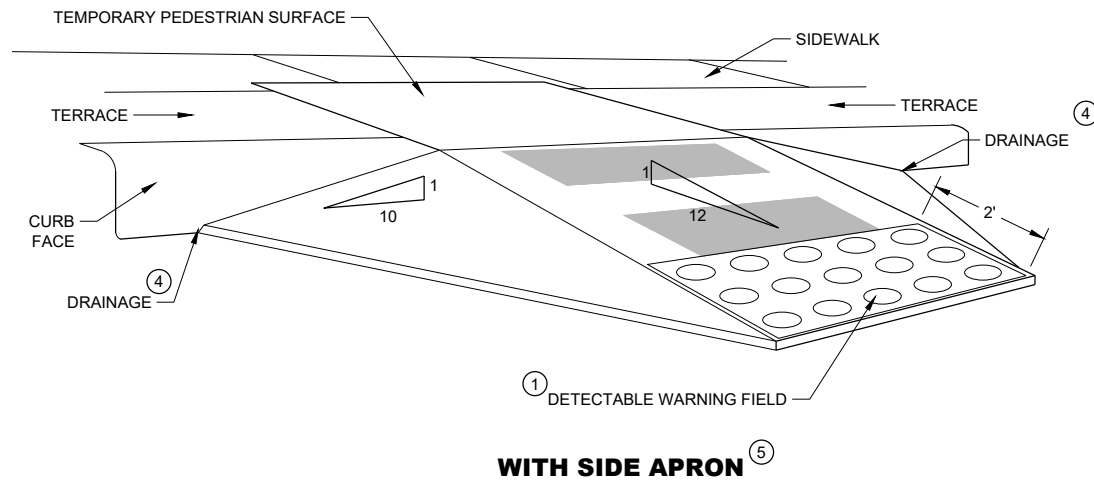

TEMPORARY CURB RAMP PERPENDICULAR TO CURB

GENERAL NOTES

CURB RAMPS SHALL BE 48" MINIMUM WIDTH WITH A FIRM, STABLE AND SLIP RESISTANT SURFACE.

ALTERNATE SIDEWALK WORK BETWEEN LEFT AND RIGHT SIDE OF ROADWAY TO MAINTAIN PEDESTRIAN ACCESS.

CURB RAMPS AND LANDINGS SHALL HAVE A 1:50 (2%) MAX. CROSS-SLOPE.

CLEAR SPACE OF 48" X 48" SHALL BE PROVIDED ABOVE AND BELOW THE CURB RAMP.

LATERAL JOINTS OR GAPS BETWEEN SURFACES SHALL BE LESS THAN 1/2" WIDTH.

CHANGES BETWEEN SURFACE HEIGHTS SHALL NOT EXCEED 1/2". LATERAL EDGES MAY BE VERTICAL UP TO 1/4" HIGH AND SHALL BE BEVELED AT 1:2 BETWEEN 1/4" AND 1/2".

- ① INSTALL CONTRASTING TEMPORARY DETECTABLE WARNING FIELD AT PEDESTRIAN STREET CROSSINGS, AS SHOWN IN THE PLANS
- ② PROTECTIVE EDGING WITH A 2" MIN. HEIGHT SHALL BE INSTALLED WHEN A CURB RAMP OR LANDING PLATFORM HAS A VERTICAL DROP OF 6" OR GREATER OR HAS A SIDE APRON SLOPE STEEPER THAN 1:3 (33%). PROTECTIVE EDGING SHOULD BE CONSIDERED WHEN CURB RAMPS OR LANDING PLATFORMS HAVE A VERTICAL DROP OF 3" OR MORE.
- ③ DETECTABLE EDGING WITH 6" MIN. HEIGHT AND CONTRASTING COLOR SHALL BE INSTALLED ON ALL CURB RAMP LANDINGS WHERE THE WALKWAY CHANGES DIRECTION (TURNS).
- ④ DO NOT RESTRICT WATER FLOW IN THE GUTTER SYSTEM.
- ⑤ CAN ONLY BE USED FOR RAMPS WITH 6" OR LESS OF VERTICAL CHANGE.

GENERAL NOTES

- BARRICADE DEVICE SELECTED FROM APPROVED PRODUCT LIST
- ① REFLECTIVE SHEETING SHALL FOLLOW THE REQUIREMENTS IN THE APPROVED PRODUCTS LISTING FOR SIGN SHEETING.
- ② SHEETING REQUIRED ON MORE THAN 50% OF BARRICADE WIDTH.
- ③ PLACE SHEETING ON BOTH SIDES OF THE BARRICADE.
- ★ USE THIS DETAIL FOR SHEETING PLACEMENT REFERENCE.

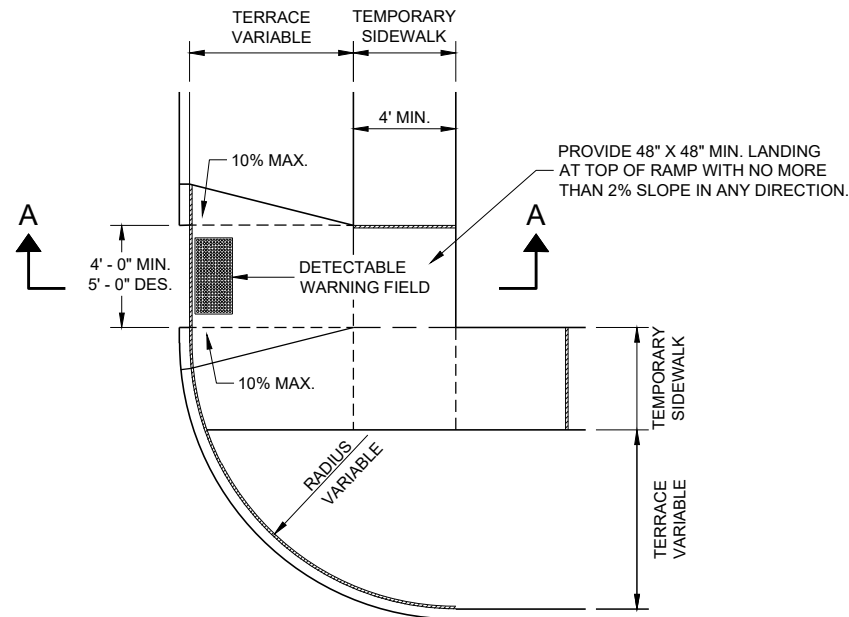
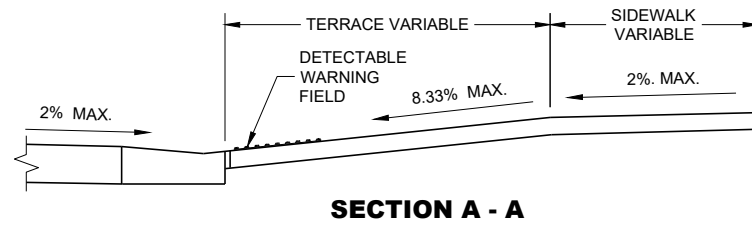

PLAN VIEW
TEMPORARY TYPE 3 RAMP
 (OUTSIDE OF CROSSWALK AREA)

6

6

SDD 15D30-09d

SDD 15D30-09d

TRAFFIC CONTROL, PEDESTRIAN ACCOMMODATION	
STATE OF WISCONSIN DEPARTMENT OF TRANSPORTATION	
APPROVED May 2023 DATE	/S/ Andrew Heidtke WORK ZONE ENGINEER
FHWA	

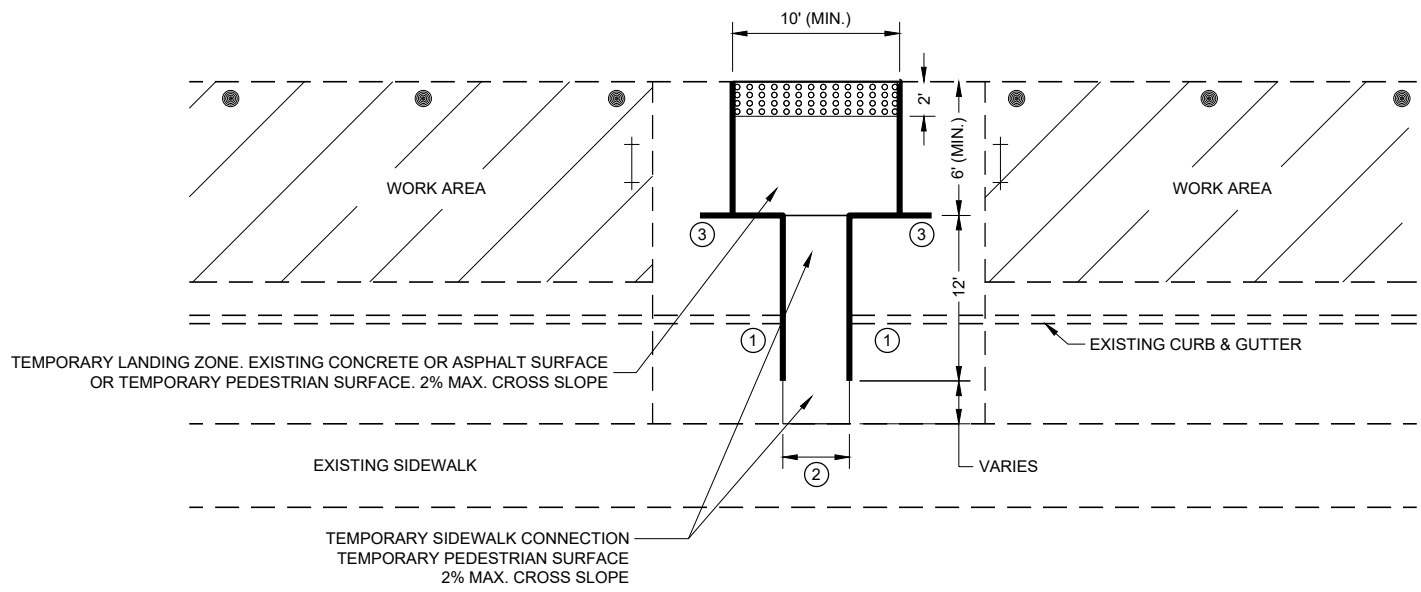

PLAN VIEW

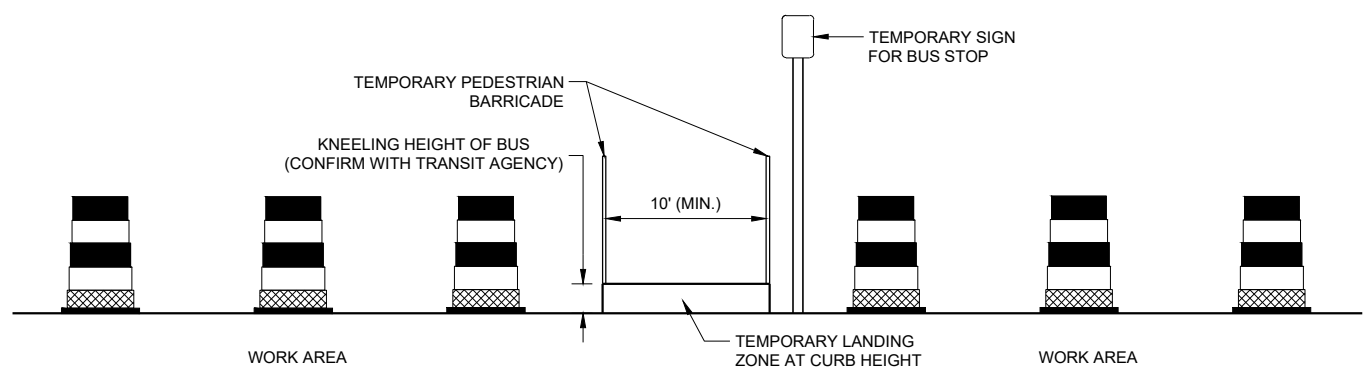

PROFILE VIEW
TEMPORARY BUS STOP PAD

GENERAL NOTES

- TYPICAL TEMPORARY PEDESTRIAN BARRICADE PANEL IS 6 FEET LONG.
- NOTIFY THE BUS COMPANY 7 DAYS IN ADVANCE OF THE BUS STOP RELOCATION.
- PROTECTIVE EDGING WITH A 2" MIN. HEIGHT SHALL BE INSTALLED WHEN A CURB RAMP OR LANDING PLATFORM HAS A VERTICAL DROP OF 6" OR GREATER OR HAS A SIDE APRON SLOPE STEEPER THAN 1:3 (33%). PROTECTIVE EDGING SHOULD BE CONSIDERED WHEN CURB RAMP OR LANDING PLATFORMS HAVE A VERTICAL DROP OF 3" OR MORE.
- DETECTABLE EDGING WITH 6" MIN. HEIGHT AND CONTRASTING COLOR SHALL BE INSTALLED ON ALL CURB RAMP LANDINGS WHERE THE WALKWAY CHANGES DIRECTION (TURNS).
- LATERAL JOINTS OR GAPS BETWEEN SURFACES SHALL BE LESS THAN 1/2" WIDTH.
- CHANGES BETWEEN SURFACE HEIGHTS SHALL NOT EXCEED 1/2". LATERAL EDGES MAY BE VERTICAL UP TO 1/4" HIGH AND SHALL BE BEVELED AT 1:2 BETWEEN 1/4" AND 1/2".
- CURB RAMP AND LANDINGS SHALL HAVE A 1:50 (2%) MAX. CROSS-SLOPE.

- ① DO NOT RESTRICT WATER FLOW IN THE GUTTER SYSTEM.
- ② 5' WIDE MIN. WITH TEMPORARY PEDESTRIAN BARRICADE, 10' WIDE MIN. WITHOUT TEMPORARY PEDESTRIAN BARRICADE.
- ③ PLACE EXCESS PORTION OF TEMPORARY PEDESTRIAN BARRICADE INTO THIS SPACE.







LEGEND

- TRAFFIC CONTROL DRUM
- ⊥ TYPE III BARRICADE
- TEMPORARY PEDESTRIAN BARRICADE
- ▤ TEMPORARY DETECTABLE WARNING FIELD
- ▨ WORK AREA

**TRAFFIC CONTROL,
PEDESTRIAN ACCOMMODATION**

STATE OF WISCONSIN
DEPARTMENT OF TRANSPORTATION

LEGEND

-  SIGN ON PERMANENT SUPPORT
-  SIGN ON TEMPORARY SUPPORT
-  UNDER PEDESTRIAN TRAFFIC
-  WORK AREA
-  TEMPORARY PEDESTRIAN BARRICADE
-  DIRECTION OF TRAFFIC

GENERAL NOTES



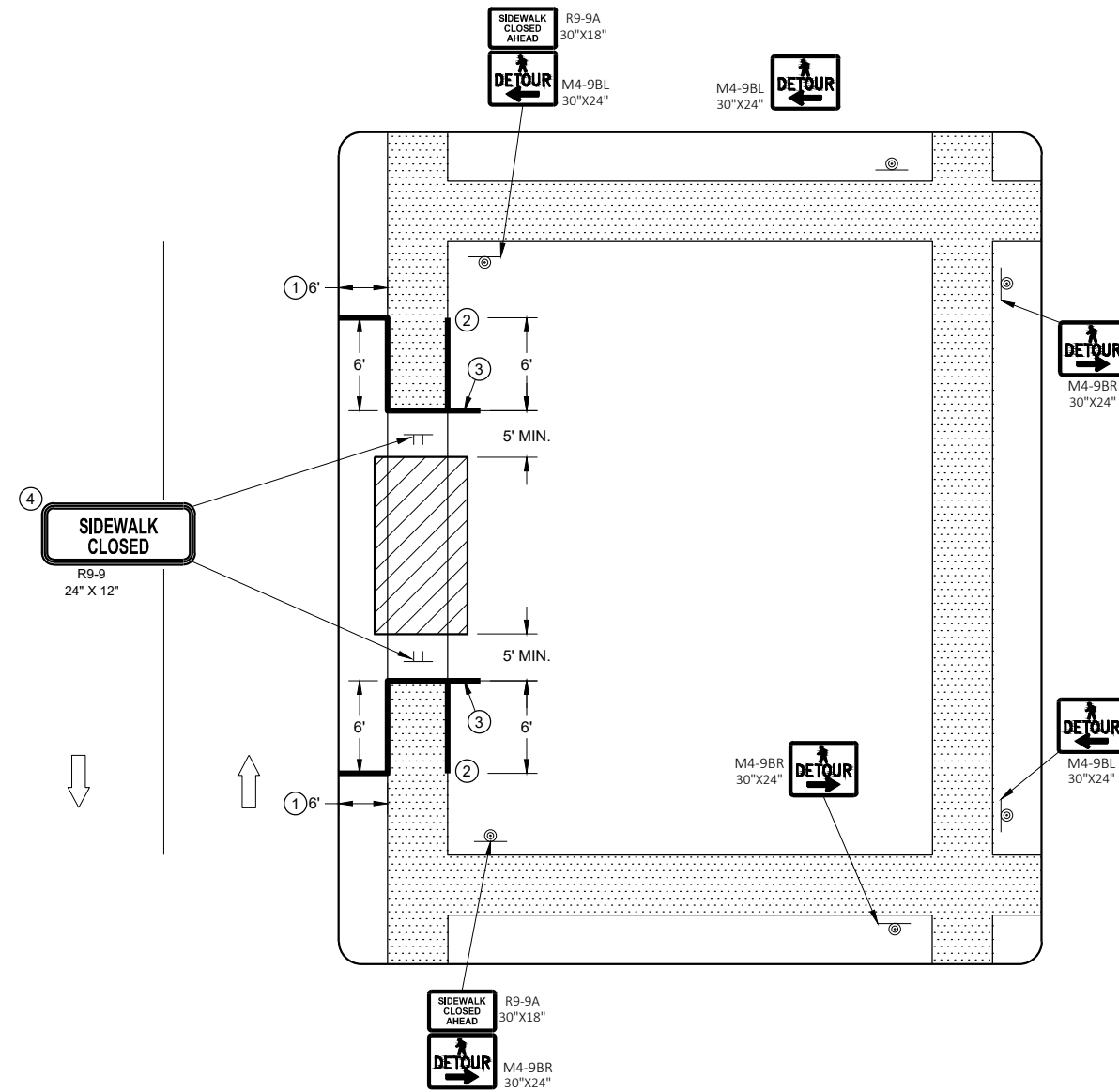



- SIGN LAYOUTS SHALL BE IN ACCORDANCE WITH THE WISCONSIN STANDARD SIGN PLATES.
- WHERE TEMPORARY BARRICADE RUNS PARALLEL ALONG SIDEWALK, PLACE THE FACE OF THE BARRICADE AT THE EDGE OF THE SIDEWALK.
- SIGNS THAT REMAIN IN PLACE LESS THAN SEVEN CONTINUOUS DAYS AND NIGHTS MAY BE MOUNTED ON PORTABLE SUPPORTS.
- PLACE TEMPORARY PEDESTRIAN BARRICADE TO FIT FIELD CONDITIONS, AVOIDING CONFLICTS WITH DRIVEWAYS AND OTHER EXISTING FEATURES.
- ① IF TERRACE IS LESS THAN 6 FEET WIDE, OMIT TEMPORARY PEDESTRIAN BARRICADE FROM THE SIDEWALK TO THE CURB.
 - ② PLACE BARRICADE CLOSURE SO THAT THE TEMPORARY PEDESTRIAN BARRICADE END IS AT THE LAST OPEN SIDEWALK ACCESS TO RESIDENCES OR BUSINESSES BEFORE THE SIDEWALK CLOSURE.
 - ③ IF TEMPORARY PEDESTRIAN BARRICADE PANEL IS WIDER THAN THE SIDEWALK WIDTH, THE PORTION OF EXCESS PANEL SHOULD EXTEND INTO THE TERRACE.
 - ④ MOUNTING HEIGHT OF 5 FEET FROM THE SURFACE TO THE BOTTOM OF SIGN.



SIDEWALK DETOUR, SIDEWALK ONLY ON ONE SIDE

TRAFFIC CONTROL, PEDESTRIAN ACCOMMODATION
STATE OF WISCONSIN DEPARTMENT OF TRANSPORTATION

LEGEND

-  SIGN ON TEMPORARY SUPPORT
-  WORK AREA
-  UNDER PEDESTRIAN TRAFFIC
-  TEMPORARY PEDESTRIAN SURFACE
-  TEMPORARY PEDESTRIAN BARRICADE
-  OPTIONAL TEMPORARY PEDESTRIAN BARRICADE
-  DIRECTION OF TRAFFIC





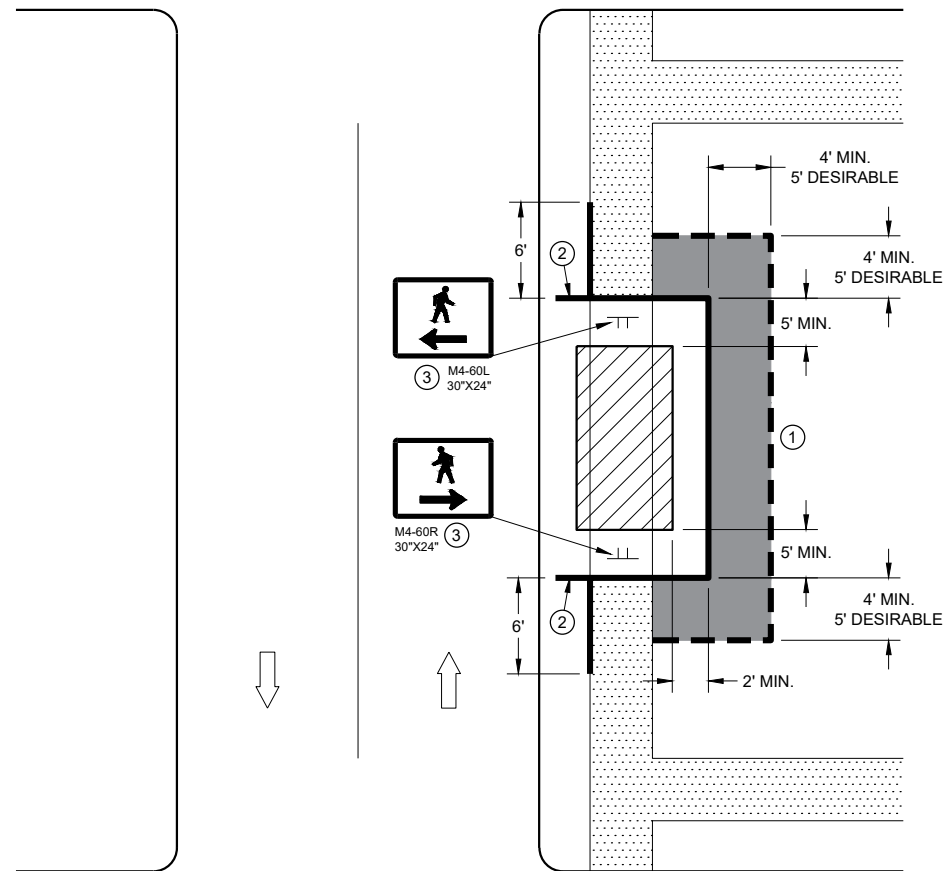



GENERAL NOTES

- TYPICAL TEMPORARY PEDESTRIAN BARRICADE PANEL IS 6 FEET LONG.
- SIGN LAYOUTS SHALL BE IN ACCORDANCE WITH THE WISCONSIN STANDARD SIGN PLATES.
- WHERE TEMPORARY BARRICADE RUNS PARALLEL ALONG SIDEWALK, PLACE THE FACE OF THE BARRICADE AT THE EDGE OF THE SIDEWALK.
- SIGNS THAT REMAIN IN PLACE LESS THAN SEVEN CONTINUOUS DAYS AND NIGHTS MAY BE MOUNTED ON PORTABLE SUPPORTS.
- ① USE TEMPORARY PEDESTRIAN BARRICADE TO SEPARATE PEDESTRIANS FROM DROP OFFS OR FOR ADDITIONAL PEDESTRIAN CHANNELIZATION.
 - ② IF TEMPORARY PEDESTRIAN BARRICADE PANEL IS WIDER THAN THE SIDEWALK WIDTH, THE PORTION OF EXCESS PANEL SHOULD EXTEND INTO THE TERRACE.
 - ③ MOUNTING HEIGHT OF 5 FEET FROM THE SURFACE TO THE BOTTOM OF SIGN.



**SIDEWALK DIVERSION
SINGLE SIDE**

LEGEND

-  SIGN ON TEMPORARY SUPPORT
-  TRAFFIC CONTROL DRUM
-  WORK AREA
-  UNDER PEDESTRIAN TRAFFIC
-  TEMPORARY CURB RAMP
-  TEMPORARY PEDESTRIAN SURFACE "A"
-  TEMPORARY PEDESTRIAN SURFACE "B"
-  TEMPORARY PEDESTRIAN BARRICADE
-  DIRECTION OF TRAFFIC

GENERAL NOTES

- TYPICAL TEMPORARY PEDESTRIAN BARRICADE PANEL IS 6 FEET LONG.
- SIGN LAYOUTS SHALL BE IN ACCORDANCE WITH THE WISCONSIN STANDARD SIGN PLATES.
- WHERE TEMPORARY BARRICADE RUNS PARALLEL ALONG SIDEWALK, PLACE THE FACE OF THE BARRICADE AT THE EDGE OF THE SIDEWALK.
- ① SHOULDER OR LANE CLOSURE ADVANCE WARNING AND BUFFER SPACE REQUIRED.
 - ② PLACE EXCESS PORTION OF TEMPORARY PEDESTRIAN BARRICADE PANEL PAST THE SIDEWALK ON THE SIDE AWAY FROM THE ROAD.
 - ③ MOUNTING HEIGHT OF 5 FEET FROM THE SURFACE TO THE BOTTOM OF SIGN.
 - ④ USE EXISTING PAVEMENT SURFACE. IF EXISTING PAVEMENT SURFACE HAS BEEN REMOVED, USE A TEMPORARY PEDESTRIAN SURFACE.

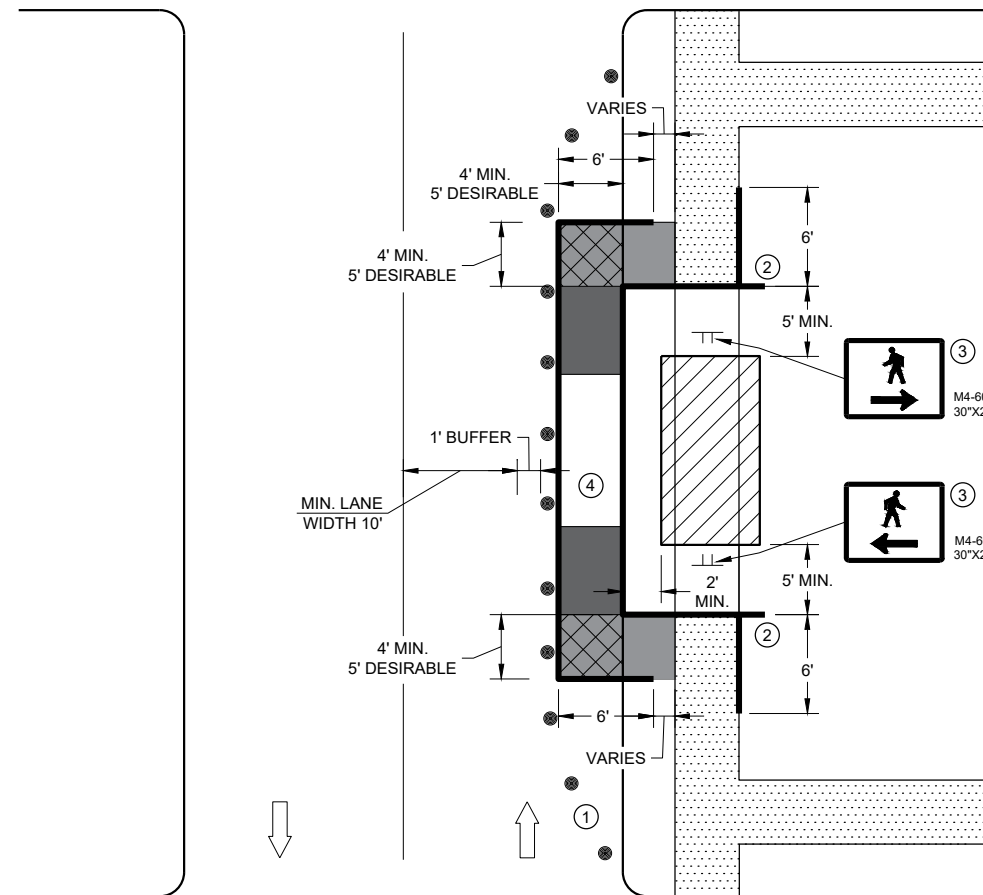

SIDEWALK DIVERSION, SINGLE SIDE

TRAFFIC CONTROL, PEDESTRIAN ACCOMMODATION
STATE OF WISCONSIN DEPARTMENT OF TRANSPORTATION

6

6

SDD 15D30 - 09h

SDD 15D30 - 09h

GENERAL NOTES

IF PEDESTRIAN PUSH BUTTONS ARE PRESENT ON THE EXISTING FACILITY, ENSURE THEY ARE MAINTAINED/ACCESSIBLE FOR PEDESTRIAN USE THROUGHOUT THE TEMPORARY PEDESTRIAN ACCOMMODATIONS.











SIGN LAYOUTS SHALL BE IN ACCORDANCE WITH THE WISCONSIN STANDARD SIGN PLATES.

TYPICAL TEMPORARY PEDESTRIAN BARRICADE PANEL IS 6 FEET LONG

WHEN TEMPORARY PEDESTRIAN BARRICADE RUNS PARALLEL ALONG THE SIDEWALK, PLACE THE FACE OF THE BARRICADE AT THE EDGE OF THE SIDEWALK.

- ① SHOULDER OR LANE CLOSURE ADVANCE WARNING AND PROPER BUFFER SPACE REQUIRED.
- ② PROVIDE ADEQUATE SPACE FOR CONTRACTOR OPERATIONS
- ③ USE TEMPORARY PEDESTRIAN BARRICADE TO SEPARATE PEDESTRIANS FROM DROP OFFS OR FOR ADDITIONAL PEDESTRIAN CHANNELIZATION.
- ④ MOUNTING HEIGHT OF 5 FEET FROM SIDEWALK SURFACE TO BOTTOM OF SIGN.
- ⑤ PLACE EXCESS PORTION OF TEMPORARY PEDESTRIAN BARRICADE PANEL IN THE SIDEWALK TERRACE.
- ⑥ IF TEMPORARY PEDESTRIAN BARRICADE DOES NOT REACH THE FACE OF THE CURB, USE AN ADDITIONAL PANEL AND EXTEND INTO THE TERRACE.
- ⑦ 4 FEET MINIMUM, 5 FEET DESIRABLE
- ⑧ IF MINIMUM LANE WIDTHS CAN'T BE ATTAINED, CURB RAMPS MAY NEED TO BE CONSTRUCTED AT SEPARATE TIMES.

LEGEND

-  SIGN ON TEMPORARY SUPPORT
-  TRAFFIC CONTROL DRUM
-  WORK AREA
-  TEMPORARY CURB RAMP
-  TEMPORARY PEDESTRIAN SURFACE "A"
-  TEMPORARY PEDESTRIAN SURFACE "B"
-  TEMPORARY DETECTABLE WARNING FIELD
-  TEMPORARY PEDESTRIAN BARRICADE
-  OPTIONAL TEMPORARY PEDESTRIAN BARRICADE
-  DIRECTION OF TRAFFIC

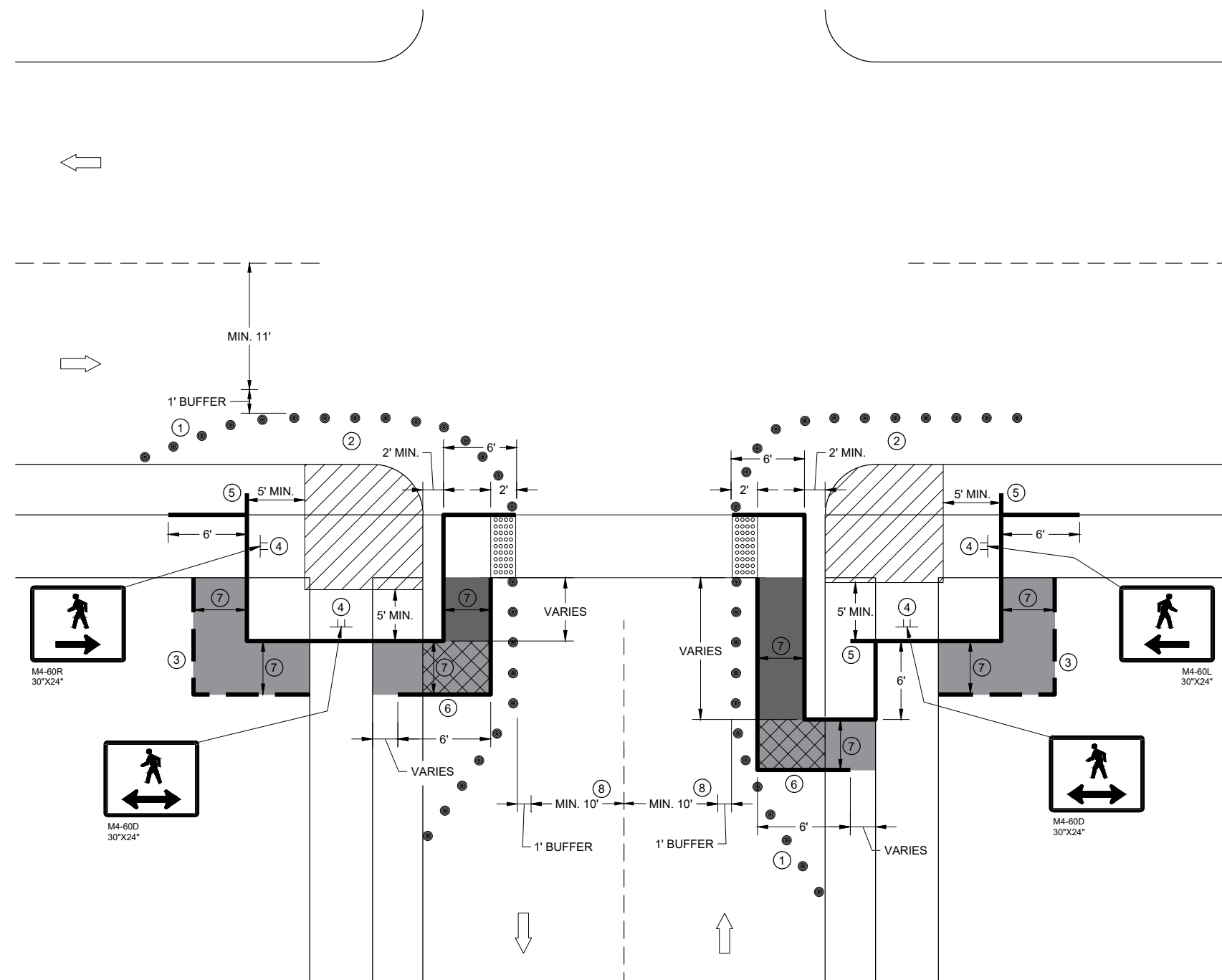

**CURB RAMP PEDESTRIAN TRAFFIC CONTROL
SIDEWALK ON SINGLE SIDE**

TRAFFIC CONTROL, PEDESTRIAN ACCOMMODATION
STATE OF WISCONSIN DEPARTMENT OF TRANSPORTATION

GENERAL NOTES

IF PEDESTRIAN PUSH BUTTONS ARE PRESENT ON THE EXISTING FACILITY, ENSURE THEY ARE MAINTAINED/ACCESSIBLE FOR PEDESTRIAN USE THROUGHOUT THE TEMPORARY PEDESTRIAN ACCOMMODATIONS.











SIGN LAYOUTS SHALL BE IN ACCORDANCE WITH THE WISCONSIN STANDARD SIGN PLATES.

TYPICAL TEMPORARY PEDESTRIAN BARRICADE PANEL IS 6 FEET LONG

WHEN TEMPORARY PEDESTRIAN BARRICADE RUNS PARALLEL ALONG THE SIDEWALK, PLACE THE FACE OF THE BARRICADE AT THE EDGE OF THE SIDEWALK.

- ① SHOULDER OR LANE CLOSURE ADVANCE WARNING AND PROPER BUFFER SPACE REQUIRED.
- ② PROVIDE ADEQUATE SPACE FOR CONTRACTOR OPERATIONS
- ③ USE TEMPORARY PEDESTRIAN BARRICADE TO SEPARATE PEDESTRIANS FROM DROP OFFS OR FOR ADDITIONAL PEDESTRIAN CHANNELIZATION.
- ④ MOUNTING HEIGHT OF 5 FEET FROM SIDEWALK SURFACE TO BOTTOM OF SIGN.
- ⑤ PLACE EXCESS PORTION OF TEMPORARY PEDESTRIAN BARRICADE PANEL IN THE SIDEWALK TERRACE.
- ⑥ WHITE 6" TEMPORARY PAVEMENT MARKING
- ⑦ IF TEMPORARY PEDESTRIAN BARRICADE DOES NOT REACH THE FACE OF THE CURB, USE AN ADDITIONAL PANEL AND EXTEND INTO THE TERRACE.
- ⑧ 4 FEET MINIMUM, 5 FEET DESIRABLE
- ⑨ IF MINIMUM LANE WIDTHS CAN'T BE ATTAINED, CURB RAMPS MAY NEED TO BE CONSTRUCTED AT SEPARATE TIMES.

LEGEND

-  SIGN ON TEMPORARY SUPPORT
-  TRAFFIC CONTROL DRUM
-  WORK AREA
-  TEMPORARY CURB RAMP
-  TEMPORARY PEDESTRIAN SURFACE "A"
-  TEMPORARY PEDESTRIAN SURFACE "B"
-  TEMPORARY DETECTABLE WARNING FIELD
-  TEMPORARY PEDESTRIAN BARRICADE
-  OPTIONAL TEMPORARY PEDESTRIAN BARRICADE
-  DIRECTION OF TRAFFIC

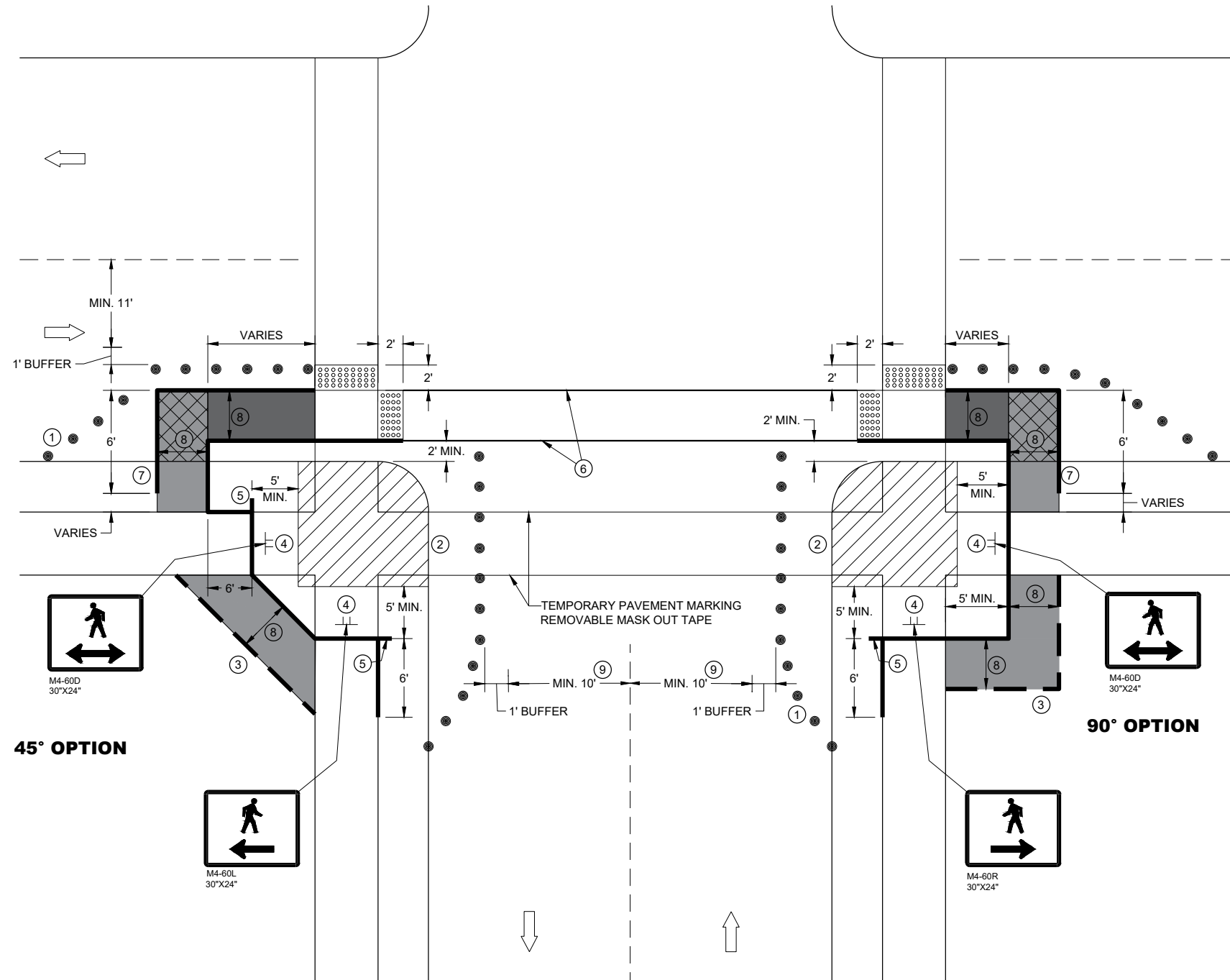







CURB RAMP PEDESTRIAN TRAFFIC CONTROL

**TRAFFIC CONTROL,
PEDESTRIAN ACCOMMODATION**

STATE OF WISCONSIN
DEPARTMENT OF TRANSPORTATION

LEGEND

-  SIGN ON PERMANENT SUPPORT
-  SIGN ON TEMPORARY SUPPORT
-  UNDER PEDESTRIAN TRAFFIC
-  WORK AREA
-  TEMPORARY PEDESTRIAN BARRICADE
-  DIRECTION OF TRAFFIC

GENERAL NOTES

- SIGN LAYOUTS SHALL BE IN ACCORDANCE WITH THE WISCONSIN STANDARD SIGN PLATES.
- WHERE TEMPORARY BARRICADE RUNS PARALLEL ALONG SIDEWALK, PLACE THE FACE OF THE BARRICADE AT THE EDGE OF THE SIDEWALK.
- SIGNS THAT REMAIN IN PLACE LESS THAN SEVEN CONTINUOUS DAYS AND NIGHTS MAY BE MOUNTED ON PORTABLE SUPPORTS.
- PLACE TEMPORARY PEDESTRIAN BARRICADE TO FIT FIELD CONDITIONS, AVOIDING CONFLICT WITH DRIVEWAYS AND OTHER EXISTING FEATURES.
- ① IF TERRACE IS LESS THAN 6 FEET WIDE, OMIT TEMPORARY PEDESTRIAN BARRICADE FROM THE SIDEWALK TO THE CURB.
 - ② PLACE BARRICADE CLOSURE SO THAT THE TEMPORARY PEDESTRIAN BARRICADE END IS AT THE LAST OPEN SIDEWALK ACCESS TO RESIDENCES OR BUSINESSES BEFORE THE SIDEWALK CLOSURE.
 - ③ IF TEMPORARY PEDESTRIAN BARRICADE PANEL IS WIDER THAN THE SIDEWALK WIDTH, THE PORTION OF EXCESS PANEL SHOULD EXTEND INTO THE TERRACE.
 - ④ MOUNTING HEIGHT OF 5 FEET FROM THE SURFACE TO THE BOTTOM OF SIGN.

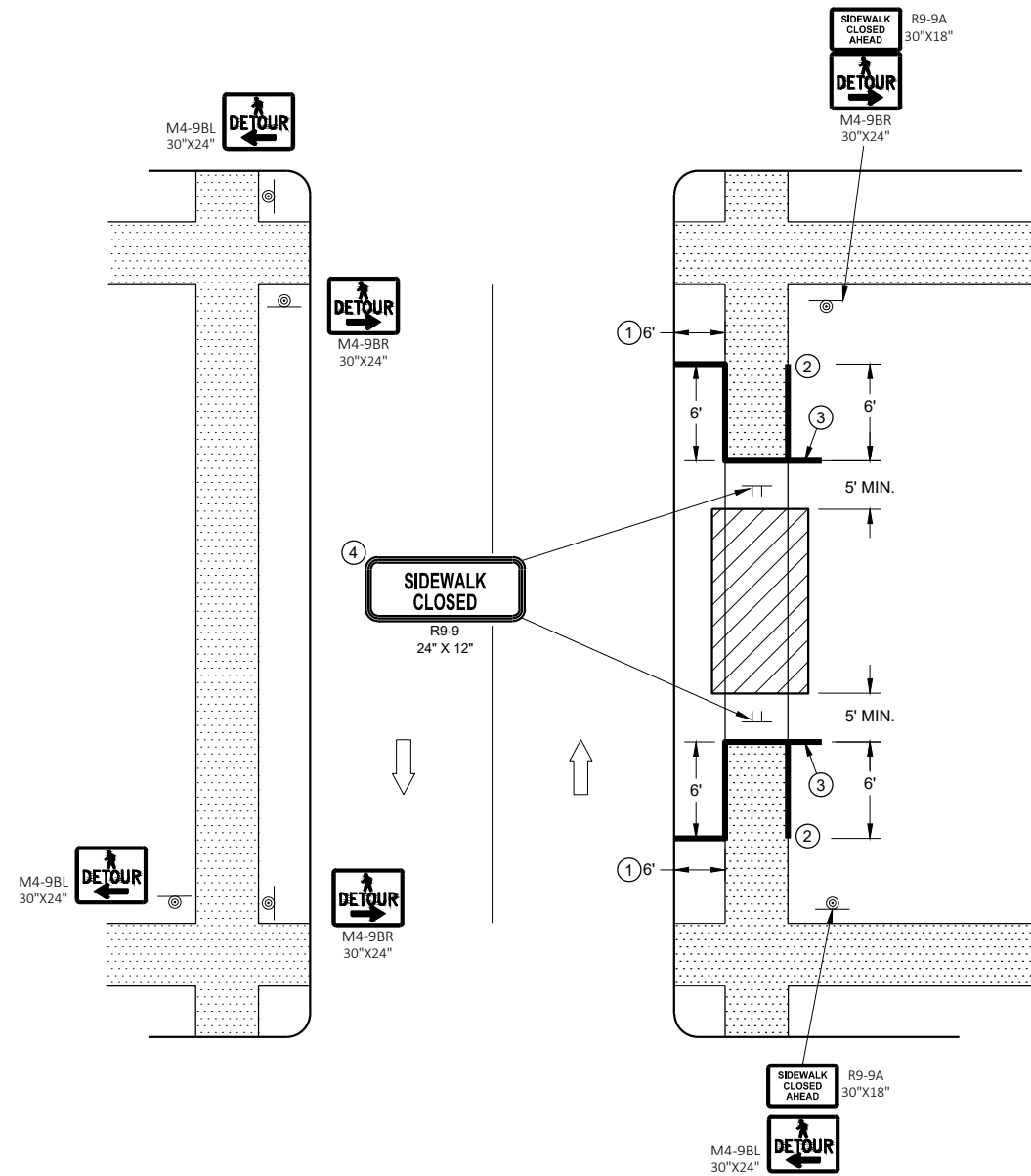

SIDEWALK DETOUR, SIDEWALK ON BOTH SIDES

TRAFFIC CONTROL, PEDESTRIAN ACCOMMODATION
STATE OF WISCONSIN DEPARTMENT OF TRANSPORTATION

GENERAL NOTES

TYPICAL TEMPORARY PEDESTRIAN BARRICADE PANEL IS 6 FEET LONG.

SIGN LAYOUTS SHALL BE IN ACCORDANCE WITH THE WISCONSIN STANDARD SIGN PLATES.

SEE OTHER PEDESTRIAN ACCOMMODATION DETAILS FOR SIGNING AND DEVICES FOR DIFFERENT PEDESTRIAN FACILITIES CLOSURES.

- ① SHOULDER OR LANE CLOSURE ADVANCED WARNING AND PROPER BUFFER SPACE REQUIRED.
- ② 4 FEET MINIMUM, 5 FEET DESIRABLE.
- ③ WHITE 6" TEMPORARY PAVEMENT MARKING.
- ④ IF MINIMUM LANE WIDTHS CAN'T BE ATTAINED, PERPENDICULAR CURB RAMP MAY NEED TO BE UTILIZED.
- ⑤ IF MINIMUM 100' SPACING FROM THE MID-BLOCK CROSSING CANNOT BE ATTAINED BEFORE THE INTERSECTION, REMOVE THIS SIGN ASSEMBLY.
- ⑥ IF TERRACE IS LESS THAN 6 FEET WIDE, OMIT TEMPORARY PEDESTRIAN BARRICADE FROM THE SIDEWALK TO THE CURB.
- ⑦ PLACE BARRICADE CLOSURE SO THAT THE TEMPORARY PEDESTRIAN BARRICADE END IS AT THE LAST OPEN SIDEWALK ACCESS TO RESIDENCES OR BUSINESSES BEFORE THE SIDEWALK CLOSURE.
- ⑧ IF TEMPORARY PEDESTRIAN BARRICADE PANEL IS WIDER THAN THE SIDEWALK WIDTH, THE PORTION OF THE EXCESS PANEL SHOULD EXTEND INTO THE TERRACE.
- ⑨ MOUNTING HEIGHT OF 5 FEET FROM THE SURFACE TO THE BOTTOM OF THE SIGN.

LEGEND

-  TRAFFIC CONTROL DRUM
-  SIGN ON TEMPORARY SUPPORT
-  TEMPORARY CURB RAMP
-  TEMPORARY DETECTABLE WARNING FIELD
-  TEMPORARY PEDESTRIAN SURFACE "A"
-  TEMPORARY PEDESTRIAN SURFACE "B"
-  WORK AREA
-  TEMPORARY PEDESTRIAN BARRICADE
-  DIRECTION OF TRAFFIC

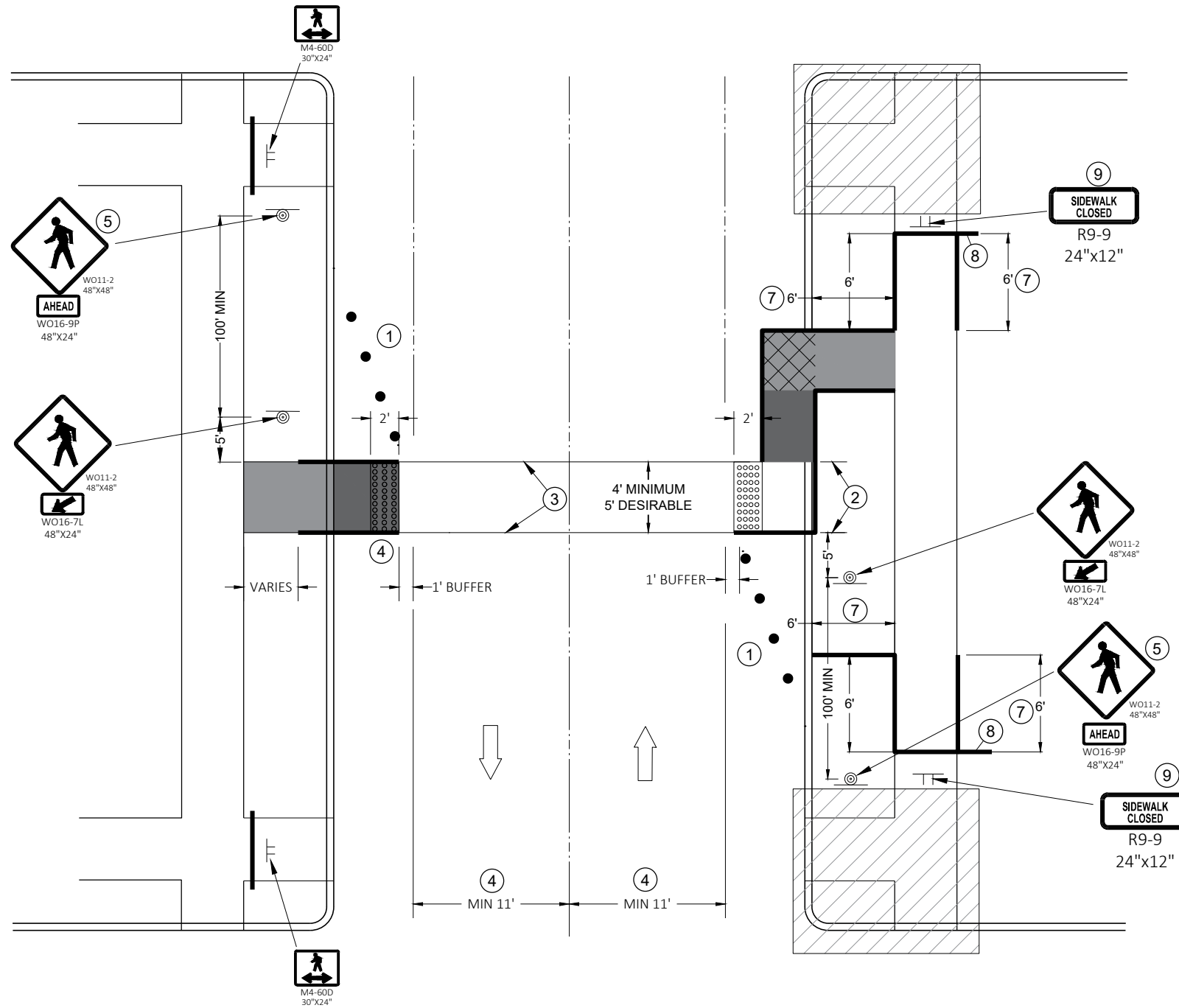







TEMPORARY PEDESTRIAN CROSSING

**TRAFFIC CONTROL,
PEDESTRIAN ACCOMMODATION**

STATE OF WISCONSIN
DEPARTMENT OF TRANSPORTATION

LEGEND

-  TYPE III BARRICADE WITH ATTACHED SIGN
-  SIGN ON PERMANENT SUPPORT
-  TRAFFIC CONTROL DRUM
-  TRAFFIC CONTROL DRUM WITH TYPE "C" STEADY BURN LIGHT
-  TYPE "A" WARNING LIGHT (FLASHING)
-  DIRECTION OF TRAFFIC
-  WORK AREA

POSTED SPEED LIMIT PRIOR TO WORK STARTING (MPH)	ADVANCE WARNING SIGN SPACING (A) FEET	SHIFTING TAPER (L/2) FEET
25	200	60
30	200	90
35	350	120
40	350	160
45	500	270
50	500	300
55	500	330

GENERAL NOTES

THE EXACT NUMBER, LOCATION, AND SPACING OF ALL SIGNS AND DEVICES SHALL BE ADJUSTED TO FIT FIELD CONDITIONS AS APPROVED BY THE ENGINEER.

ALL SIGNS ARE 48"x48" UNLESS OTHERWISE NOTED. IF NECESSARY DUE TO SPACE CONSTRAINTS IN URBAN AREAS, 36"x36" SIGNS MAY BE USED IF APPROVED BY THE REGIONAL TRAFFIC UNIT.

"WO" IS THE SAME AS "W" EXCEPT THE BACKGROUND IS ORANGE.

ANY SIGNS TEMPORARY OR EXISTING, WHICH CONFLICT WITH TRAFFIC CONTROL "IN USE" SHALL BE REMOVED OR COVERED AS NEEDED AND AS APPROVED BY THE ENGINEER.

CHANNELIZING DEVICES PLACED ADJACENT TO WORK AREA SHALL BE PULLED BACK FROM THE TRAVEL LANE WHEN WORK IS NOT IN PROGRESS.

SIGNS THAT WILL BE IN PLACE LESS THAN SEVEN CONTINUOUS DAYS AND NIGHTS MAY BE MOUNTED ON PORTABLE SUPPORTS.

W20-1 AND G20-2A SIGNS ARE NOT REQUIRED IF THE WORK AREA IS WITHIN A LARGER WORK ZONE WHERE THESE SIGNS ARE ALREADY PRESENT. G20-2A SIGNS MAY ALSO BE OMITTED IF DURATION WORK IS LESS THAN SEVEN CONTINUOUS DAYS AND NIGHTS.

PLACE TEMPORARY PAVEMENT MARKING AND PLACE TEMPORARY PAVEMENT LINE IF LANE CLOSURE IS TO BE IN PLACE FOR 4 OR MORE CONTINUOUS DAYS AND NIGHTS.

6

6

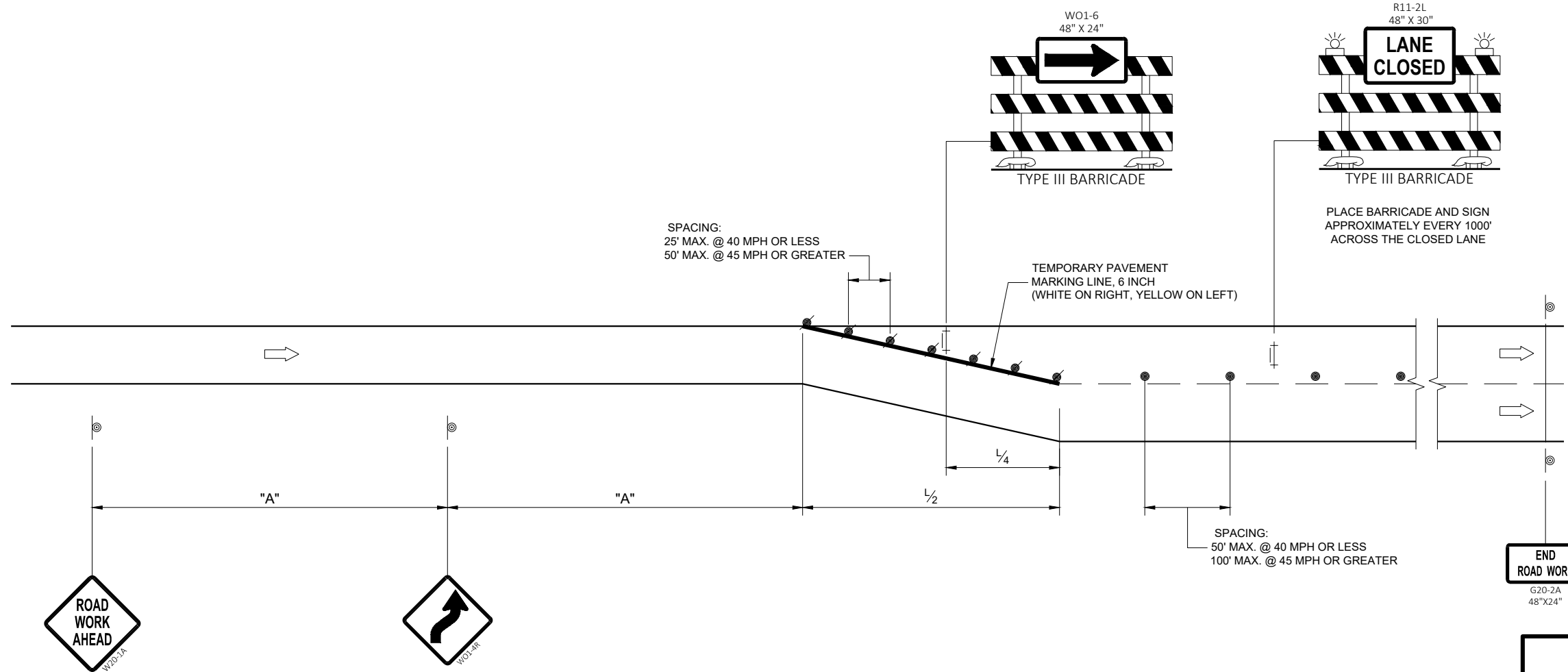

SDD 15D50-03b

SDD 15D50-03b

**TRAFFIC CONTROL,
ADDED LANE CLOSURE
WITH LANE SHIFT**

STATE OF WISCONSIN
DEPARTMENT OF TRANSPORTATION

APPROVED
DATE: May 2023 /S/ Andrew Heidtke
WORK ZONE ENGINEER

FHWA

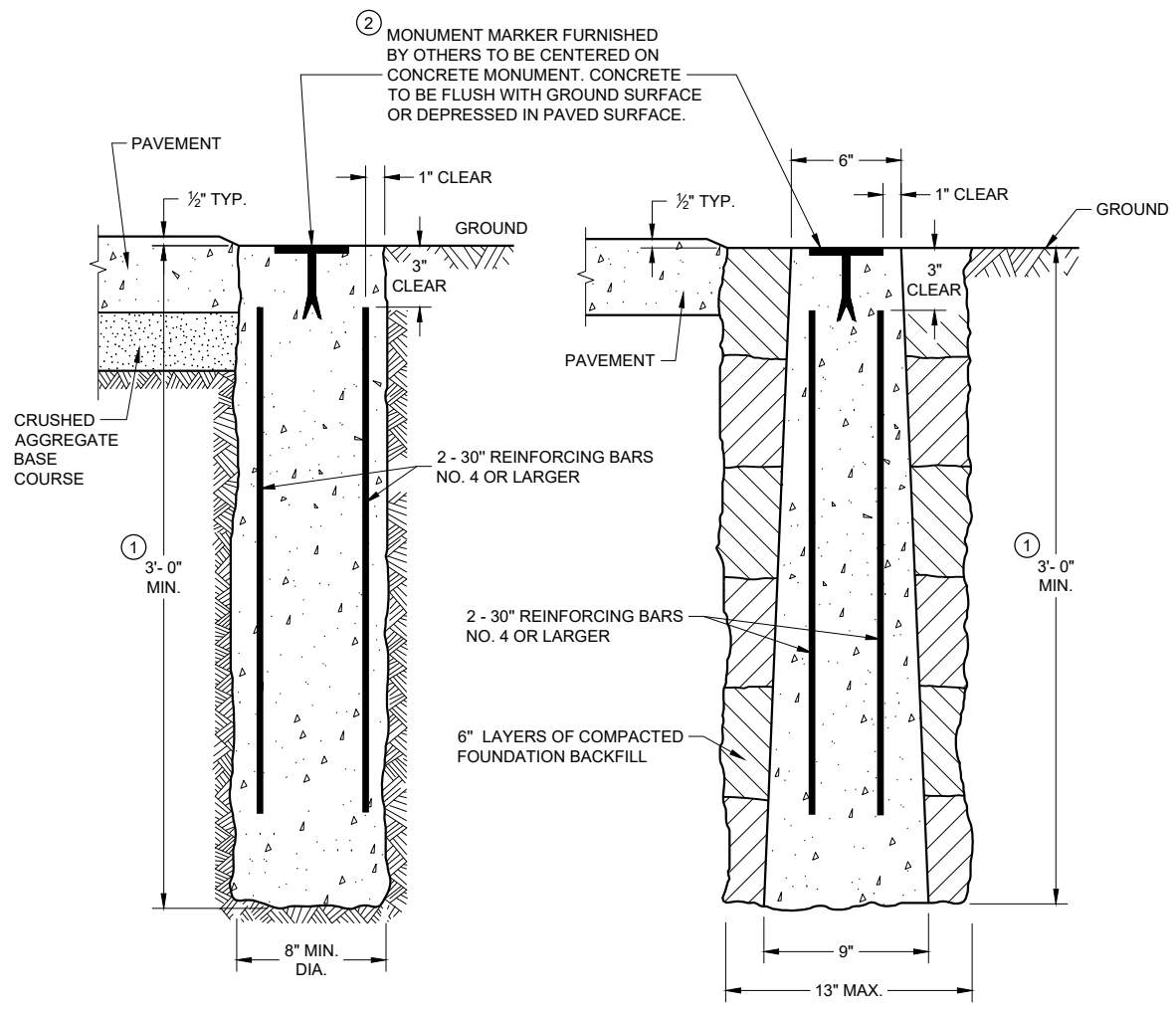

**CAST-IN-PLACE
PRECAST
CONCRETE MONUMENTS
TYPE A**

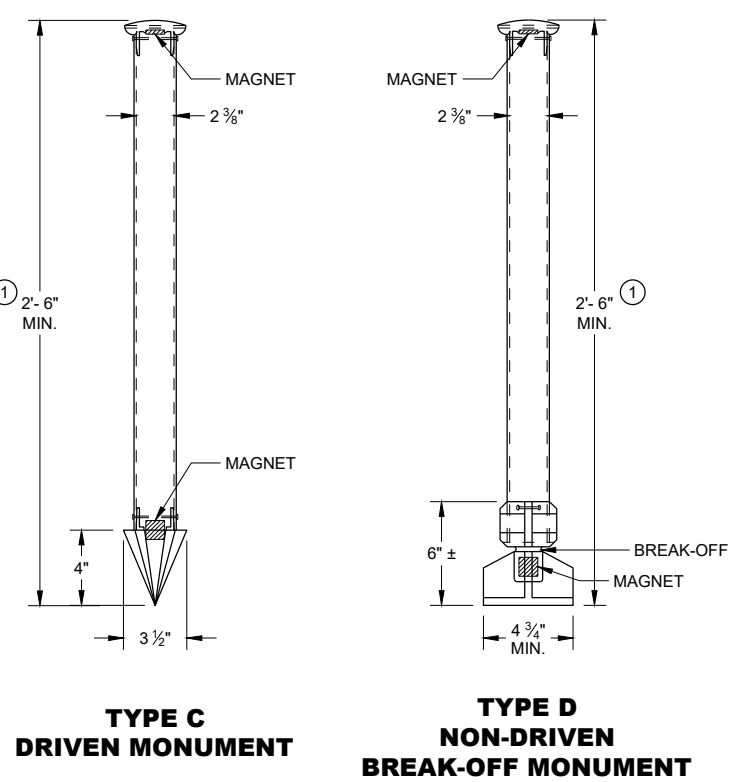

**TYPE C
DRIVEN MONUMENT**
**TYPE D
NON-DRIVEN
BREAK-OFF MONUMENT**
**ALUMINUM MONUMENTS
(INCLUDES MARKER)**

GENERAL NOTES

DETAILS OF CONSTRUCTION, MATERIALS AND WORKMANSHIP NOT SHOWN ON THIS DRAWING SHALL CONFORM TO THE PERTINENT REQUIREMENTS OF THE STANDARD SPECIFICATIONS AND THE APPLICABLE SPECIAL PROVISIONS.

DETAILED DRAWINGS OF PROPOSED ALTERNATE DESIGNS FOR METAL MONUMENTS OR MONUMENT COVERS SHALL BE SUBMITTED TO THE ENGINEER FOR APPROVAL.

PERMANENT MAGNETS SHALL BE INSERTED NEAR THE TOP AND BOTTOM OF ALL ALUMINUM MONUMENTS SO THE MONUMENT CAN EASILY BE DETECTED BY A METAL DETECTOR.

THE CAST IRON MONUMENT COVER SHALL BE A "NON-ROCKING" TYPE. ADJUSTMENT OF THE COVER TO GRADE MAY BE ACCOMPLISHED BY THE USE OF MORTAR AND BRICK, OR BY EITHER PRECAST OR CAST-IN-PLACE REINFORCED CONCRETE GRADE RINGS.

MONUMENTS SHALL BE LOCATED AND PLACED AT THE DIRECTION OF THE ENGINEER.

ALUMINUM MONUMENTS AND MONUMENT COVERS SHALL BE MADE FROM AN ALUMINUM AND MAGNESIUM ALLOY AS DETERMINED BY THE MANUFACTURER.

THE MONUMENT COVERS DETAILED ON THIS DRAWING ARE NOT EQUAL ALTERNATES. MONUMENT COVERS SHALL BE CAST IRON UNLESS ALUMINUM IS SPECIFIED ELSEWHERE IN THE CONTRACT.

MONUMENT SHALL BE CAST-IN-PLACE CONCRETE UNLESS PRECAST CONCRETE OR ALUMINUM MONUMENTS ARE SPECIFIED IN THE CONTRACT OR PERMITTED BY THE ENGINEER.

- ① MINIMUM LENGTH SHALL BE 4'-0" FOR MONUMENTS INSTALLED IN PAVED AREAS.
- ② AN OFFICIAL COUNTY MONUMENT MARKER SUPPLIED BY A COUNTY MAY BE REQUIRED FOR SOME SECTION CORNERS AND WITNESS MONUMENTS INSTEAD OF THIS WISDOT MARKER.

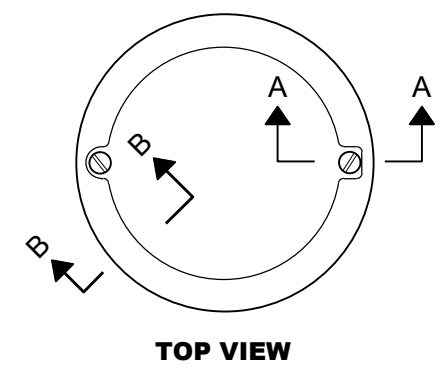

TOP VIEW

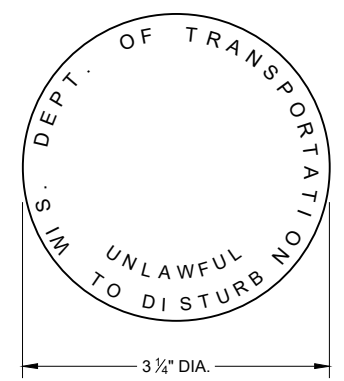

② **WIS DOT MONUMENT MARKER LOGO**
FOR TYPES "A", "C" & "D"

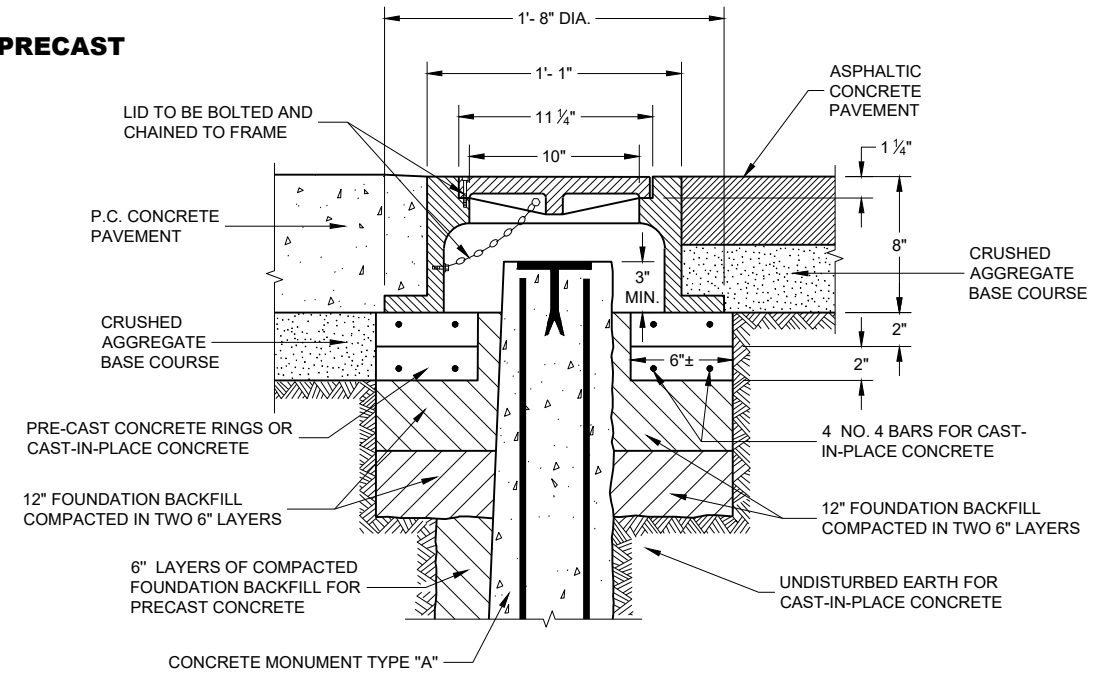

CAST IRON MONUMENT COVER
(APPROXIMATE WEIGHT 95 LBS)

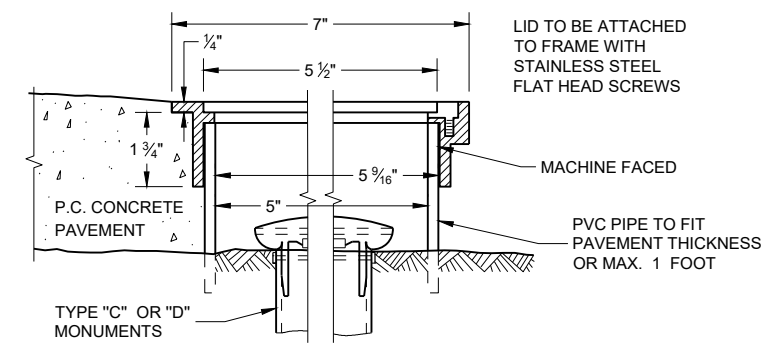

**SECTION B-B SECTION A-A
ALUMINUM MONUMENT COVER**
(APPROXIMATE WEIGHT 2 LBS)
(FOR CONCRETE PAVEMENT ONLY)

LANDMARK REFERENCE MONUMENTS AND COVERS	
STATE OF WISCONSIN DEPARTMENT OF TRANSPORTATION	
APPROVED March 2018 DATE	/s/ Raymond A. Kumapayii CHIEF SURVEYING AND MAPPING ENGINEER
FHWA	

TYPICAL ASSEMBLIES

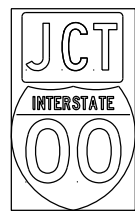

J1-1

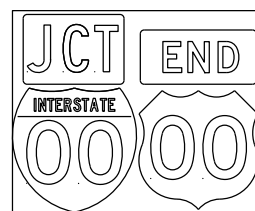

J1-2

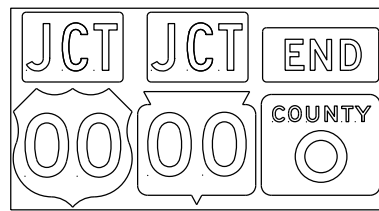

J1-3

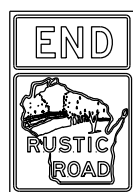

JR1-1

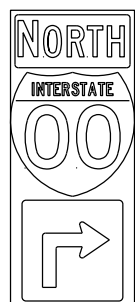

J2-1

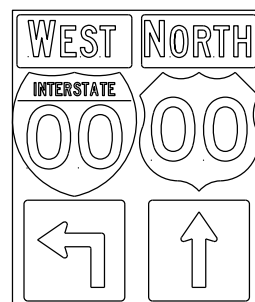

J2-2

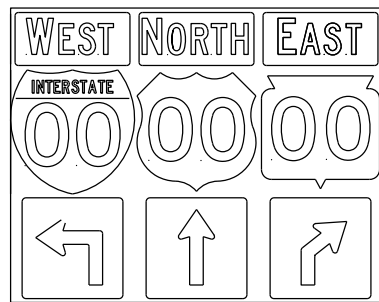

J2-3

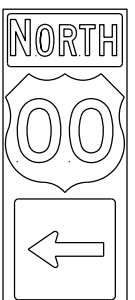

J3-1

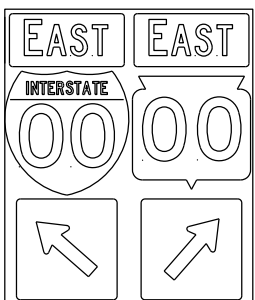

J3-2

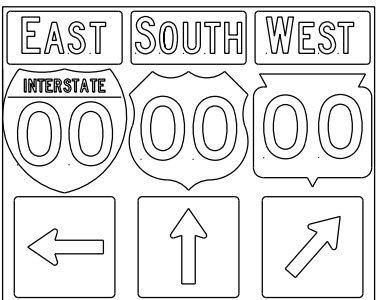

J3-3

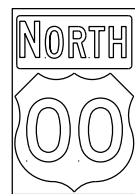

J4-1

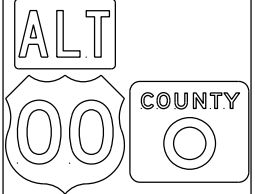

J4-2

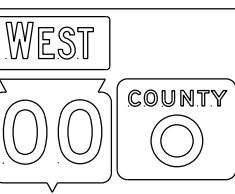

J4-2

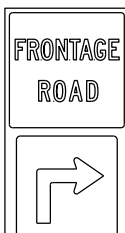

J12-1

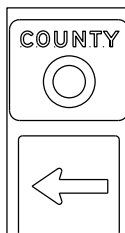

J13-1

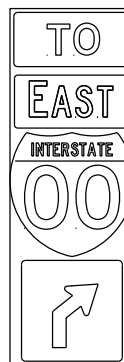

J32-1

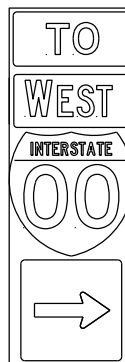

J33-1

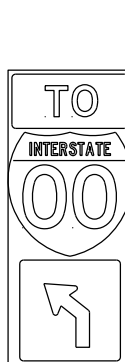

J22-1

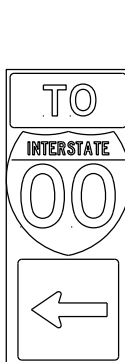

J23-1



JR13-1



JR23-1



JR99-1



JV

(Typical Vertical J-Assembly See Note 10 and 11)

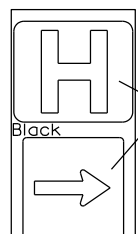

JH-1

Blue Background

blue background with interstate

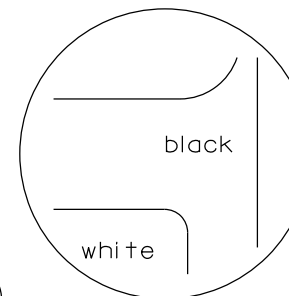
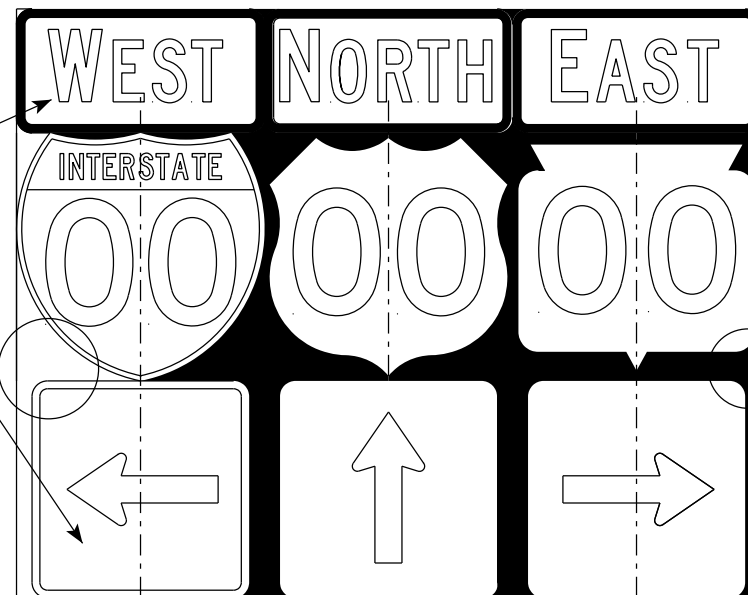
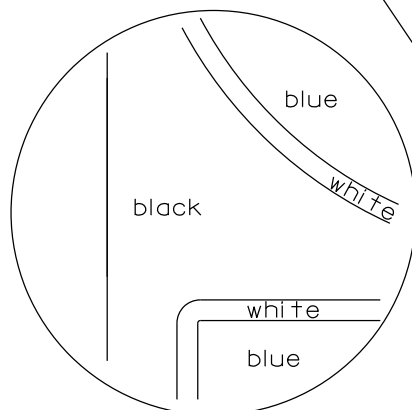

black background

NOTES

- Signs are Type II - Type H Reflective
- Color:
 - Background - Black Non-reflective
 - Message - see Note 5
- Message Series - See Note 5
- Corners shall be square or rounded if base material is plywood. If base material is metal the corners shall be rounded.
- The colors and message spacing on each marker shall be according to the applicable route marker panel specifications.
- Certain marker heads require the component pieces to be the same color. As an example, all the components used with an MI-1 Interstate marker shall be blue.
- Single panel j-assemblies shall only be used with route marker shields that are same size. If the route marker shields are different size use multiple piece component.
- Route assemblies that have 24 inch route shields and have dimensions greater than 48 inches (both vertical and horizontal) shall have one horizontal splice between the arrows and route shields. Vertical splices shall not be used on route assemblies with a horizontal dimension of 144 inches or less. The contractor shall not use more than one vertical joint per sign and the joint shall be between route shields.
- Route assemblies that have 36 inch shields and have dimensions greater than 48 inches (both vertical and horizontal) shall have two horizontal splices. One horizontal splice shall be between the cardinal direction and route shields and the other horizontal splice shall be between the arrows and route shields. Vertical splices shall not be used on route assemblies with a horizontal dimension of 144 or less. The contractor shall not use more than one vertical joint per sign and the joint shall be between route shields.
- All Vertical J Assemblies are given a Sign Code of JV
- For JV Assemblies that have a mixture of Interstate and non Interstate shields, arrows and cardinals shall be white on blue.

ROUTE MARKERS & COMPONENTS IN TYPICAL ASSEMBLIES

WISCONSIN DEPT OF TRANSPORTATION

APPROVED

Matthew R. Rauch
for State Traffic Engineer

DATE 3/18/21

PLATE NO. A2-1S.9

PROJECT NO:

SHEET NO:

E

URBAN AREA

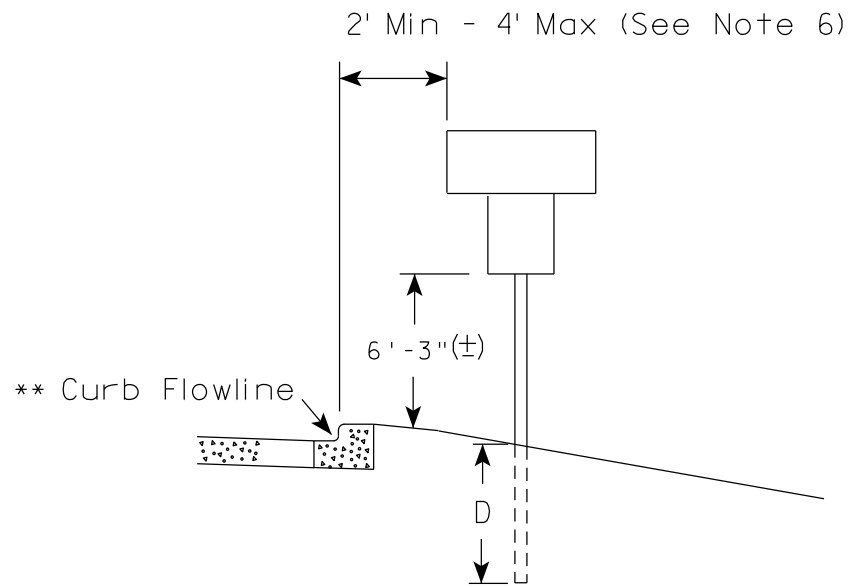
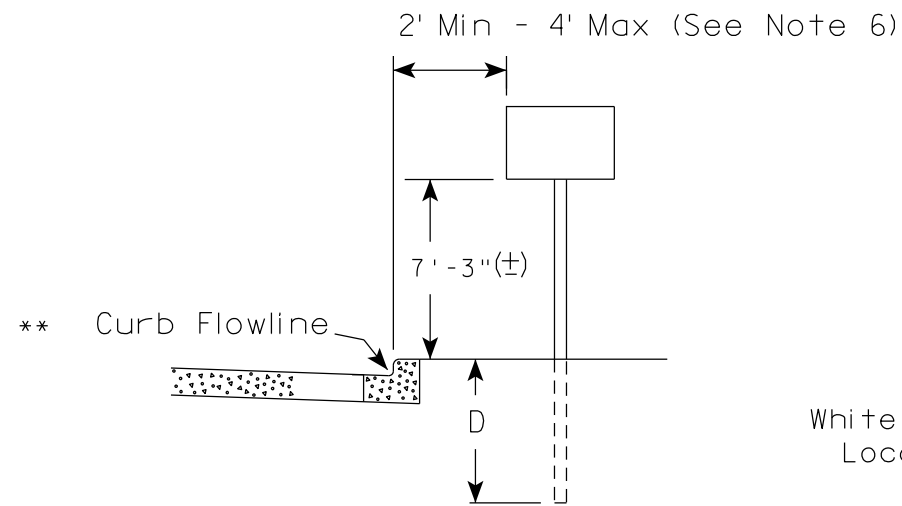

RURAL AREA (See Note 2)

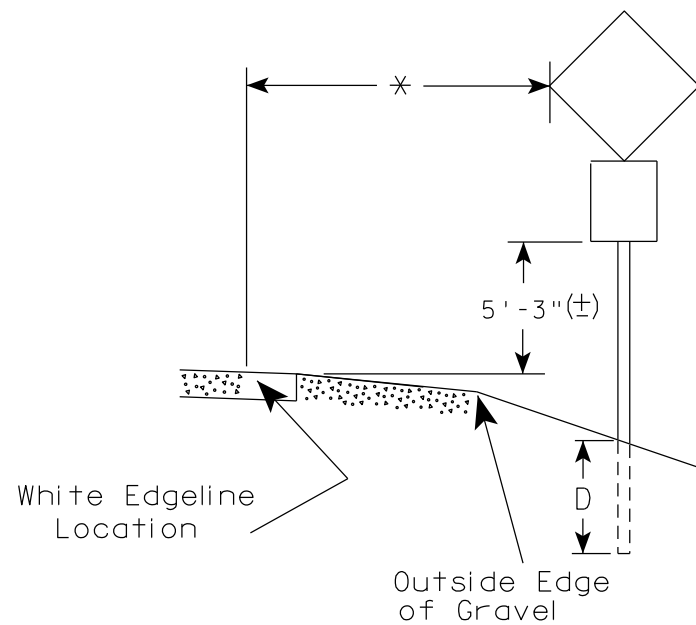
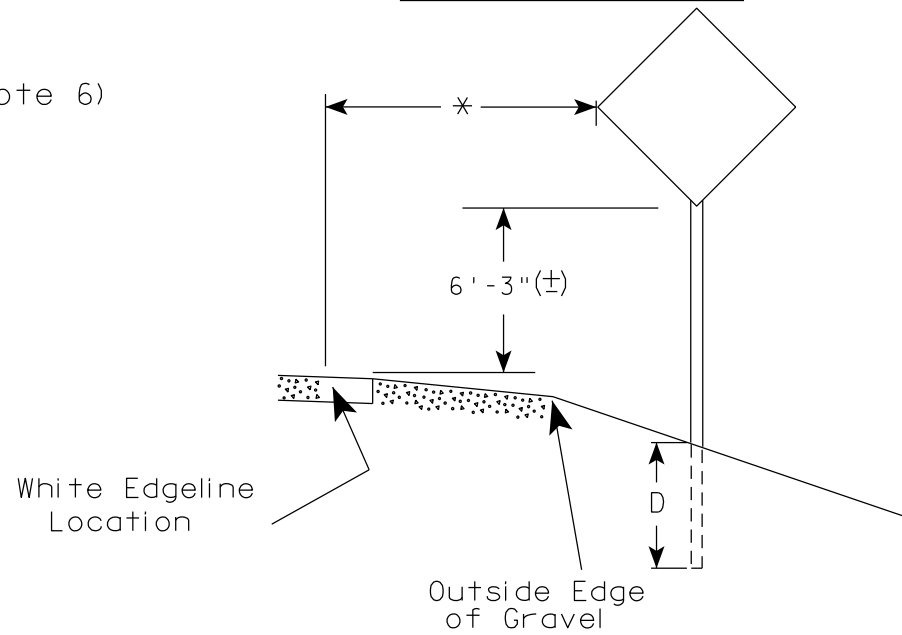

GENERAL NOTES

1. Signs wider than 4 feet or 20 sq.ft or larger, shall be mounted on multiple posts. Refer to plate A4-4.
2. If signs are mounted on or behind barrier wall, see A4-10 sign plate.
The Double Arrow sign (W12-1D) shall be mounted at a height of 2'-3" (±). The Chevron sign (W1-8), Roundabout Chevron panel (R6-4B), Enhanced Reference Markers, Clearance Markers (W5-52), Mile Markers (D10 series), In Road Object Markers (W5-54) & End of Road Markers (W5-56) shall be mounted at a height of 4'-3" (±).
3. For expressways and freeways, mounting height is 7'- 3" (±) or 6'-3" (±) depending upon existence of a sub-sign.
4. Minimum mounting height for signs mounted on traffic signal poles is 5'- 3" (±).
5. Offset distance shall be consistent with existing signs or consistent throughout length of project.
6. The (±) tolerance for mounting height is 3 inches.
7. Folding signs shall be mounted at a height of 5'-3" (±) or as directed by the Engineer.

POST EMBEDMENT DEPTH

Area of Sign Installation (Sq. Ft.)	D (Min)
20 or Less	4'
Greater than 20	5'

* * The existence of curb and gutter does not in itself mandate the vertical clearance illustrated. That height is typically measured where there is sidewalk adjacent to the roadway or parking is permitted. In the absence of sidewalk vertical clearance is measured from the top of the curb. Offset of signs is measured from the flow line.

* 6 feet from edge of a paved shoulder or 12 feet from the edge of pavement (edge line location) or 2 feet from outside edge of gravel, whichever is greater unless directed by project engineer.

TYPICAL INSTALLATION OF PERMANENT TYPE II SIGNS ON SINGLE POSTS

WISCONSIN DEPT OF TRANSPORTATION

APPROVED *Matthew R. Rauch*
for State Traffic Engineer

DATE 5/13/2020 PLATE NO. A4-3.22



ELEVATION VIEW

DETAIL OF WOOD 4 X 6 SIGN POST IN BOX-OUT

- NOTES:**
1. ALL MATERIAL TO BE APPROVED BY ENGINEER PRIOR TO INSTALLATION
 2. SEE SIGN PLATE A4-8 FOR SIGN HARDWARE REQUIREMENTS
 3. 18 INCH X 18 INCH SQUARE BOX-OUTS MAY BE USED FOR INSTALLATIONS IN EXISTING CONCRETE OR ASPHALT LOCATIONS.



ELEVATION VIEW

DETAIL OF STEEL 2 X 2 SIGN POST IN BOX-OUT



PLAN VIEW

FOR NEW CONCRETE/ ASPHALT INSTALLATIONS

**SIGN POST
BOX-OUTS
A4-3B**

WISCONSIN DEPT OF TRANSPORTATION

APPROVED *Matthew R. Rauch*
for State Traffic Engineer

DATE 1/27/14 PLATE NO. A4-3B.1

7

7

GENERAL NOTES

1. For 3 or 4 post installations, individual post spacing shall be greater than 3'-6".
2. See tables below for required number of posts.
3. For expressways and freeways, mounting height is 7'-3" (±) or 6'-3" (±) depending upon existence of sub-sign.
4. The (±) tolerance for mounting height is 3 inches.
5. J-Assemblies are considered to be one sign for mounting height.
6. Offset distance shall be consistent with existing signs or consistent throughout length of project.
7. Folding signs shall be mounted at a height of 5'-3" (±) or as directed by the engineer.
8. The Double Arrow sign (W12-1) shall be mounted at a height of 2'-3" (±). The Chevron sign (W1-8), Roundabout Chevron panel (R6-4B), Clearance Markers (W5-52), Mile Markers (D10 series), In Road Object Markers (W5-54) & End of Road Markers (W5-56) shall be mounted at a height of 4'-3" (±).

URBAN AREA

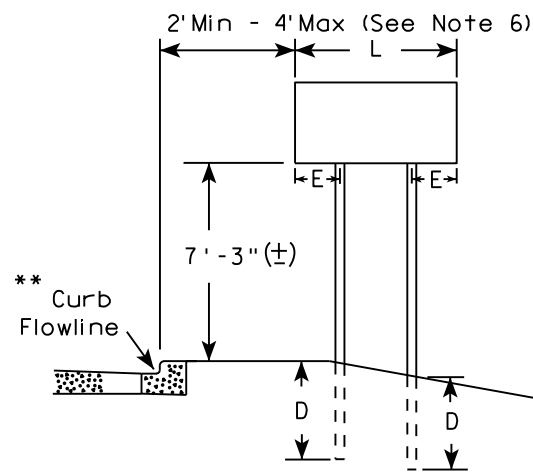

RURAL AREA (See Note 3)

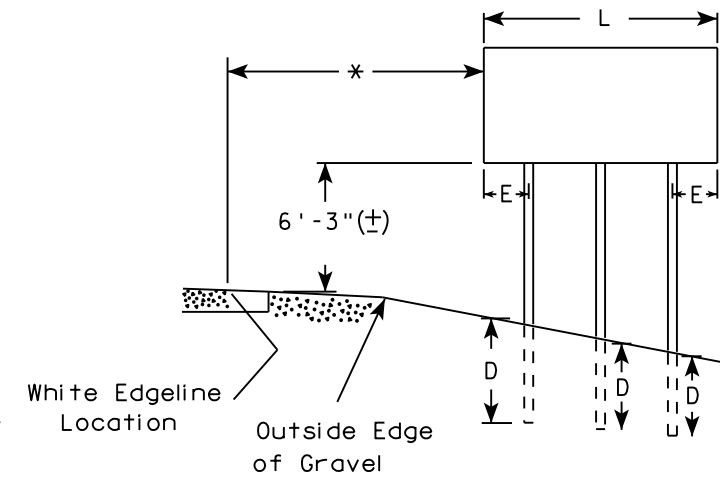
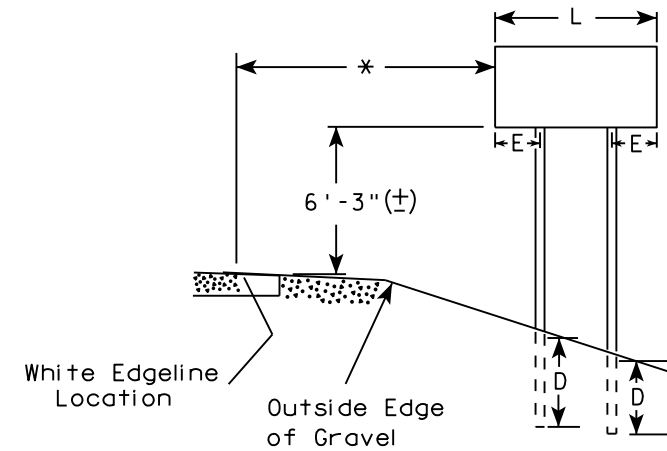

2' Min - 4' Max (See Note 6)

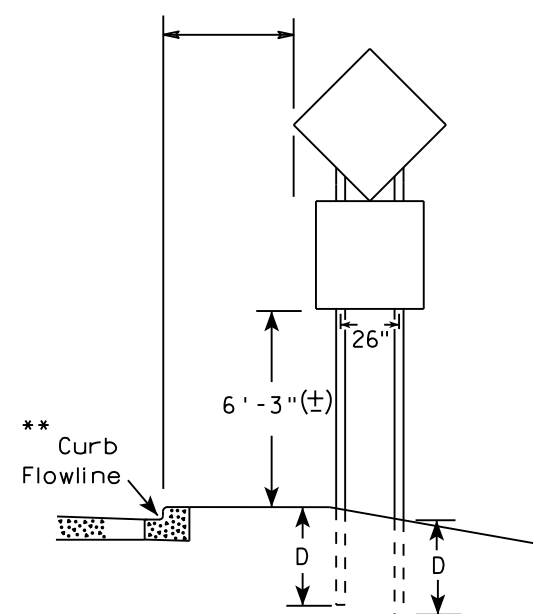

48" DIAMOND WARNING SIGN

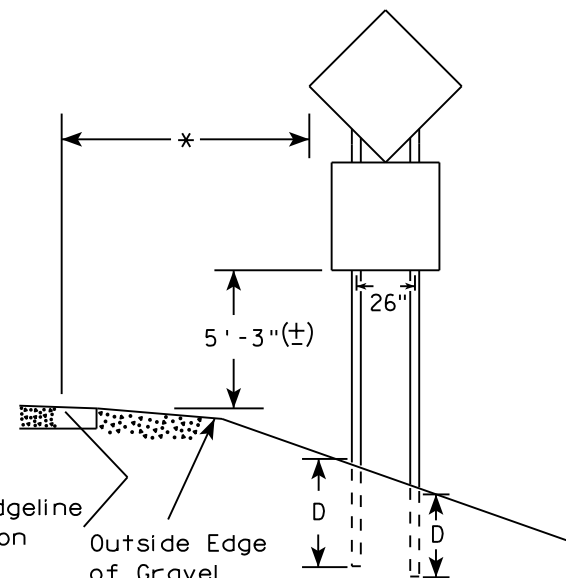

48" DIAMOND WARNING SIGN

* 6 feet from edge of a paved shoulder or 12 feet from the edge of pavement (edge line location) or 2 feet from outside edge of gravel, whichever is greater unless directed by project engineer.

** The existence of curb and gutter does not in itself mandate the vertical clearance illustrated. That height is typically measured where there is sidewalk adjacent to the roadway or parking is permitted. In the absence of sidewalk vertical clearance is measured from the top of the curb. Offset of signs is measured from the flow line.

*** See A4-3 sign plate for signs 4' or less in width and less than 20 S.F. in area.

SIGN SHAPE OTHER THAN DIAMOND (TWO POSTS REQUIRED)	
L	E
Greater than 48" Less than 60"	12"
60" to 108"	L/5

SIGN SHAPE OTHER THAN DIAMOND (THREE POSTS REQUIRED)	
L	E
Greater than 108" to 144"	12"

POST EMBEDMENT DEPTH

Area of Sign Installation (Sq. Ft.)	D (Min)
20 or Less	4'
Greater than 20	5'

TYPICAL INSTALLATION OF TYPE II SIGNS ON MULTIPLE POSTS

WISCONSIN DEPT OF TRANSPORTATION
 APPROVED *Matthew R. Rauch*
 For State Traffic Engineer
 DATE 8/21/17 PLATE NO. A4-4.15

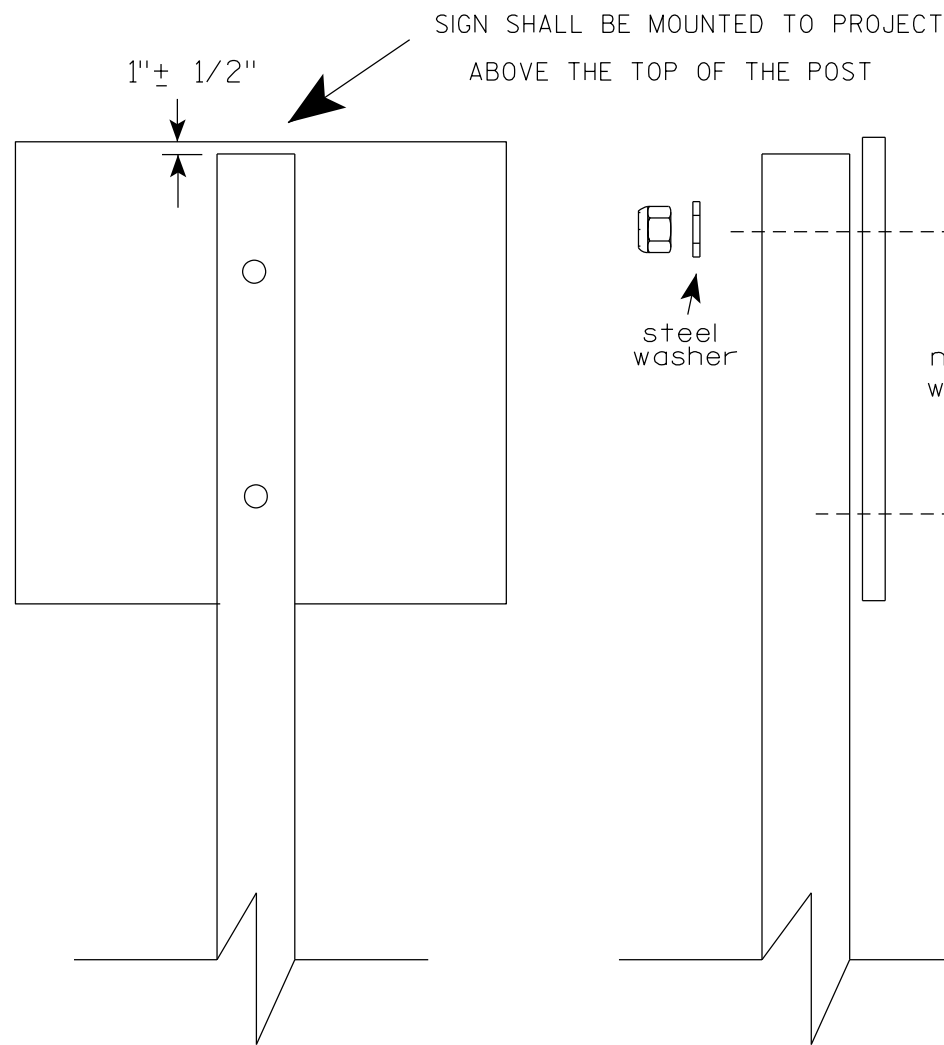

Nuts, bolts and lags used for mounting signs shall have hexagonal heads and shall be either :

- Hot dip galvanized in accordance with ASTM Designation: A 153, Class D, or SC 3
- Electro-galvanized in accordance with ASTM Designation : B 633, TYPE III, SC 3.

Threads on bolts and nuts shall be manufactured with sufficient allowance for the cadmium plate or galvanized coating to permit the nuts to run freely on the bolts.

- STRINGER BOLTING TO ALUMINUM SIGNS (SEE SIGN PLATE A4-18)
- MACHINE BOLTS - $\frac{5}{16}$ " X 1-3/4" Length w/ lock nuts
- WOOD POSTS (4" x 6")
- LAG SCREWS - $\frac{3}{8}$ " X 3" (NO STRINGERS ON BACK OF SIGN)
 - $\frac{3}{8}$ " X 4" (STRINGERS ON BACK OF SIGN)
- SQUARE STEEL POSTS (2" x 2")
- MACHINE BOLTS - $\frac{3}{8}$ " X 3-1/4" Length w/ nuts (NO STRINGER ON BACK OF SIGN)
 - $\frac{3}{8}$ " X 5" Length w/ nuts (STRINGERS ON BACK OF SIGN)
- RIVETS - $\frac{9}{32}$ " (6605-9-6) BULB-TITE, TRI-FOLD, ALUMINUM BODY/MANDREL
- O.D. FLANGE .720-.765 INCH, GRIP RANGE .042-.375 INCH
- WASHERS (ALL POSTS) -
- 1-1/4" O.D. X $\frac{3}{8}$ " I.D. X $\frac{1}{16}$ " STEEL
 - 1-1/4" O.D. X $\frac{3}{8}$ " I.D. X .080 NYLON

* Two different fastening systems are shown for illustration purposes. On any individual sign, either one or the other system shall be used. Actual number of fasteners per sign varies with the sign area, but normally there are two. For a single post installation, all signs greater than 9 sq. ft. require the use of 3 fasteners.

ATTACHMENT OF SIGNS TO POSTS	
WISCONSIN DEPT OF TRANSPORTATION	
APPROVED	<i>Matthew R Rauch</i> For State Traffic Engineer
DATE 4/1/2020	PLATE NO. A4-8.9

**TELESCOPIC TUBING ANCHORS
TWO PIECE SYSTEM**

**2 1/4" SQUARE
12 GAUGE
PERFORATED
GALVANIZED FINISH**

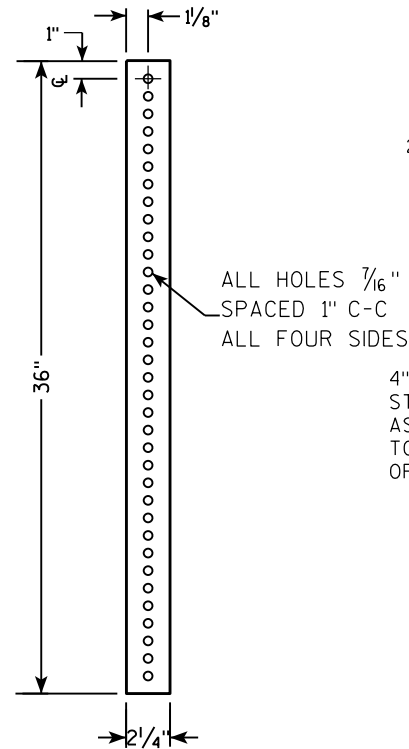

**2 1/2" SQUARE
12 GAUGE
OMNI-DIRECTIONAL
PERFORATED
SOIL STABILIZING SLEEVE
GALVANIZED FINISH**

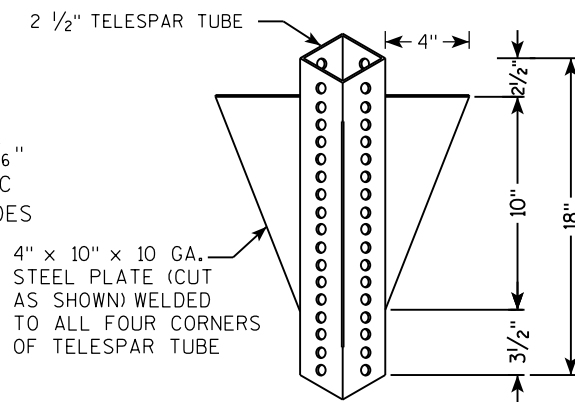

**DETAIL OF TUBULAR STEEL SIGN POST
(IN POURED CONCRETE OR ASPHALT)**

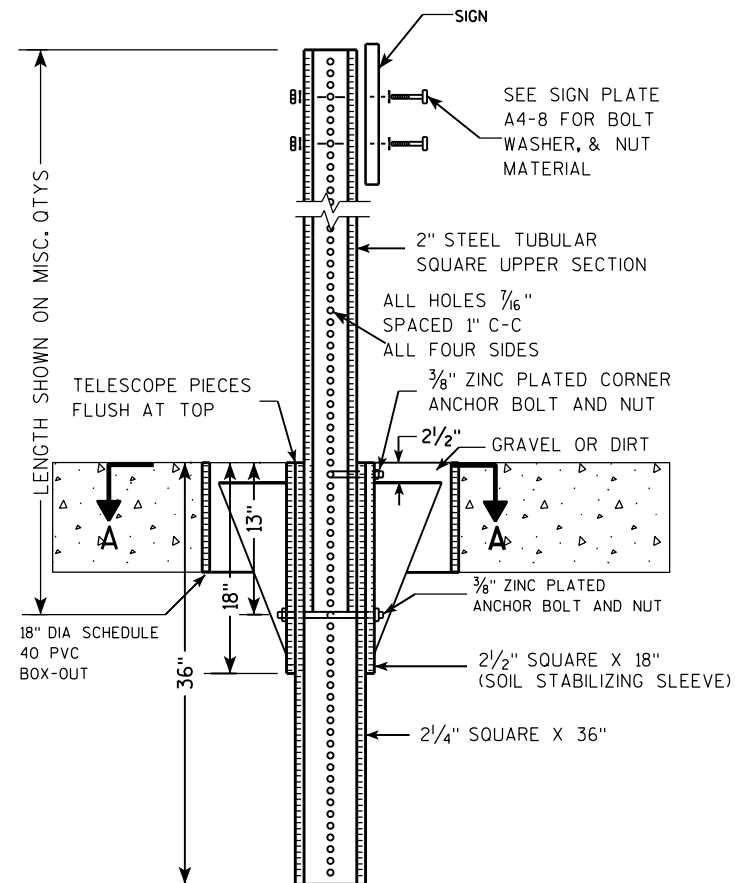

**DETAIL OF TUBULAR STEEL SIGN POST
(IN LOCATIONS OTHER THAN POURED CONCRETE OR ASPHALT)**

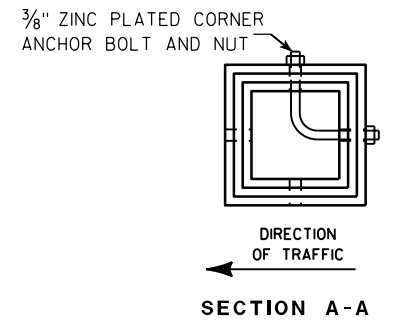
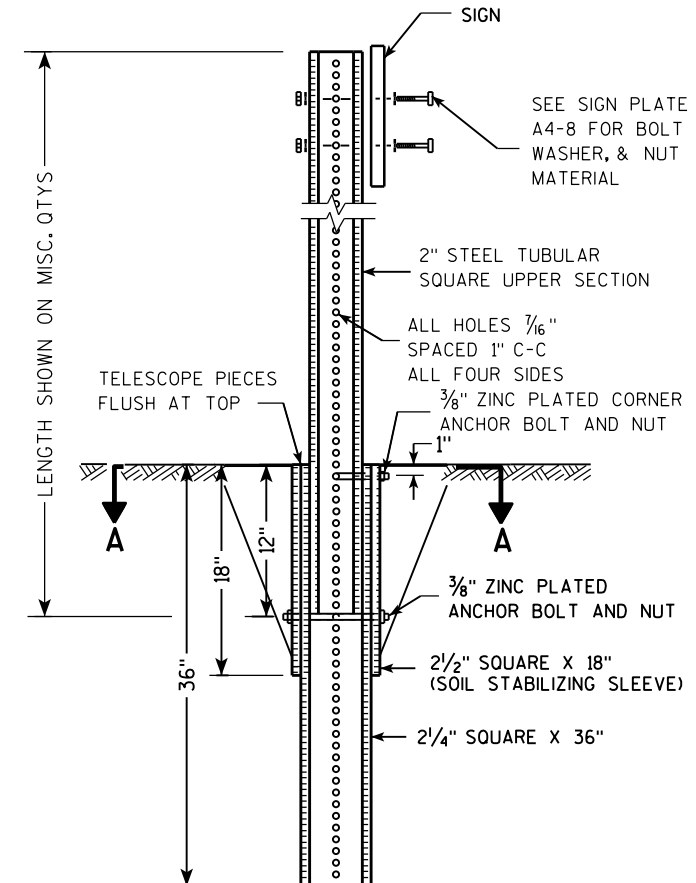

Area of Sign Installation (Sq. Ft.)	Number of Required Posts
9 or less	1
Greater than 9 less than or equal to 18	2
Greater than 18 less than or equal to 27	3

Signs wider than 3 feet or larger than 9 sq. ft shall be mounted on multiple posts (see above table).

**TUBULAR STEEL
SIGN POST
A4-9**

WISCONSIN DEPT OF TRANSPORTATION

APPROVED *Matthew R. Rauch*
for State Traffic Engineer

DATE 2/05/15 PLATE NO. A4-9.9

PROJECT NO:

HWY:

COUNTY:

SHEET NO:

E

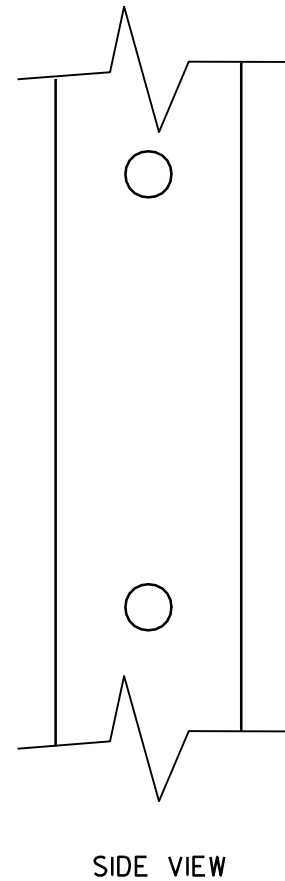
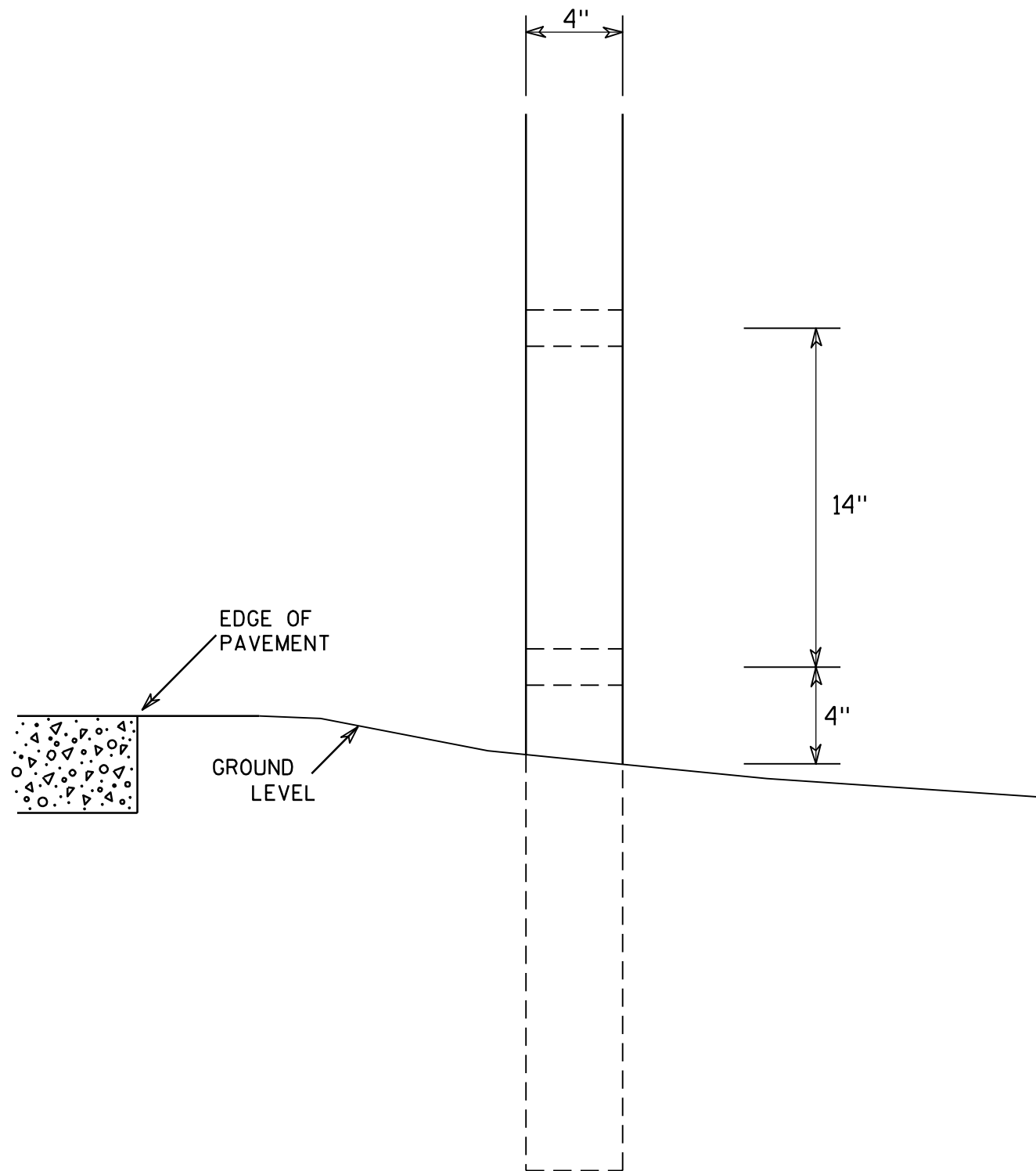

GENERAL NOTES

1. All 4 x 6 Wood Posts shall be modified by having two 1½" diameter holes drilled perpendicular to the roadway centerline.

7

7

4 X 6 WOOD POST MODIFICATIONS	
<i>WISCONSIN DEPT OF TRANSPORTATION</i>	
APPROVED	<i>Chester J Spang</i> for State Traffic Engineer
DATE 3/27/97	PLATE NO. A4-11.2

BANDING

SINGLE SIGN

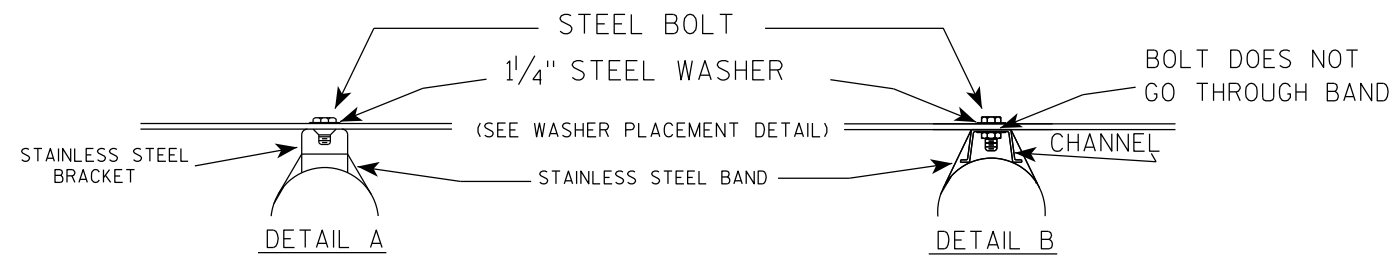
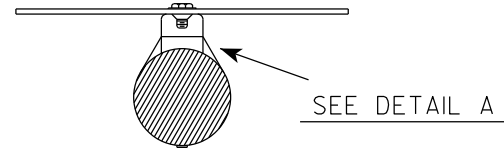
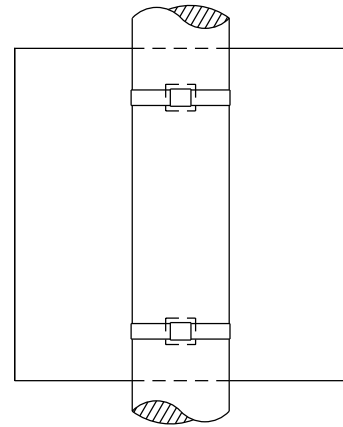

GENERAL NOTES

1. Any sign over 3 feet in width shall use the V-Block banding method. See A5-10 standard plate.
2. Signs 3 feet or greater in height shall have three bracket bands installed. Signs less than 3 feet in height shall have two bracket bands installed.
3. Banding and assembly bracket shall be stainless steel. All bands shall be 3/4" in width and 0.025" thickness.
4. ALL SIGN MOUNTING BOLTS AND WASHERS SHALL BE EITHER:
 - a. Hot dip or mechanically galvanized in accordance with ASTM Designation: A 153, Class D
 - b. Electro-galvanized in accordance with ASTM designation: B 633, Type III, SC 3

"J" ASSEMBLY

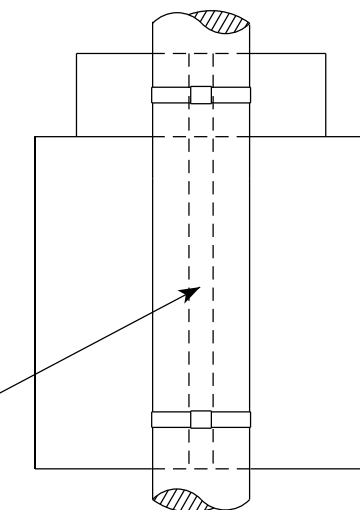

CHANNEL
SEE TYPICAL PANEL
INSTALLATION SHEET



WASHER PLACEMENT

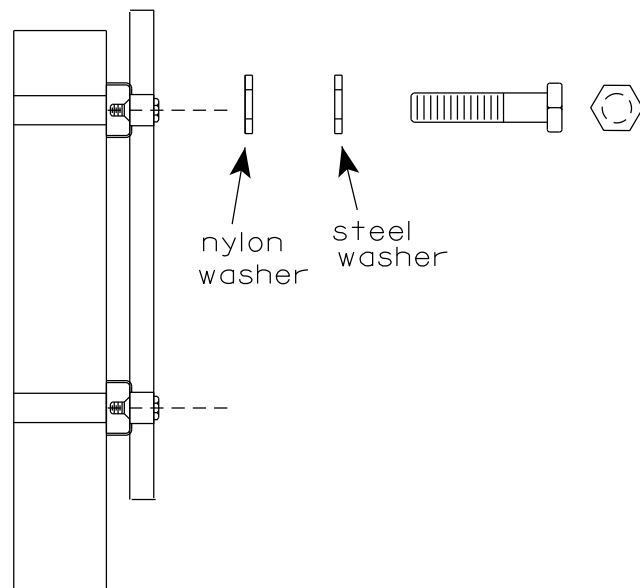

WASHERS (ALL POSTS) -
1-1/4" O.D. X 3/8" I.D. X 1/16" STEEL
1-1/4" O.D. X 3/8" I.D. X .080 NYLON
FOR ALL TYPE H SIGNS

STANDARD SIGN
SIGN BANDING DETAILS

WISCONSIN DEPT OF TRANSPORTATION

APPROVED *Matthew R. Rauch*
for State Traffic Engineer

DATE 6/10/19 PLATE NO. A5-9.4

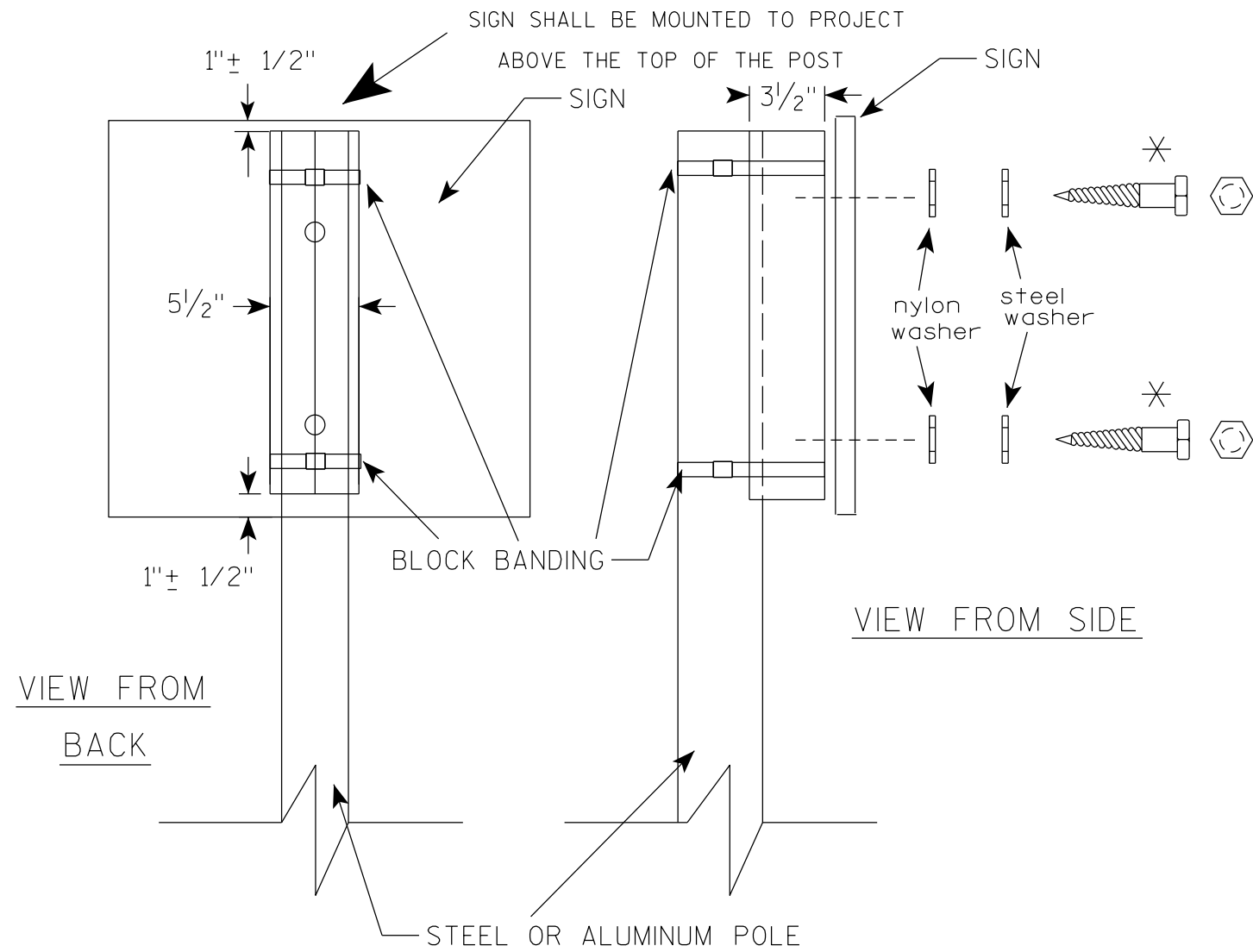

GENERAL NOTES

1. WOOD 4"X6" POST MATERIAL SHALL CONFORM TO 507.2.2 OF THE WISDOT STANDARD SPECIFICATIONS
2. BLOCK BANDING AND CLIPS SHALL BE STAINLESS STEEL, 3/4" WIDTH AND 0.025" THICKNESS
3. SIGNS 3' OR GREATER IN HEIGHT SHALL UTILIZE 3 BLOCK BANDS. SIGNS UNDER 3' IN HEIGHT SHALL UTILIZE 2 BLOCK BANDS
4. ACTUAL NUMBER OF FASTENERS PER SIGN VARIES WITH THE SIGN AREA, BUT NORMALLY THERE ARE TWO. FOR SIGNS GREATER THAN 9 S.F. 3 FASTENERS SHALL BE USED.
5. ALL SIGN MOUNTING BOLTS AND WASHERS SHALL BE EITHER:
 - a. Hot dip or mechanically galvanized in accordance with ASTM Designation: A 153, Class D
 - b. Electro-galvanized in accordance with ASTM Designation : B 633, TYPE III, SC 3
6. ALL BOLTS SHALL HAVE HEXAGONAL HEADS.
7. STEEL WASHERS SHALL BE 1/4" O.D. X 3/8" I.D. X 1/16"
8. NYLON WASHERS SHALL BE 1/4" O.D. X 3/8" I.D. X .080 FOR TYPE H OR TYPE F FACE SIGN

✱ LAG BOLTS SHALL BE 3/8" X 2 1/2"

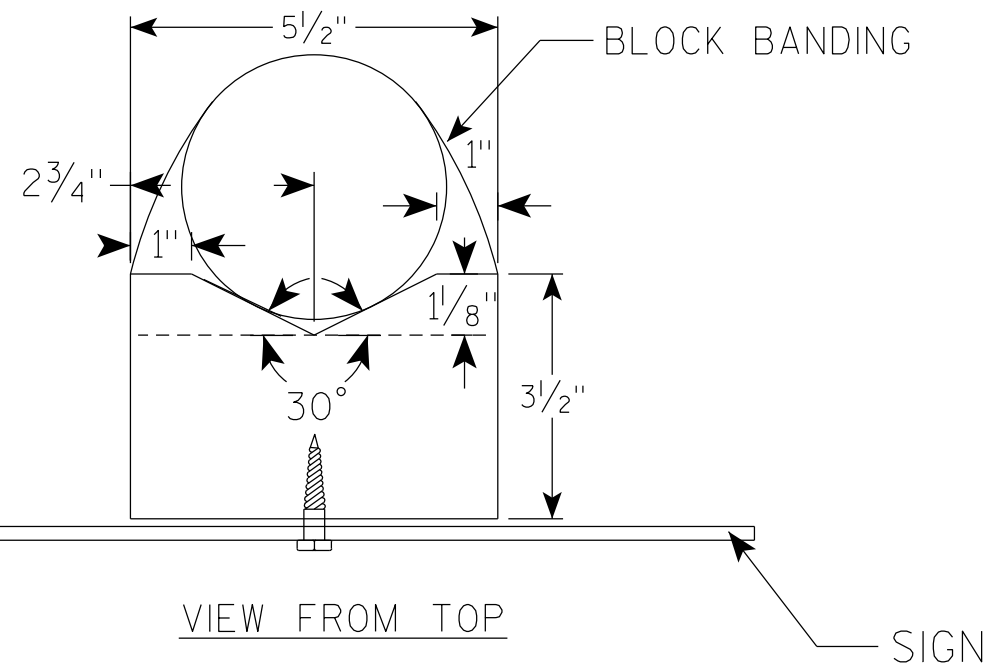

BLOCK BANDING DETAIL
(V-BLOCK OPTION)

WISCONSIN DEPT OF TRANSPORTATION

APPROVED *Matthew R Rauch*
for State Traffic Engineer

DATE 4/19/2022 PLATE NO. A5-10.3

NOTES

1. Sign is Type II - Type F Reflective - reference WIS DOT Standard Specification for HIGHWAY and STRUCTURE CONSTRUCTION latest edition.
2. Color:
Background - Orange
Message - Black
3. Message Series - C
4. Corners may be square or rounded when base material is plywood but borders shall be rounded as shown. When base material is metal, the corners and borders shall be rounded.

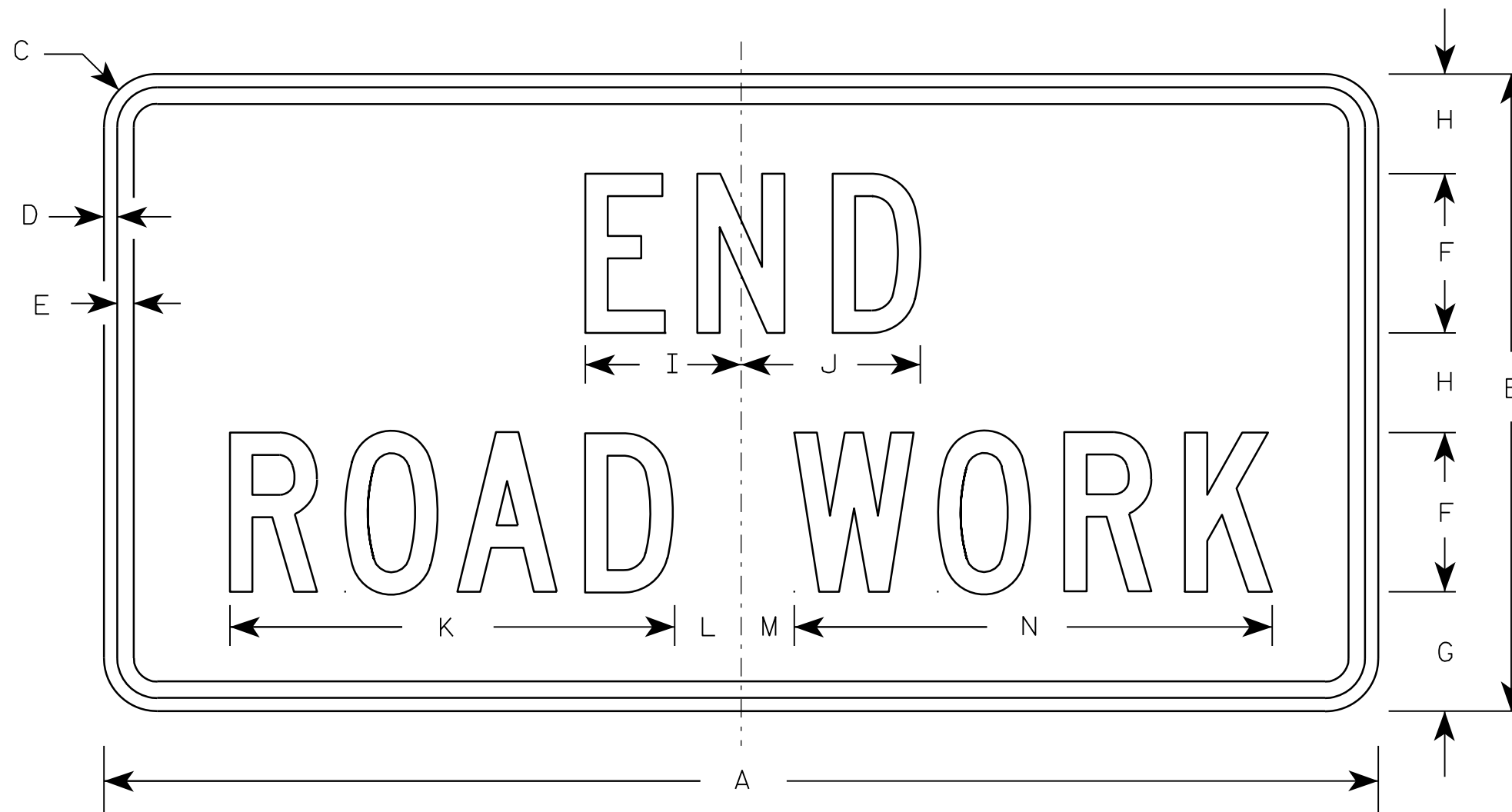

G20-2A

Metric equivalent
for this sign is:

SIZE	
1	900 mm X 450 mm
2	1200 mm X 600 mm
3	1200 mm X 600 mm
4	1200 mm X 600 mm
5	1200 mm X 600 mm

SIZE	A	B	C	D	E	F	G	H	I	J	K	L	M	N	O	P	Q	R	S	T	U	V	W	X	Y	Z	Area sq. ft.	Area sq.
1	36	18	1 1/8	3/8	1/2	4	3 3/4	2 1/2	4 1/8	4 1/8	11 1/8	2	1	12 1/8													4.5	0.41
2	48	24	1 1/2	1/2	5/8	6	4 1/2	3 3/4	5 7/8	6 3/4	16 3/4	2 1/2	1 3/4	18 1/2													8.0	0.72
3	48	24	1 1/2	1/2	5/8	6	4 1/2	3 3/4	5 7/8	6 3/4	16 3/4	2 1/2	1 3/4	18 1/2													8.0	0.72
4	48	24	1 1/2	1/2	5/8	6	4 1/2	3 3/4	5 7/8	6 3/4	16 3/4	2 1/2	1 3/4	18 1/2													8.0	0.72
5	48	24	1 1/2	1/2	5/8	6	4 1/2	3 3/4	5 7/8	6 3/4	16 3/4	2 1/2	1 3/4	18 1/2													8.0	0.72

STANDARD SIGN G20-2A	
WISCONSIN DEPT OF TRANSPORTATION	
APPROVED	<i>Matthew R. Rauch</i> For State Traffic Engineer
DATE 9/30/09	PLATE NO. G20-2A.8

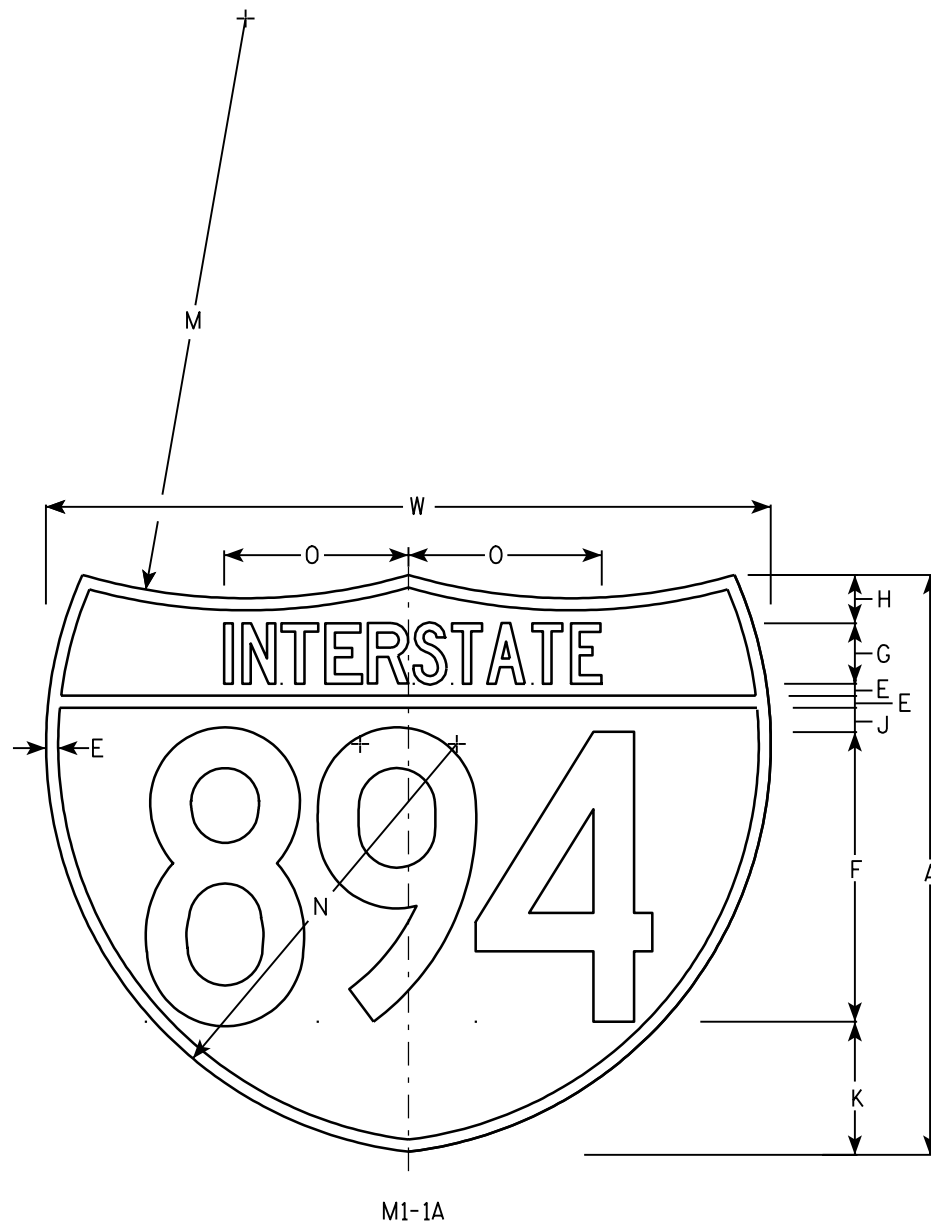
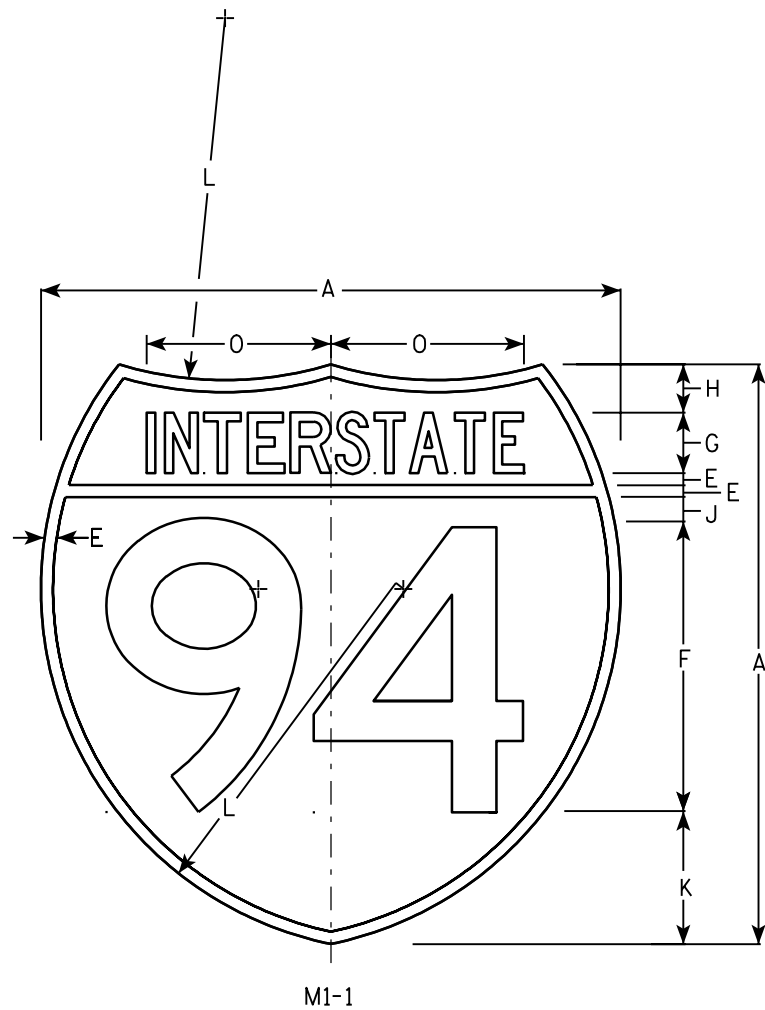

NOTES

1. Sign is Type II - See Note 6 - reference WIS DOT Standard Specification for HIGHWAY and STRUCTURE CONSTRUCTION latest edition.
2. Color:
Background - Top Red - Bottom Blue (See Note 6)
Message - White - See Note 6
3. Message Series - See note 5
4. Substitute appropriate numerals & adjust spacing as per plate A10-1.
5. M1-1 - Numerals - D
Interstate - C
M1-1A - All copy - C
6. Permanent Signs
Message - Type H Reflective
Detour or other temporary signs
Background - Reflective
Message - Reflective

Metric equivalent for these signs are:

SIZE	M1-1	SIZE	M1-1A
1			
2	600 mm X 600 mm	2	600 mm X 750 mm
3	900 mm X 900 mm	3	900 mm X 1125 mm
4	900 mm X 900 mm	4	900 mm X 1125 mm
5	900 mm X 900 mm	5	900 mm X 1125 mm

SIZE	A	B	C	D	E	F	G	H	I	J	K	L	M	N	O	P	Q	R	S	T	U	V	W	X	Y	M1-1 Area sq. ft.	M1-1A Area sq. ft.	M1-1 Area m ²	M1-1A Area m ²
1																													
2	24				1/2	12	2 1/2	2		1	5 1/2	15	24	17	7 7/8									30		3.13	3.91	.36	.46
3	36				3/4	18	3 3/4	3		1 1/2	8 1/4	22 1/2	36	25 1/2	11 3/4									45		7.03	8.79	.81	1.05
4	36				3/4	18	3 3/4	3		1 1/2	8 1/4	22 1/2	36	25 1/2	11 3/4									45		7.03	8.79	.81	1.05
5	36				3/4	18	3 3/4	3		1 1/2	8 1/4	22 1/2	36	25 1/2	11 3/4									45		7.03	8.79	.81	1.05

INTERSTATE ROUTE MARKER
M1-1 FOR ASSEMBLIES

WISCONSIN DEPT OF TRANSPORTATION

APPROVED *Matthew R Rauch*
for State Traffic Engineer

DATE 08/23/05 PLATE NO. M1-1.8

PROJECT NO: _____ HWY: _____ COUNTY: _____ SHEET NO: **E**

NOTES

- All Signs Type II - Type H
- Color:
 - Background - See note 5
 - Message - See note 5
- Message Series - C
- Corners may be square or rounded when base material is plywood but borders shall be rounded as shown. When base material is metal, the corners and borders shall be rounded.
- M3-1 thru M3-4 Background - White
 Message - Black
 MB3-1 thru MB3-4 Background - Blue
 Message - White
 MK3-1 thru MK3-4 Background - Green
 Message - White
 MM3-1 thru MM3-4 Background - White
 Message - Green
 MN3-1 thru MN3-4 Background - Brown
 Message - White
 MP3-1 thru MP3-4 Background - White
 Message - Blue
- Note the first letter of each direction is larger than the remainder of the message.

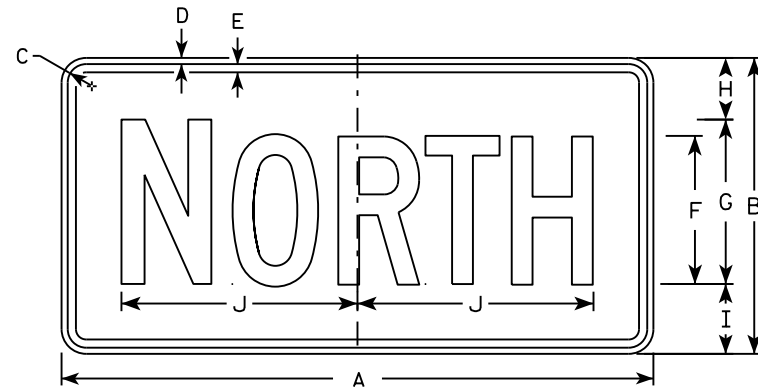

M3-1
MM3-1
MP3-1

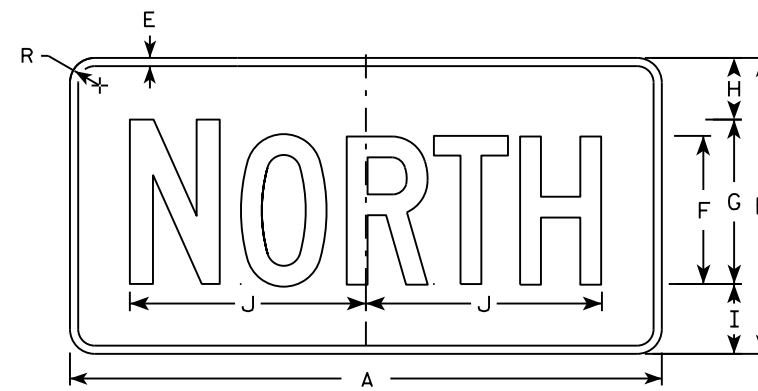

MB3-1
MK3-1
MN3-1

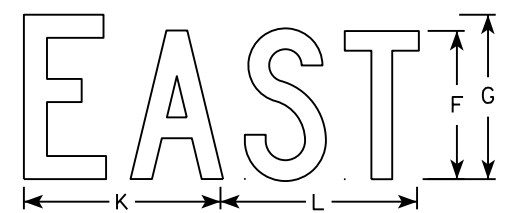

M3-2
MM3-2
MP3-2

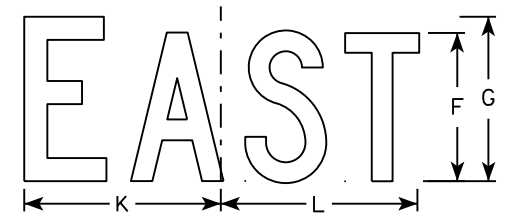

MB3-2
MK3-2
MN3-2

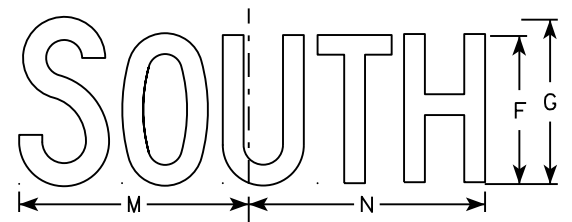

M3-3
MM3-3
MP3-3

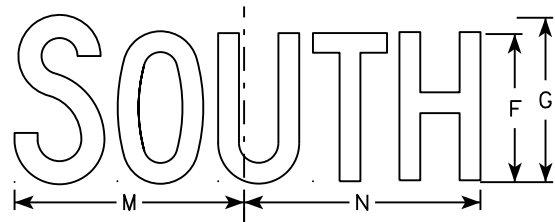

MB3-3
MK3-3
MN3-3

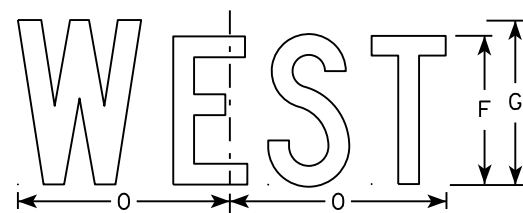

M3-4
MM3-4
MP3-4

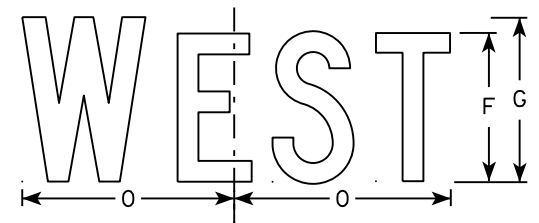

MB3-4
MK3-4
MN3-4

7

SIZE	A	B	C	D	E	F	G	H	I	J	K	L	M	N	O	P	Q	R	S	T	U	V	W	X	Y	Z	Area sq. ft.
1																											
2	24	12	1 1/8	3/8	3/8	6	7	2 1/4	2 3/4	10 1/4	7 7/8	8 3/8	10 1/4	9 3/4	8 3/4			1 1/2									2.00
3	36	18	1 1/8	3/8	1/2	9	10	3 3/4	4 1/4	14 3/8	12	12 1/8	14	14 1/8	13			1 1/2									4.5
4	36	18	1 1/8	3/8	1/2	9	10	3 3/4	4 1/4	14 3/8	12	12 1/8	14	14 1/8	13			1 1/2									4.5
5	36	18	1 1/8	3/8	1/2	9	10	3 3/4	4 1/4	14 3/8	12	12 1/8	14	14 1/8	13			1 1/2									4.5

STANDARD SIGNS
M3-1 thru M3-4
SERIES

WISCONSIN DEPT OF TRANSPORTATION

APPROVED *Matthew R. Rauch*
for State Traffic Engineer

DATE 10/15/15 PLATE NO. M3-1.14

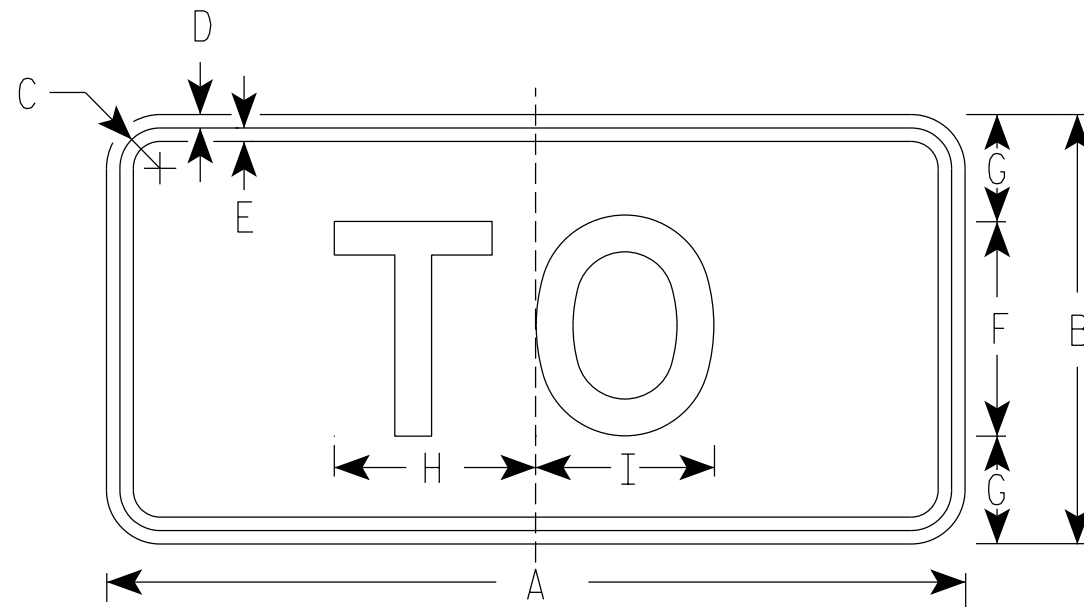

M4-5
MM4-5
MP4-5
M04-5

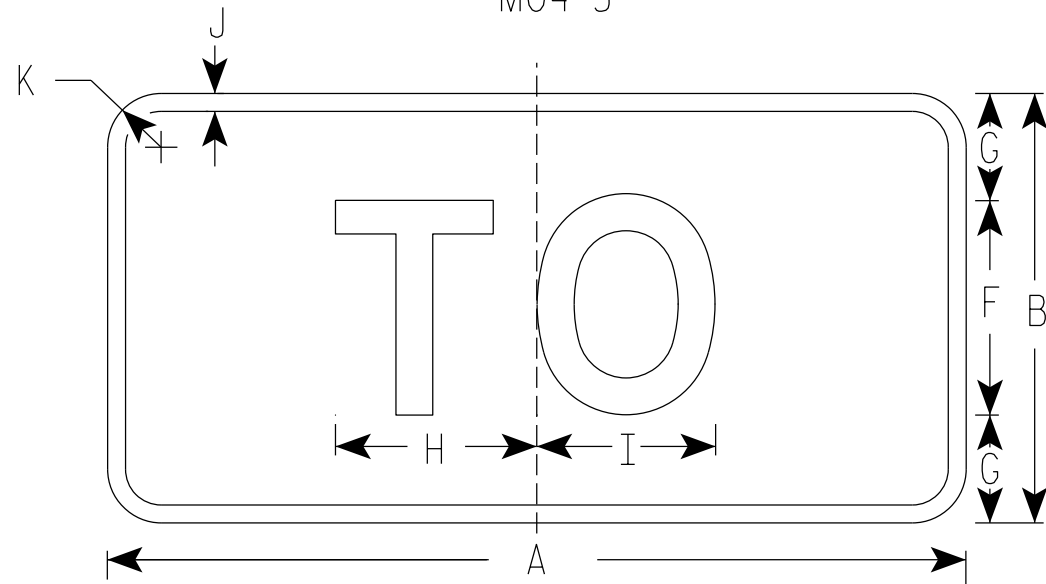

MB4-5
MK4-5
MN4-5

NOTES

1. Sign is Type II - Type H Reflective
2. Color:
Background - See note 5
Message - See note 5
3. Message Series - E
4. Corners may be square or rounded when base material is plywood but borders shall be rounded as shown. When base material is metal, the corners and borders shall be rounded.
5. M4-5 Background - White
Message - Black
MB4-5 Background - Blue
Message - White
MK4-5 Background - Green
Message - White
MM4-5 Background - White
Message - Green
MN4-5 Background - Brown
Message - White
MP4-5 Background - White
Message - Blue
M04-5 Background - Orange Type F Reflective
Message - Black

7

7

SIZE	A	B	C	D	E	F	G	H	I	J	K	L	M	N	O	P	Q	R	S	T	U	V	W	X	Y	Z	Area sq. ft.
1																											
2	24	12	1 1/8	3/8	3/8	6	3	5 3/8	5 1/4	1/2	1 1/2																2.00
3	36	18	1 3/8	3/8	1/2	9	4 1/2	8 1/4	8 3/8	1/2	1 1/2																4.5
4	36	18	1 3/8	3/8	1/2	9	4 1/2	8 1/4	8 3/8	1/2	1 1/2																4.5
5	36	18	1 3/8	3/8	1/2	9	4 1/2	8 1/4	8 3/8	1/2	1 1/2																4.5

STANDARD SIGN
M4-5

WISCONSIN DEPT OF TRANSPORTATION

APPROVED *Matthew R. Rauch*
State Traffic Engineer

DATE 03/7/19 PLATE NO. M4-5.9

PROJECT NO: _____ HWY: _____ COUNTY: _____ SHEET NO: **E**

NOTES

1. Sign is Type II - Type F Reflective - reference WIS DOT Standard Specification for HIGHWAY and STRUCTURE CONSTRUCTION latest edition.
2. Color:
Background - Orange
Message - Black
3. Message Series - B
4. Corners may be square or rounded when base material is plywood but borders shall be rounded as shown. When base material is metal, the corners and borders shall be rounded.

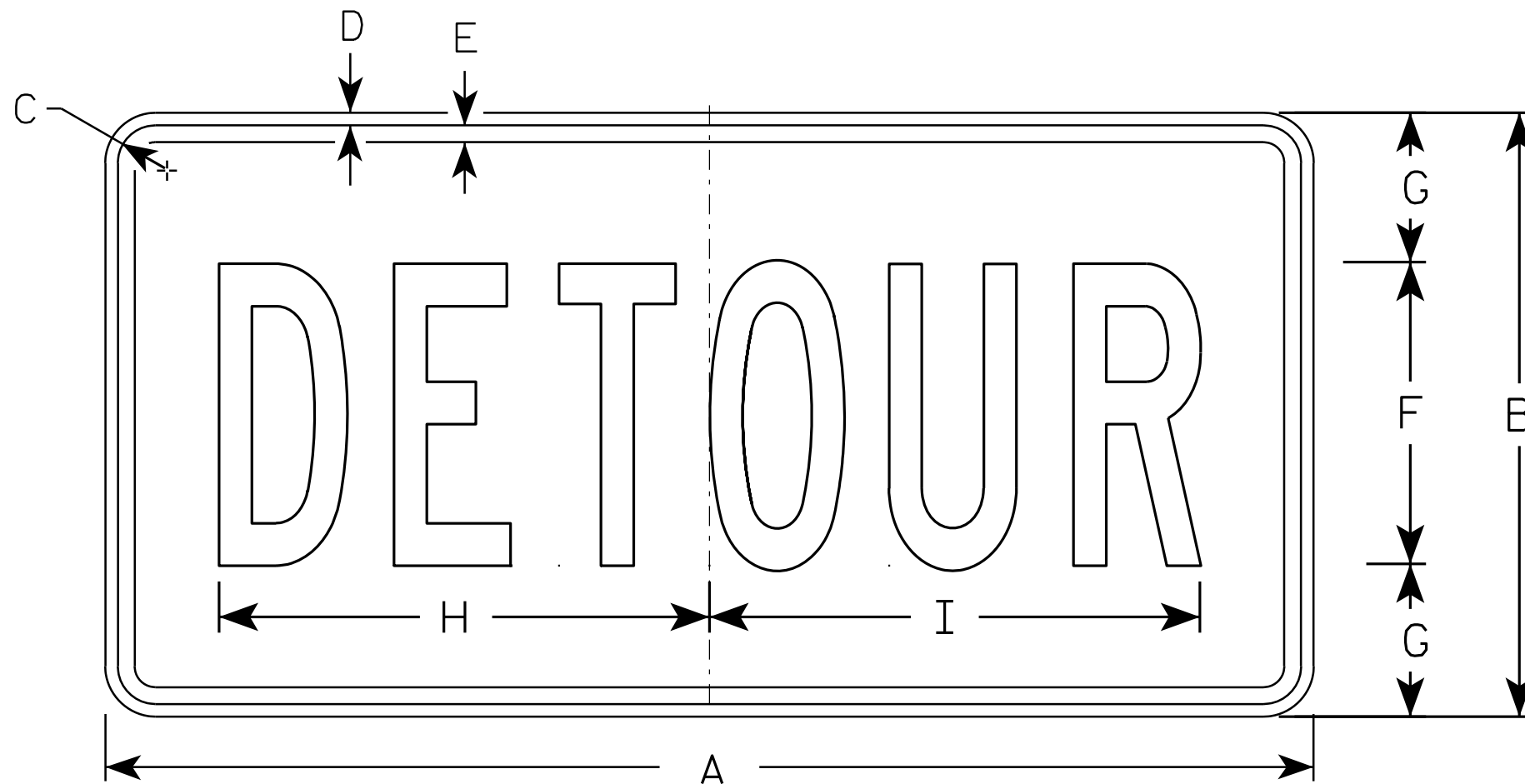

M4-8

7

7

SIZE	A	B	C	D	E	F	G	H	I	J	K	L	M	N	O	P	Q	R	S	T	U	V	W	X	Y	Z	Area sq. ft.
1																											
2	24	12	1 1/8	3/8	3/8	6	3	10	10 1/4																		2.0
3	36	18	1 1/8	3/8	1/2	9	4 1/2	14 5/8	14 1/2																		4.5
4																											
5																											

STANDARD SIGN
M4-8

WISCONSIN DEPT OF TRANSPORTATION

APPROVED *Matthew R. Rauch*
for State Traffic Engineer

DATE 11/10/10 PLATE NO. M4-8.2

PROJECT NO: _____ HWY: _____ COUNTY: _____ SHEET NO: **E**

NOTES

1. Sign is Type II - Type F Reflective - reference WIS DOT Standard Specification for HIGHWAY and STRUCTURE CONSTRUCTION latest edition.
2. Color:
Background - Orange
Message - Black
3. Message Series - B
4. Corners may be square or rounded when base material is plywood but borders shall be rounded as shown. When base material is metal, the corners and borders shall be rounded.

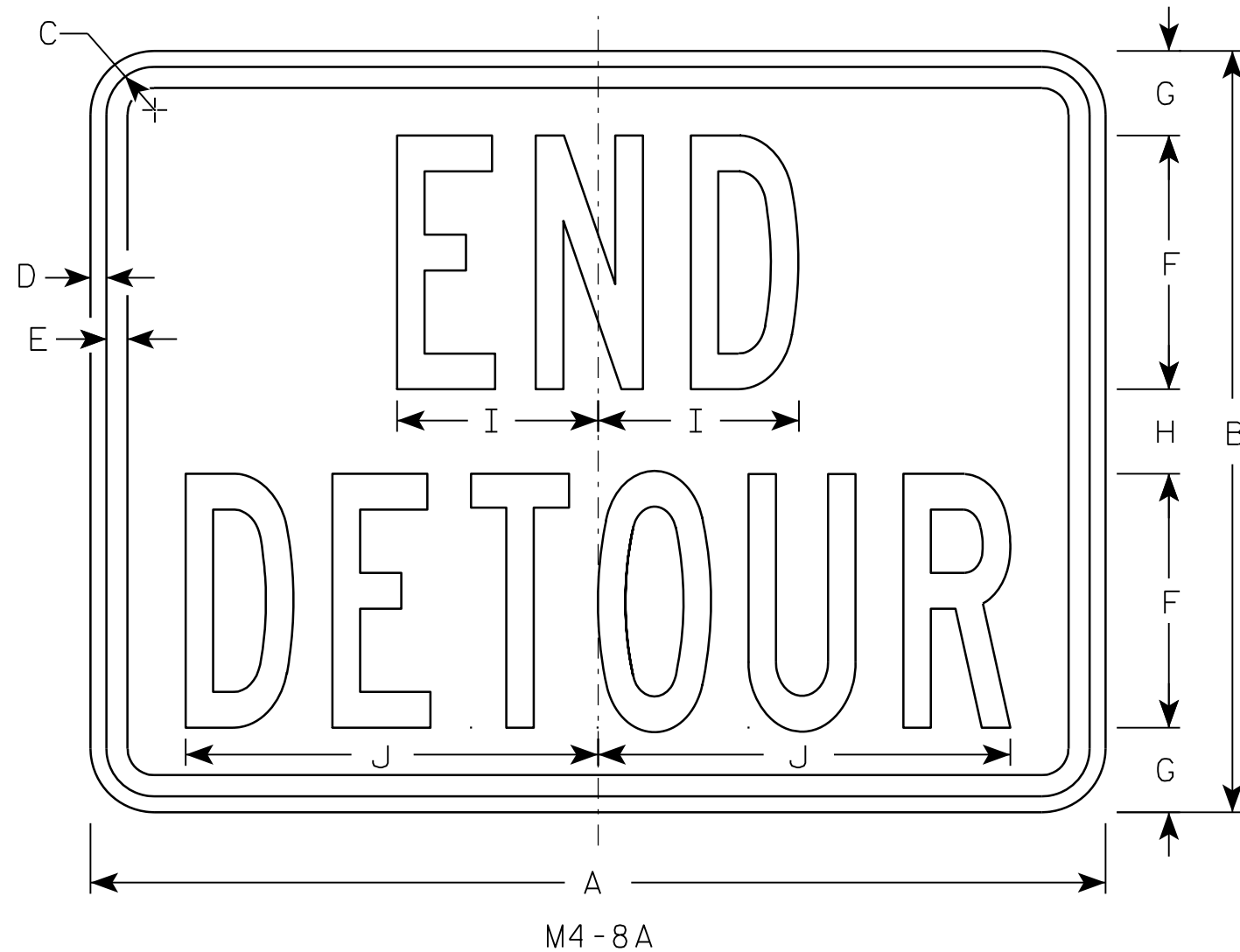

7

7

SIZE	A	B	C	D	E	F	G	H	I	J	K	L	M	N	O	P	Q	R	S	T	U	V	W	X	Y	Z	Area sq. ft.
1																											
2	24	18	1 1/8	3/8	1/2	6	2	2	4 3/4	9 3/4																	3.0
3	30	24	1 1/8	3/8	1/2	8	2 1/2	3	6 3/4	13																	5.0
4																											
5																											

STANDARD SIGN
M4-8A

WISCONSIN DEPT OF TRANSPORTATION

APPROVED *Matthew R. Rauch*
for State Traffic Engineer

DATE 3/9/11 PLATE NO. M4-8A.2

PROJECT NO: _____ HWY: _____ COUNTY: _____ SHEET NO: **E**

NOTES

1. Sign is Type II-Type F Reflective
2. Color:
Background - Orange
Message - Black
3. Message Series - D
4. Corners may be square or rounded when base material is plywood but borders shall be rounded as shown. When base material is metal, the corners and borders shall be rounded.
5. M4-9BL is the same as M4-9BR except the arrow is reversed.

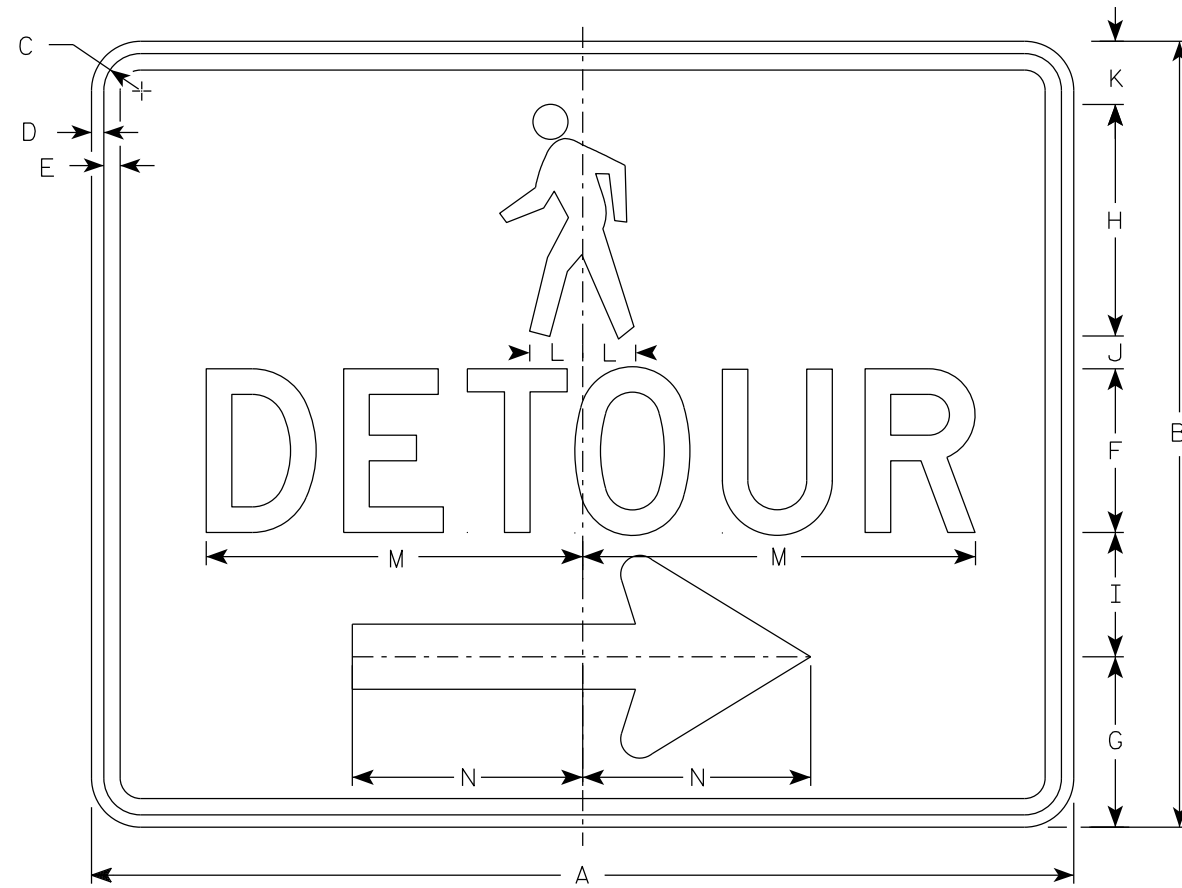

M4 - 9BR

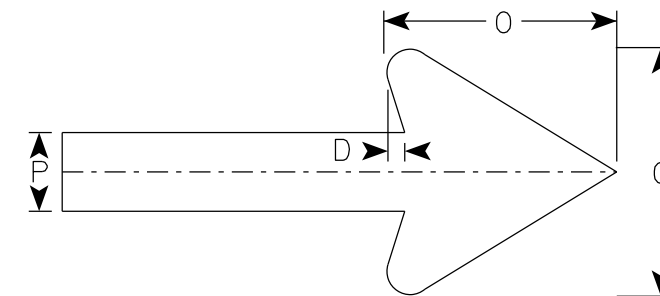

Arrow Detail

SIZE	A	B	C	D	E	F	G	H	I	J	K	L	M	N	O	P	Q	R	S	T	U	V	W	X	Y	Z	Area sq. ft.
1																											
2	30	24	1 1/8	3/8	1/2	5	5 1/4	7 1/8	3 3/4	1	1 1/8	1 5/8	11 3/4	7	6	2											5.00
3																											
4																											
5																											

STANDARD SIGN
M4-9B L&R

WISCONSIN DEPT OF TRANSPORTATION

APPROVED *Matthew R. Rauch*
For State Traffic Engineer

DATE 7/1/19 PLATE NO. M4-9B.2

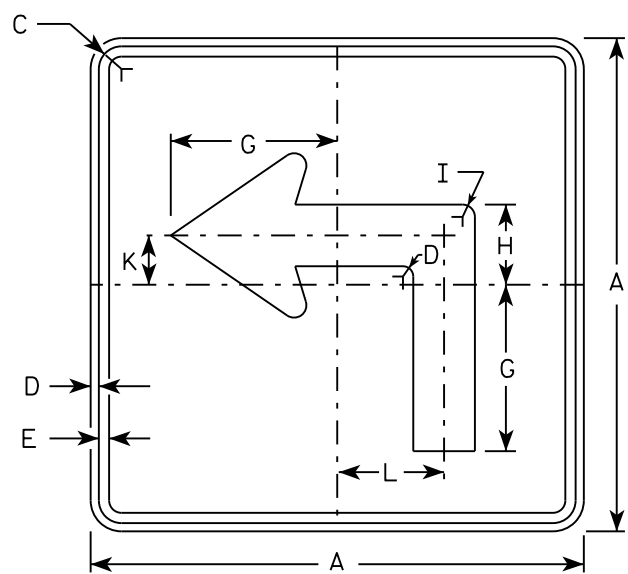

M5-1L
MM5-1L
M05-1L
MP5-1L

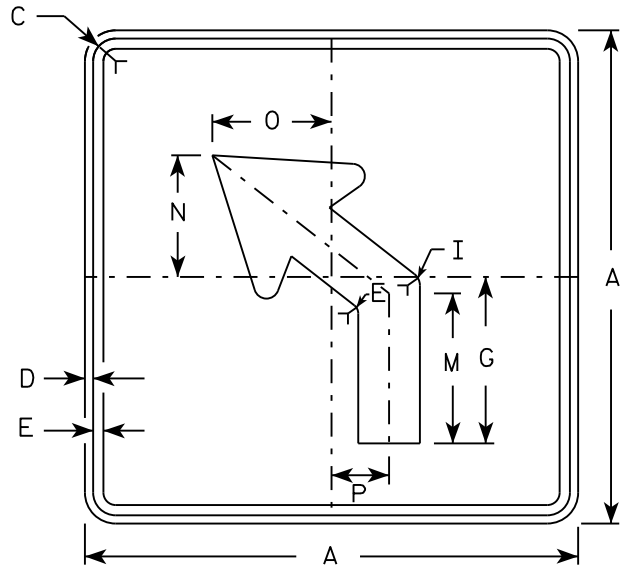

M5-2L
MM5-2L
M05-2L
MP5-2L

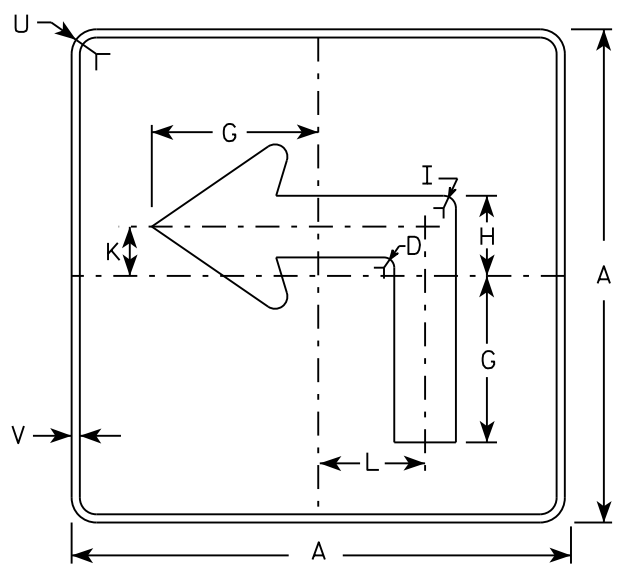

MB5-1L
MK5-1L
MN5-1L
MR5-1L

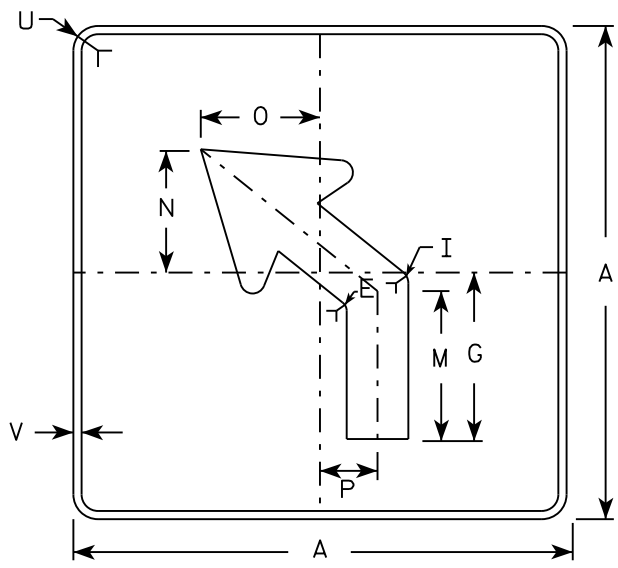

MB5-2L
MK5-2L
MN5-2L
MR5-2L

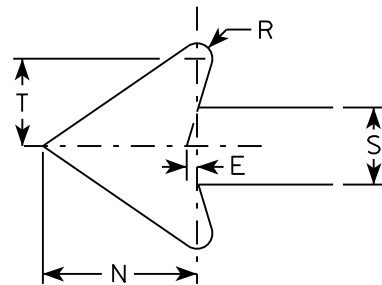

NOTES

- Signs are Type II - Type H reflective except as shown
- Color:
Background - See note 4
Message - See note 4
- Corners may be square or rounded when base material is plywood but borders shall be rounded as shown. When base material is metal, the corners and borders shall be rounded.
- | | |
|-----------------|---|
| M5-1 and M5-2 | Background - White |
| | Message - Black |
| MB5-1 and MB5-2 | Background - Blue |
| | Message - White |
| MK5-1 and MK5-2 | Background - Green |
| | Message - White |
| MM5-1 and MM5-2 | Background - White |
| | Message - Green |
| MN5-1 and MN5-2 | Background - Brown |
| | Message - White |
| M05-1 and M05-2 | Background - Orange - Type F Reflective |
| | Message - Black |
| MP5-1 and MP5-2 | Background - White - Type H Reflective |
| | Message - Blue |
| MR5-1 and MR5-2 | Background - Brown |
| | Message - Yellow |
- M5-1R same as M5-1L except arrow points right.
- M5-2R same as M5-2L except arrow tilts right.

SIZE	A	B	C	D	E	F	G	H	I	J	K	L	M	N	O	P	Q	R	S	T	U	V	W	X	Y	Z	Area sq. ft.
1																											
2	21		1 1/8	3/8	3/8		7	3 3/8	5/8		2 1/8	4 1/2	6 3/8	5 1/4	5	2 1/2		1/2	2 5/8	3	1 1/2	1/2					3.06
3	30		1 3/8	1/2	5/8		10 1/8	4 7/8	7/8		3	6 1/2	9 1/8	7 1/2	7 1/4	3 1/2		3/4	3 3/4	4 1/4	1 7/8	1/2					6.25
4	30		1 3/8	1/2	5/8		10 1/8	4 7/8	7/8		3	6 1/2	9 1/8	7 1/2	7 1/4	3 1/2		3/4	3 3/4	4 1/4	1 7/8	1/2					6.25
5	30		1 3/8	1/2	5/8		10 1/8	4 7/8	7/8		3	6 1/2	9 1/8	7 1/2	7 1/4	3 1/2		3/4	3 3/4	4 1/4	1 7/8	1/2					6.25

STANDARD SIGN
M5-1 & M5-2

WISCONSIN DEPT OF TRANSPORTATION

APPROVED *Matthew R. Rauch*
for State Traffic Engineer

DATE 10/15/15 PLATE NO. M5-1.13

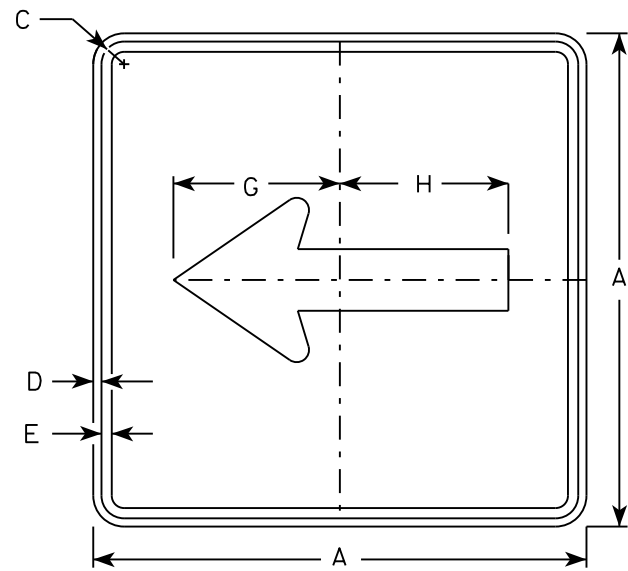

M6-1
MM6-1
M06-1
MP6-1

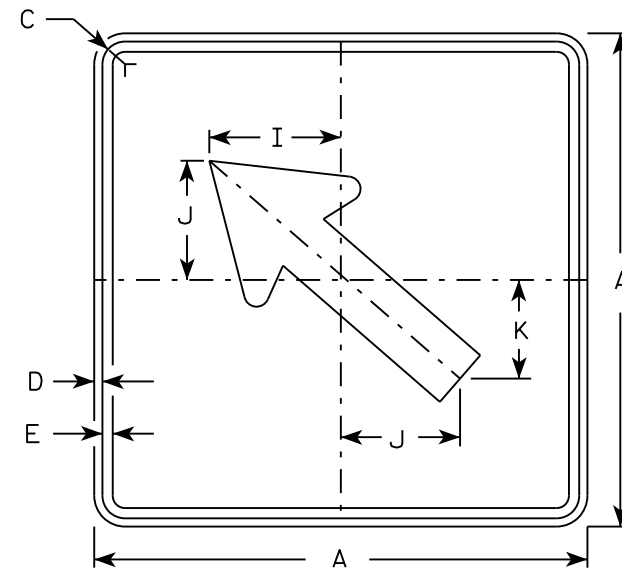

M6-2
MM6-2
M06-2
MP6-2

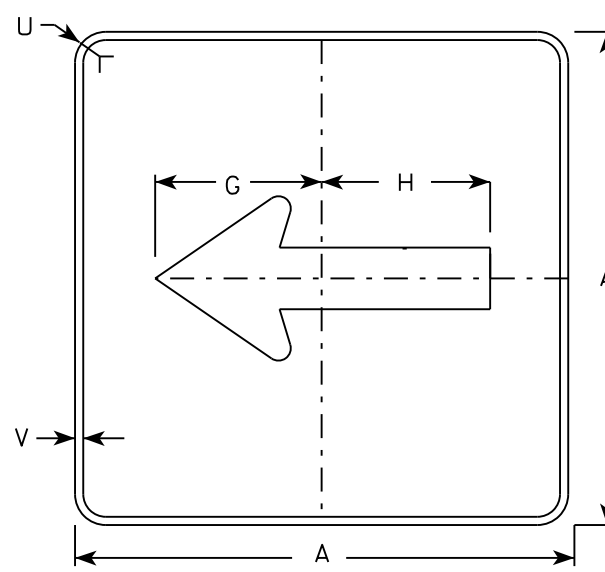

MB6-1
MK6-1
MN6-1
MR6-1

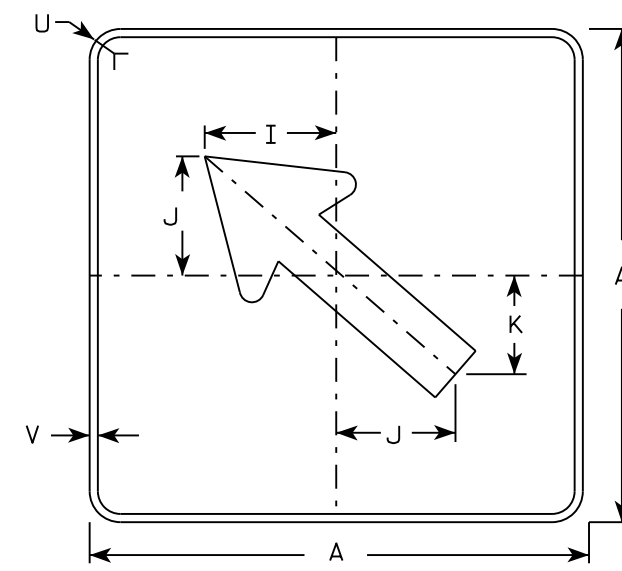

MB6-2
MK6-2
MN6-2
MR6-2

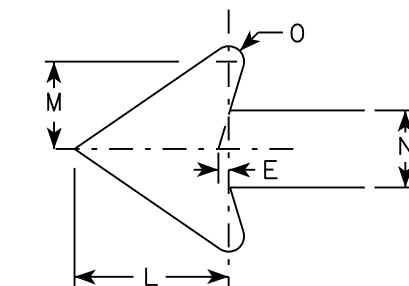

NOTES

- Signs are Type II - Type H except as Shown
- Color:
Background - See note 4
Message - See note 4
- Corners may be square or rounded when base material is plywood but borders shall be rounded as shown. When base material is metal, the corners and borders shall be rounded.
- M6-1 and M6-2 Background - White
Message - Black
MB6-1 and MB6-2 Background - Blue
Message - White
MK6-1 and MK6-2 Background - Green
Message - White
MM6-1 and MM6-2 Background - White
Message - Green
MN6-1 and MN6-2 Background - Brown
Message - White
M06-1 and M06-2 Background - Orange - Type F Reflective
Message - Black
MP6-1 and MP6-2 Background - White
Message - Blue
MR6-1 and MR6-2 Background - Brown
Message - Yellow

7

SIZE	A	B	C	D	E	F	G	H	I	J	K	L	M	N	O	P	Q	R	S	T	U	V	W	X	Y	Z	Area sq. ft.
1																											
2	21		1 1/8	3/8	3/8		7 1/2	7 1/8	5 5/8	5	4 1/4	5 1/4	3	2 5/8	1/2						1 1/2	1/2					3.06
3	30		1 3/8	1/2	5/8		10 3/4	10 1/4	8	7 1/4	6	7 1/2	4 1/4	3 3/4	3/4						1 7/8	1/2					6.25
4	30		1 3/8	1/2	5/8		10 3/4	10 1/4	8	7 1/4	6	7 1/2	4 1/4	3 3/4	3/4						1 7/8	1/2					6.25
5	30		1 3/8	1/2	5/8		10 3/4	10 1/4	8	7 1/4	6	7 1/2	4 1/4	3 3/4	3/4						1 7/8	1/2					6.25

STANDARD SIGN
M6-1 & M6-2
SERIES

WISCONSIN DEPT OF TRANSPORTATION

APPROVED *Matthew R. Rauch*
for State Traffic Engineer

DATE 10/15/15 PLATE NO. M6-1.15

NOTES

1. Sign is Type II - Type H Reflective - reference WIS DOT Standard Specification for HIGHWAY and STRUCTURE CONSTRUCTION latest edition.
2. Color:
Background - Red
Message - White
3. Message Series - C

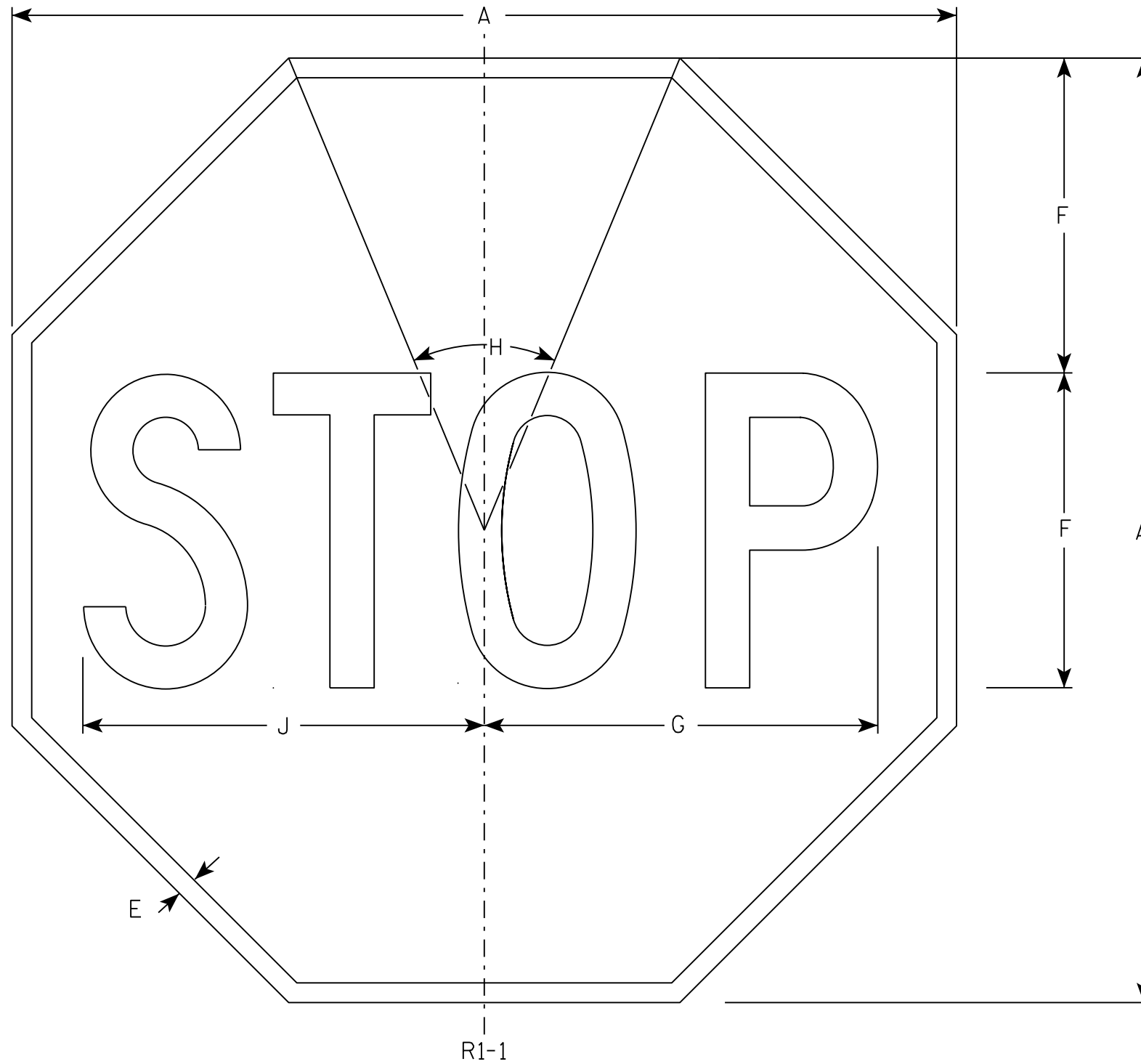

7

7

SIZE	A	B	C	D	E	F	G	H	I	J	K	L	M	N	O	P	Q	R	S	T	U	V	W	X	Y	Z	Area sq. ft.
1	30				5/8	10	12 1/2	45°		12 3/4																	5.18
2S	30				5/8	10	12 1/2	45°		12 3/4																	5.18
2M	36				3/4	12	15	45°		15 3/8																	7.46
3	36				3/4	12	15	45°		15 3/8																	7.46
4	48				1	16	20	45°		20 1/2																	13.25
5	48				1	16	20	45°		20 1/2																	13.25
6	18				3/8	6	7 3/4	45°		7 3/4																	1.86
7	12				1/4	4	5	45°		5 1/8																	0.78

PROJECT NO: _____ HWY: _____ COUNTY: _____ SHEET NO: **E**

STANDARD SIGN
R1-1

WISCONSIN DEPT OF TRANSPORTATION

APPROVED *Matthew R. Rauch*
for State Traffic Engineer

DATE 11/12/15 PLATE NO. R1-1.13

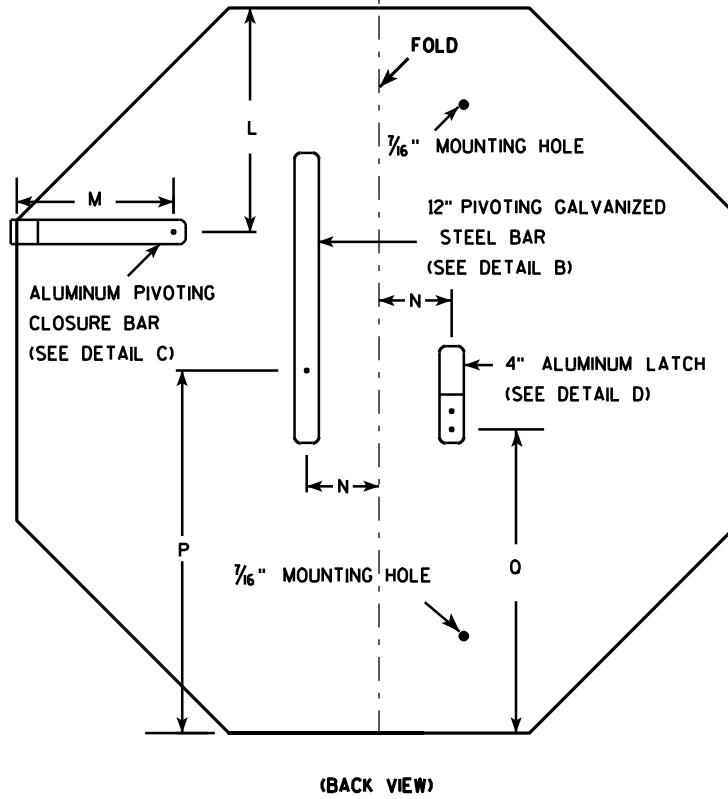
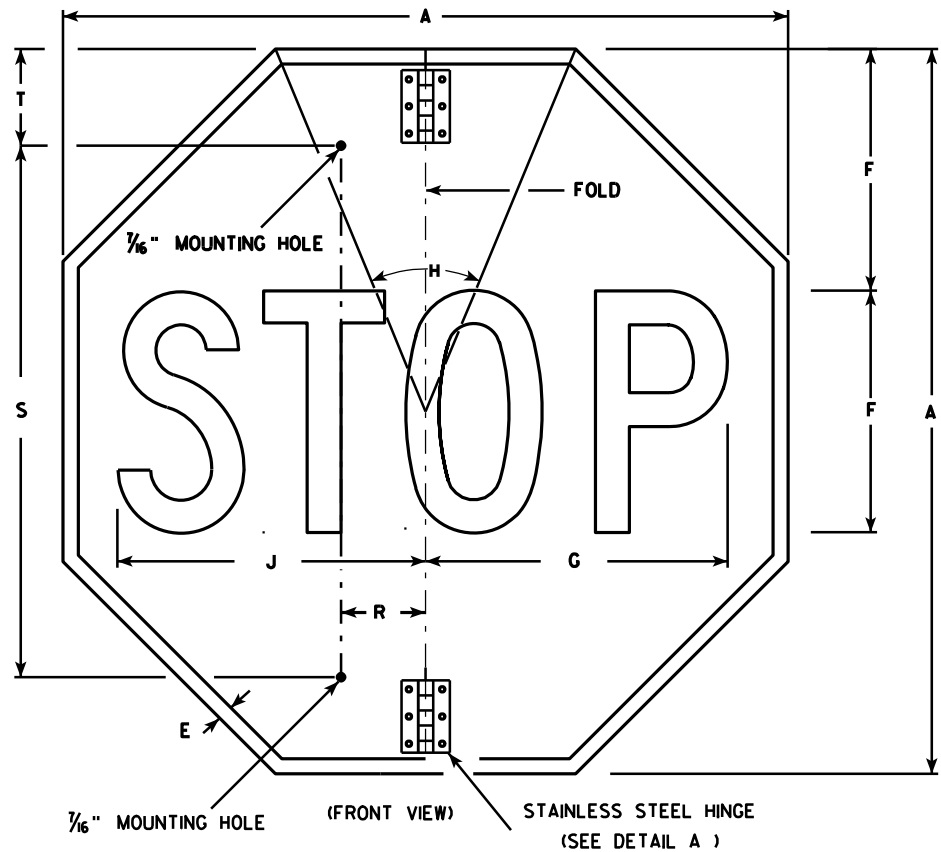

NOTES

1. Sign is Type II - Type H Reflective - reference WIS DOT Standard Specification for HIGHWAY and STRUCTURE CONSTRUCTION latest edition.
2. Color:
Background - Red
Message - White
3. Message Series - C
4. All hardware used on the folding STOP sign installation shall conform to 637.2.4 of the WIS DOT Standard Specification.

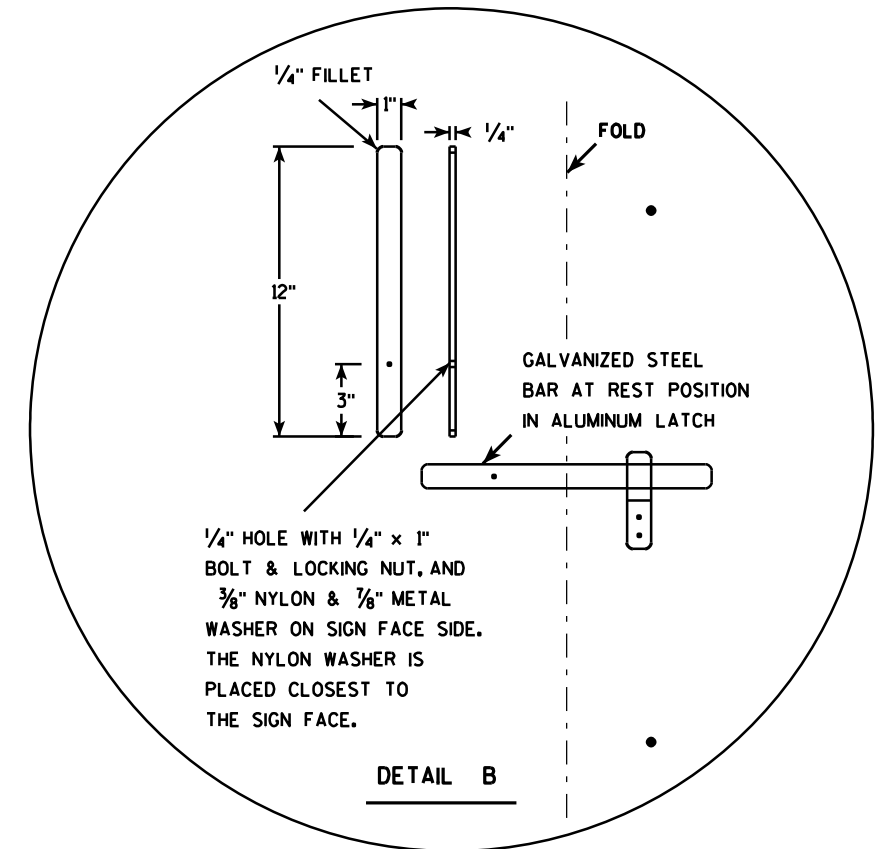
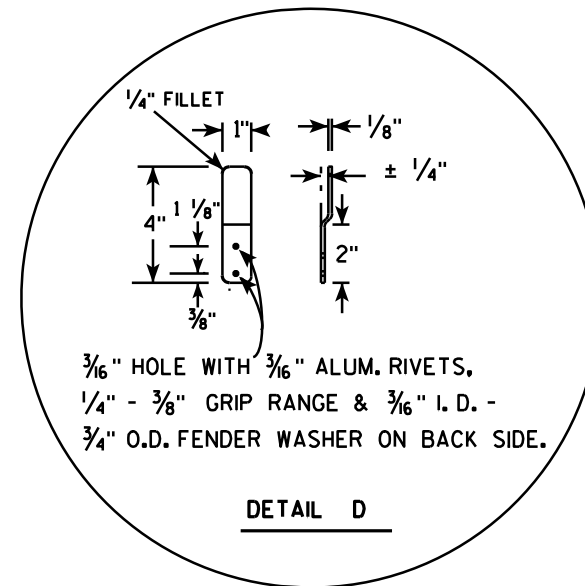
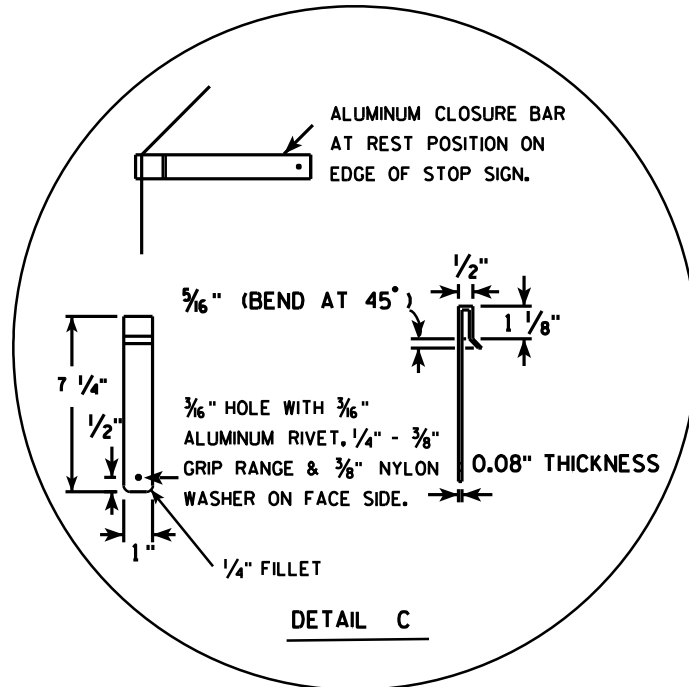
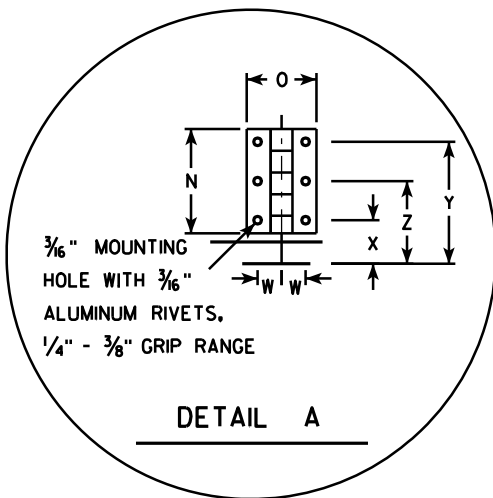

7

7

SIZE	A	B	C	D	E	F	G	H	I	J	K	L	M	N	O	P	Q	R	S	T	U	V	W	X	Y	Z	Area sq. ft.
1																											
2S	30				5/8	10	12 1/2	45		12 3/4		9 1/4	6 1/2	3	2	15	12 3/8	2 1/2	22	5			1 1/8	1 1/4	3 1/2	2 3/8	5.18
2M	36				3/4	12	15	45		15 3/8		11	6 1/2	3	2	18	15 3/8	2 1/2	26	5			1 1/8	1 1/4	3 1/2	2 3/8	7.46
3	36				3/4	12	15	45		15 3/8		11	6 1/2	3	2	18	15 3/8	2 1/2	26	5			1 1/8	1 1/4	3 1/2	2 3/8	7.46
4																											
5																											

STANDARD SIGN
R1-1F

WISCONSIN DEPT OF TRANSPORTATION

APPROVED *Matthew R. Rauch*
for State Traffic Engineer

DATE 12/03/10 PLATE NO. R1-1F.3

PROJECT NO: _____ HWY: _____ COUNTY: _____ SHEET NO: _____ E

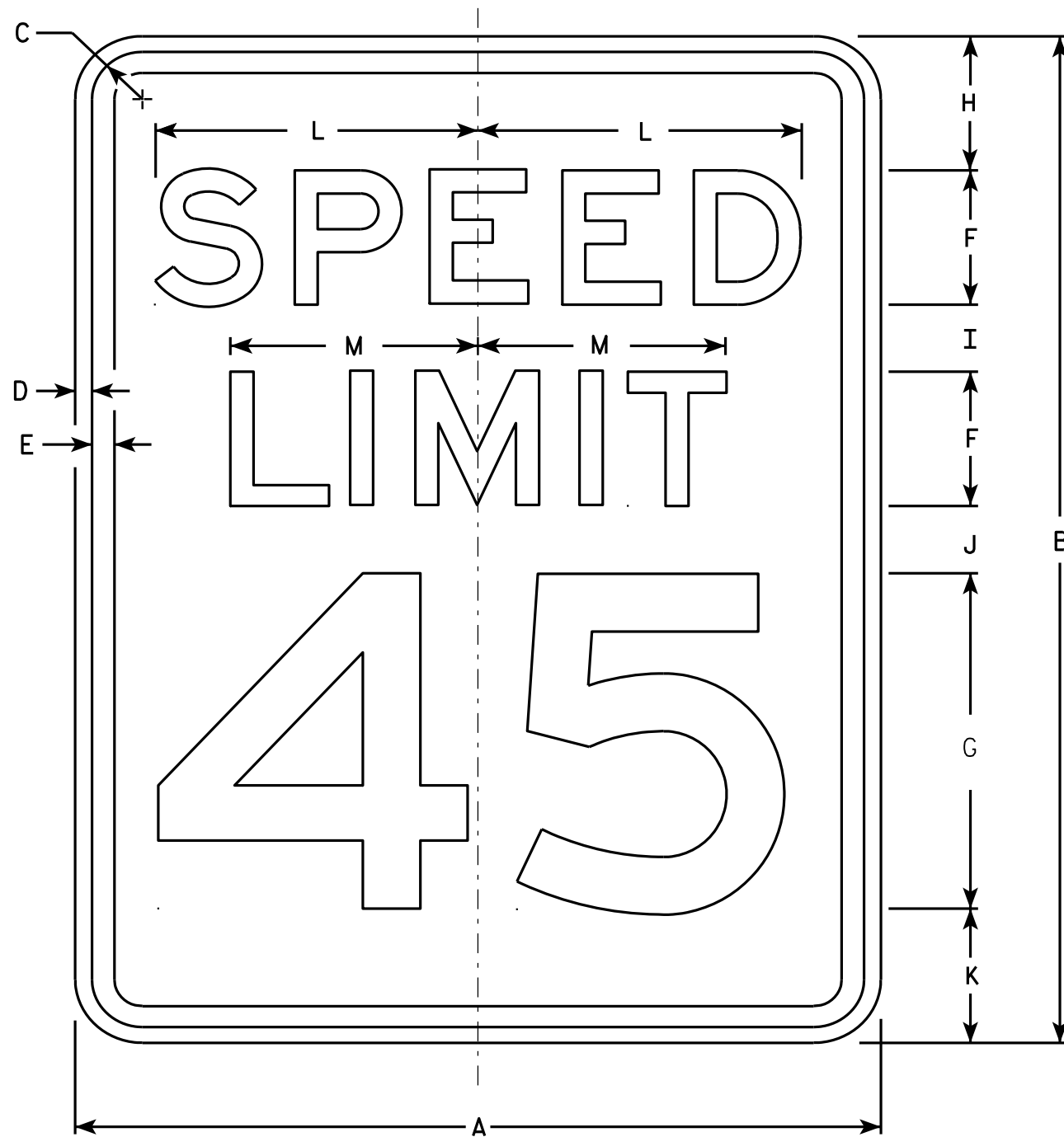

R2-1

NOTES

1. Sign is Type II - Type H Reflective - reference WIS DOT Standard Specification for HIGHWAY and STRUCTURE CONSTRUCTION latest edition.
2. Color:
Background - White
Message - Black
3. Message Series - E
4. Corners may be square or rounded when base material is plywood but borders shall be rounded as shown. When base material is metal, the corners and borders shall be rounded.
5. Substitute appropriate numerals and optically adjust spacing to achieve proper balance.

7

7

SIZE	A	B	C	D	E	F	G	H	I	J	K	L	M	N	O	P	Q	R	S	T	U	V	W	X	Y	Z	Area sq. ft.
1	18	24	1 1/8	3/8	1/2	3	8	3	2	2	3	7 1/4	5 1/2														3.0
2S	24	30	1 1/8	3/8	1/2	4	10	3	2 1/4	3 3/8	3 3/8	9 5/8	7 3/8														5.0
2M	30	36	1 3/8	1/2	5/8	5	12	5	2 1/2	2 1/2	4	12	9 1/4														7.5
3	36	48	1 3/8	1/2	5/8	6	14	6	5	5	6	14 3/8	11														12.0
4	36	48	1 3/8	1/2	5/8	6	14	6	5	5	6	14 3/8	11														12.0
5	48	60	2 1/4	3/4	1	8	20	6	4 1/2	6 3/4	6 3/4	19 1/4	14 5/8														20.0

STANDARD SIGN
R2-1

WISCONSIN DEPT OF TRANSPORTATION

APPROVED *Matthew R. Rauch*
For State Traffic Engineer

DATE 5/26/10 PLATE NO. R2-1.13

PROJECT NO: _____ HWY: _____ COUNTY: _____ SHEET NO: _____ E

NOTES

1. Sign is Type II - Type H Reflective - reference WIS DOT Standard Specification for HIGHWAY and STRUCTURE CONSTRUCTION latest edition.
2. Color:
Background - White
Message - Black
3. Message Series - D
4. Corners may be square or rounded when base material is plywood but borders shall be rounded as shown. When base material is metal, the corners and borders shall be rounded.

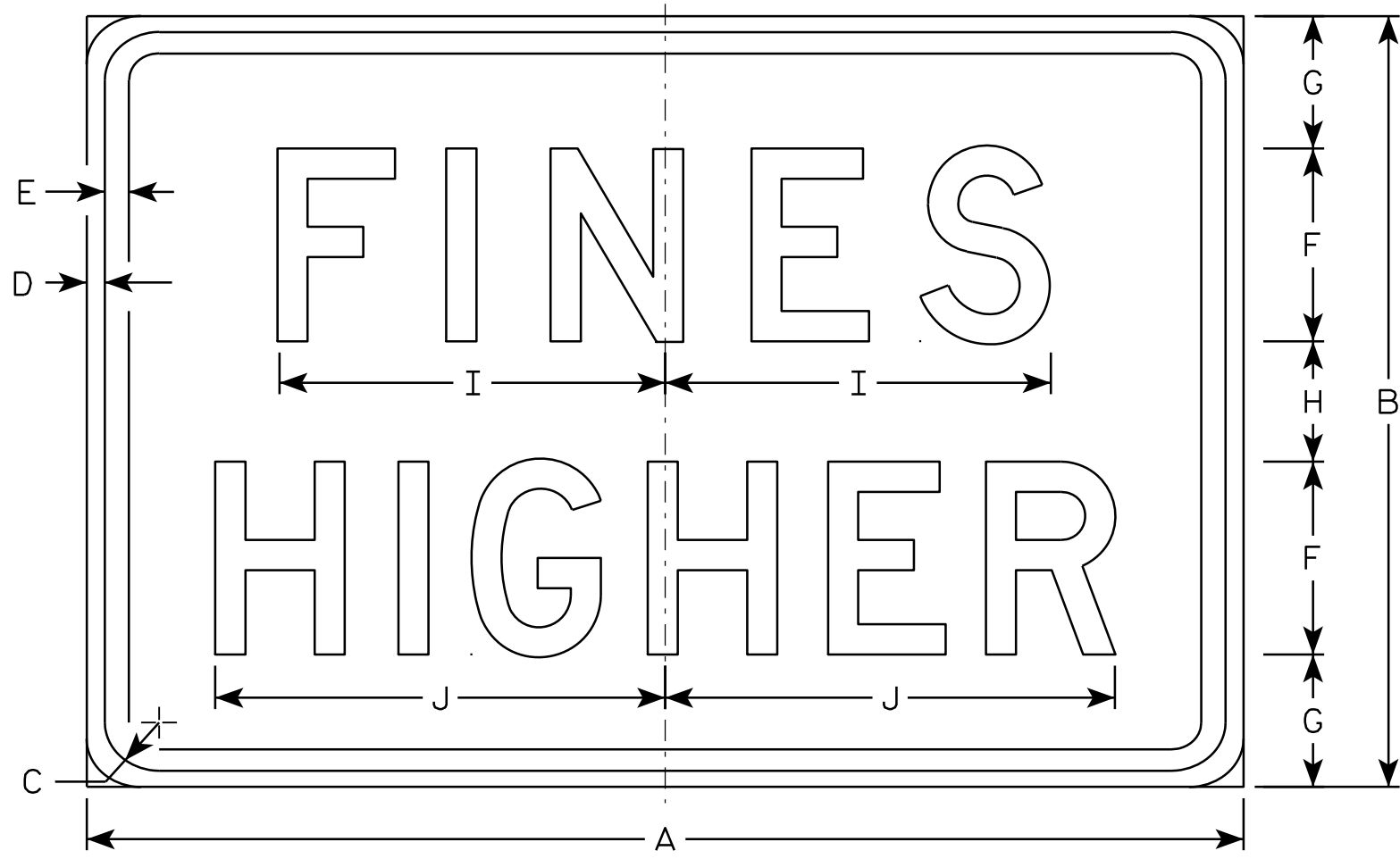

R2-6P

7

7

SIZE	A	B	C	D	E	F	G	H	I	J	K	L	M	N	O	P	Q	R	S	T	U	V	W	X	Y	Z	Area sq. ft.
1																											
2S	24	18	1 1/8	3/8	3/8	4	3 1/2	3	7 5/8	9 1/4																	3.0
2M	24	18	1 1/8	3/8	3/8	4	3 1/2	3	7 5/8	9 1/4																	3.0
3	36	24	1 1/8	3/8	1/2	6	4 1/8	3 3/4	12	14																	6.0
4	36	24	1 1/8	3/8	1/2	6	4 1/8	3 3/4	12	14																	6.0
5	48	36	1 3/8	1/2	5/8	8	7	6	15 1/8	19																	12.0

STANDARD SIGN
R2-6P

WISCONSIN DEPT OF TRANSPORTATION

APPROVED *Matthew R. Rauch*
For State Traffic Engineer

DATE 12/20/10 PLATE NO. R2-6P.2

PROJECT NO: _____ HWY: _____ COUNTY: _____ SHEET NO: _____ E

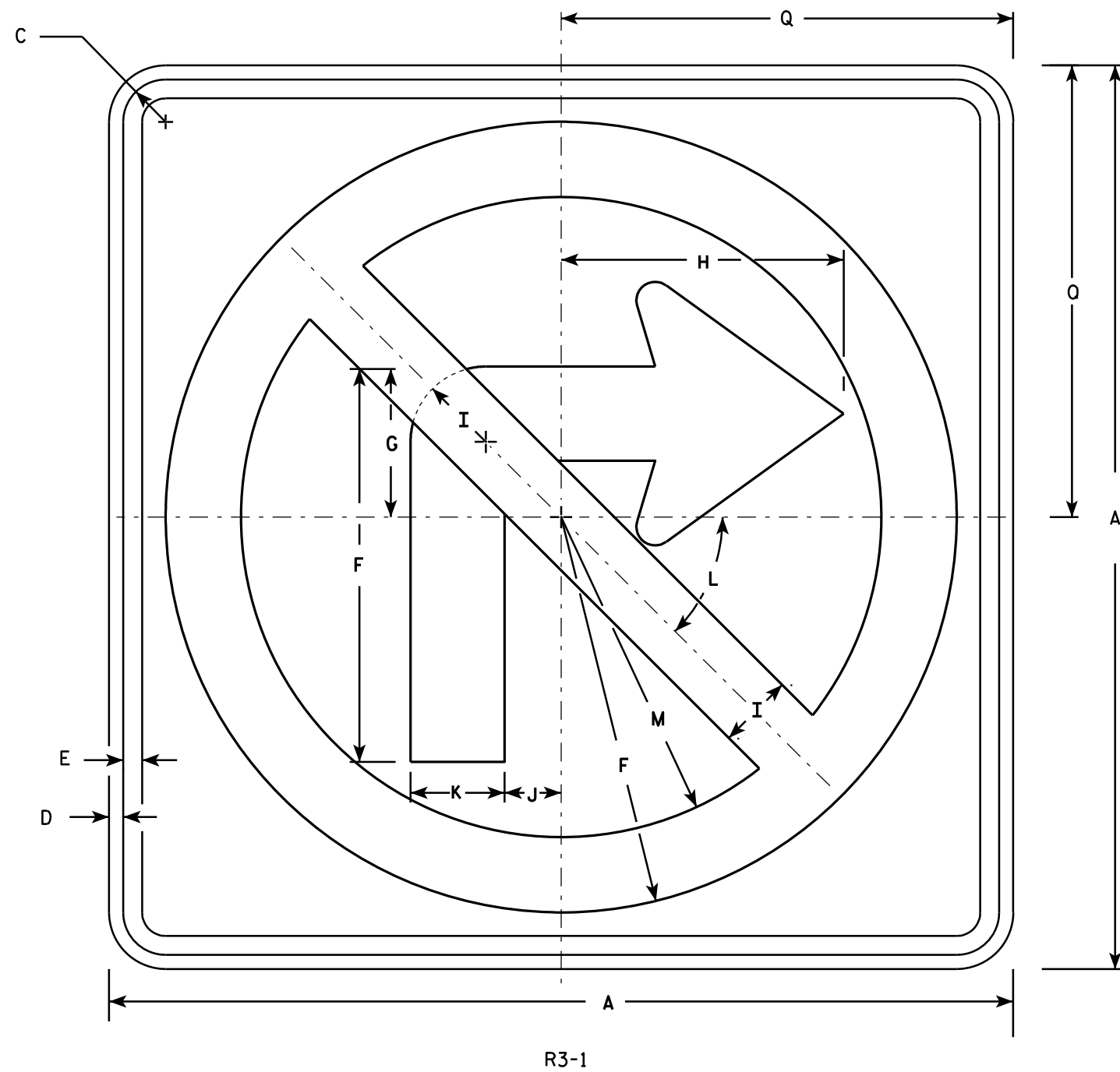

NOTES

1. Sign is Type II - Type H Reflective - reference WIS DOT Standard Specification for HIGHWAY and STRUCTURE CONSTRUCTION latest edition.
2. Color:
Background - White
Message - See note 4
3. Corners may be square or rounded when base material is plywood but borders shall be rounded as shown. When base material is metal, the corners and borders shall be rounded.
4. Border & Arrow are non reflective black, the circle with diagonal bar is reflective red.

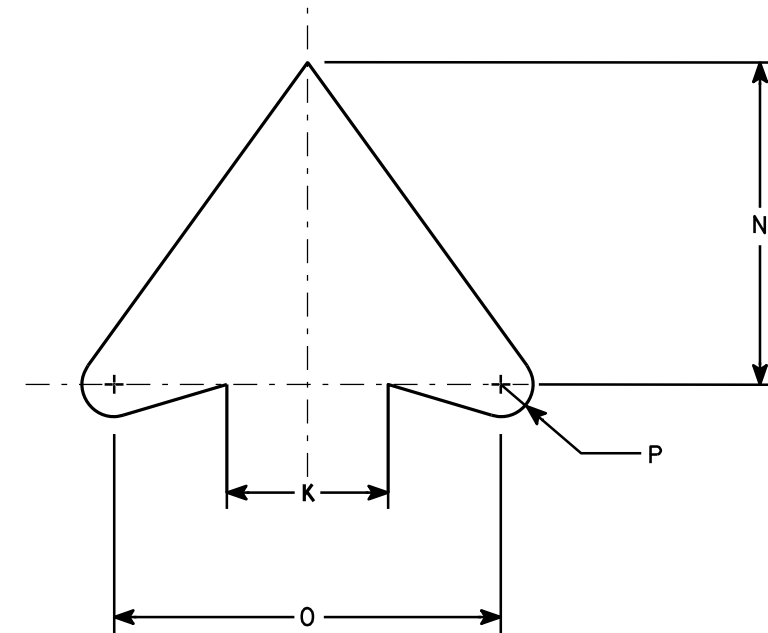

ARROW DETAIL

R3-1

7

7

SIZE	A	B	C	D	E	F	G	H	I	J	K	L	M	N	O	P	Q	R	S	T	U	V	W	X	Y	Z	Area sq. ft.
1	24		1 1/8	3/8	1/2	10 1/2	4	7 1/2	2	1 1/2	2 1/2	45	8 1/2	5	6	1/2	12										4.0
2S	24		1 1/8	3/8	1/2	10 1/2	4	7 1/2	2	1 1/2	2 1/2	45°	8 1/2	5	6	1/2	12										4.0
2M	36		1 5/8	5/8	3/4	15 3/4	6	11 1/4	3	2 1/4	3 3/4	45	12 3/4	7 1/2	9	3/4	18										9.0
3	36		1 5/8	5/8	3/4	15 3/4	6	11 1/4	3	2 1/4	3 3/4	45	12 3/4	7 1/2	9	3/4	18										9.0
4	36		1 5/8	5/8	3/4	15 3/4	6	11 1/4	3	2 1/4	3 3/4	45°	12 3/4	7 1/2	9	3/4	18										9.0
5	48		2 1/4	3/4	1	21	8	15	4	3	5	45°	17	10	12	1	24										16.0

STANDARD SIGN

R3-1

WISCONSIN DEPT OF TRANSPORTATION

APPROVED *Matthew R. Rauch*
for State Traffic Engineer

DATE 12/08/10 PLATE NO. R3-1.5

PROJECT NO:

HWY:

COUNTY:

SHEET NO:

E

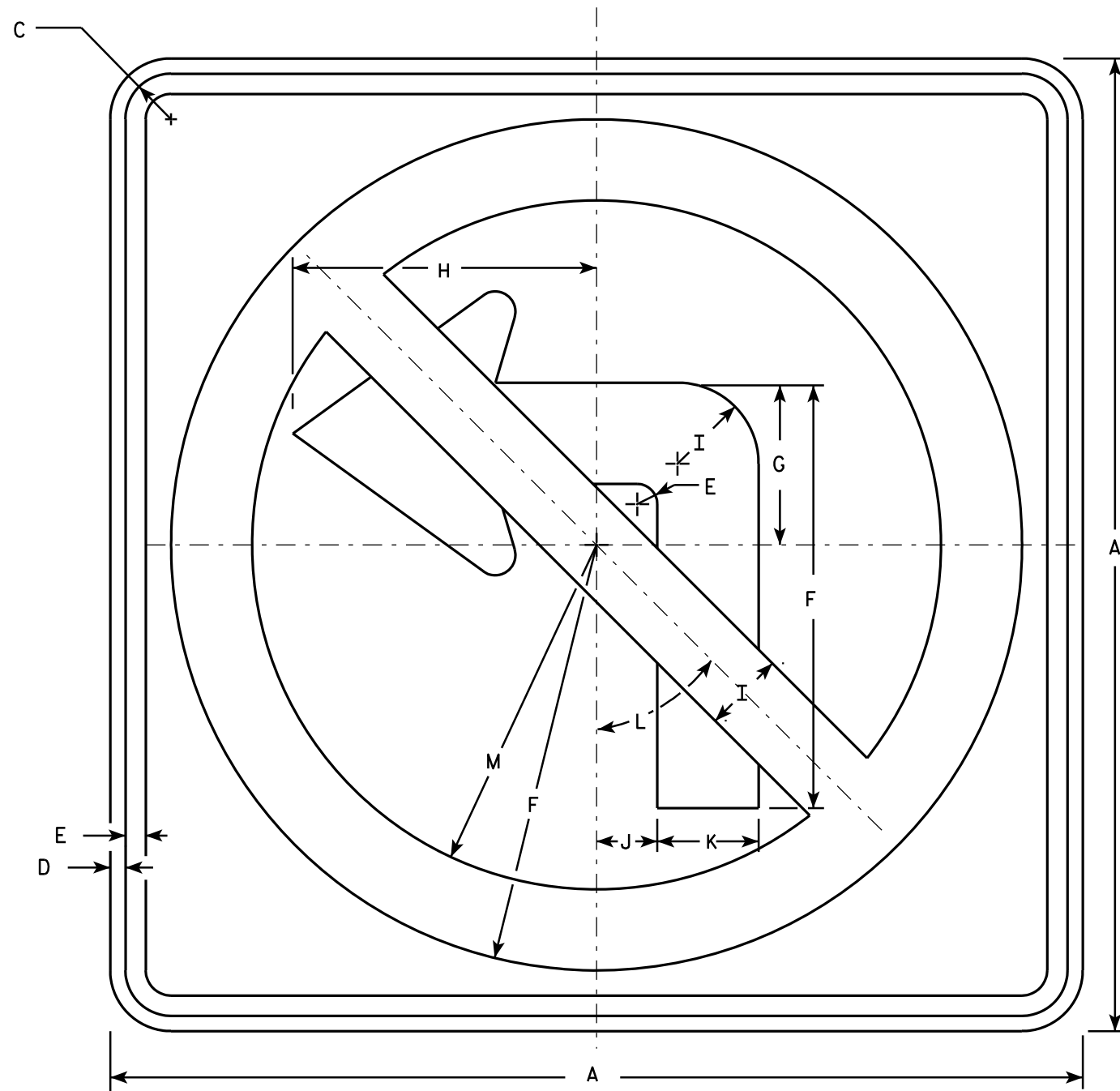

R3-2

NOTES

1. Sign is Type II - Type H Reflective - reference WIS DOT Standard Specification for HIGHWAY and STRUCTURE CONSTRUCTION latest edition.
2. Color:
Background - White
Message - See note 4
3. Corners may be square or rounded when base material is plywood but borders shall be rounded as shown. When base material is metal, the corners and borders shall be rounded.
4. Border & Arrow are non reflective black, the circle with diagonal bar is reflective red.

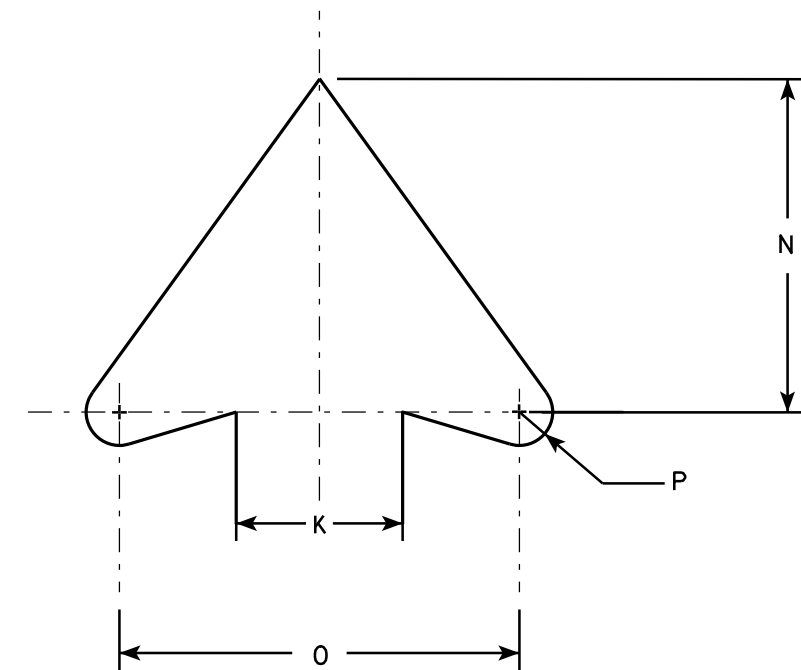

ARROW DETAIL

SIZE	A	B	C	D	E	F	G	H	I	J	K	L	M	N	O	P	Q	R	S	T	U	V	W	X	Y	Z	Area sq. Ft.
1	24		1 1/8	3/8	1/2	10 1/2	4	7 1/2	2	1 1/2	2 1/2	45°	8 1/2	5	6	1/2											4.0
2S	24		1 1/8	3/8	1/2	10 1/2	4	7 1/2	2	1 1/2	2 1/2	45°	8 1/2	5	6	1/2											4.0
2M	36		1 5/8	5/8	3/4	15 3/4	6	11 1/4	3	2 1/4	3 3/4	45°	12 3/4	7 1/2	9	3/4											9.0
3	36		1 5/8	5/8	3/4	15 3/4	6	11 1/4	3	2 1/4	3 3/4	45°	12 3/4	7 1/2	9	3/4											9.0
4	36		1 5/8	5/8	3/4	15 3/4	6	11 1/4	3	2 1/4	3 3/4	45°	12 3/4	7 1/2	9	3/4											9.0
5	48		2 1/4	3/4	1	21	8	15	4	3	5	45°	17	10	12	1											16.0

STANDARD SIGN
R3-2

WISCONSIN DEPT OF TRANSPORTATION

APPROVED *Matthew R. Rauch*
For State Traffic Engineer

DATE 12/08/10 PLATE NO. R3-2.10

PROJECT NO: _____ HWY: _____ COUNTY: _____ SHEET NO: _____ E



R3-17

NOTES

1. Sign is Type II - Type H Reflective - reference WIS DOT Standard Specification for HIGHWAY and STRUCTURE CONSTRUCTION latest edition.
2. Color:
Background - AS SHOWN
Message - BLACK
3. Message Series - C or as noted on the Signs.
4. Corners may be square or rounded when base material is plywood but borders shall be rounded as shown. When base material is metal, the corners and borders shall be rounded.

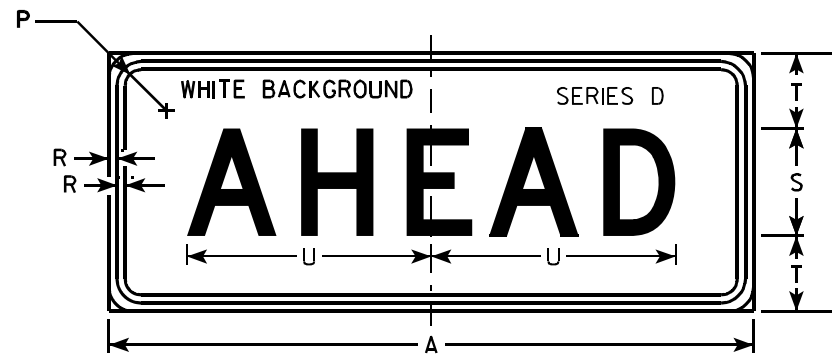

R3-17ap

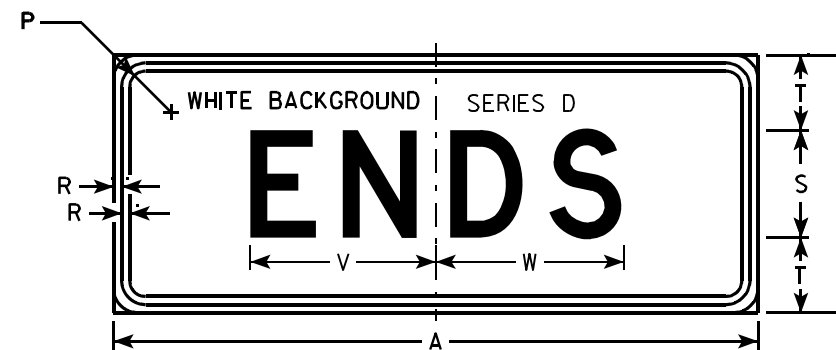

R3-17bp

SIZE	A	B	C	D	E	F	G	H	I	J	K	L	M	N	O	P	Q	R	S	T	U	V	W	X	Y	Z	R3-17 Area sq. ft.	R3-17ap Area sq. ft.	R3-17bp Area sq. ft.
1																													
2S	30	24	1 1/8	3/8	1/2	2	4	4 1/8	7 7/8	6 3/8	9 1/2	2 5/8	7/8	13	12	1 1/8	3 3/8	3/8	5	3 1/2	11 3/8	8 5/8	8 3/4	2 3/8	15 5/8	8	5.0	2.5	2.5
2M	30	24	1 1/8	3/8	1/2	2	4	4 1/8	7 7/8	6 3/8	9 1/2	2 5/8	7/8	13	12	1 1/8	3 3/8	3/8	5	3 1/2	11 3/8	8 5/8	8 3/4	2 3/8	15 5/8	8	5.0	2.5	2.5
3																													
4																													
5																													

STANDARD SIGN
R3-17 & R3-17a&bp

WISCONSIN DEPT OF TRANSPORTATION

APPROVED *Matthew R. Rauch*
For State Traffic Engineer

DATE 4/12/2011 PLATE NO. R3-17.2

NOTES

1. Sign is Type II - Type H Reflective - reference WIS DOT Standard Specification for HIGHWAY and STRUCTURE CONSTRUCTION latest edition.
2. Color:
Background - White
Message - Black
3. Message Series - D
4. Corners may be square or rounded when base material is plywood but borders shall be rounded as shown. When base material is metal, the corners and borders shall be rounded.
5. R3-53L same as R3-53R except LEFT is substituted for RIGHT.

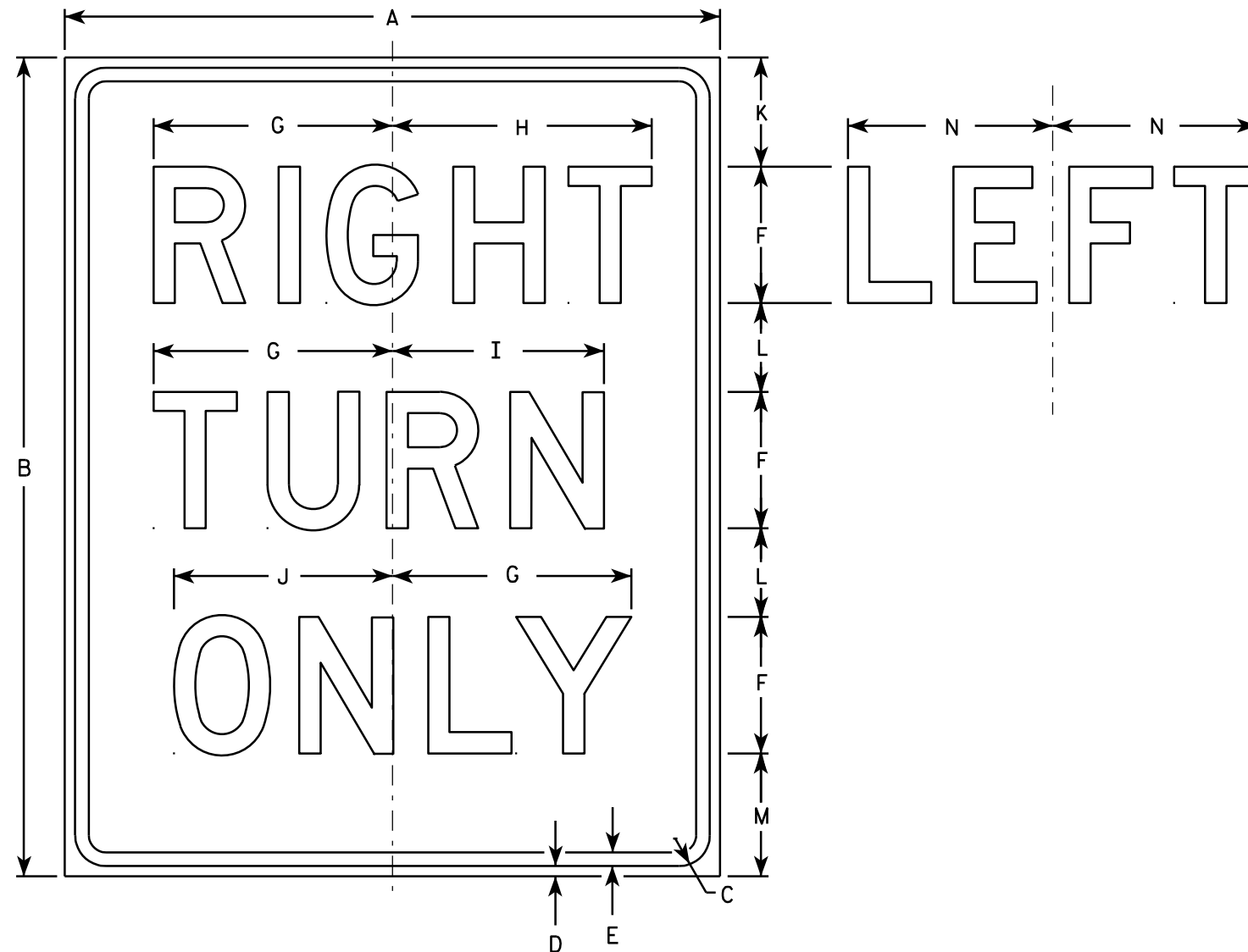

R3-53R

7

7

SIZE	A	B	C	D	E	F	G	H	I	J	K	L	M	N	O	P	Q	R	S	T	U	V	W	X	Y	Z	Area sq. ft.
1																											
2S	24	30	1 1/8	3/8	1/2	5	8 3/4	9 1/2	7 3/4	8	4	3 1/4	4 1/2	7 1/2													5.0
2M	24	30	1 1/8	3/8	1/2	5	8 3/4	9 1/2	7 3/4	8	4	3 1/4	4 1/2	7 1/2													5.0
3	24	30	1 1/8	3/8	1/2	5	8 3/4	9 1/2	7 3/4	8	4	3 1/4	4 1/2	7 1/2													5.0
4																											
5																											

STANDARD SIGN
R3-53

WISCONSIN DEPT OF TRANSPORTATION

APPROVED *Matthew R. Rauch*
For State Traffic Engineer

DATE 3/24/2011 PLATE NO. R3-53.8

PROJECT NO: _____ HWY: _____ COUNTY: _____ SHEET NO: _____ E

NOTES

1. Sign is Type II - Type H Reflective - reference WIS DOT Standard Specification for HIGHWAY and STRUCTURE CONSTRUCTION latest edition. material is plywood but borders shall be rounded
2. Color:
Background - White
Message - Black
3. Corners may be square or rounded when base as shown. When base material is metal, the corners and borders shall be rounded.
4. R4-8 is the same as R4-7 except Legend is reversed.

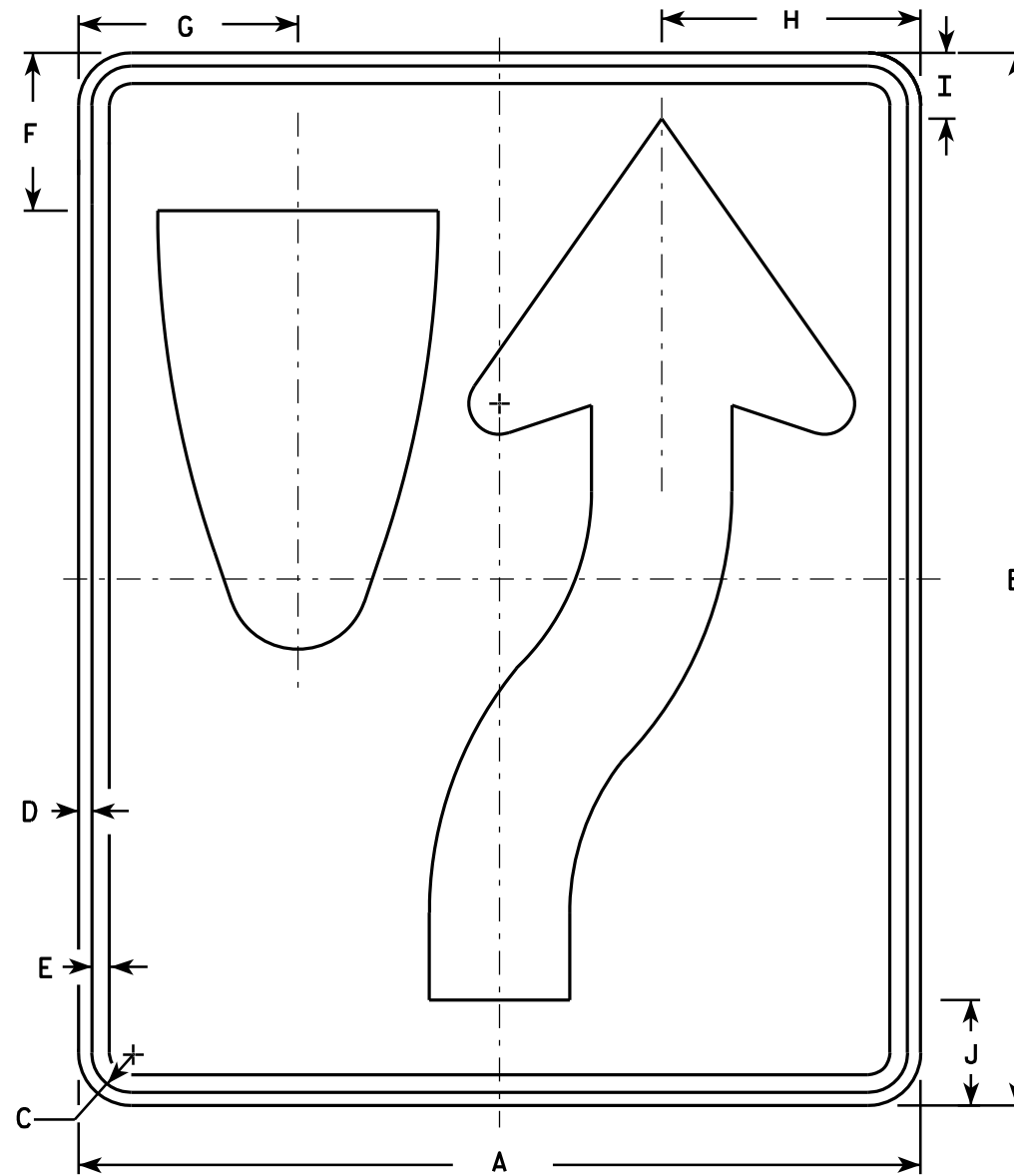
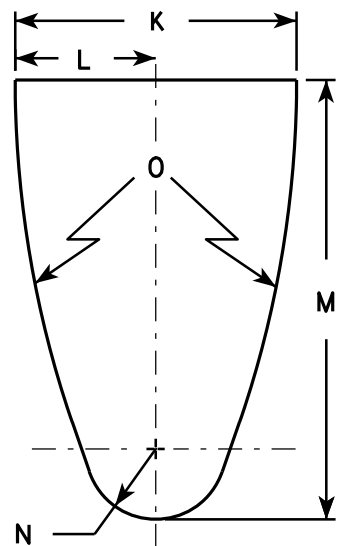

R4-7

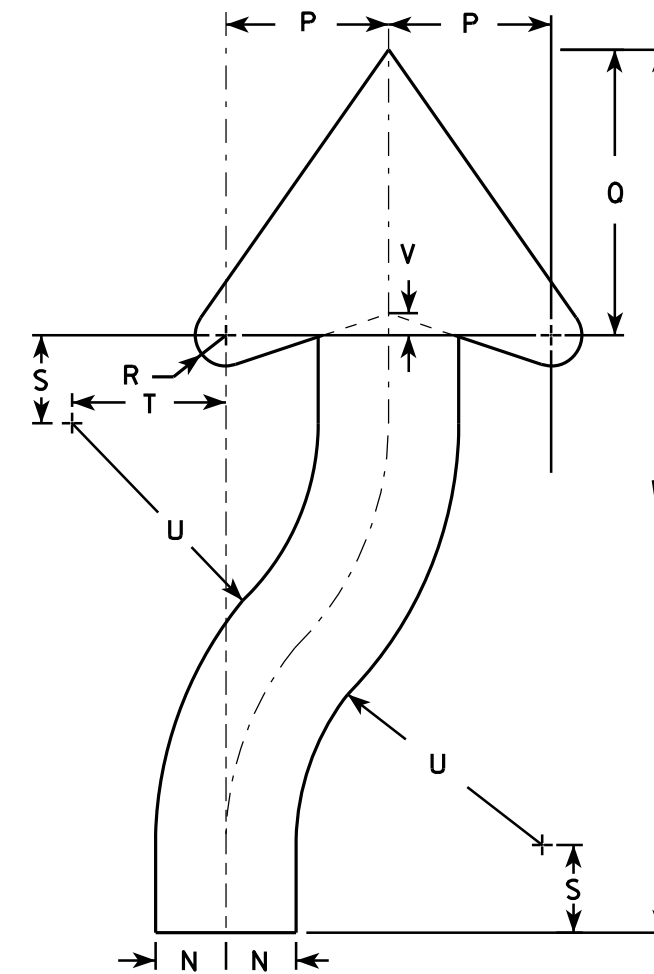

ARROW DETAIL

SIZE	A	B	C	D	E	F	G	H	I	J	K	L	M	N	O	P	Q	R	S	T	U	V	W	X	Y	Z	Area sq. ft.
1	18	24	1 1/8	3/8	1/2	3 3/8	4 3/4	5 1/2	1 3/8	2 1/4	6	3	9 3/8	1 1/2	22 1/2	3 1/2	6 1/8	5/8	1 7/8	3 1/4	6 3/4	1/2	20 3/8				3.0
2S	24	30	1 1/8	3/8	1/2	4 1/2	6 1/4	7 3/8	1 7/8	3	8	4	12 1/2	2	30	4 5/8	8 1/8	7/8	2 1/2	4 3/8	9	5/8	25 1/8				5.0
2M	24	30	1 1/8	3/8	1/2	4 1/2	6 1/4	7 3/8	1 7/8	3	8	4	12 1/2	2	30	4 5/8	8 1/8	7/8	2 1/2	4 3/8	9	5/8	25 1/8				5.0
3	36	48	1 3/4	1/2	5/8	6 3/4	9 3/8	11 1/8	2 7/8	4 1/2	12	6	18 3/4	3	45	6 7/8	12 1/4	1 1/4	3 3/4	6 5/8	13 1/2	1	40 3/4				12.0
4	36	48	1 3/4	1/2	5/8	6 3/4	9 3/8	11 1/8	2 7/8	4 1/2	12	6	18 3/4	3	45	6 7/8	12 1/4	1 1/4	3 3/4	6 5/8	13 1/2	1	40 3/4				12.0
5	48	60	2 1/4	3/4	1	9	12 1/2	14 3/4	3 3/4	6	16	8	25	4	60	9 1/4	16 1/4	1 5/8	5	8 3/4	18	1 1/4	50 1/4				20.0

STANDARD SIGN
R4-7 & R4-8

WISCONSIN DEPT OF TRANSPORTATION

APPROVED *Matthew R. Rauch*
for State Traffic Engineer

DATE 3/25/2011 PLATE NO. R4-7.8

PROJECT NO: _____ HWY: _____ COUNTY: _____ SHEET NO: _____ E

NOTES

1. Sign is Type II - Type H Reflective
2. Color:
Background - See detail
Message - White
3. Message Series - D

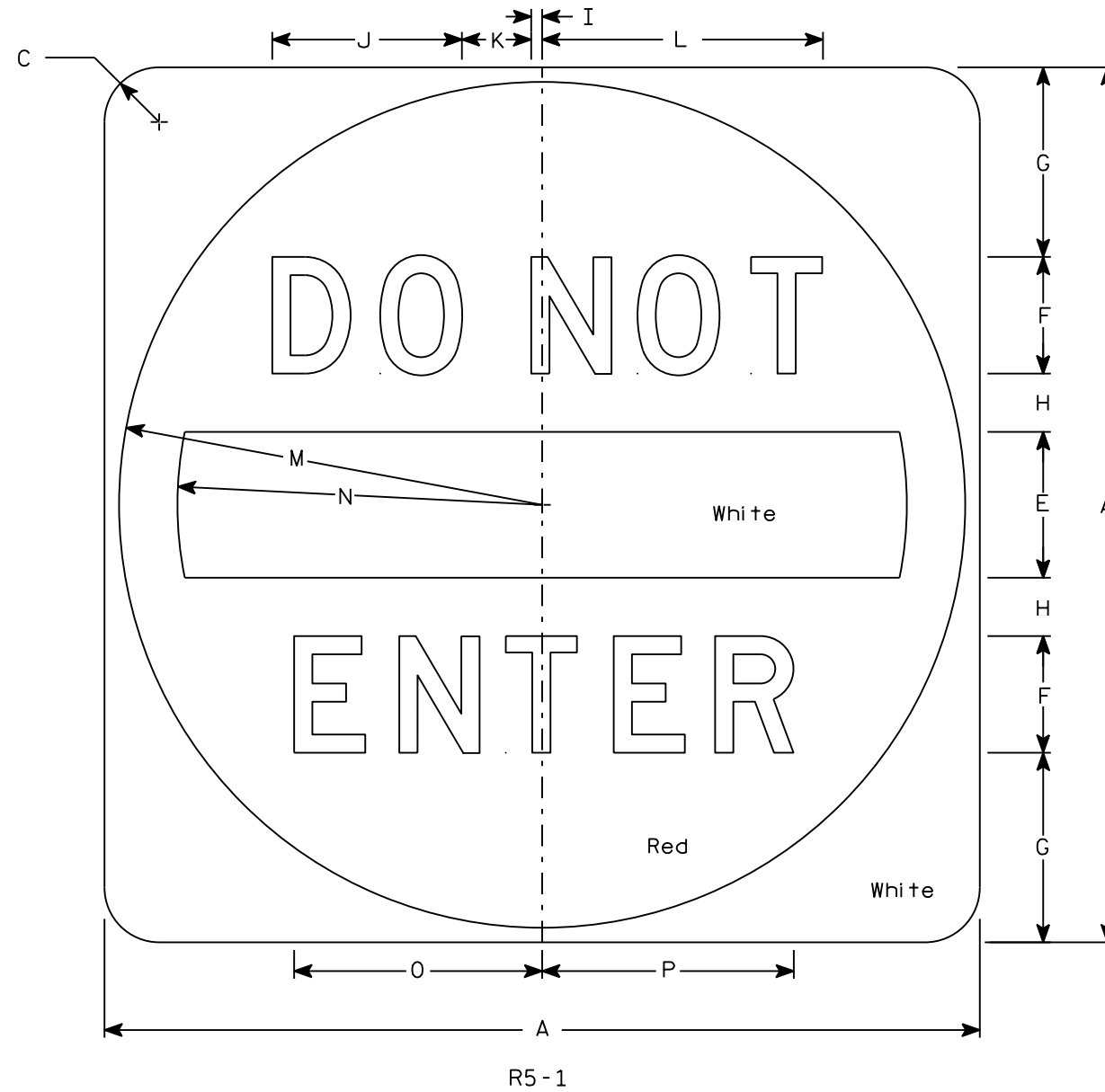

7

7

SIZE	A	B	C	D	E	F	G	H	I	J	K	L	M	N	O	P	Q	R	S	T	U	V	W	X	Y	Z	Area sq. ft.
1																											
2S	30		1 7/8		5	4	6 1/2	2	3/8	6 1/2	2 3/8	9 5/8	14 1/2	12 1/2	8 1/2	8 5/8											6.25
2M	36		2 1/4		6	5	7 1/2	2 1/2	1/2	8 1/8	3	12 1/8	17 1/2	15	10 5/8	10 3/4											9.0
3	36		2 1/4		6	5	7 1/2	2 1/2	1/2	8 1/8	3	12 1/8	17 1/2	15	10 5/8	10 3/4											9.0
4	36		2 1/4		6	5	7 1/2	2 1/2	1/2	8 1/8	3	12 1/8	17 1/2	15	10 5/8	10 3/4											9.0
5	48		3		8	6	11	3	5/8	9 3/4	3 5/8	14 1/2	23 1/2	20	12 3/4	12 7/8											16.0

STANDARD SIGN
R5-1

WISCONSIN DEPT OF TRANSPORTATION

APPROVED *Matthew R. Rauch*
for State Traffic Engineer

DATE 3/15/18 PLATE NO. R5-1.16

PROJECT NO: _____ HWY: _____ COUNTY: _____ SHEET NO: _____ **E**

NOTES

1. Sign is Type II - Type H Reflective - reference WIS DOT Standard Specification for HIGHWAY and STRUCTURE CONSTRUCTION latest edition.
2. Color:
Background - White
Message - See Note 4
3. Corners may be square or rounded when base material is plywood but borders shall be rounded as shown. When base material is metal, the corners and borders shall be rounded.
4. Circle & Diagonal - Reflective red.
Truck Symbol & Border - Non-reflective black.

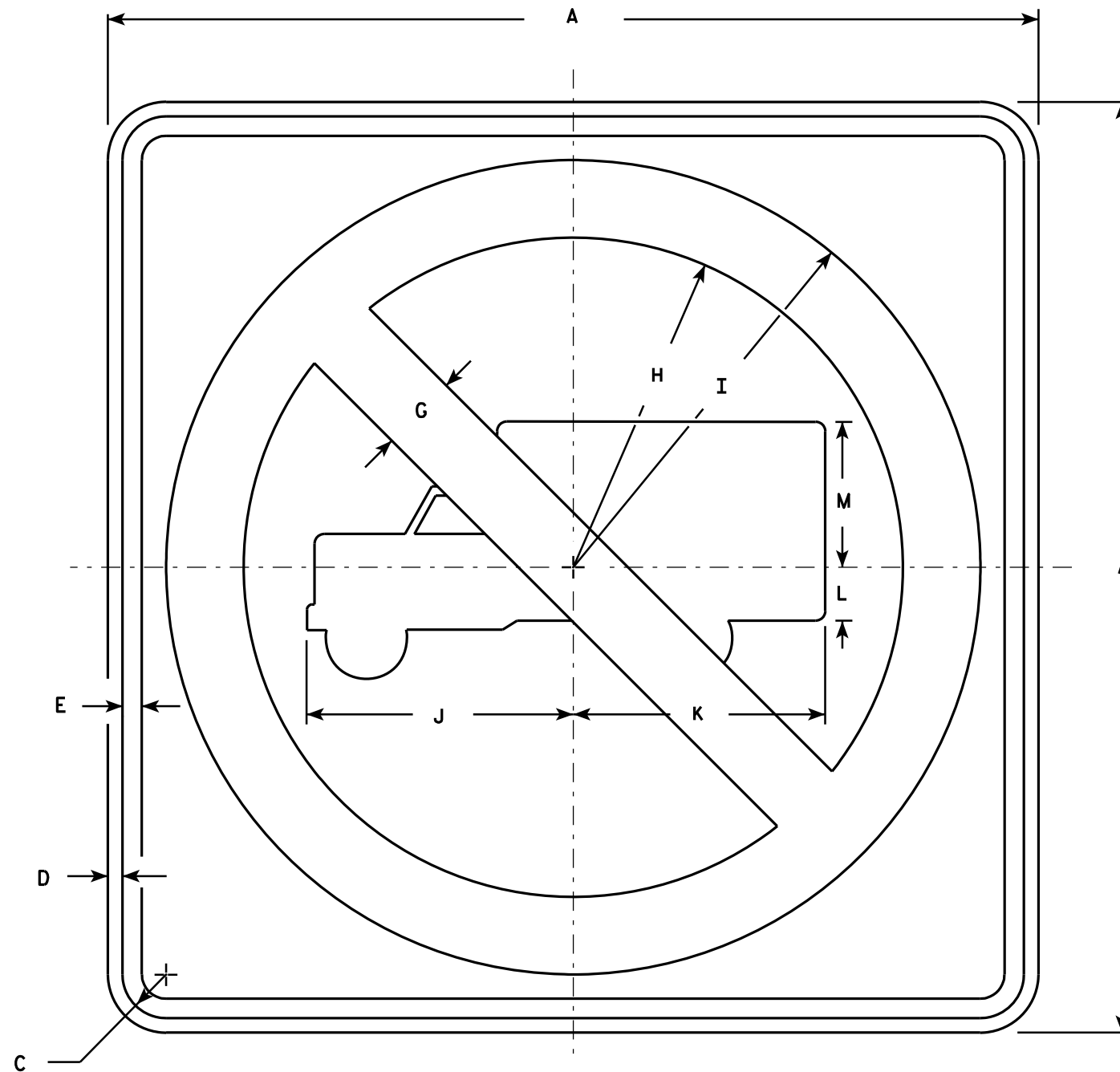

R5-2

SIZE	A	B	C	D	E	F	G	H	I	J	K	L	M	N	O	P	Q	R	S	T	U	V	W	X	Y	Z	Area sq. ft.
1																											
2S	24		1 1/8	3/8	1/2		2	8 1/2	10 1/2	6 7/8	6 1/2	1 3/8	3 3/4														4.0
2M	24		1 1/8	3/8	1/2		2	8 1/2	10 1/2	6 7/8	6 1/2	1 3/8	3 3/4														4.0
3	30		1 3/8	1/2	5/8		2 1/2	10 5/8	13 1/8	8 1/2	8 1/8	1 5/8	4 3/4														6.25
4	36		1 5/8	5/8	3/4		3	12 3/4	15 3/4	10 1/4	9 3/4	2	5 3/4														9.0
5	48		2 1/4	3/4	1		4	17	21	13 5/8	13	2 5/8	7 5/8														16.0

**STANDARD SIGN
R5-2**

WISCONSIN DEPT OF TRANSPORTATION
 APPROVED *Matthew R. Rauch*
 for State Traffic Engineer
 DATE 3/29/2011 PLATE NO. R5-2.6

PROJECT NO: _____ HWY: _____ COUNTY: _____ SHEET NO: **E**

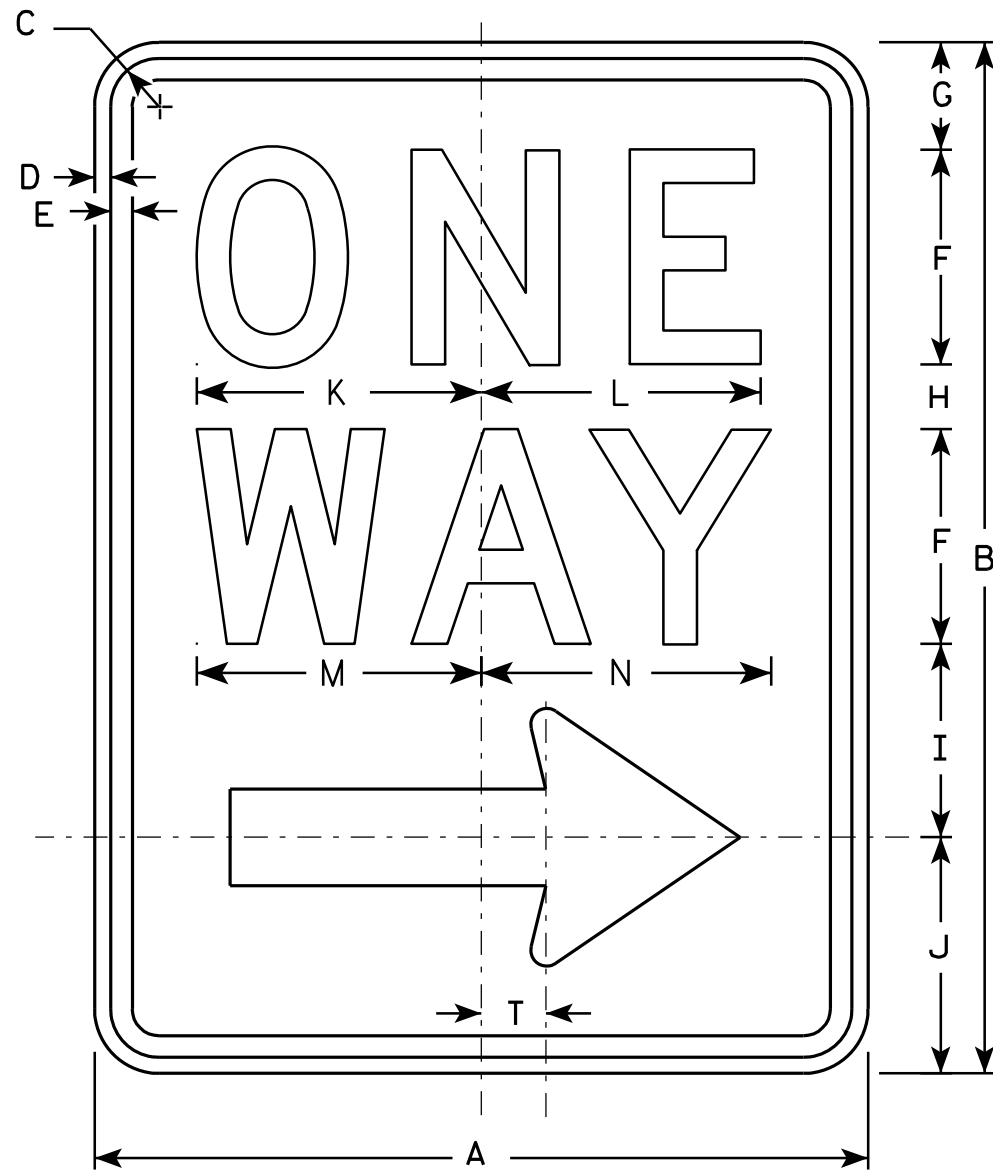

R6-2R

NOTES

1. Sign is Type II - Type H Reflective - reference WIS DOT Standard Specification for HIGHWAY and STRUCTURE CONSTRUCTION latest edition.
2. Color:
Background - White
Message - Black
3. Message Series - D
4. Corners may be square or rounded when base material is plywood but borders shall be rounded as shown. When base material is metal, the corners and borders shall be rounded.
5. R6-2L same as R6-2R except arrow points to the left.

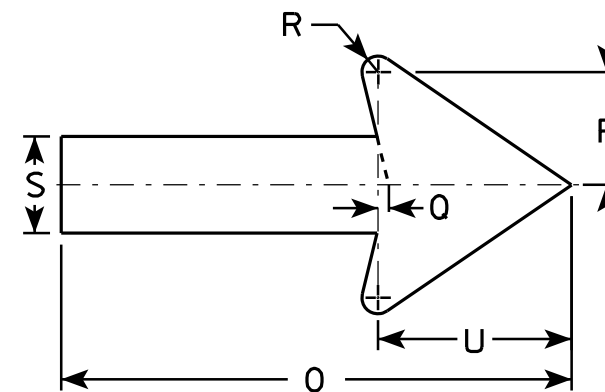

7

7

SIZE	A	B	C	D	E	F	G	H	I	J	K	L	M	N	O	P	Q	R	S	T	U	V	W	X	Y	Z
1	18	24	1 1/8	3/8	1/2	5	2 1/2	1 1/2	4 1/2	5 1/2	6 5/8	6 1/2	6 5/8	6 3/4	11 7/8	2 5/8	1/4	3/8	2 1/4	1 1/2	4 1/2					
2S	24	30	1 1/8	3/8	1/2	6	3	2 1/2	5 1/2	7	8 1/8	8 1/8	8 1/2	8 5/8	16	3 1/2	3/8	1/2	3	2	6					
2M	30	36	1 3/8	1/2	5/8	8	2 1/2	2 5/8	6 7/8	8	10 1/2	10 1/2	11 1/4	11 1/4	20	4 3/8	1/2	5/8	3 3/4	2 1/2	7 1/2					
3	36	48	1 7/8	1/2	5/8	10	5 1/4	3 1/4	9	10 1/2	12 3/4	12 3/4	13 1/4	13 1/2	24	5 5/8	1/2	3/4	4 3/4	3	9					
4	36	48	1 7/8	1/2	5/8	10	5 1/4	3 1/4	9	10 1/2	12 3/4	12 3/4	13 1/4	13 1/2	24	5 5/8	1/2	3/4	4 3/4	3	9					
5																										

STANDARD SIGN
R6-2 R&L

WISCONSIN DEPT OF TRANSPORTATION

APPROVED *Matthew R. Rauch*
For State Traffic Engineer

DATE 11/2/10 PLATE NO. R6-2.8

PROJECT NO: _____ HWY: _____ COUNTY: _____ SHEET NO: **E**

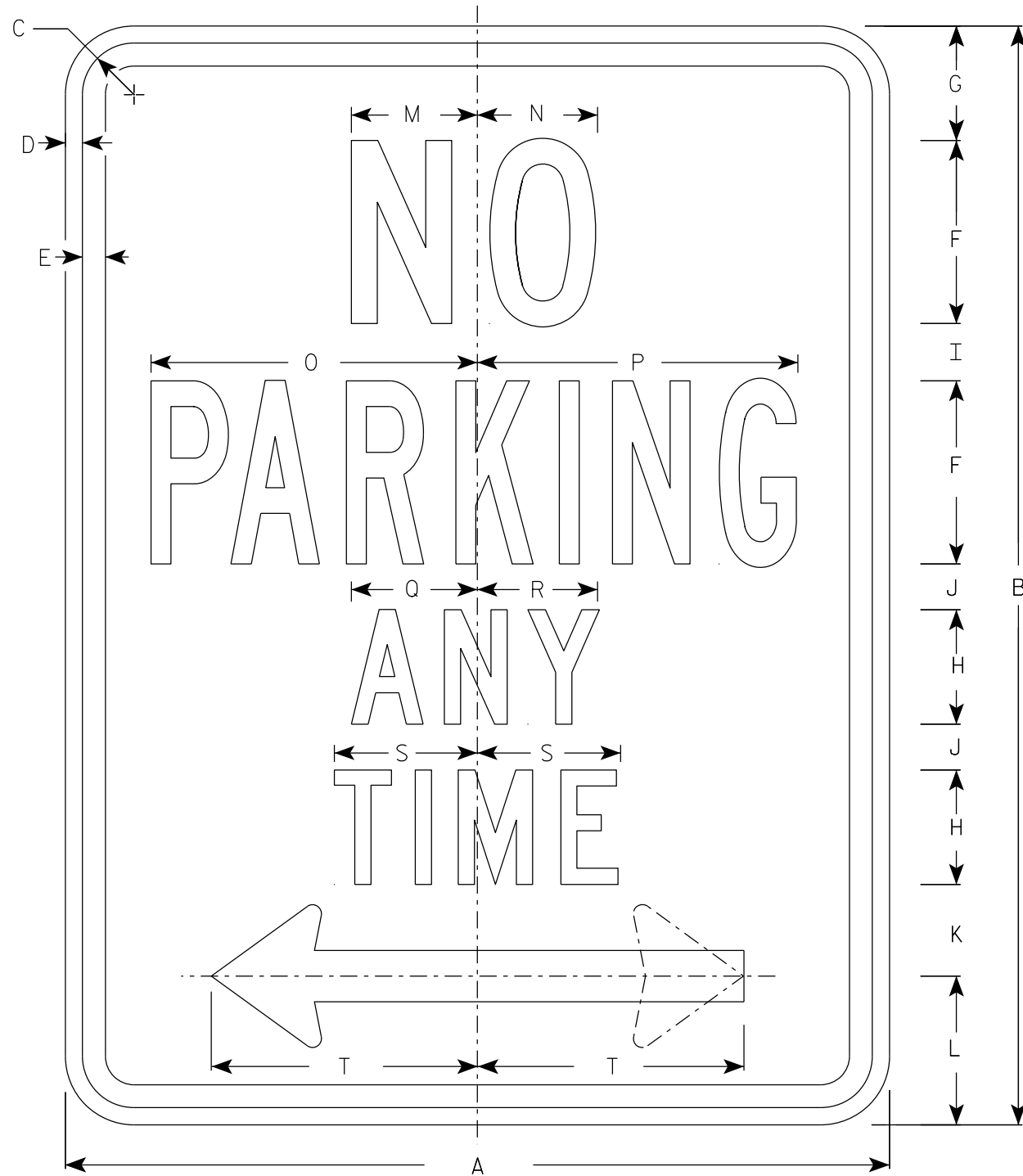

R7-1

NOTES

1. Sign is Type II - Type H Reflective
2. Color:
Background - White
Message - Red
3. Message Series - See Note 5
4. Lines 1, 3 and 4 are series C, line 2 is series B.
5. R7-1D (double arrow)
R7-1L (left arrow)
R7-1R (right arrow)

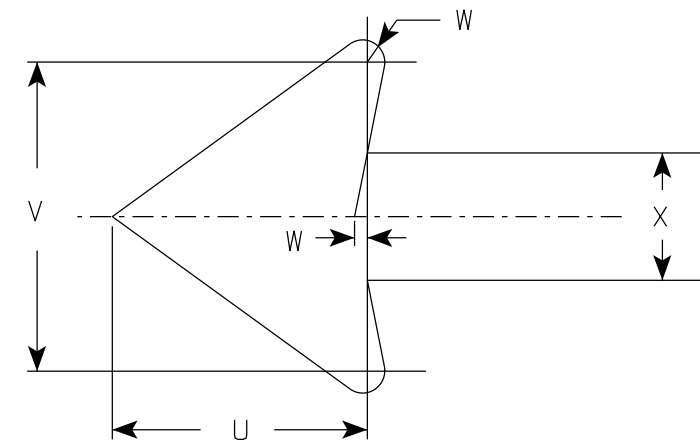

SIZE	A	B	C	D	E	F	G	H	I	J	K	L	M	N	O	P	Q	R	S	T	U	V	W	X	Y	Z	Area sq. ft.
1	12	18	1 1/8	3/8	3/8	3	1 7/8	2	7/8	5/8	1 1/2	2 1/2	2	2	4 7/8	4 7/8	2 1/4	2 1/8	2 1/2	3 7/8	1 1/2	1 3/4	1/8	3/4			1.5
2S	18	24	1 1/8	3/8	1/2	4	2 1/2	2 1/2	1 1/4	1	2	3 1/4	2 3/4	2 5/8	7 1/8	7	2 3/4	2 5/8	3 1/8	5 7/8	2 1/4	2 5/8	1/4	1 1/8			3.0
2M	24	30	1 1/8	3/8	1/2	5	3	3	2	1 1/4	2 1/2	4	3 1/4	3 3/8	9 1/4	9 1/4	3 1/4	3 1/4	3 3/4	7 3/4	3	3 1/2	1/4	1 1/2			5.0
3	24	30	1 1/8	3/8	1/2	5	3	3	2	1 1/4	2 1/2	4	3 1/4	3 3/8	9 1/4	9 1/4	3 1/4	3 1/4	3 3/4	7 3/4	3	3 1/2	1/4	1 1/2			5.0
4																											
5																											

STANDARD SIGN
R7-1

WISCONSIN DEPT OF TRANSPORTATION

APPROVED *Matthew R Rauch*
For State Traffic Engineer

DATE 3/31/2021 PLATE NO. R7-1.10

NOTES

1. Sign is Type II - Type H Reflective - reference WIS DOT Standard Specification for HIGHWAY and STRUCTURE CONSTRUCTION latest edition.
2. Color:
Background - Sign is white Type H Reflective; paraplegic background is blue.
Message - Legend and border are green; paraplegic symbol is white
3. Message Series - Lines 1 & 2 are Series B
Lines 3, 4, 5 & 6 are Series C
4. Corners may be square or rounded when base material is plywood but borders shall be rounded as shown. When base material is metal, the corners and borders shall be rounded.
5. R7-8R (RIGHT ARROW)
R7-8L (LEFT ARROW)

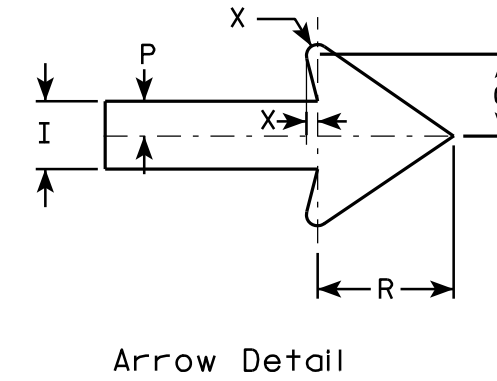
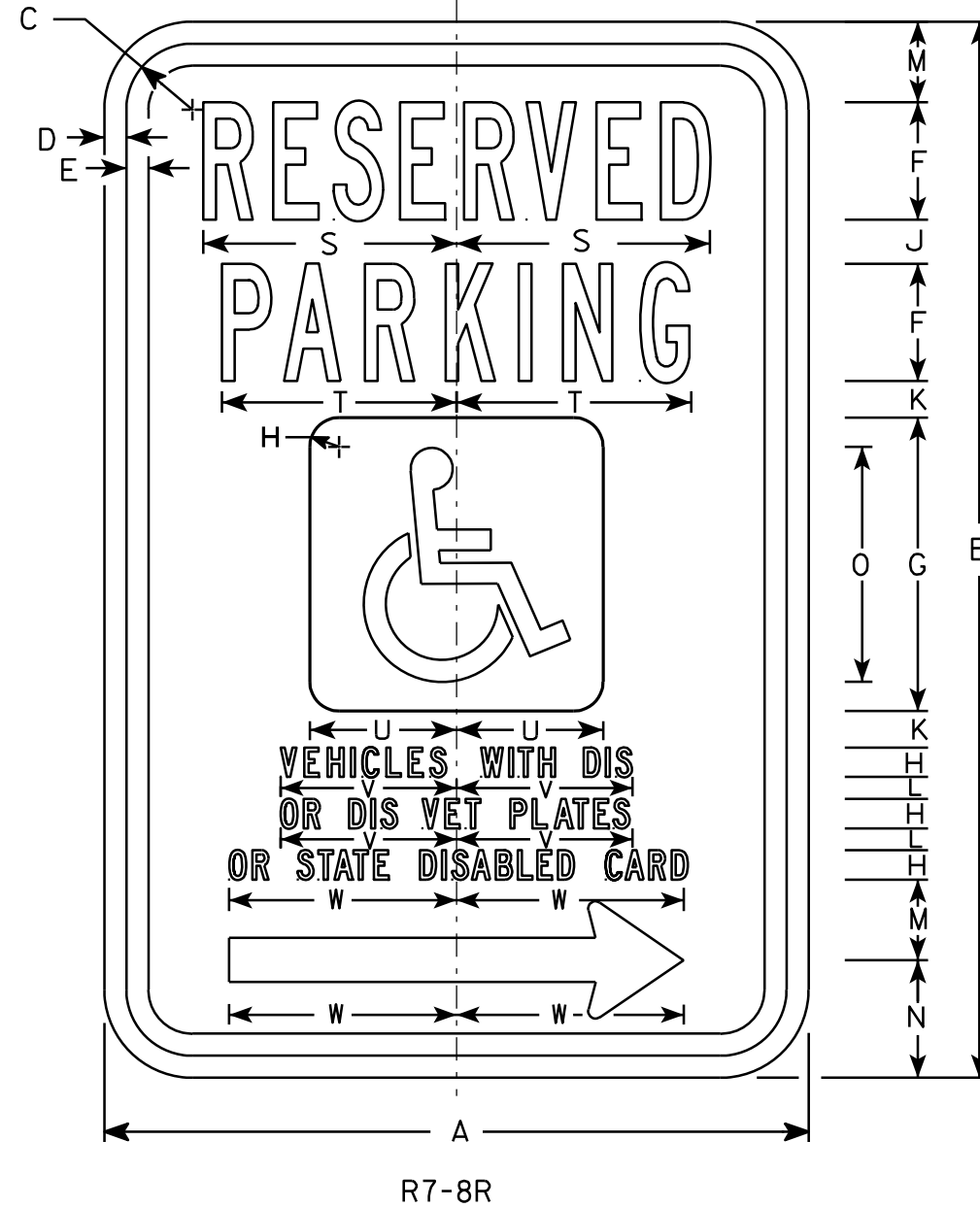

SIZE	A	B	C	D	E	F	G	H	I	J	K	L	M	N	O	P	Q	R	S	T	U	V	W	X	Y	Z	Area sq. ft.
1																											
2S	12	18	1 1/8	3/8	3/8	2	5	1/2	3/4	3/4	5/8	3/8	1 3/8	2	4	3/8	7/8	1 1/2	4 3/8	4	2 1/2	3	3 7/8	3/16		1.5	
2M	18	24	1 1/8	3/8	1/2	3	6	3/4	1 1/8	7/8	5/8	1/2	1 7/8	2 7/8	5	5/8	1 3/8	2 1/4	6 1/2	5 3/8	3	4 1/2	5 7/8	1/8		3.0	
3	18	24	1 1/8	3/8	1/2	3	6	3/4	1 1/8	7/8	5/8	1/2	1 7/8	2 7/8	5	5/8	1 3/8	2 1/4	6 1/2	5 3/8	3	4 1/2	5 7/8	1/8		3.0	
4																											
5																											

STANDARD SIGN
R7-8

WISCONSIN DEPT OF TRANSPORTATION

APPROVED *Matthew R. Rauch*
for State Traffic Engineer

DATE 3/31/2011 PLATE NO. R7-8.6

PROJECT NO: _____ HWY: _____ COUNTY: _____ SHEET NO: **E**

NOTES

1. Sign is Type II - Type H Reflective - reference WIS DOT Standard Specification for HIGHWAY and STRUCTURE CONSTRUCTION latest edition.
2. Color:
Background - White
Message - Black
3. Message Series - C
4. Corners may be square or rounded when base material is plywood but borders shall be rounded as shown. When base material is metal, the corners and borders shall be rounded.
5. Use Size 2 for Sidewalks. Use Size 3 for Paths and Trails.

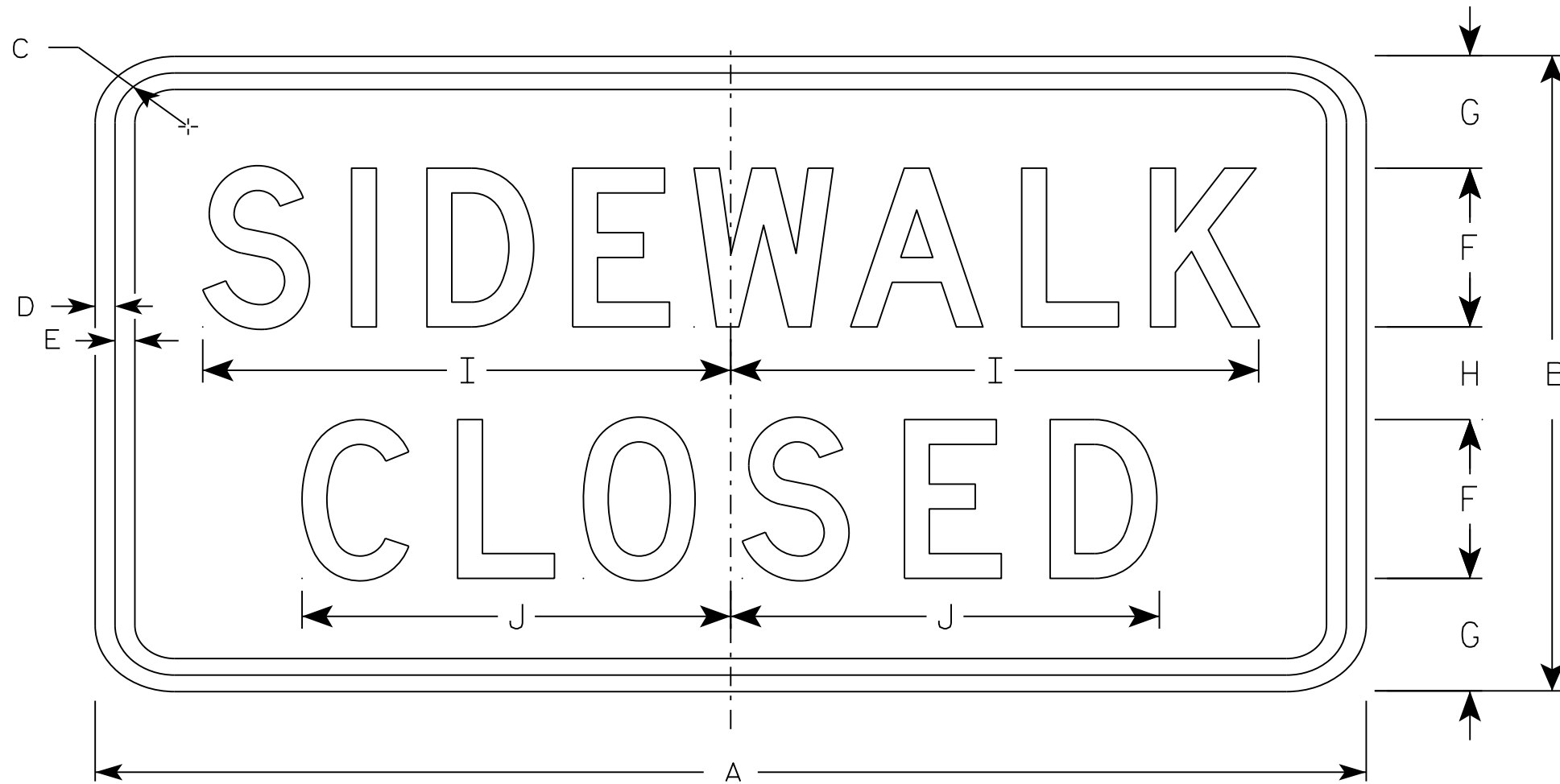

R9-9

7

SIZE	A	B	C	D	E	F	G	H	I	J	K	L	M	N	O	P	Q	R	S	T	U	V	W	X	Y	Z	Area sq. ft.
1																											
2S	24	12	1 3/4	1/2	1/2	3	2 1/8	1 3/4	10	8 1/8																	2.0
2M	24	12	1 3/4	1/2	1/2	3	2 1/8	1 3/4	10	8 1/8																	2.0
3	30	18	1 3/4	1/2	1/2	4	3 1/2	3	12 1/2	10 1/4																	3.75
4																											
5																											

STANDARD SIGN
R9-9

WISCONSIN DEPT OF TRANSPORTATION

APPROVED *Matthew R. Rauch*
For State Traffic Engineer

DATE 8/11/16 PLATE NO. R9-9.6

NOTES

1. Sign is Type II - Type H Reflective
2. Color:
Background - White
Message - Black
3. Message Series - D
4. Corners may be square or rounded when base material is plywood but borders shall be rounded as shown. When base material is metal, the corners and borders shall be rounded.

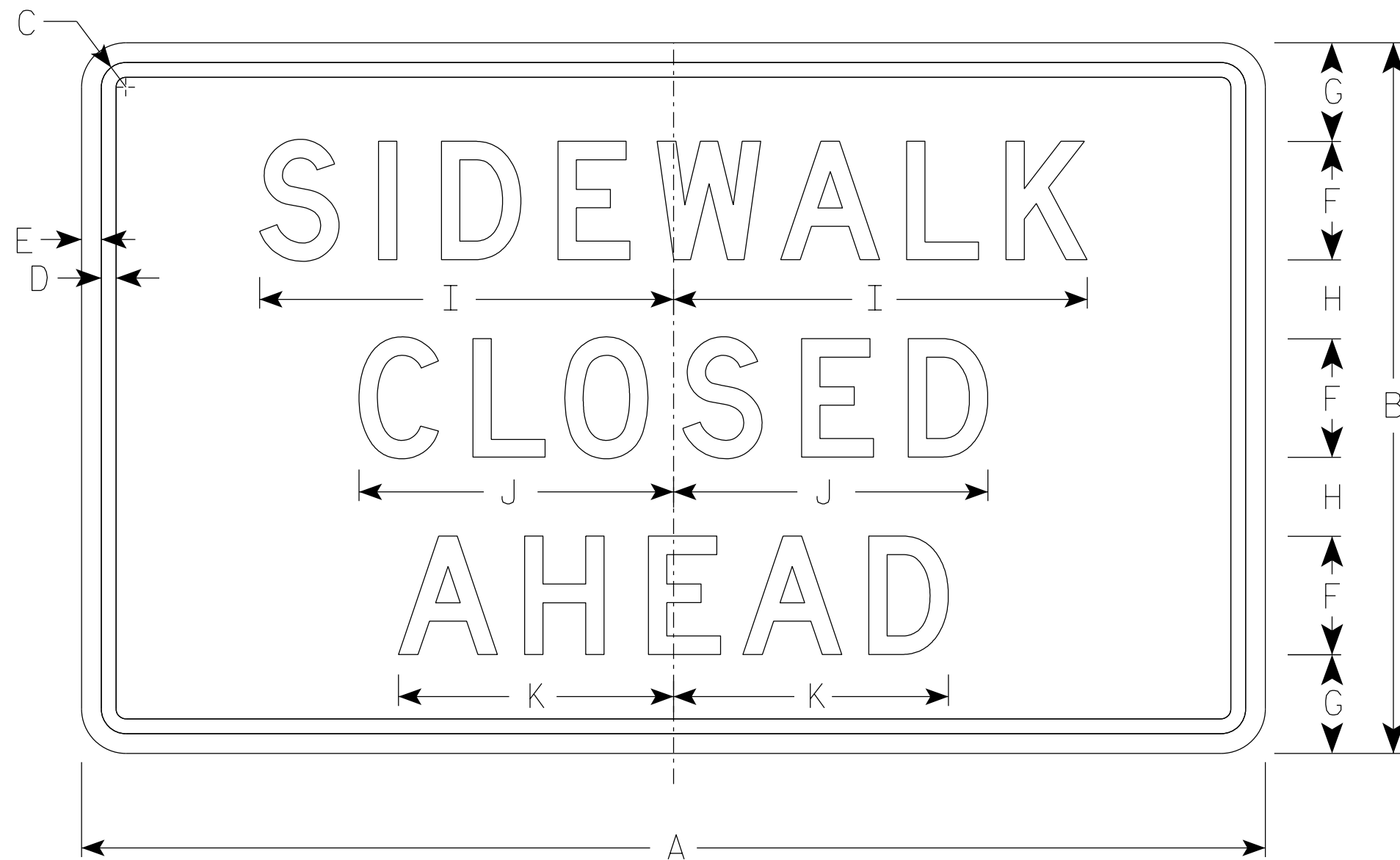

R9-9A

SIZE	A	B	C	D	E	F	G	H	I	J	K	L	M	N	O	P	Q	R	S	T	U	V	W	X	Y	Z	Area sq. ft.
1																											
2S	30	18	1 1/8	3/8	1/2	3	2 1/2	2	10 1/2	8	7																3.75
2M	30	18	1 1/8	3/8	1/2	3	2 1/2	2	10 1/2	8	7																3.75
3																											
4																											
5																											

STANDARD SIGN
R9-9A

WISCONSIN DEPT OF TRANSPORTATION

APPROVED *Matthew R. Rauch*
For State Traffic Engineer

DATE 8/31/2020 PLATE NO. R9-9A.1

PROJECT NO: _____ HWY: _____ COUNTY: _____ SHEET NO: **E**

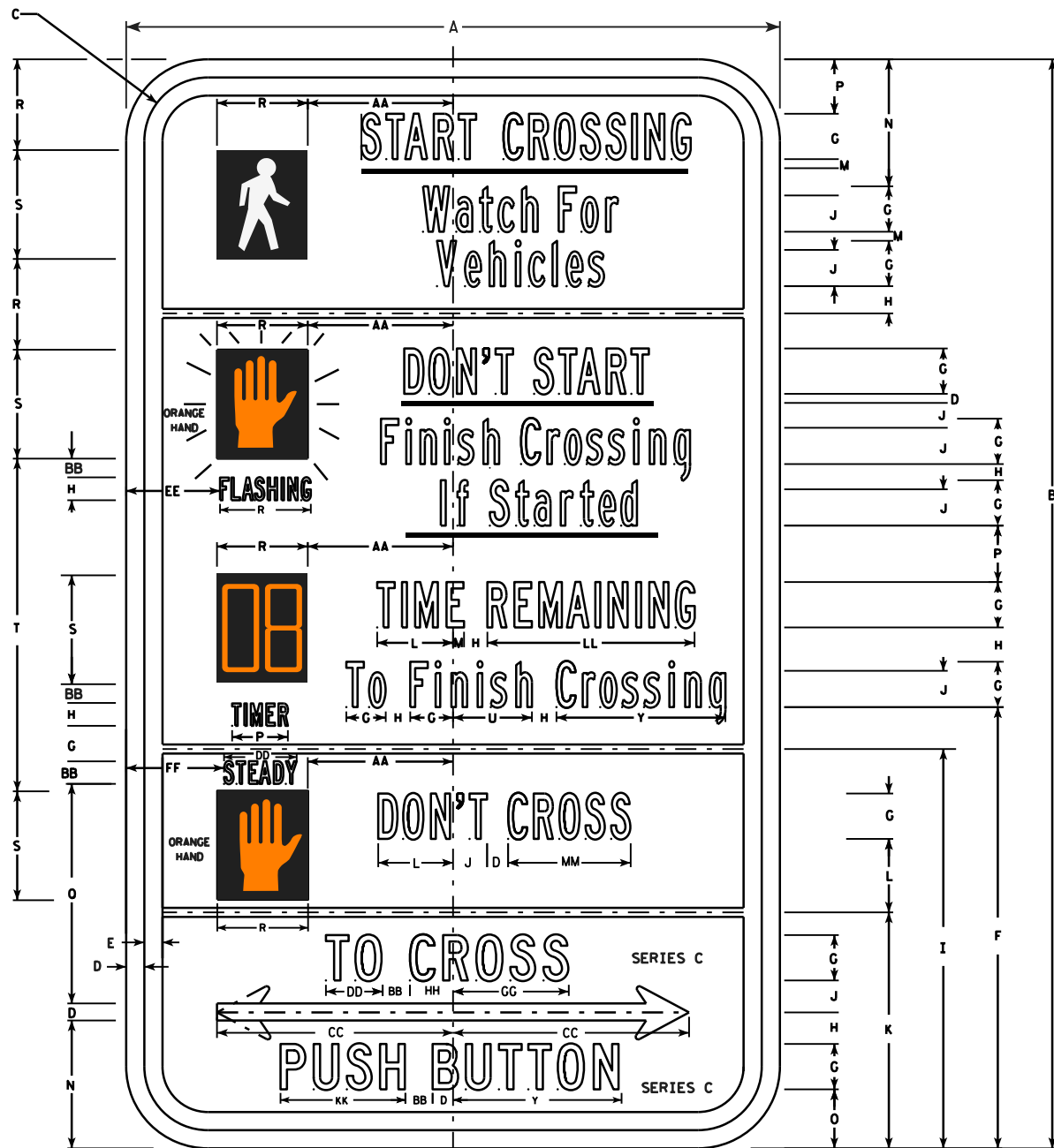

R10-3E

NOTES

1. All Signs Type II - Type H Reflective - reference WIS DOT Standard Specification for HIGHWAY and STRUCTURE CONSTRUCTION latest edition.
2. Color:
Background - WHITE
Message - BLACK except Hand Symbol which is Orange with black background.
3. Message Series - B or as noted on the sign.
4. R10-3ER (right arrow)
R10-3EL (left arrow)
R10-3ED (double arrow)

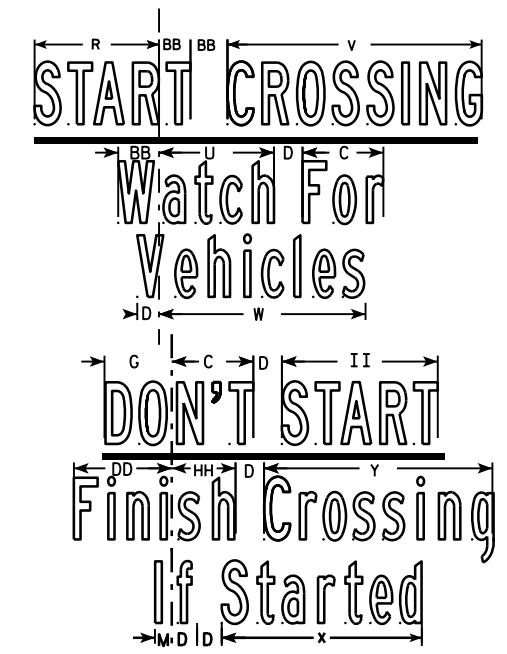

7

7

SIZE	A	B	C	D	E	F	G	H	I	J	K	L	M	N	O	P	Q	R	S	T	U	V	W	X	Y	Z	Area sq. ft.
1	6	10	1/2	1/8	1/8	4	3/8	1/4	4 1/8	1/4	2 1/8	3/4	1/8	1 1/8	1/2	1/2	2 1/4	7/8	1	3	3/4	1 3/4	1 5/8	1 3/8	1 1/2	5/8	0.42
2S	9	15	7/8	1/4	1/4	6 1/8	5/8	3/8	5 1/2	1/2	3 1/4	1	1/8	1 3/4	7/8	3/4	3	1 1/4	1 1/2	4 5/8	1 1/8	2 5/8	2 1/8	2	2 3/8	1 3/8	0.94
2M	9	15	7/8	1/4	1/4	6 1/8	5/8	3/8	5 1/2	1/2	3 1/4	1	1/8	1 3/4	7/8	3/4	3	1 1/4	1 1/2	4 5/8	1 1/8	2 5/8	2 1/8	2	2 3/8	1 3/8	0.94
3																											
4																											

SIZE	AA	BB	CC	DD	EE	FF	GG	HH	II	JJ	KK	LL	MM	NN	OO	PP	QQ	RR	SS	TT	UU	VV	WW	XX	YY	ZZ	Area sq. ft.
1	1 3/8	1/4	2 1/4	1/2	7/8	7/8	1 1/8	3/8	1	1/2	1 1/8	1 7/8	1 1/8														
2S	2	3/8	3 1/4	1	1 1/4	1 3/8	1 5/8	5/8	1 5/8	3/4	1 3/4	2 7/8	1 5/8														
2M	2	3/8	3 1/4	1	1 1/4	1 3/8	1 5/8	5/8	1 5/8	3/4	1 3/4	2 7/8	1 5/8														
3																											
4																											

STANDARD SIGN
R10-3EL,R,D

WISCONSIN DEPT OF TRANSPORTATION

APPROVED *Matthew R. Rauch*
for State Traffic Engineer

DATE 4/12/2011 PLATE NO. R10-3E.2

NOTES

1. Sign is Type II - Type H Reflective - reference WIS DOT Standard Specification for HIGHWAY and STRUCTURE CONSTRUCTION latest edition.
2. Color:
Background - White
Message - Black
3. Message Series - See Note 5
4. Corners may be square or rounded when base material is plywood but borders shall be rounded as shown. When base material is metal, the corners and borders shall be rounded.
5. Line 1 is Series E.
Lines 2 thru 6 are Series D.

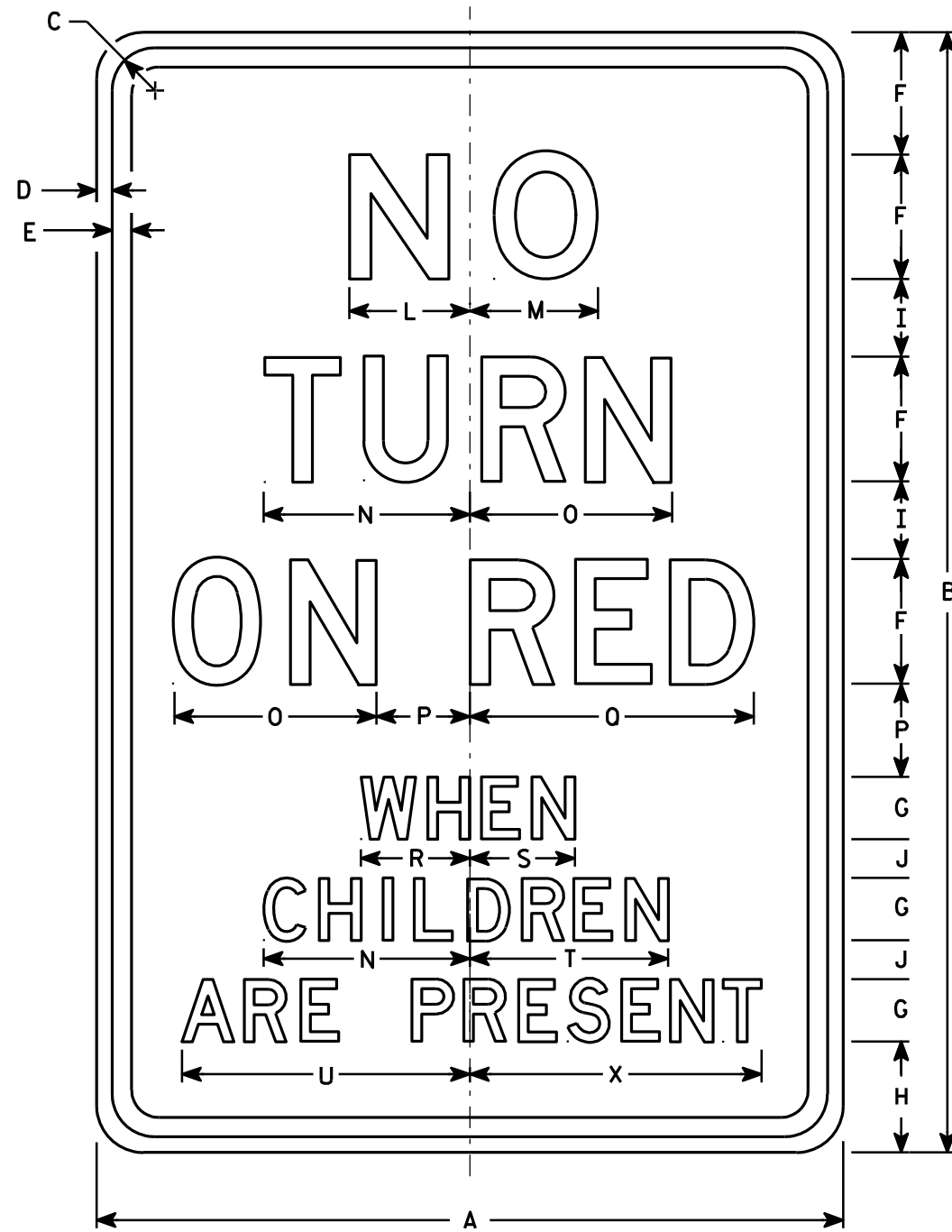

R10-11S

SIZE	A	B	C	D	E	F	G	H	I	J	K	L	M	N	O	P	Q	R	S	T	U	V	W	X	Y	Z	Area sq. ft.
1																											
2S	24	36	1 1/8	3/8	1/2	4	2	3 1/2	2 1/2	1 1/4	4 1/2	3 7/8	4 1/8	6 5/8	6 1/2	3	9 1/8	3 1/2	3 3/8	6 3/8	9 1/4			9 3/8		6.0	
2M	24	36	1 1/8	3/8	1/2	4	2	3 1/2	2 1/2	1 1/4	4 1/2	3 7/8	4 1/8	6 5/8	6 1/2	3	9 1/8	3 1/2	3 3/8	6 3/8	9 1/4			9 3/8		6.0	
3																											
4																											
5																											

STANDARD SIGN
R10-11S

WISCONSIN DEPT OF TRANSPORTATION

APPROVED _____
State Traffic Engineer

DATE 4/4/11 PLATE NO. R10-11S.5

PROJECT NO: _____ HWY: _____ COUNTY: _____ SHEET NO: _____ **E**

NOTES

1. Sign is Type II - Type H Reflective - reference WIS DOT Standard Specification for HIGHWAY and STRUCTURE CONSTRUCTION latest edition.
2. Color:
Background - White
Message - Black
3. Message Series - C
4. Corners may be square or rounded when base material is plywood but borders shall be rounded as shown. When base material is metal, the corners and borders shall be rounded.

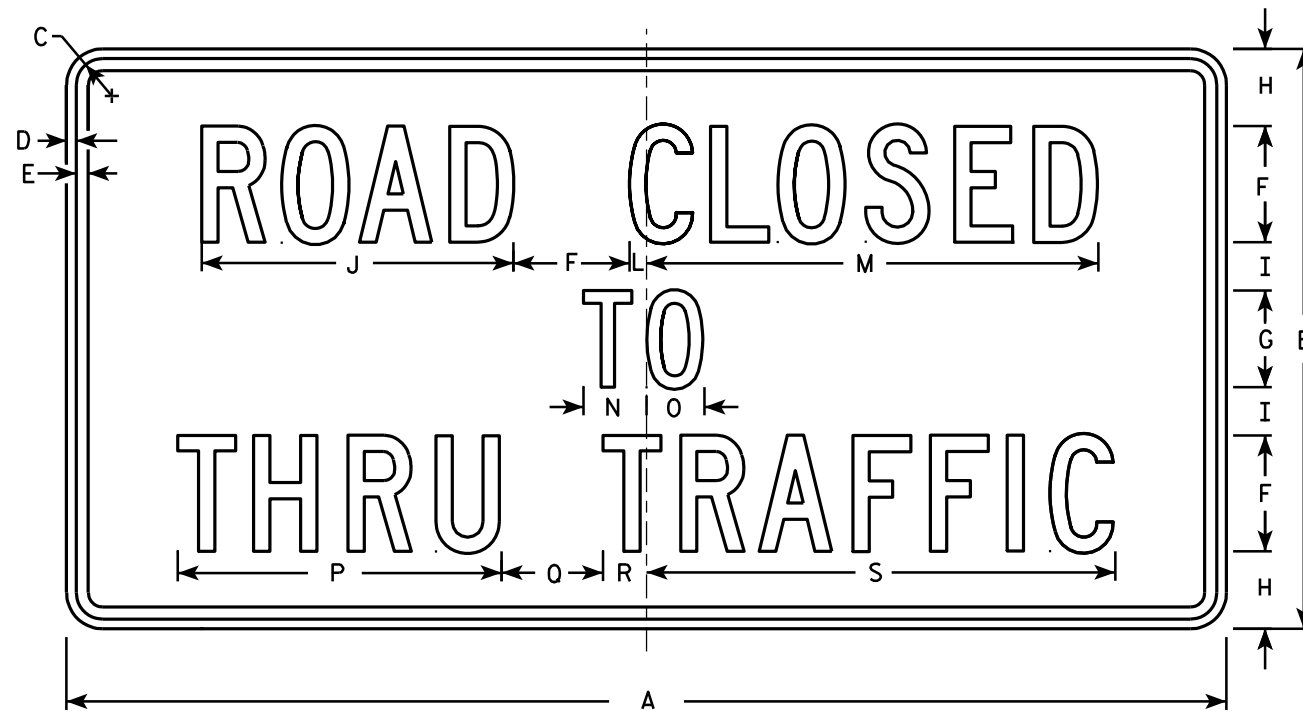

R11-4

7

7

SIZE	A	B	C	D	E	F	G	H	I	J	K	L	M	N	O	P	Q	R	S	T	U	V	W	X	Y	Z	Area sq. ft.
1																											
2S	60	30	1 3/8	1/2	5/8	6	5	4	2 1/2	16 1/8		7/8	23 3/8	3 1/4	3	16 3/4	5 1/4	2 1/4	24 1/4								12.5
2M	60	30	1 3/8	1/2	5/8	6	5	4	2 1/2	16 1/8		7/8	23 3/8	3 1/4	3	16 3/4	5 1/4	2 1/4	24 1/4								12.5
3																											
4																											
5																											

STANDARD SIGN
R11 - 4

WISCONSIN DEPT OF TRANSPORTATION

APPROVED *Matthew R. Raush*
for State Traffic Engineer

DATE 4/1/11 PLATE NO. R11-4.3

PROJECT NO: _____ HWY: _____ COUNTY: _____ SHEET NO: _____ E

NOTES

1. Sign is Type II - Type H Reflective - reference WIS DOT Standard Specification for HIGHWAY and STRUCTURE CONSTRUCTION latest edition.
2. Color:
Background - White
Message - Black
3. Message Series - See note 5
4. Corners may be square or rounded when base material is plywood but borders shall be rounded as shown. When base material is metal, the corners and borders shall be rounded.
5. Lines 1, 2 & 3 are series E
Lines 4, 5, & 6 are series D.
6. Substitute appropriate numeral and optically adjust spacing to achieve proper balance.
7. Substitute name of county or town on County Trunk and Town Highways respectively. Community name on City or Village Streets including Connecting Highways is optional.

* Varies (see note 6)

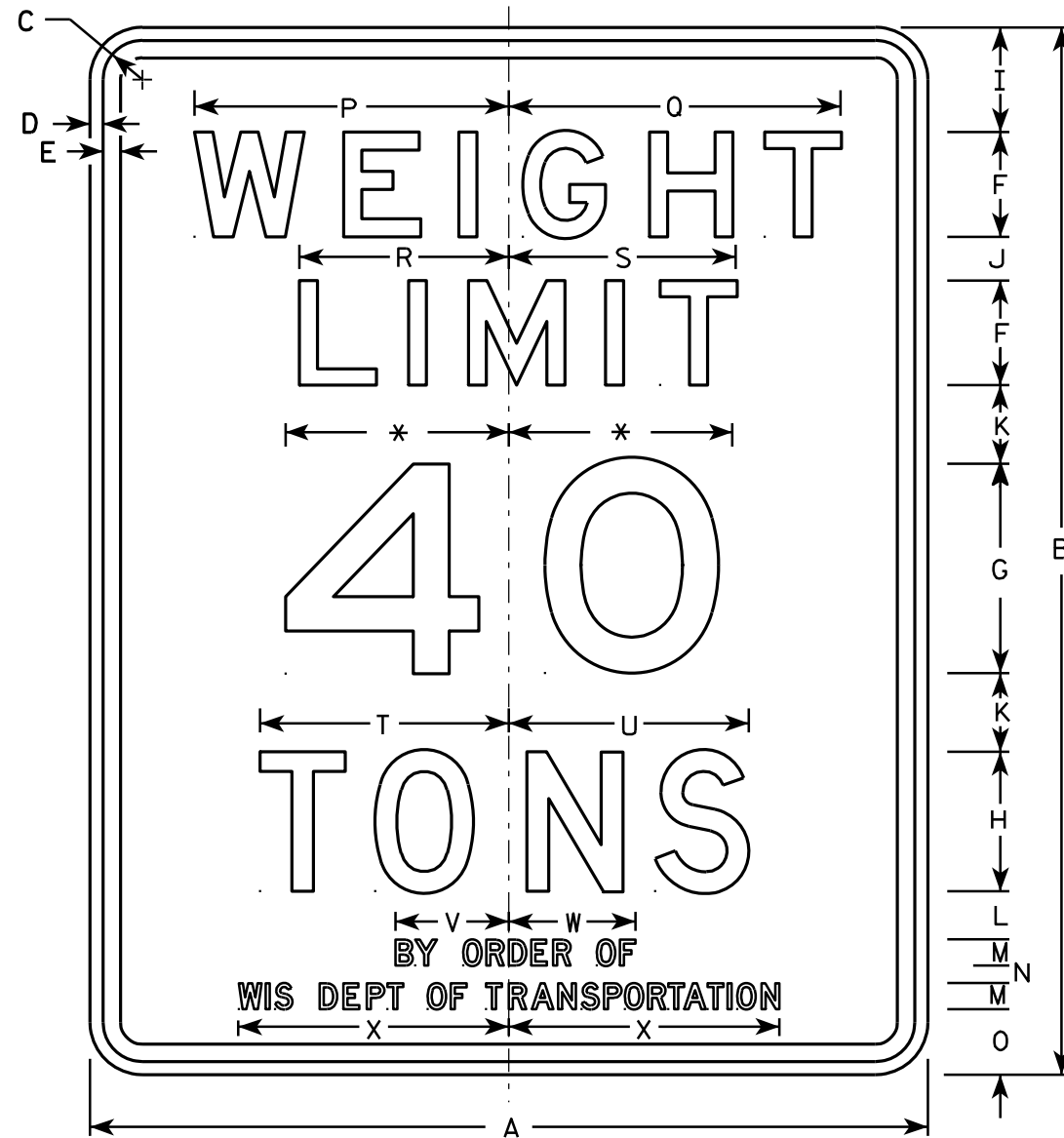

R12-1

7

7

SIZE	A	B	C	D	E	F	G	H	I	J	K	L	M	N	O	P	Q	R	S	T	U	V	W	X	Y	Z	Area sq. ft.
1	24	30	1 1/8	3/8	1/2	3	6	4	3	1 1/4	2 1/4	1 3/8	3/4	1/2	1 7/8	9	9 1/2	6	6 1/2	7 1/8	6 7/8	3 1/4	3 5/8	7 3/4			5.0
2S	24	30	1 1/8	3/8	1/2	3	6	4	3	1 1/4	2 1/4	1 3/8	3/4	1/2	1 7/8	9	9 1/2	6	6 1/2	7 1/8	6 7/8	3 1/4	3 5/8	7 3/4			5.0
2M	24	30	1 1/8	3/8	1/2	3	6	4	3	1 1/4	2 1/4	1 3/8	3/4	1/2	1 7/8	9	9 1/2	6	6 1/2	7 1/8	6 7/8	3 1/4	3 5/8	7 3/4			5.0
3	36	48	1 3/8	1/2	5/8	6	10	8	4 1/2	2 1/2	2 1/4	1 1/2	3/4	1/2	3	13 1/2	14 1/4	9	9 3/4	10 5/8	10 1/4	3 1/4	3 5/8	7 3/4			12.0
4	48	60	2 1/4	3/4	1	6	12	8	6	2 1/2	4 1/2	2 3/4	1 1/2	1	3 3/4	18	19	12	13	14 1/4	13 3/4	6 1/2	7 1/4	15 1/2			20.0
5																											

STANDARD SIGN
R12-1

WISCONSIN DEPT OF TRANSPORTATION

APPROVED *Matthew R. Rauch*
for State Traffic Engineer

DATE 4/1/11 PLATE NO. R12-1.8

PROJECT NO: _____ HWY: _____ COUNTY: _____ SHEET NO: _____ E

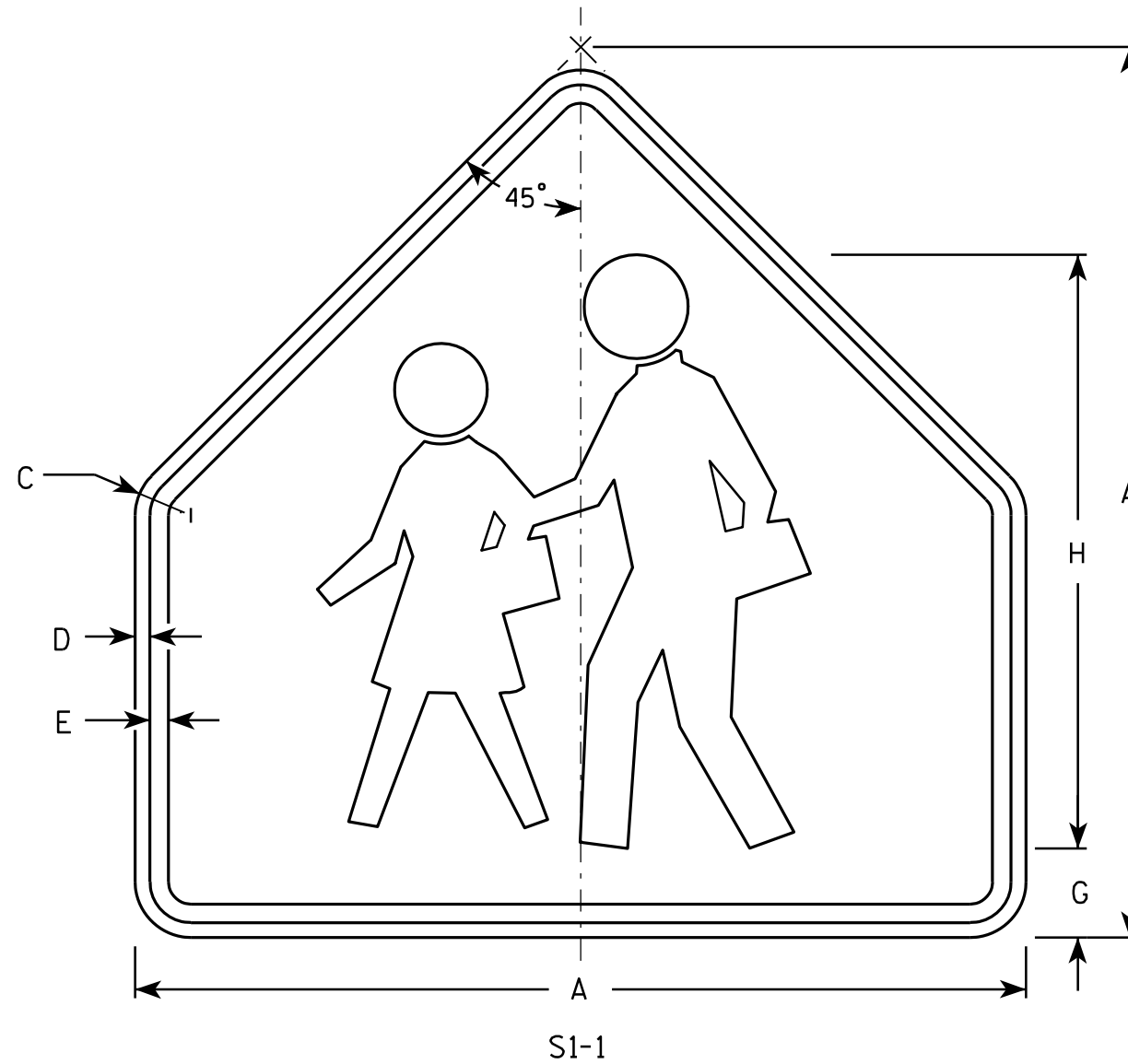

NOTES

1. Sign is Type II - Type F Reflective - reference WIS DOT Standard Specification for HIGHWAY and STRUCTURE CONSTRUCTION latest edition.
2. Color:
Background - Yellow-Green
Message - Black
3. Corners may be square or rounded when base material is plywood but borders shall be rounded as shown. When base material is metal, the corners and borders shall be rounded.

7

7

SIZE	A	B	C	D	E	F	G	H	I	J	K	L	M	N	O	P	Q	R	S	T	U	V	W	X	Y	Z	Area sq. ft.
1	30		1 3/8	1/2	5/8		3	20																			4.69
2	36		1 5/8	5/8	3/4		3 1/2	24																			6.75
3	36		1 5/8	5/8	3/4		3 1/2	24																			6.75
4	48		2 1/4	3/4	1		4 3/4	32																			12
5																											

STANDARD SIGN
S1-1

WISCONSIN DEPT OF TRANSPORTATION

APPROVED *Matthew R. Rauch*
for State Traffic Engineer

DATE 6/30/05 PLATE NO. S1-1.8

PROJECT NO: _____ HWY: _____ COUNTY: _____ SHEET NO: _____ E

NOTES

1. Sign is Type II - See Note 2 for Sheeting Type
2. Color:
Background - See Note 4
Message - Black
3. Message Series - See Note 5
4. Top panel (SCHOOL) background - Yellow Green - Type F Reflective
Lower panel background - White - Type SH Reflective
5. From top to bottom:
Lines 1, 5, 6 & 7 are series D
Lines 2, 3 & 4 are series E
6. Line 4 substitute appropriate numerals and adjust spacing to achieve proper balance.

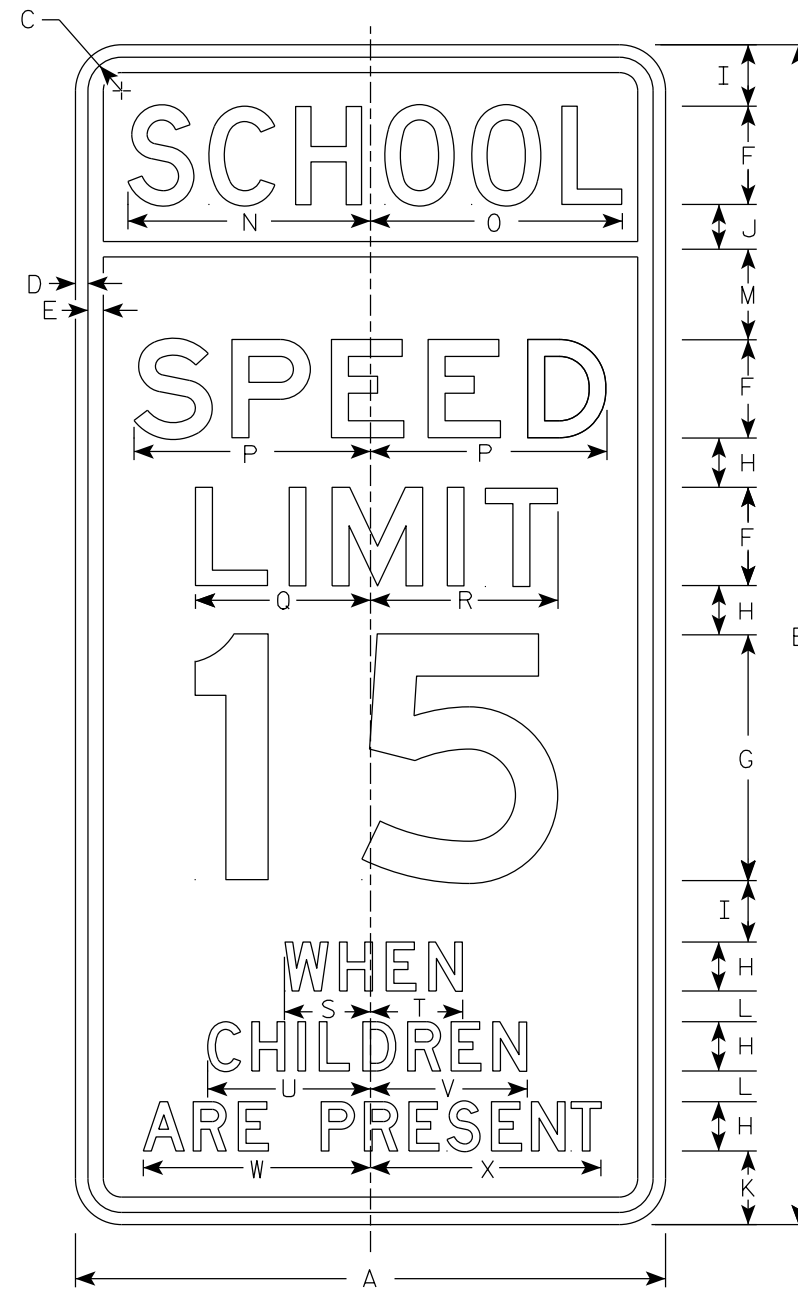

S4-51

SIZE	A	B	C	D	E	F	G	H	I	J	K	L	M	N	O	P	Q	R	S	T	U	V	W	X	Y	Z	Area sq. ft.
1																											
2	24	48	1 3/8	1/2	5/8	4	10	2	2 1/2	1 3/4	3	1 1/4	3 3/4	9 7/8	10 1/4	9 5/8	7 1/8	7 5/8	3 1/2	3 3/8	6 5/8	6 3/8	9 1/4	9 3/8			8.00
3	36	72	2 1/4	3/4	1	6	15	3	3 3/4	2 3/4	4 1/2	1 7/8	5 1/2	15	15 1/4	14 1/2	11 1/4	11 1/2	5 1/2	5 3/4	10	9 3/4	14	14 1/8			18.00
4																											
5																											

STANDARD SIGN
S4-51

WISCONSIN DEPT OF TRANSPORTATION

APPROVED *Matthew R. Rauch*
for State Traffic Engineer

DATE 7/27/2020 PLATE NO. S4-51.10

PROJECT NO: _____ HWY: _____ COUNTY: _____ SHEET NO: _____ **E**

NOTES

1. Sign is Type II - Type H Reflective - reference WIS DOT Standard Specification for HIGHWAY and STRUCTURE CONSTRUCTION latest edition.
2. Color:
Background - White
Message - Black
3. Message Series - C
4. Corners may be square or rounded when base material is plywood but borders shall be rounded as shown. When base material is metal, the corners and borders shall be rounded.

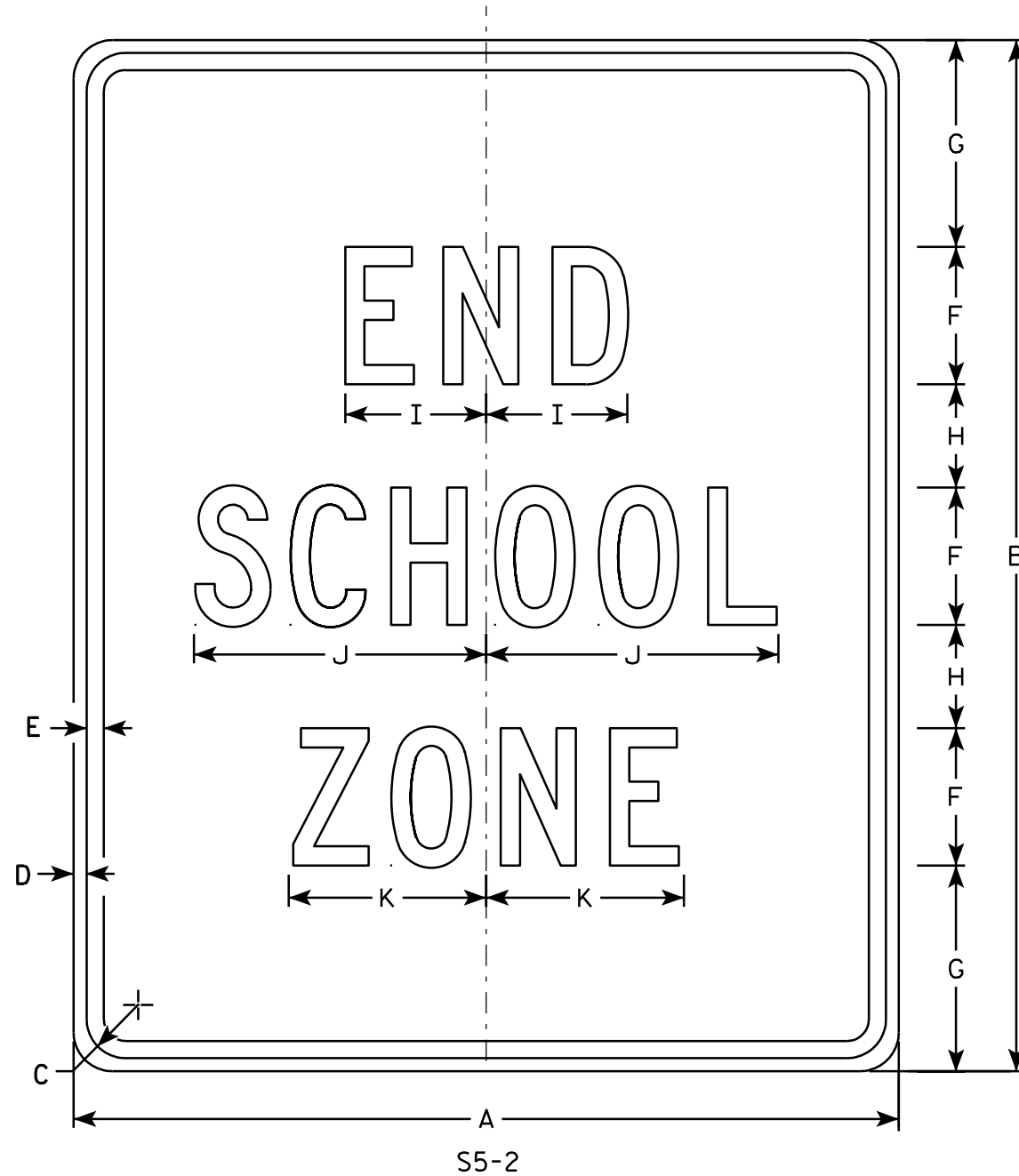

7

7

SIZE	A	B	C	D	E	F	G	H	I	J	K	L	M	N	O	P	Q	R	S	T	U	V	W	X	Y	Z	Area sq. ft.
1																											
2	24	30	1 1/8	3/8	1/2	4	6	3	4 1/8	8 1/2	5 3/4																5.0
3	36	42	1 5/8	5/8	3/4	6	7	5	6 1/8	12 5/8	8 5/8																10.5
4																											
5																											

STANDARD SIGN
S5-2

WISCONSIN DEPT OF TRANSPORTATION

APPROVED *Matthew R. Rauch*
For State Traffic Engineer

DATE 3/8/11 PLATE NO. S5-2.2

PROJECT NO: _____ HWY: _____ COUNTY: _____ SHEET NO: **E**

NOTES

1. Sign is Type II - Type F Reflective
2. Color:
Background - Yellow-Green
Message - Black
3. S16-7R are the same as S16-7L except the arrow is reversed along the vertical centerline.

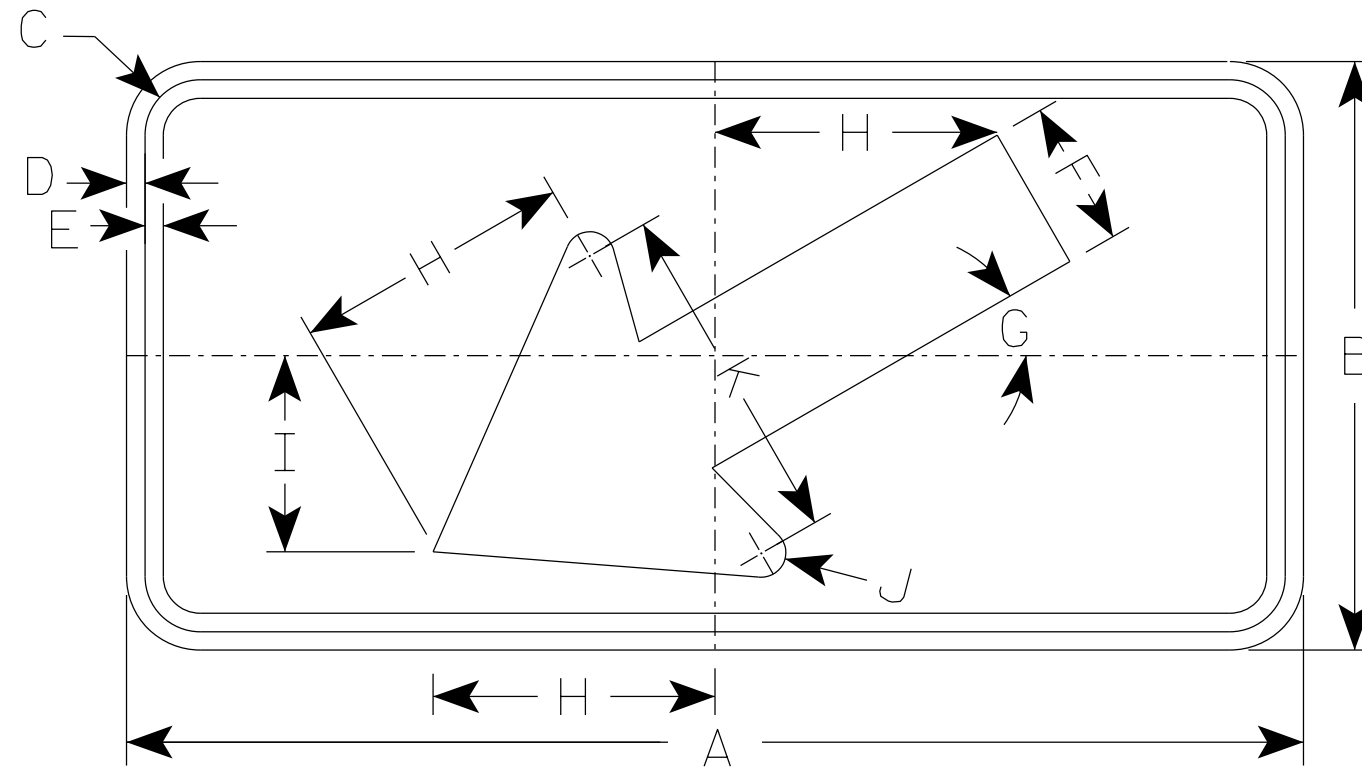

S16-7L

7

7

SIZE	A	B	C	D	E	F	G	H	I	J	K	L	M	N	O	P	Q	R	S	T	U	V	W	X	Y	Z	Area sq. ft.
1	24	12	1 1/8	3/8	3/8	3	30°	5 3/4	4	1/2	7																2.0
2S	30	18	1 1/8	3/8	1/2	4 1/2	30°	8 1/2	6	5/8	10 1/4																3.75
2M	30	18	1 1/8	3/8	1/2	4 1/2	30°	8 1/2	6	5/8	10 1/4																3.75
3	30	18	1 1/8	3/8	1/2	4 1/2	30°	8 1/2	6	5/8	10 1/4																3.75
4	48	24	1 3/8	1/2	5/8	6	30°	11 1/2	8	1	14																8.0
5																											

STANDARD SIGN
S16-7

WISCONSIN DEPT OF TRANSPORTATION

APPROVED *Matthew R Rauch*
For State Traffic Engineer

DATE 3/16/2021 PLATE NO. S16-7.2

PROJECT NO: _____ HWY: _____ COUNTY: _____ SHEET NO: _____ **E**

NOTES

1. Sign is Type II - Type F Reflective - reference WIS DOT Standard Specification for HIGHWAY and STRUCTURE CONSTRUCTION latest edition.
2. Color:
Background - Yellow-Green
Message - Black
3. Message Series - C
4. Corners may be square or rounded when base material is plywood but borders shall be rounded as shown. When base material is metal, the corners and borders shall be rounded.

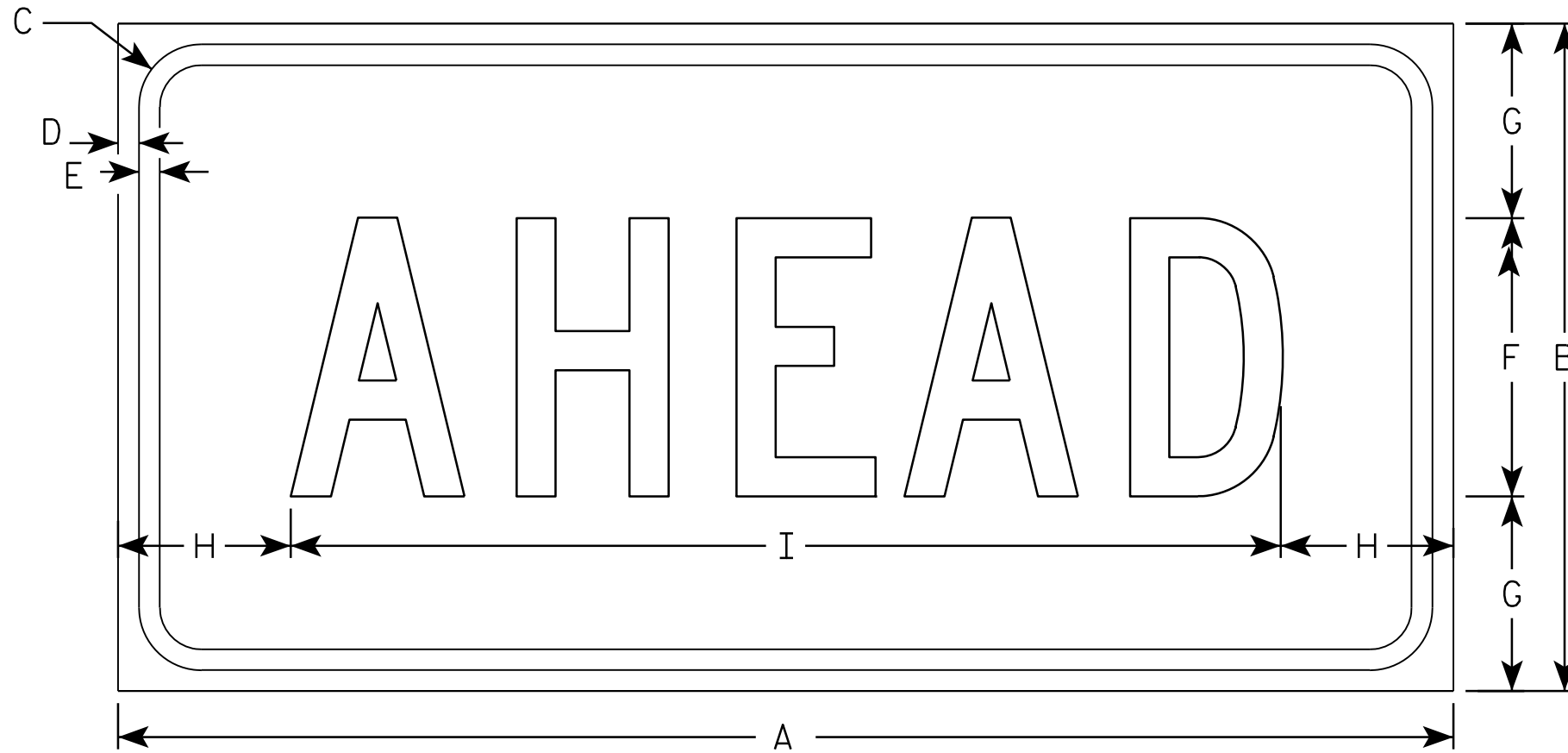

S16-9P

7

7

SIZE	A	B	C	D	E	F	G	H	I	J	K	L	M	N	O	P	Q	R	S	T	U	V	W	X	Y	Z	Area sq. ft.
1	24	12	1 1/8	3/8	3/8	5	3 1/2	3 1/8	17 3/4																		2.0
2S	30	18	1 1/8	3/8	1/2	7	5 1/2	2 3/4	24 1/2																		3.75
2M	30	18	1 1/8	3/8	1/2	7	5 1/2	2 3/4	24 1/2																		3.75
3	30	18	1 1/8	3/8	1/2	7	3 1/2	2 3/4	24 1/2																		3.75
4	48	24	1 3/8	1/2	5/8	10	7	6 1/8	35 3/4																		8.0
5																											

STANDARD SIGN
S16-9P

WISCONSIN DEPT OF TRANSPORTATION

APPROVED *Matthew R. Rauch*
for State Traffic Engineer

DATE 7/22/13 PLATE NO. S16-9P.1

PROJECT NO: _____ HWY: _____ COUNTY: _____ SHEET NO: _____ E

TRAFFIC FROM LEFT

W4-4AL

NOTES

1. Sign is Type II - Type F Reflective - reference WIS DOT Standard Specification for HIGHWAY and STRUCTURE CONSTRUCTION latest edition.
2. Color:
Background - Yellow
Message - Black
3. Message Series - B
4. Corners may be square or rounded when base material is plywood but borders shall be rounded as shown. When base material is metal, the corners and borders shall be rounded.

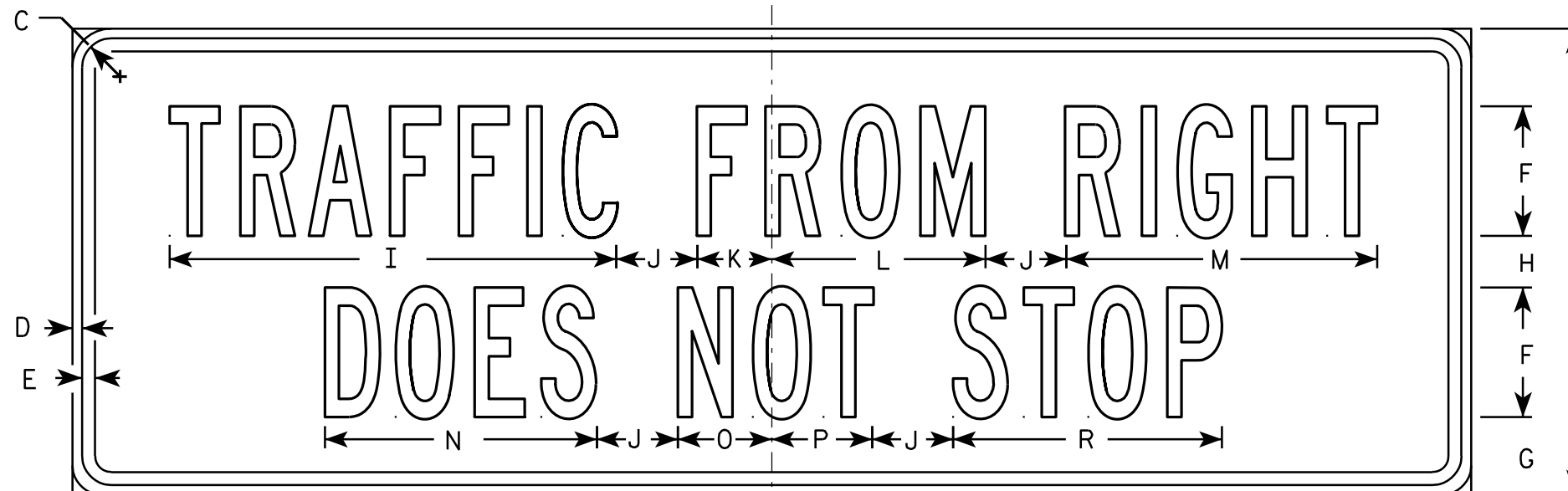

W4-4AR

7

7

SIZE	A	B	C	D	E	F	G	H	I	J	K	L	M	N	O	P	Q	R	S	T	U	V	W	X	Y	Z	Area sq. ft.
1																											
2S	30	12	1 1/8	3/8	3/8	3	2 1/4	1 1/2	10 3/8	1 1/2	1 3/4	4 7/8	7 1/4	6 1/4	2 1/4	2 1/4		6 1/4	1	5 5/8	5 3/4						2.5
2M	30	12	1 1/8	3/8	3/8	3	2 1/4	1 1/2	10 3/8	1 1/2	1 3/4	4 7/8	7 1/4	6 1/4	2 1/4	2 1/4		6 1/4	1	5 5/8	5 3/4						2.5
3	42	15	1 1/8	3/8	1/2	4	2 5/8	1 3/4	13 7/8	2 3/8	2 1/8	6 3/4	9 3/4	8 3/8	2 3/4	3 3/8		8 3/8	1 1/8	7 3/4	7 3/4						4.4
4	54	18	1 1/8	3/8	1/2	5	3	2	17 1/4	3 1/8	2 7/8	8 1/4	12	10 1/2	3 5/8	3 7/8		10 3/8	1 3/4	9 3/8	9 5/8						6.8
5																											

STANDARD SIGN
W4-4AL & W4-4AR

WISCONSIN DEPT OF TRANSPORTATION

APPROVED *Matthew R. Rauch*
for State Traffic Engineer

DATE 03/12/13 PLATE NO. W4-4A.2

PROJECT NO: _____ HWY: _____ COUNTY: _____ SHEET NO: _____ E

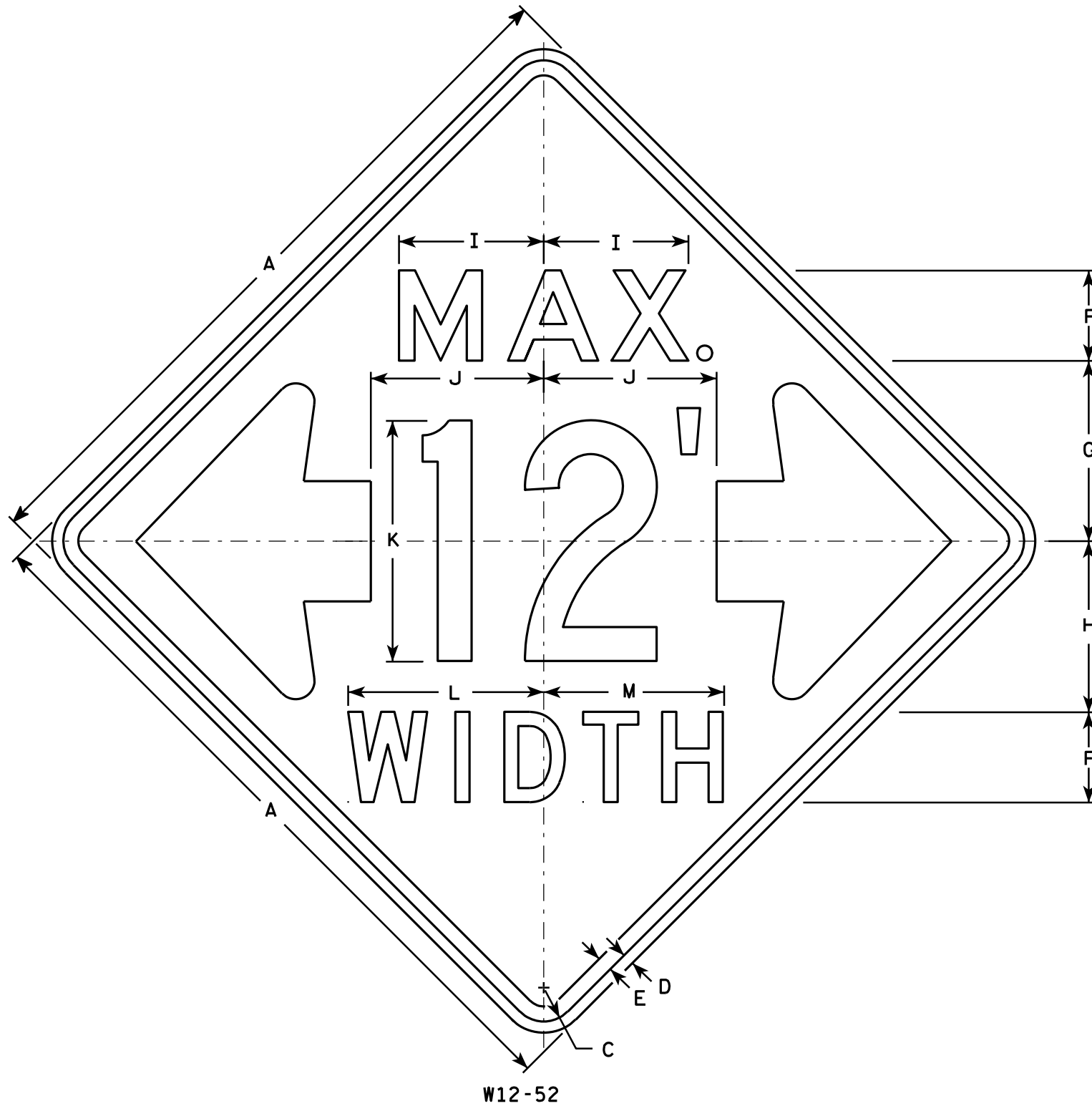

W12-52

NOTES

1. Sign is Type II - Type F Reflective - reference WIS DOT Standard Specification for HIGHWAY and STRUCTURE CONSTRUCTION latest edition.
2. Color:
Background - Orange
Message - Black
3. Message Series - See note 5
4. Corners may be square or rounded when base material is plywood but borders shall be rounded as shown. When base material is metal, the corners and borders shall be rounded.
5. The top line is series E, the numerals are series C, and the bottom line is series D.
6. Substitute appropriate numerals and adjust spacing as required.

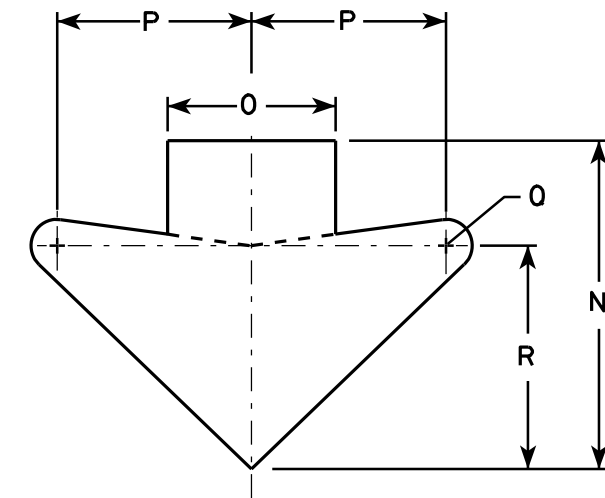

ARROW DETAIL

SIZE	A	B	C	D	E	F	G	H	I	J	K	L	M	N	O	P	Q	R	S	T	U	V	W	X	Y	Z	Area sq. ft.
1																											
2S	48		2 1/4	3/4	1	6	12	11 3/8	9 5/8	11 1/2	16	13	12	15 5/8	8	9 1/4	1 1/4	10 5/8								16.0	
2M	48		2 1/4	3/4	1	6	12	11 3/8	9 5/8	11 1/2	16	13	12	15 5/8	8	9 1/4	1 1/4	10 5/8								16.0	
3																											
4																											
5																											

STANDARD SIGN
W12-52

WISCONSIN DEPT OF TRANSPORTATION

APPROVED *Matthew R. Rauch*
for State Traffic Engineer

DATE 3/16/11 PLATE NO. W12-52.7

NOTES

1. Sign is Type II - Type F Reflective
2. Color:
Background - Orange
Message - Black
3. Message Series - C
4. Corners may be square or rounded when base material is plywood but borders shall be rounded as shown. When base material is metal, the corners and borders shall be rounded.

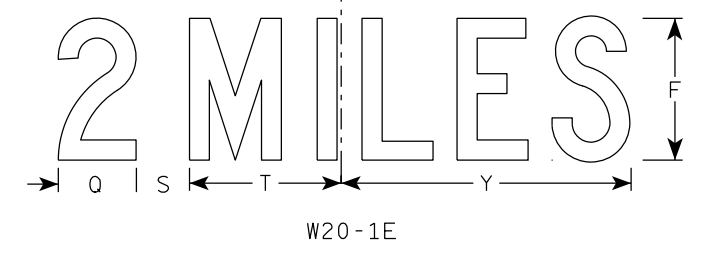
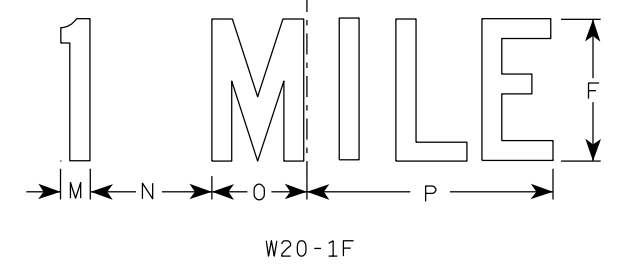
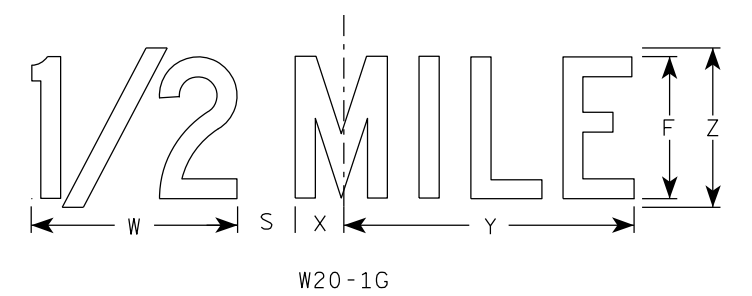
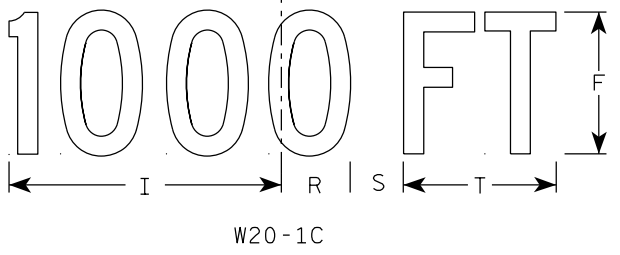
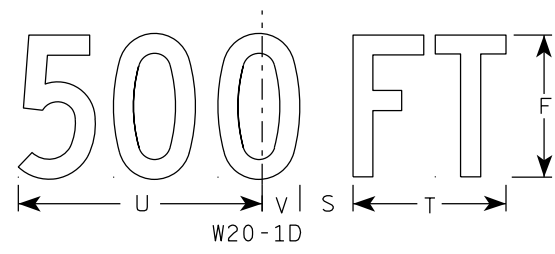
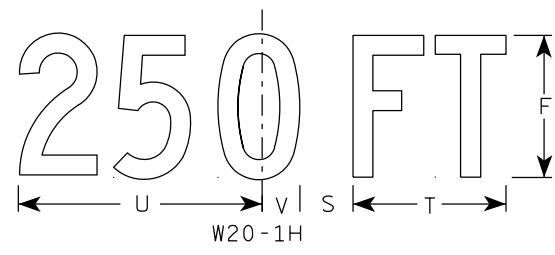
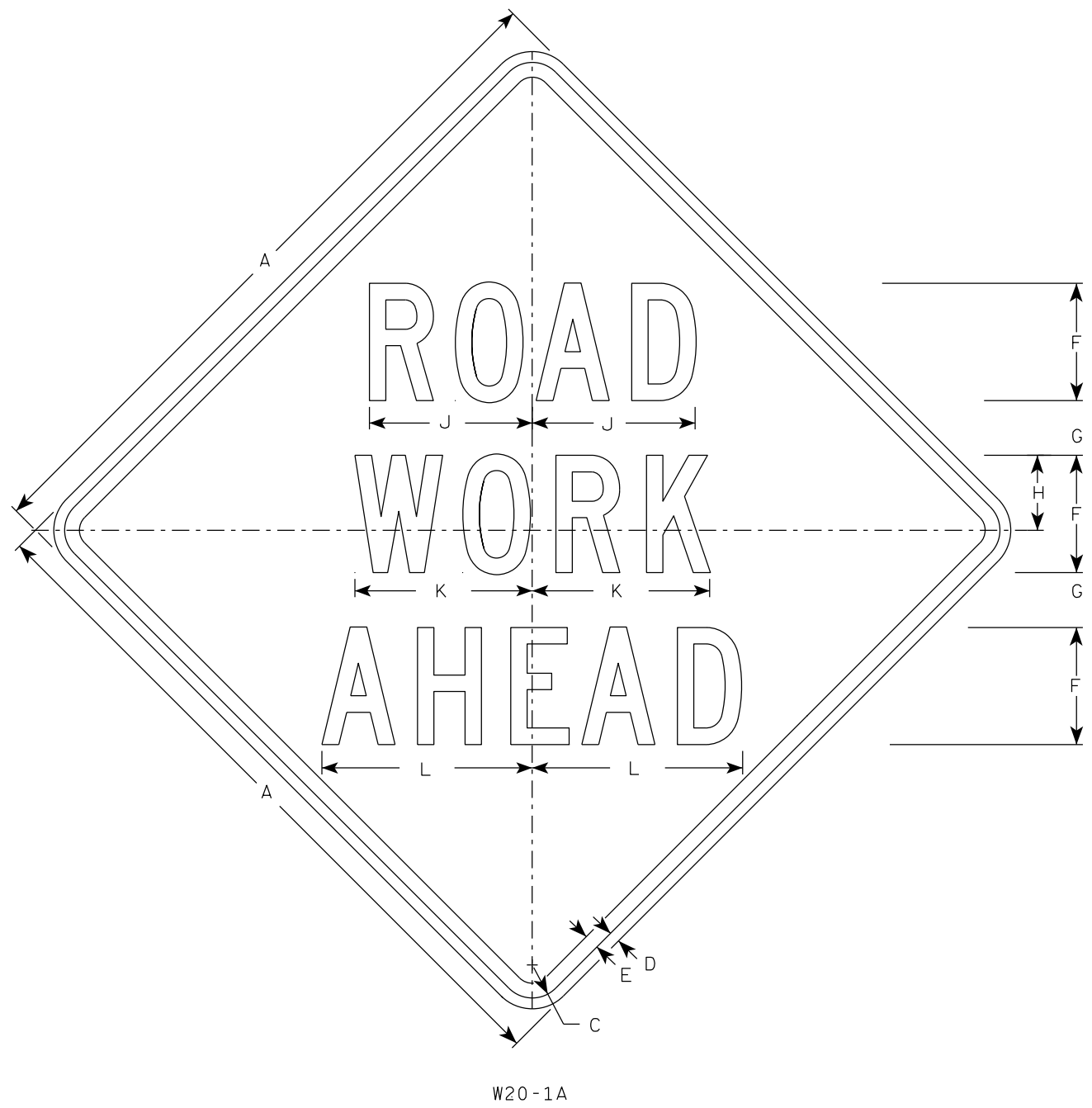

SIZE	A	B	C	D	E	F	G	H	I	J	K	L	M	N	O	P	Q	R	S	T	U	V	W	X	Y	Z	Area sq. ft.
1	36		1 5/8	5/8	3/4	5	2 5/8	3 1/4	10 1/8	7	7 5/8	8 7/8	1 1/8	4 1/2	3 1/2	9	3 1/4	2 1/2	2 1/4	5 5/8	9	1 3/8	8	1 3/4	10 3/4	6	9.0
2S	48		2 1/4	3/4	1	8	3 3/4	5 1/8	15 3/8	11 1/8	12 1/8	14 3/8	1 5/8	6 7/8	5 3/8	13 7/8	4 3/8	3 7/8	3	8 5/8	13 3/4	2 1/8	11 7/8	2 3/4	16 3/8	9	16.0
2M	48		2 1/4	3/4	1	8	3 3/4	5 1/8	15 3/8	11 1/8	12 1/8	14 3/8	1 5/8	6 7/8	5 3/8	13 7/8	4 3/8	3 7/8	3	8 5/8	13 3/4	2 1/8	11 7/8	2 3/4	16 3/8	9	16.0
3	48		2 1/4	3/4	1	8	3 3/4	5 1/8	15 3/8	11 1/8	12 1/8	14 3/8	1 5/8	6 7/8	5 3/8	13 7/8	4 3/8	3 7/8	3	8 5/8	13 3/4	2 1/8	11 7/8	2 3/4	16 3/8	9	16.0
4	48		2 1/4	3/4	1	8	3 3/4	5 1/8	15 3/8	11 1/8	12 1/8	14 3/8	1 5/8	6 7/8	5 3/8	13 7/8	4 3/8	3 7/8	3	8 5/8	13 3/4	2 1/8	11 7/8	2 3/4	16 3/8	9	16.0
5	48		2 1/4	3/4	1	8	3 3/4	5 1/8	15 3/8	11 1/8	12 1/8	14 3/8	1 5/8	6 7/8	5 3/8	13 7/8	4 3/8	3 7/8	3	8 5/8	13 3/4	2 1/8	11 7/8	2 3/4	16 3/8	9	16.0

STANDARD SIGN
W20-1A, B, C, D, E, F, G & H

WISCONSIN DEPT OF TRANSPORTATION

APPROVED *Matthew R. Rauch*
For State Traffic Engineer

DATE 3/25/2020 PLATE NO. W20-1.11

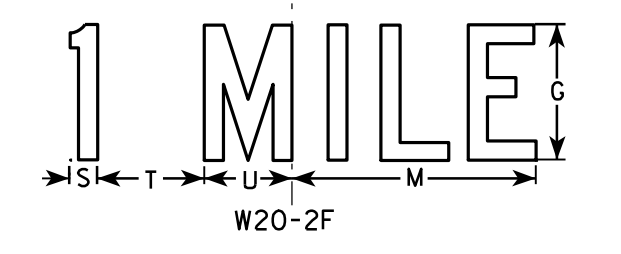
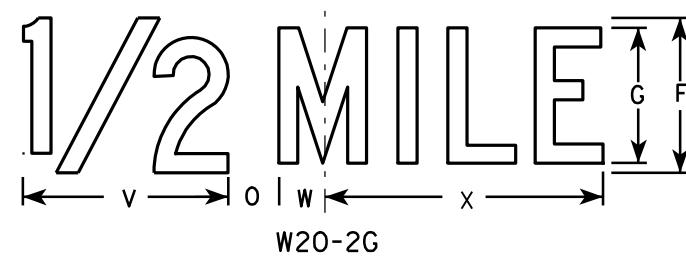
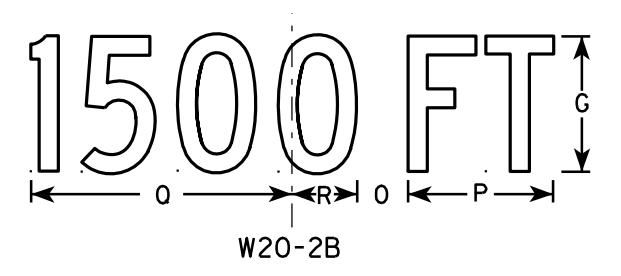
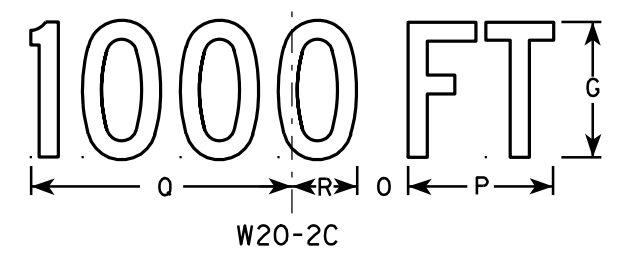
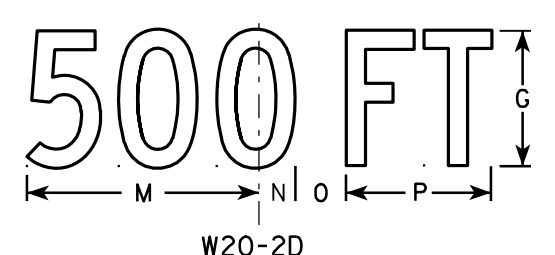
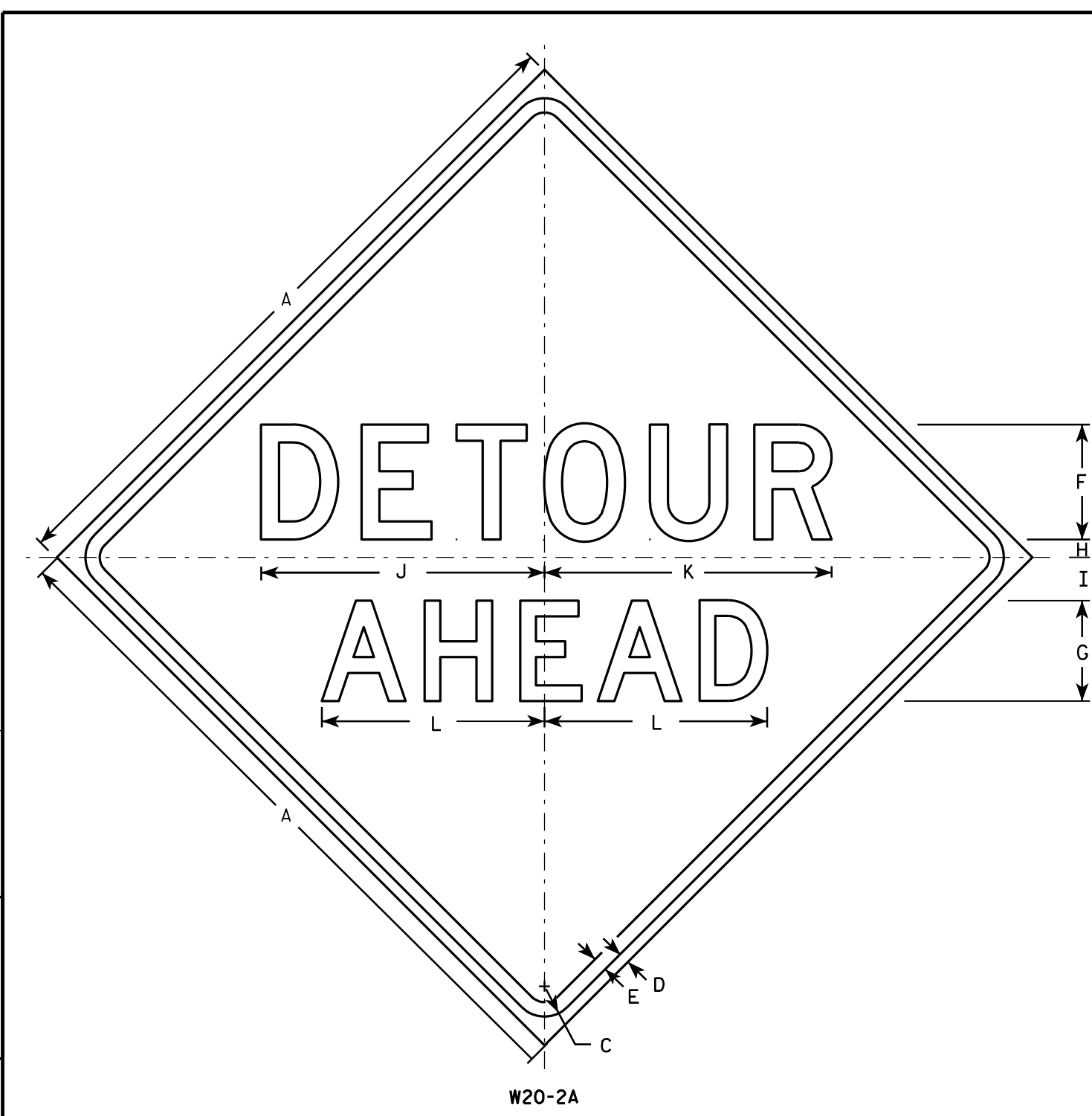

NOTES

1. Sign is Type II - Type F Reflective - reference WIS DOT Standard Specification for HIGHWAY and STRUCTURE CONSTRUCTION latest edition.
2. Color:
Background - Orange
Message - Black
3. Message Series - See note 5
4. Corners may be square or rounded when base material is plywood but borders shall be rounded as shown. When base material is metal, the corners and borders shall be rounded.
5. Line 1 is Series D.
Line 2 is Series D for AHEAD and Series C for all other distances.

7

7

SIZE	A	B	C	D	E	F	G	H	I	J	K	L	M	N	O	P	Q	R	S	T	U	V	W	X	Y	Z	Area sq. ft.
1	36		1 5/8	5/8	3/4	6	5	1	2 1/4	14 3/4	15	11 5/8	9	1 3/8	1 7/8	5 5/8	10 1/8	2 1/2	1 1/8	4 1/2	3 1/2	8	1 3/4	10 3/4			9.0
2S	48		2 1/4	3/4	1	8	7	1 1/4	3	19 3/4	20	15 1/2	12	1 7/8	2 5/8	7 1/2	13 1/2	3 3/8	1 1/2	6	4 5/8	10 5/8	2 3/8	14 3/8			16.0
2M	48		2 1/4	3/4	1	8	7	1 1/4	3	19 3/4	20	15 1/2	12	1 7/8	2 5/8	7 1/2	13 1/2	3 3/8	1 1/2	6	4 5/8	10 5/8	2 3/8	14 3/8			16.0
3	48		2 1/4	3/4	1	8	7	1 1/4	3	19 3/4	20	15 1/2	12	1 7/8	2 5/8	7 1/2	13 1/2	3 3/8	1 1/2	6	4 5/8	10 5/8	2 3/8	14 3/8			16.0
4	48		2 1/4	3/4	1	8	7	1 1/4	3	19 3/4	20	15 1/2	12	1 7/8	2 5/8	7 1/2	13 1/2	3 3/8	1 1/2	6	4 5/8	10 5/8	2 3/8	14 3/8			16.0
5	48		2 1/4	3/4	1	8	7	1 1/4	3	19 3/4	20	15 1/2	12	1 7/8	2 5/8	7 1/2	13 1/2	3 3/8	1 1/2	6	4 5/8	10 5/8	2 3/8	14 3/8			16.0

STANDARD SIGN
W20-2A, B, C, D, F & G

WISCONSIN DEPT OF TRANSPORTATION

APPROVED *Matthew R. Raub*
for State Traffic Engineer

DATE 3/18/11 PLATE NO. W20-2.6

PROJECT NO: _____ HWY: _____ COUNTY: _____ SHEET NO: _____ E

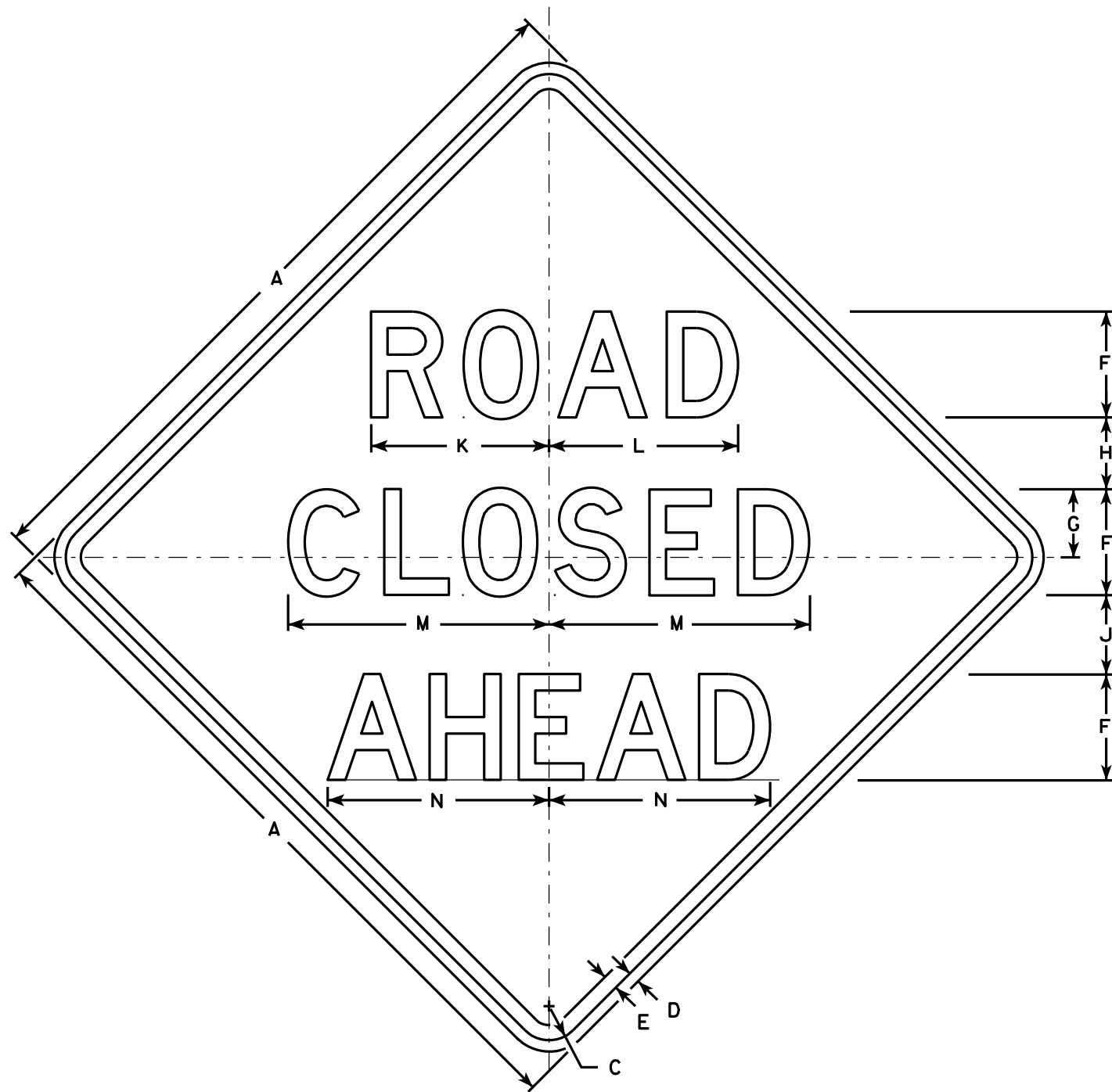

W20-3A

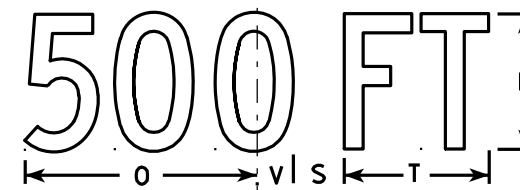

W20-3D

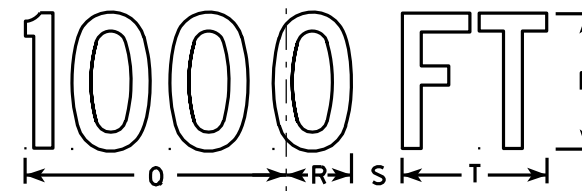

W20-3C

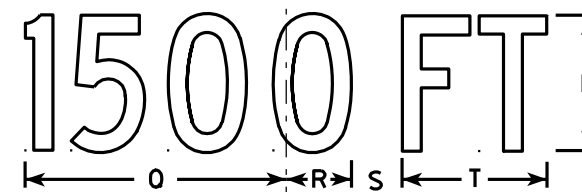

W20-3B

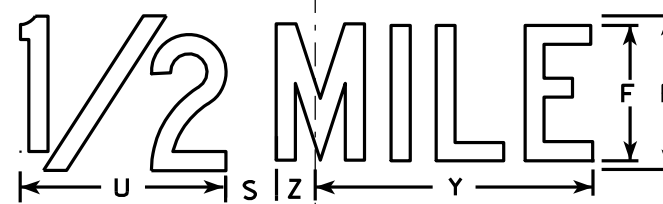

W20-3G

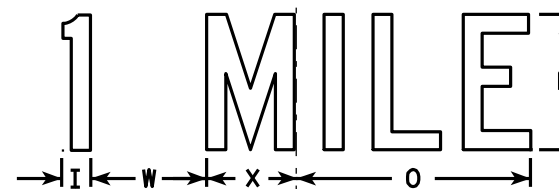

W20-3F

NOTES

1. Sign is Type II - Type F Reflective - reference WIS DOT Standard Specification for HIGHWAY and STRUCTURE CONSTRUCTION latest edition.
2. Color:
Background - Orange
Message - Black
3. Message Series - see note 5
4. Corners may be square or rounded when base material is plywood but borders shall be rounded as shown. When base material is metal, the corners and borders shall be rounded.
5. Lines 1 and 2 are Series D.
Line 3 is Series D for AHEAD and Series C for all other distances.

7

7

SIZE	A	B	C	D	E	F	G	H	I	J	K	L	M	N	O	P	Q	R	S	T	U	V	W	X	Y	Z	Area sq. ft.
1	36		1 5/8	5/8	3/4	5	3 3/8	3 1/2	1 1/8	4	8 3/8	8 7/8	12 1/2	11	9	6	10 1/8	2 1/2	1 7/8	5 5/8	8	1 3/8	4 1/2	3 1/2	10 3/4	1 3/4	9.0
2S	48		2 1/4	3/4	1	7	4 1/2	4 3/4	1 1/2	5 1/4	11 3/4	12 1/2	17 1/4	14 5/8	12	8	13 1/2	3 3/8	2 5/8	7 1/2	10 5/8	1 7/8	6	4 5/8	14 3/8	2 3/8	16.0
2M	48		2 1/4	3/4	1	7	4 1/2	4 3/4	1 1/2	5 1/4	11 3/4	12 1/2	17 1/4	14 5/8	12	8	13 1/2	3 3/8	2 5/8	7 1/2	10 5/8	1 7/8	6	4 5/8	14 3/8	2 3/8	16.0
3	48		2 1/4	3/4	1	7	4 1/2	4 3/4	1 1/2	5 1/4	11 3/4	12 1/2	17 1/4	14 5/8	12	8	13 1/2	3 3/8	2 5/8	7 1/2	10 5/8	1 7/8	6	4 5/8	14 3/8	2 3/8	16.0
4	48		2 1/4	3/4	1	7	4 1/2	4 3/4	1 1/2	5 1/4	11 3/4	12 1/2	17 1/4	14 5/8	12	8	13 1/2	3 3/8	2 5/8	7 1/2	10 5/8	1 7/8	6	4 5/8	14 3/8	2 3/8	16.0
5	48		2 1/4	3/4	1	7	4 1/2	4 3/4	1 1/2	5 1/4	11 3/4	12 1/2	17 1/4	14 5/8	12	8	13 1/2	3 3/8	2 5/8	7 1/2	10 5/8	1 7/8	6	4 5/8	14 3/8	2 3/8	16.0

STANDARD SIGN
W20-3A, B, C, D, F & G

WISCONSIN DEPT OF TRANSPORTATION

APPROVED *Matthew R. Rauch*
For State Traffic Engineer

DATE 3/18/11 PLATE NO. W20-3.7

PROJECT NO: _____ HWY: _____ COUNTY: _____ SHEET NO: _____ E

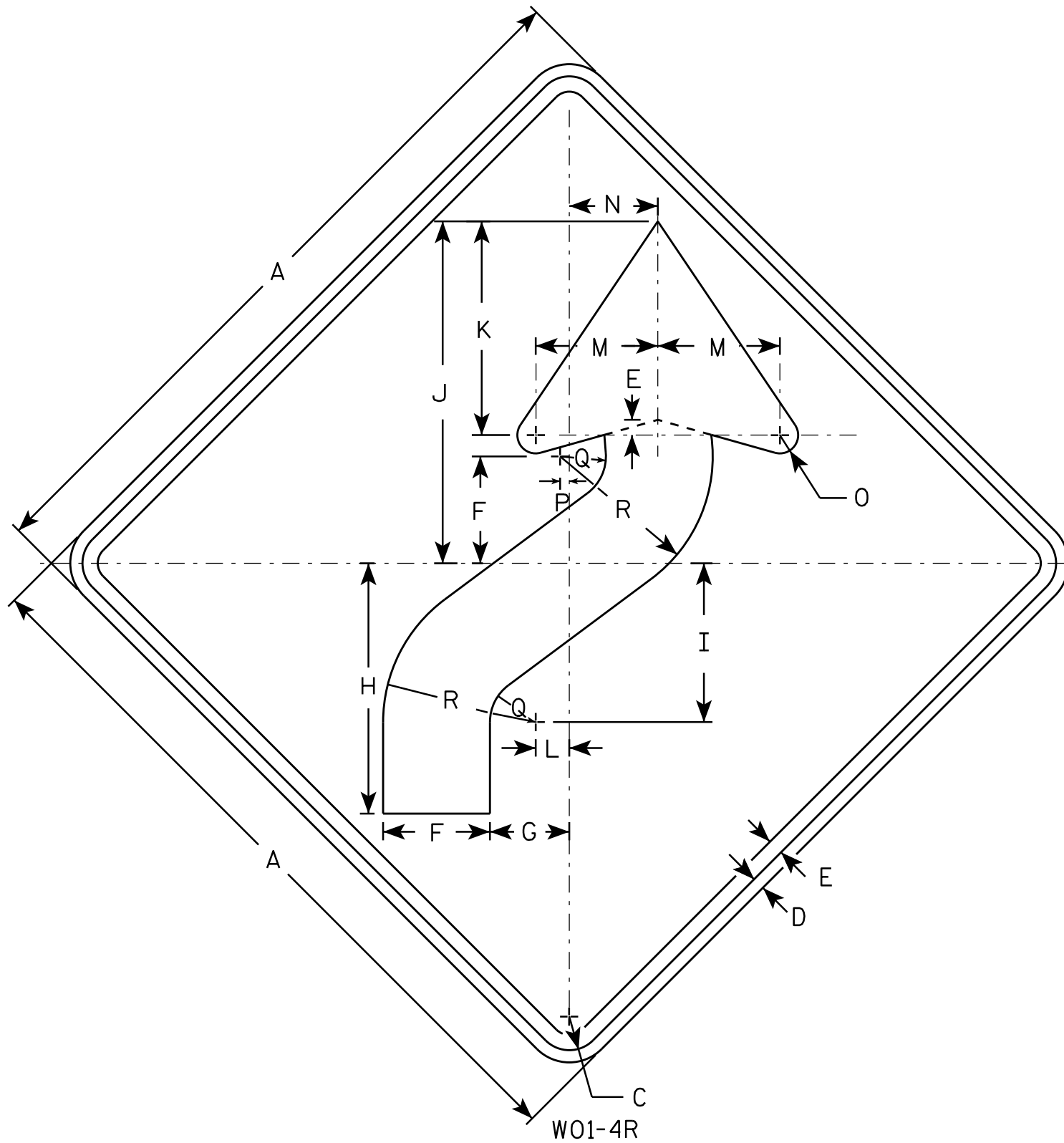

NOTES

1. Sign is Type II - Type F Reflective - reference WIS DOT Standard Specification for HIGHWAY and STRUCTURE CONSTRUCTION latest edition.
2. Color:
Background - Orange
Message - Black
3. Corners may be square or rounded when base material is plywood but borders shall be rounded as shown. When base material is metal, the corners and borders shall be rounded.
4. W01-4L is the same as W01-4R except the arrow is reversed along the vertical centerline.

7

7

SIZE	A	B	C	D	E	F	G	H	I	J	K	L	M	N	O	P	Q	R	S	T	U	V	W	X	Y	Z	Area sq. ft.
1	36		1 5/8	5/8	3/4	5 1/4	4	12 3/8	7 7/8	16 7/8	10 1/2	1 5/8	6	4 1/2	1	1/2	2 1/4	7 1/2									9.0
2S	48		2 1/4	3/4	1	7	5 1/4	16 1/2	10 1/2	22 1/2	14	2 1/4	8	6	1 1/4	5/8	3	10									16.0
2M	48		2 1/4	3/4	1	7	5 1/4	16 1/2	10 1/2	22 1/2	14	2 1/4	8	6	1 1/4	5/8	3	10									16.0
3	48		2 1/4	3/4	1	7	5 1/4	16 1/2	10 1/2	22 1/2	14	2 1/4	8	6	1 1/4	5/8	3	10									16.0
4	48		2 1/4	3/4	1	7	5 1/4	16 1/2	10 1/2	22 1/2	14	2 1/4	8	6	1 1/4	5/8	3	10									16.0
5	48		2 1/4	3/4	1	7	5 1/4	16 1/2	10 1/2	22 1/2	14	2 1/4	8	6	1 1/4	5/8	3	10									16.0

PROJECT NO: _____ HWY: _____ COUNTY: _____ SHEET NO: **E**

STANDARD SIGN
W01-4

WISCONSIN DEPT OF TRANSPORTATION

APPROVED *Matthew R. Rauch*
for State Traffic Engineer

DATE 11/18/13 PLATE NO. W01-4.1

NOTES

1. Sign is Type II - Type F Reflective - reference WIS DOT Standard Specification for HIGHWAY and STRUCTURE CONSTRUCTION latest edition.
2. Color:
Background - Orange
Message - Black
3. Corners may be square or rounded when base material is plywood but borders shall be rounded as shown. When base material is metal, the corners and borders shall be rounded.

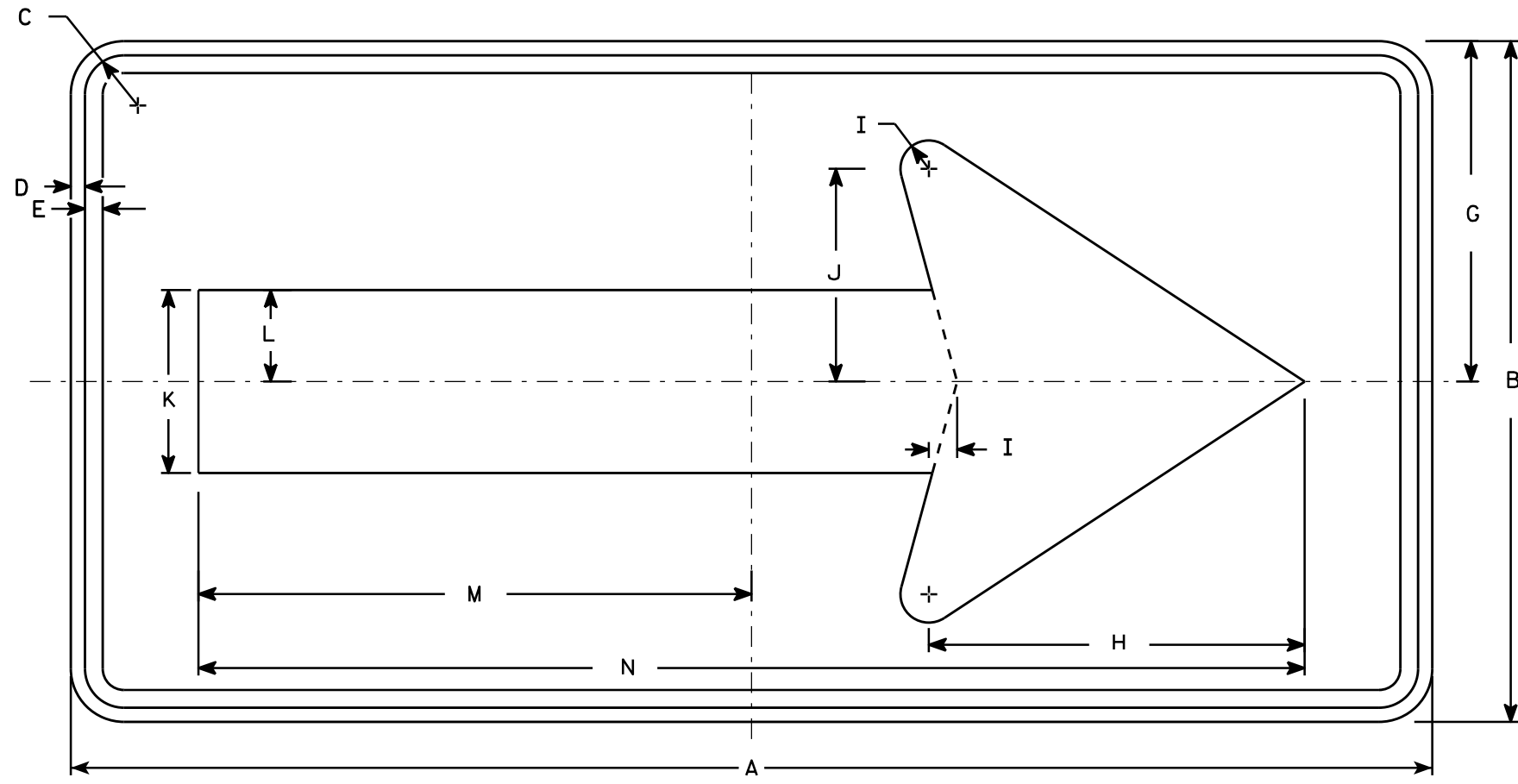

W01-6

7

7

SIZE	A	B	C	D	E	F	G	H	I	J	K	L	M	N	O	P	Q	R	S	T	U	V	W	X	Y	Z	Area sq. ft.
1																											
2S	48	24	1 3/8	1/2	5/8		12	13 1/4	1	7 1/2	6 1/2	3 1/4	19 1/2	39													8.0
2M	48	24	1 3/8	1/2	5/8		12	13 1/4	1	7 1/2	6 1/2	3 1/4	19 1/2	39													8.0
3	60	30	1 3/8	1/2	5/8		15	16 1/4	1 1/4	9 1/4	8	4	24 3/8	48 3/4													12.5
4	60	30	1 3/8	1/2	5/8		15	16 1/4	1 1/4	9 1/4	8	4	24 3/8	48 3/4													12.5
5	60	30	1 3/8	1/2	5/8		15	16 1/4	1 1/4	9 1/4	8	4	24 3/8	48 3/4													12.5

STANDARD SIGN
W01-6

WISCONSIN DEPT OF TRANSPORTATION

APPROVED *Matthew R. Rauch*
for State Traffic Engineer

DATE 11/18/13 PLATE NO. W01-6.1

PROJECT NO: _____ HWY: _____ COUNTY: _____ SHEET NO: **E**

NOTES

1. Fixed Message Signs Type II - Type F Reflective
2. Color:
Background - Orange
Message - Black
3. Message Series - C

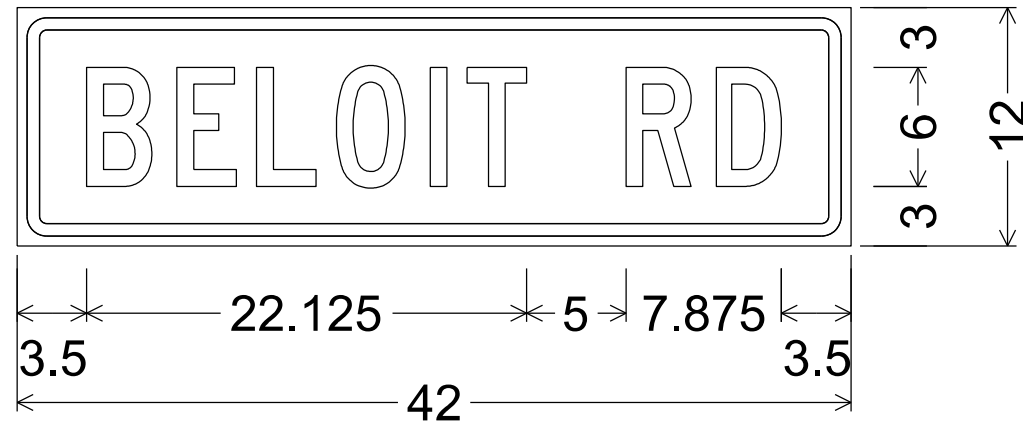

1.500" Radius, 0.625" Border, 0.500" Indent

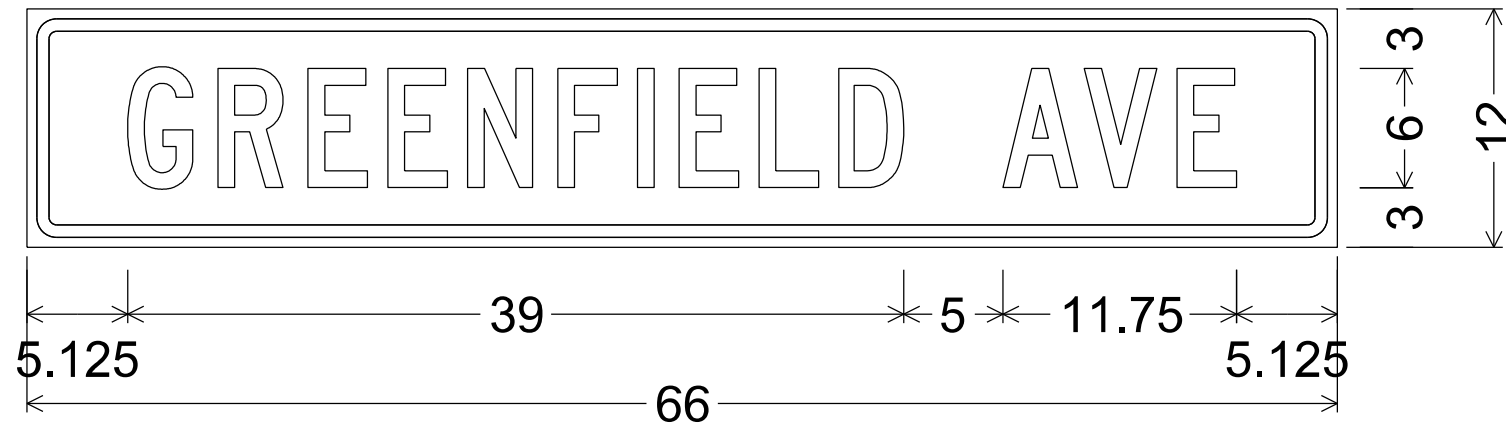

1.500" Radius, 0.625" Border, 0.500" Indent

7

7

DIVISION 1 - ALI-GREENFIELD

STATION	REAL STATION	DISTANCE	AREA (SF)			INCREMENTAL VOL (CY) (UNADJUSTED)			CUMULATIVE VOL (CY)		
			CUT	SALVAGED/UNUSABLE PAVEMENT MATERIAL	FILL	CUT NOTE 1	SALVAGED/UNUSABLE PAVEMENT MATERIAL NOTE 2	FILL NOTE 3	CUT 1.00 NOTE 1	EXPANDED FILL 1.15	MASS ORDINATE
23+50	2350.00	0.00	155.60	39.07	0.00	0	0	0	0	0	0
23+75	2375.00	25.00	160.52	37.87	0.00	146	36	0	146	0	110
24+00	2400.00	25.00	161.11	37.80	0.00	149	35	0	295	0	224
24+25	2425.00	25.00	159.35	37.74	0.00	148	35	0	443	0	337
24+50	2450.00	25.00	170.44	41.59	0.00	153	37	0	596	0	453
24+75	2475.00	25.00	190.33	44.31	0.00	167	40	0	763	0	580
25+00	2500.00	25.00	166.95	37.40	0.00	165	38	0	928	0	707
25+25	2525.00	25.00	152.62	37.94	0.00	148	35	0	1,076	0	820
25+50	2550.00	25.00	162.51	42.24	0.00	146	37	0	1,222	0	929
25+75	2575.00	25.00	133.93	38.24	0.00	137	37	0	1,359	0	1,029
26+00	2600.00	25.00	125.81	40.24	0.00	120	36	0	1,479	0	1,113
26+25	2625.00	25.00	188.12	50.94	0.00	145	42	0	1,624	0	1,216
26+35	2634.70	9.70	200.04	51.96	0.00	70	18	0	1,694	0	1,268
26+50	2650.00	15.30	200.91	48.32	0.00	114	28	0	1,808	0	1,354
26+75	2675.00	25.00	161.53	37.73	0.00	168	40	0	1,976	0	1,482
27+00	2700.00	25.00	147.73	37.39	0.00	143	35	0	2,119	0	1,590
27+25	2725.00	25.00	137.32	37.84	0.00	132	35	0	2,251	0	1,687
27+50	2750.00	25.00	132.42	38.24	0.14	125	35	0	2,376	0	1,777
27+75	2775.00	25.00	138.99	38.09	0.00	126	35	0	2,502	0	1,868
28+00	2800.00	25.00	151.89	37.91	0.00	135	35	0	2,637	0	1,968
28+25	2825.00	25.00	160.01	37.96	0.00	144	35	0	2,781	0	2,077
28+50	2850.00	25.00	162.48	37.91	0.00	149	35	0	2,930	0	2,191
28+75	2875.00	25.00	159.44	38.41	0.00	149	35	0	3,079	0	2,305
29+00	2900.00	25.00	143.15	38.18	0.08	140	35	0	3,219	0	2,410
29+25	2925.00	25.00	205.14	40.47	0.00	161	36	0	3,380	0	2,535
29+50	2950.00	25.00	221.46	66.71	0.00	198	50	0	3,578	0	2,683
29+75	2975.00	25.00	140.17	38.34	0.00	167	49	0	3,745	0	2,801
30+00	3000.00	25.00	160.16	37.78	0.00	139	35	0	3,884	0	2,905
30+25	3025.00	25.00	166.62	38.29	0.00	151	35	0	4,035	0	3,021
30+50	3050.00	25.00	176.52	37.98	0.00	159	35	0	4,194	0	3,145
30+75	3075.00	25.00	173.79	37.05	0.00	162	35	0	4,356	0	3,272
30+85	3085.20	10.20	205.15	47.37	0.00	72	16	0	4,428	0	3,328
31+00	3100.00	14.80	169.60	36.99	0.00	103	23	0	4,531	0	3,408
31+25	3125.00	25.00	153.60	38.27	0.00	150	35	0	4,681	0	3,523
31+50	3150.00	25.00	144.18	38.99	0.00	138	36	0	4,819	0	3,625
31+75	3175.00	25.00	140.28	39.56	0.00	132	36	0	4,951	0	3,721
32+00	3200.00	25.00	125.23	38.44	0.00	123	36	0	5,074	0	3,808
32+25	3225.00	25.00	216.17	53.66	0.00	158	43	0	5,232	0	3,923
32+50	3250.00	25.00	219.22	60.40	0.00	202	53	0	5,434	0	4,072
32+75	3275.00	25.00	128.99	38.28	0.00	161	46	0	5,595	0	4,187
33+00	3300.00	25.00	155.07	38.42	0.00	132	36	0	5,727	0	4,283
33+25	3325.00	25.00	154.69	38.89	0.00	143	36	0	5,870	0	4,390
33+50	3350.00	25.00	159.57	38.30	0.00	145	36	0	6,015	0	4,499
33+75	3375.00	25.00	166.18	37.98	0.00	151	35	0	6,166	0	4,615
33+84	3383.89	8.89	192.24	45.03	0.00	59	14	0	6,225	0	4,660
34+00	3400.00	16.11	159.72	38.43	0.00	105	25	0	6,330	0	4,740
34+25	3425.00	25.00	160.43	38.31	0.00	148	36	0	6,478	0	4,852
34+50	3450.00	25.00	163.25	38.21	0.00	150	35	0	6,628	0	4,967
34+75	3475.00	25.00	166.83	41.83	0.00	153	37	0	6,781	0	5,083
35+00	3500.00	25.00	147.04	37.98	0.00	145	37	0	6,926	0	5,191

DIVISION 1 - ALI-GREENFIELD

STATION	REAL STATION	DISTANCE	AREA (SF)			INCREMENTAL VOL (CY) (UNADJUSTED)			CUMULATIVE VOL (CY)		
			CUT	SALVAGED/UNUSABLE PAVEMENT MATERIAL	FILL	CUT	SALVAGED/UNUSABLE PAVEMENT MATERIAL	FILL	CUT	EXPANDED FILL	MASS ORDINATE
35+25	3525.00	25.00	224.97	59.77	0.00	172	45	0	7,098	0	5,318
35+50	3550.00	25.00	235.78	59.88	0.00	213	55	0	7,311	0	5,476
35+75	3575.00	25.00	158.44	38.47	0.00	183	46	0	7,494	0	5,613
36+00	3600.00	25.00	191.82	39.67	0.00	162	36	0	7,656	0	5,739
36+25	3625.00	25.00	196.13	39.71	0.00	180	37	0	7,836	0	5,882
36+50	3650.00	25.00	192.22	39.62	0.00	180	37	0	8,016	0	6,025
36+75	3675.00	25.00	174.56	39.86	0.00	170	37	0	8,186	0	6,158
37+00	3700.00	25.00	169.82	39.66	0.00	159	37	0	8,345	0	6,280
37+25	3725.00	25.00	168.75	39.72	0.00	157	37	0	8,502	0	6,400
37+50	3750.00	25.00	156.67	41.68	0.00	151	38	0	8,653	0	6,513
37+75	3775.00	25.00	149.58	44.10	0.00	142	40	0	8,795	0	6,615
38+00	3800.00	25.00	198.05	50.62	0.00	161	44	0	8,956	0	6,732
38+25	3825.00	25.00	193.44	47.70	0.00	181	46	0	9,137	0	6,867
38+50	3850.00	25.00	174.00	39.83	0.00	170	41	0	9,307	0	6,996
38+75	3875.00	25.00	175.03	39.51	0.00	162	37	0	9,469	0	7,121
39+00	3900.00	25.00	162.19	43.37	0.00	156	38	0	9,625	0	7,239
39+25	3925.00	25.00	156.52	38.90	1.79	148	38	1	9,773	1	7,348
39+50	3950.00	25.00	156.86	38.42	0.00	145	36	1	9,918	2	7,456
39+75	3975.00	25.00	164.78	38.38	0.00	149	36	0	10,067	2	7,569
39+95	3995.16	20.16	191.71	44.10	0.00	133	31	0	10,200	2	7,671
40+00	4000.00	4.84	178.99	38.15	0.08	33	7	0	10,233	2	7,697
40+25	4025.00	25.00	176.00	38.00	0.00	164	35	0	10,397	2	7,826
40+50	4050.00	25.00	201.78	46.97	0.00	175	39	0	10,572	2	7,962
40+75	4075.00	25.00	202.17	48.07	0.00	187	44	0	10,759	2	8,105
41+00	4100.00	25.00	169.44	42.61	0.00	172	42	0	10,931	2	8,235
41+25	4125.00	25.00	150.27	37.38	0.00	148	37	0	11,079	2	8,346
41+50	4150.00	25.00	162.41	38.29	0.00	145	35	0	11,224	2	8,456
41+75	4175.00	25.00	166.83	39.96	0.00	152	36	0	11,376	2	8,572
41+80	4179.68	4.68	167.14	39.96	0.00	29	7	0	11,405	2	8,594
42+00	4200.00	20.32	159.74	38.52	0.00	123	30	0	11,528	2	8,687
42+25	4225.00	25.00	159.16	38.01	0.00	148	35	0	11,676	2	8,800
42+34	4234.13	9.13	162.91	39.88	0.00	54	13	0	11,730	2	8,841
42+50	4250.00	15.87	153.22	37.91	0.00	93	23	0	11,823	2	8,911
42+75	4275.00	25.00	146.35	38.32	0.00	139	35	0	11,962	2	9,015
43+00	4300.00	25.00	137.78	37.73	0.00	132	35	0	12,094	2	9,112
43+25	4325.00	25.00	124.43	34.73	0.00	121	34	0	12,215	2	9,199
43+50	4350.00	25.00	135.03	34.78	0.00	120	32	0	12,335	2	9,287
43+75	4375.00	25.00	188.63	38.47	0.00	150	34	0	12,485	2	9,403
44+00	4400.00	25.00	192.63	49.11	0.00	177	41	0	12,662	2	9,539
44+25	4425.00	25.00	147.95	38.75	0.00	158	41	0	12,820	2	9,656
44+50	4450.00	25.00	136.73	40.59	0.01	132	37	0	12,952	2	9,751
44+75	4475.00	25.00	133.34	39.66	0.00	125	37	0	13,077	2	9,839
45+00	4500.00	0.00	134.70	40.02	0.00	0	0	0	13,077	2	9,839
45+25	4525.00	25.00	135.28	39.99	0.00	125	37	0	13,202	2	9,927
45+50	4550.00	25.00	163.66	53.67	0.00	138	43	0	13,340	2	10,022
45+75	4575.00	25.00	169.06	49.11	0.00	154	48	0	13,494	2	10,128
45+86	4585.57	10.57	169.87	49.88	0.00	66	19	0	13,560	2	10,175
46+00	4600.00	14.43	170.45	49.96	0.00	91	27	0	13,651	2	10,239
46+25	4625.00	25.00	173.55	49.83	0.00	159	46	0	13,810	2	10,352
46+50	4650.00	25.00	174.66	46.58	0.00	161	45	0	13,971	2	10,468

DIVISION 1 - ALI-GREENFIELD

STATION	REAL STATION	DISTANCE	AREA (SF)			INCREMENTAL VOL (CY) (UNADJUSTED)			CUMULATIVE VOL (CY)		
			CUT	SALVAGED/UNUSABLE PAVEMENT MATERIAL	FILL	CUT	SALVAGED/UNUSABLE PAVEMENT MATERIAL	FILL	CUT	EXPANDED FILL	MASS ORDNATE
46+61	4661.15	11.15	184.51	50.58	0.00	74	20	0	14,045	2	10,522
46+75	4675.00	13.85	174.20	48.58	0.00	92	25	0	14,137	2	10,589
47+00	4700.00	25.00	167.90	46.71	0.00	158	44	0	14,295	2	10,703
47+25	4725.00	25.00	161.49	44.35	0.00	152	42	0	14,447	2	10,813
47+50	4750.00	25.00	159.22	43.41	0.00	148	41	0	14,595	2	10,920
47+75	4775.00	25.00	148.21	42.16	0.02	142	40	0	14,737	2	11,022
48+00	4800.00	25.00	146.92	45.30	0.00	137	40	0	14,874	2	11,119
48+25	4825.00	25.00	146.38	44.17	0.00	136	41	0	15,010	2	11,214
48+50	4850.00	25.00	150.41	43.64	0.00	137	41	0	15,147	2	11,310
48+75	4875.00	25.00	149.89	42.96	0.00	139	40	0	15,286	2	11,409
49+00	4900.00	25.00	137.62	38.97	0.00	133	38	0	15,419	2	11,504
49+25	4925.00	25.00	136.13	39.23	0.00	127	36	0	15,546	2	11,595
49+50	4949.91	24.91	153.37	39.59	0.00	134	36	0	15,680	2	11,693
49+75	4975.00	25.09	0.00	0.00	0.00	71	18	0	15,751	2	11,746

DIVISION 1 - ALI-BELOIT

STATION	REAL STATION	DISTANCE	AREA (SF)			INCREMENTAL VOL (CY) (UNADJUSTED)			CUMULATIVE VOL (CY)			
			CUT	SALVAGED/UNUSABLE PAVEMENT MATERIAL	FILL	CUT	SALVAGED/UNUSABLE PAVEMENT MATERIAL	FILL	CUT	EXPANDED FILL		MASS ORDINATE
										1.00	1.15	
			NOTE 1	NOTE 2	NOTE 3	NOTE 1	NOTE 1	NOTE 8				
504+00	50400.00	0.00	132.49	32.00	0.00	0	0	0	0	0	0	
504+25	50425.00	25.00	141.10	32.74	0.00	127	30	0	127	0	97	
504+50	50450.00	25.00	151.44	37.17	0.00	135	32	0	262	0	200	
504+75	50475.00	25.00	154.44	41.13	0.00	142	36	0	404	0	306	
505+00	50500.00	25.00	197.34	52.32	0.00	163	43	0	567	0	426	
505+25	50525.00	25.00	156.68	39.06	0.00	164	42	0	731	0	548	
506+50	50650.00	0.00	127.68	31.54	0.00	0	0	0	731	0	548	
506+75	50675.00	25.00	185.22	46.26	0.00	145	36	0	876	0	657	
507+00	50700.00	25.00	153.03	38.73	0.00	157	39	0	1,033	0	775	
507+14.76	50714.76	14.76	149.54	40.40	0.02	83	22	0	1,116	0	836	
507+25	50725.00	10.24	134.10	32.41	0.00	54	14	0	1,170	0	876	

NOTES:	
1 - CUT	CUT INCLUDES SALVAGED/UNUSABLE PAVEMENT MATERIAL
2 - SALVAGED/UNUSABLE PAVEMENT MATERIAL	THIS DOES NOT SHOW UP IN CROSS SECTIONS
3 - FILL	DOES NOT INCLUDE UNUSABLE PAVEMENT EXC VOLUME

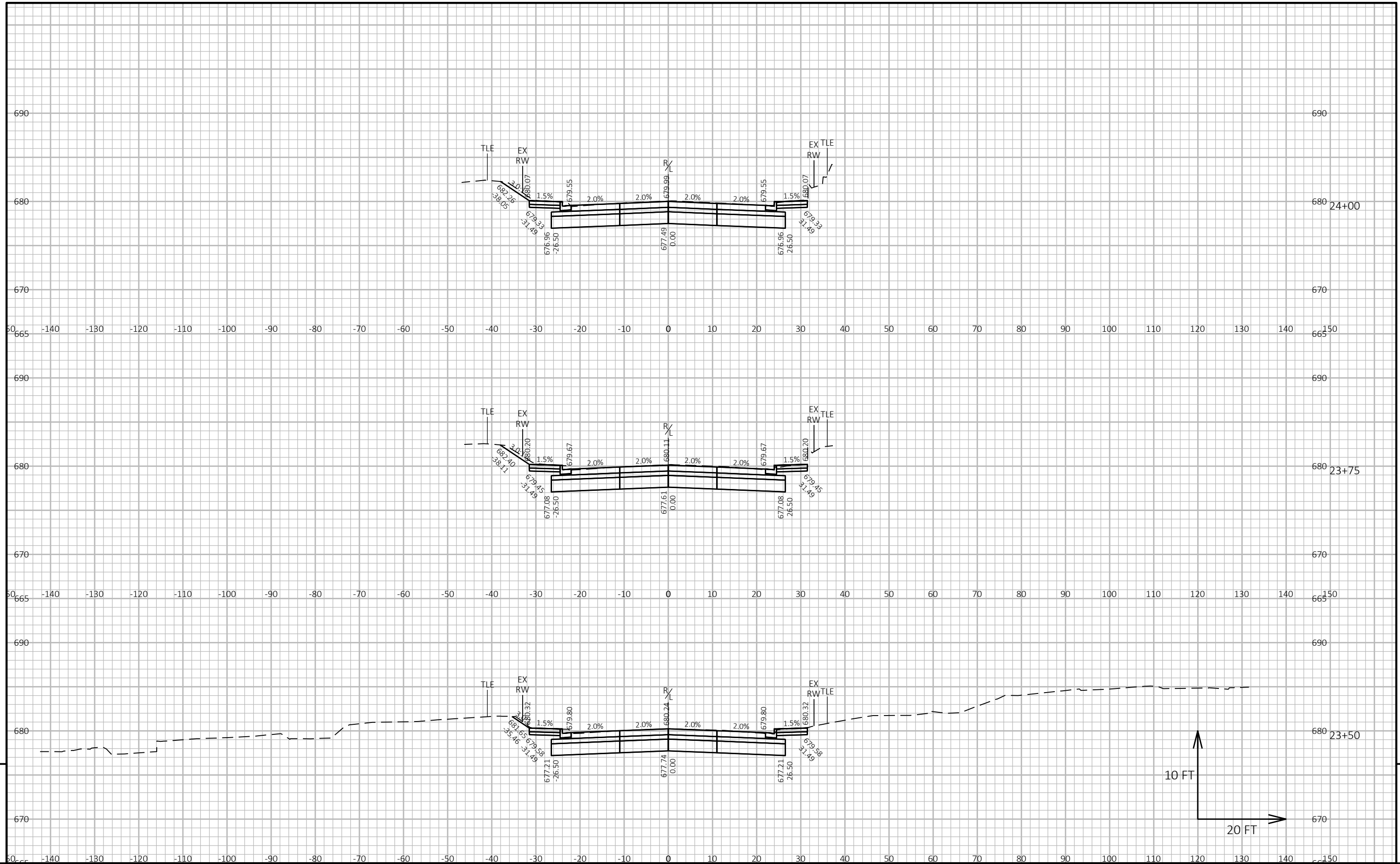

PROJECT NO: 2230-07-73

HWY: W. GREENFIELD AVENUE

COUNTY: MILWAUKEE

CROSS SECTIONS - W GREENFIELD AVENUE

SHEET

E

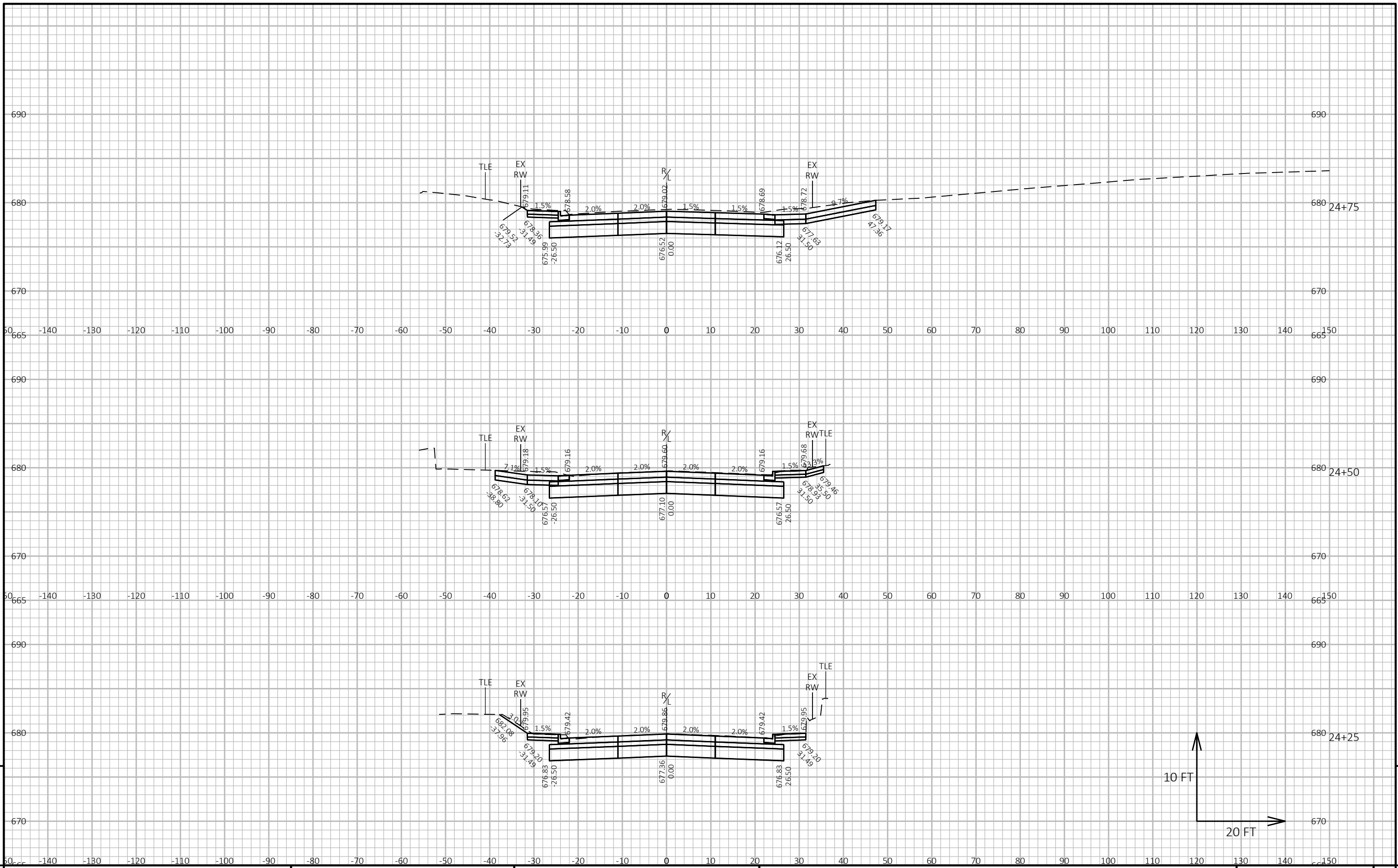

PROJECT NO: 2230-07-73

HWY: W. GREENFIELD AVENUE

COUNTY: MILWAUKEE

CROSS SECTIONS - W GREENFIELD AVENUE

SHEET

E

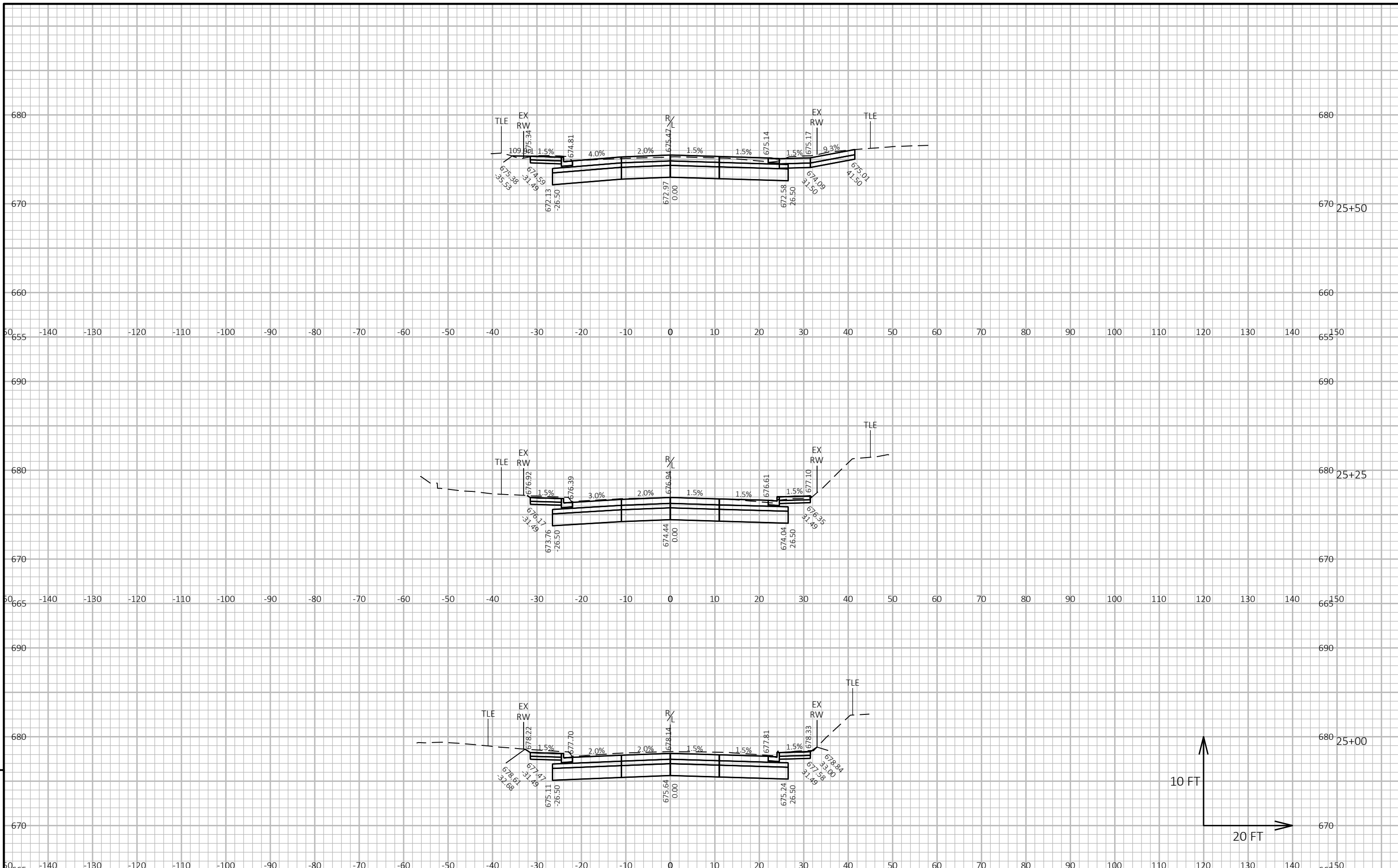

9

9

PROJECT NO: 2230-07-73 HWY: W. GREENFIELD AVENUE COUNTY: MILWAUKEE CROSS SECTIONS - W GREENFIELD AVENUE SHEET E

FILE NAME : X:\ML\2021\20210099\DESIGN\TRANSPORTATION\SHEETSPLAN\090201_XS.DWG PLOT DATE : 7/19/2023 2:15 PM PLOT BY : BIEBERITZ, BEN PLOT NAME : PLOT SCALE : 1 IN:20 FT HORZ. / 1 IN:10 FT VERT. WISDOT/CADD SHEET 49

LAYOUT NAME - 090203_xs

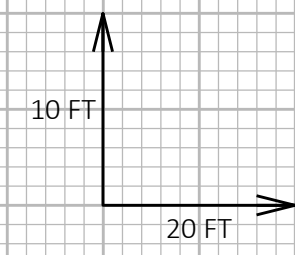
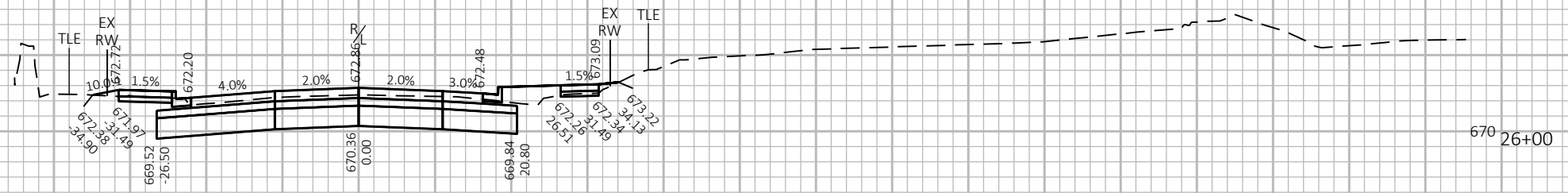
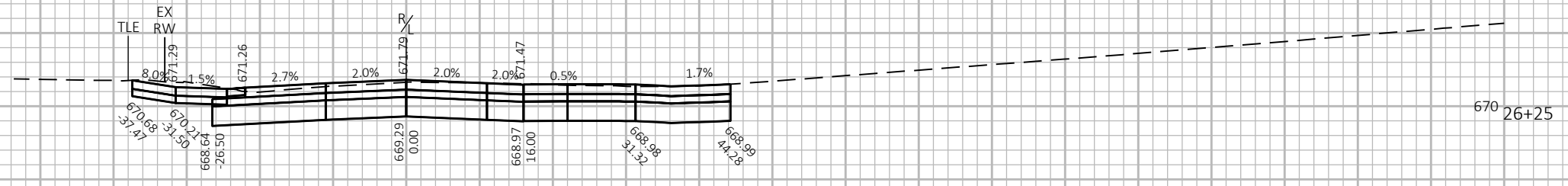

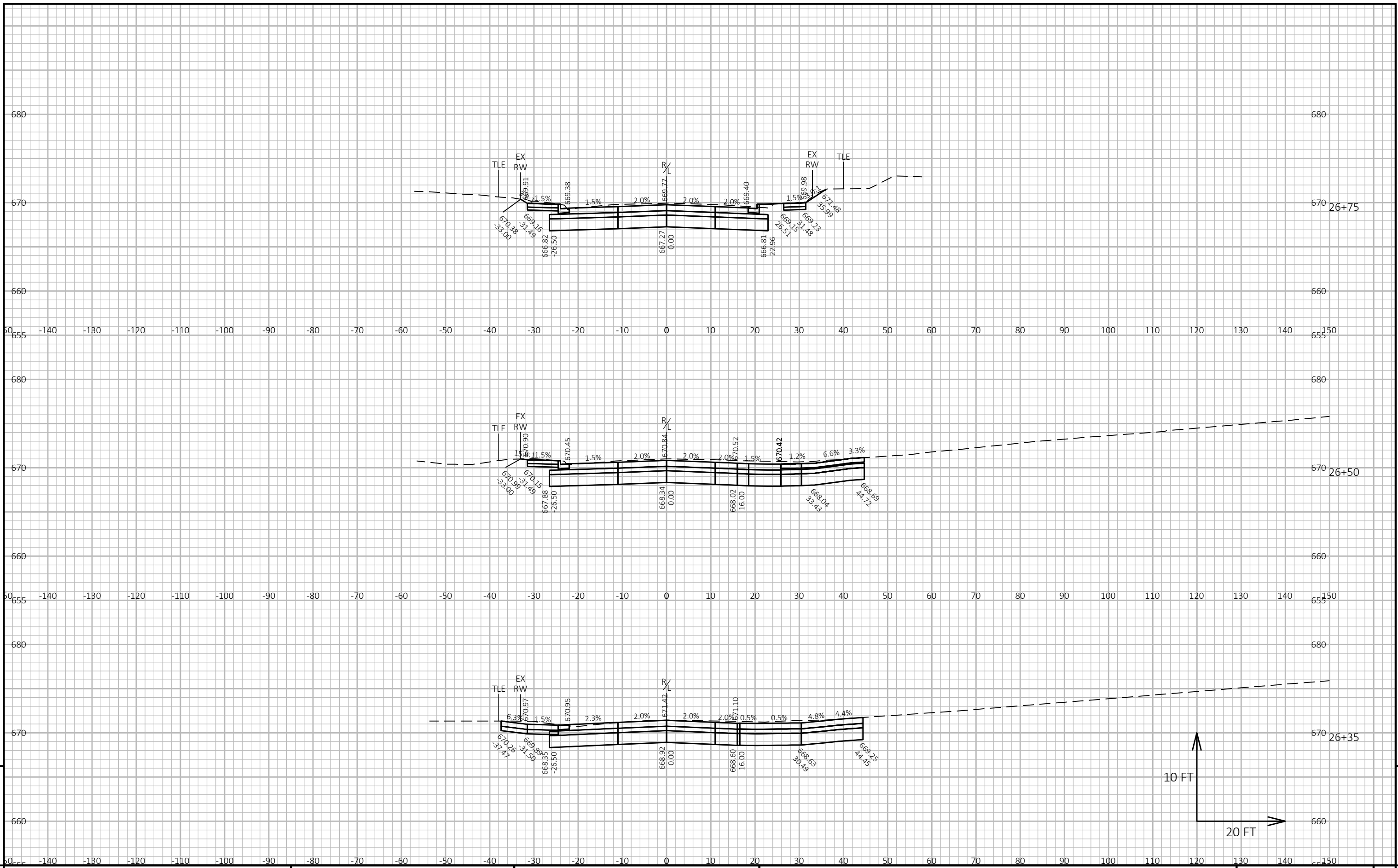

9

9

PROJECT NO: 2230-07-73 HWY: W. GREENFIELD AVENUE COUNTY: MILWAUKEE CROSS SECTIONS - W GREENFIELD AVENUE SHEET E

FILE NAME : X:\ML\2021\20210099\DESIGN\TRANSPORTATION\SHEETSPLAN\090201_XS.DWG PLOT DATE : 7/19/2023 2:15 PM PLOT BY : BIEBERITZ, BEN PLOT NAME : PLOT SCALE : 1 IN:20 FT HORZ. / 1 IN:10 FT VERT. WISDOT/CADD SHEET 49

LAYOUT NAME - 090205_xs

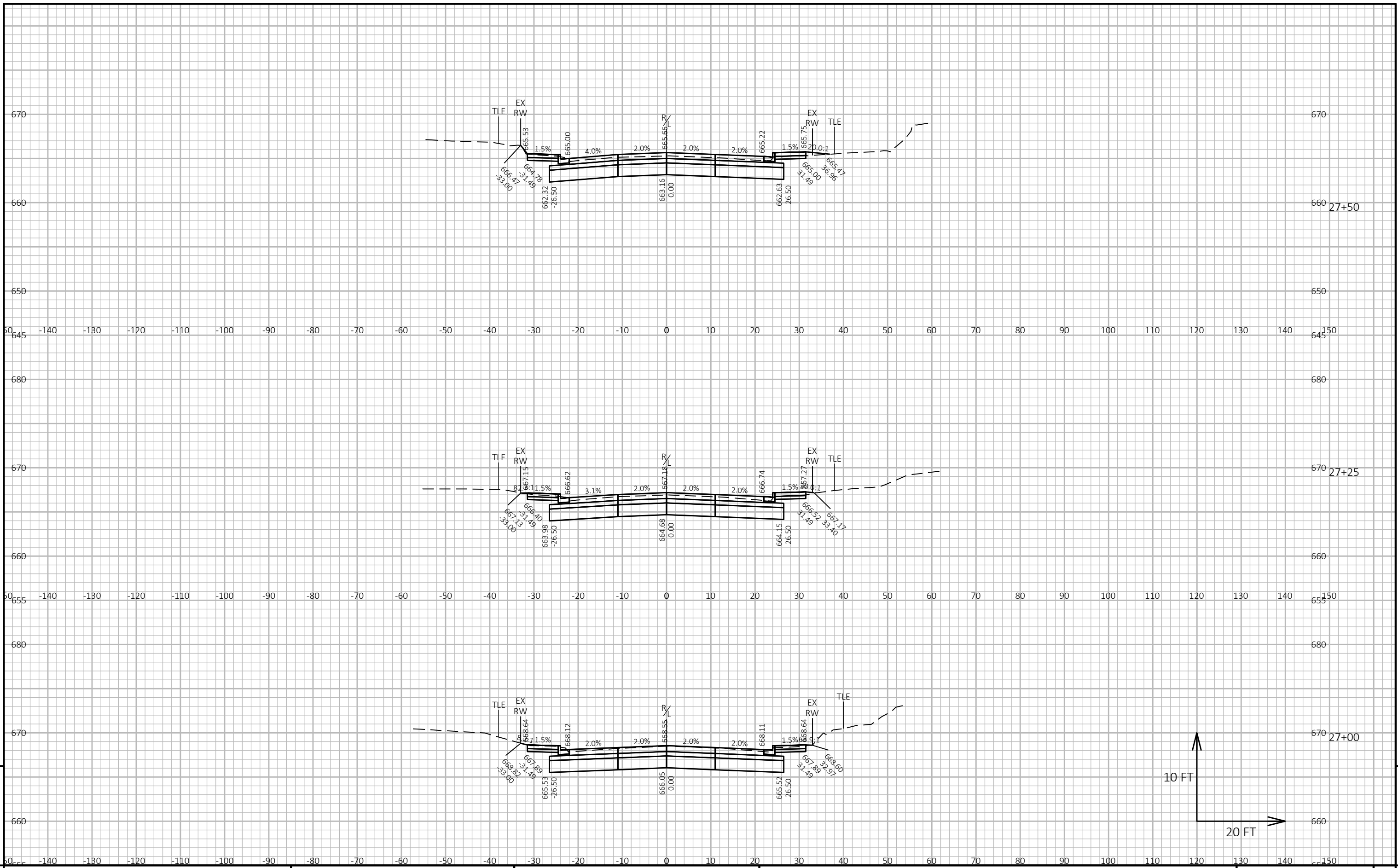

9

9

PROJECT NO: 2230-07-73 HWY: W. GREENFIELD AVENUE COUNTY: MILWAUKEE CROSS SECTIONS - W GREENFIELD AVENUE SHEET E

FILE NAME : X:\ML\2021\20210099\DESIGN\TRANSPORTATION\SHEETSPLAN\090201_XS.DWG PLOT DATE : 7/19/2023 2:16 PM PLOT BY : BIEBERITZ, BEN PLOT NAME : PLOT SCALE : 1 IN:20 FT HORZ. / 1 IN:10 FT VERT. WISDOT/CADD SHEET 49

LAYOUT NAME - 090206_xs

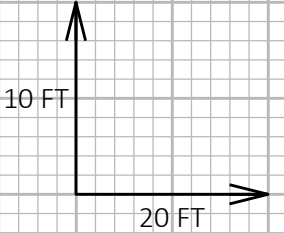
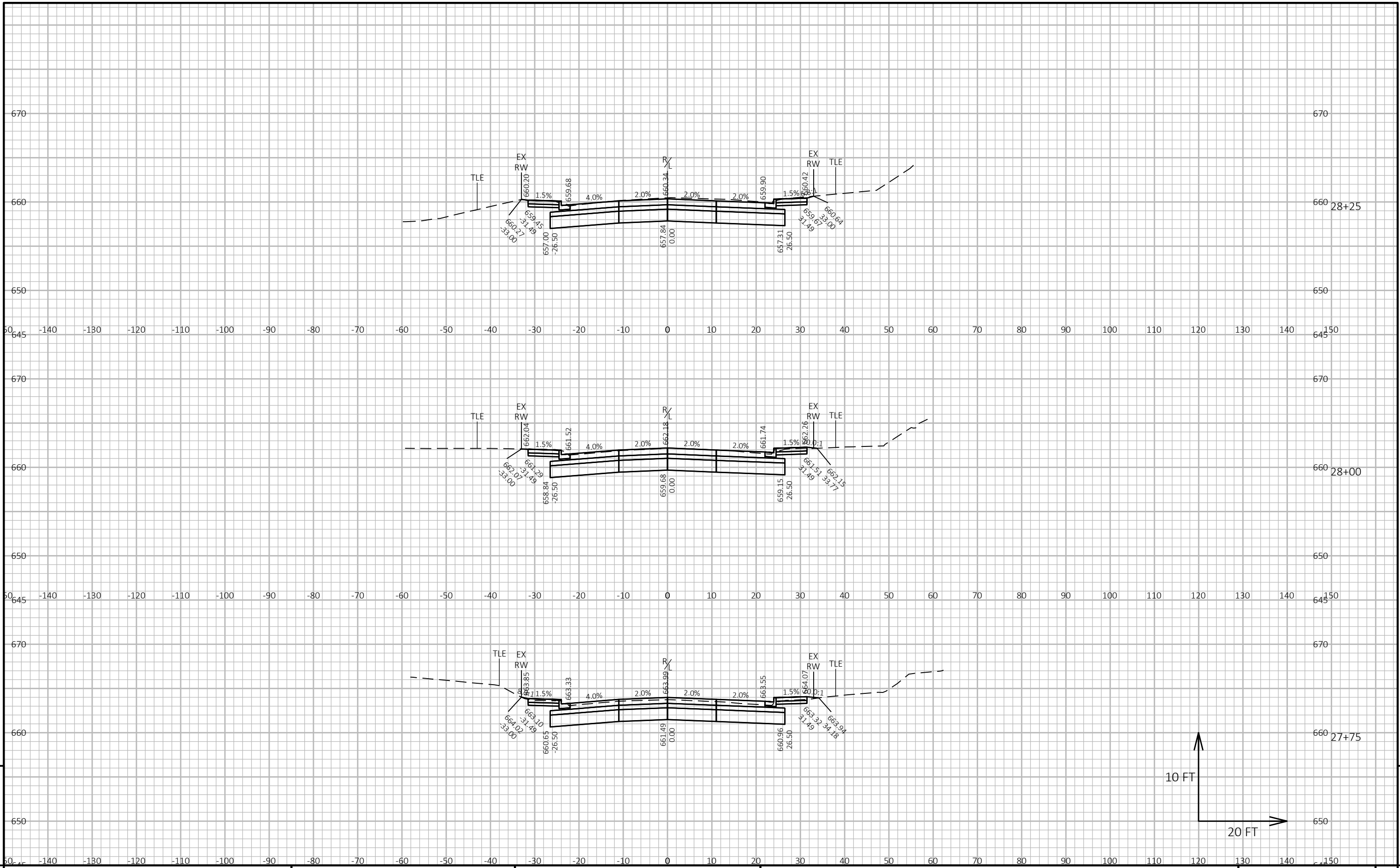

9

9

PROJECT NO: 2230-07-73 HWY: W. GREENFIELD AVENUE COUNTY: MILWAUKEE CROSS SECTIONS - W GREENFIELD AVENUE SHEET E

FILE NAME : X:\ML\2021\20210099\DESIGN\TRANSPORTATION\SHEETS\PLAN\090201_XS.DWG PLOT DATE : 7/19/2023 2:16 PM PLOT BY : BIEBERITZ, BEN PLOT NAME : PLOT SCALE : 1 IN:20 FT HORZ. / 1 IN:10 FT VERT. WISDOT/CADD SHEET 49

LAYOUT NAME - 090207_xs

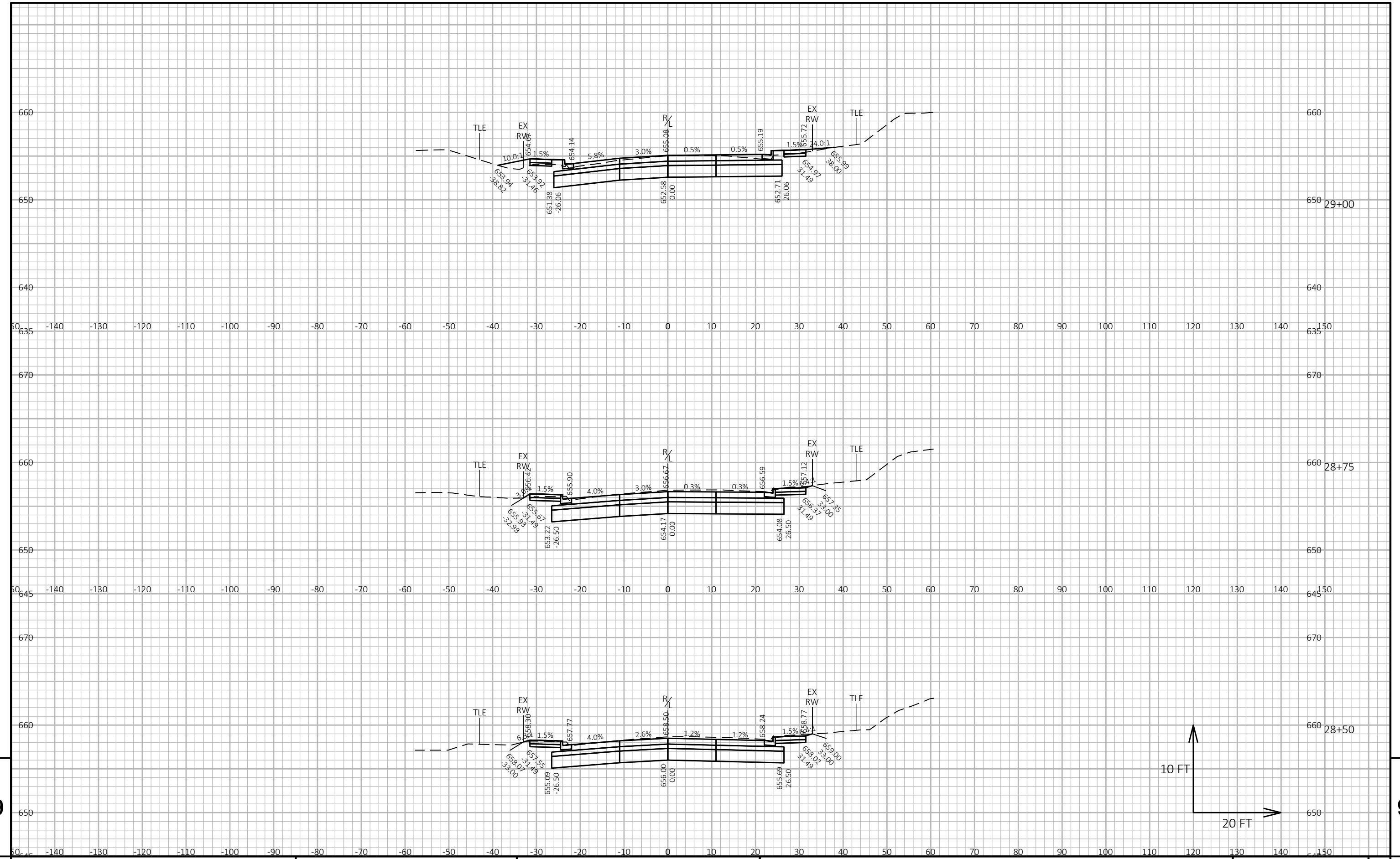

9

9

PROJECT NO: 2230-07-73 HWY: W. GREENFIELD AVENUE COUNTY: MILWAUKEE CROSS SECTIONS - W GREENFIELD AVENUE SHEET E

FILE NAME : X:\ML\2021\20210099\DESIGN\TRANSPORTATION\SHEETSPLAN\090201_XS.DWG PLOT DATE : 7/19/2023 2:16 PM PLOT BY : BIEBERITZ, BEN PLOT NAME : PLOT SCALE : 1 IN:20 FT HORZ. / 1 IN:10 FT VERT. WISDOT/CADD SHEET 49

LAYOUT NAME - 090208_xs

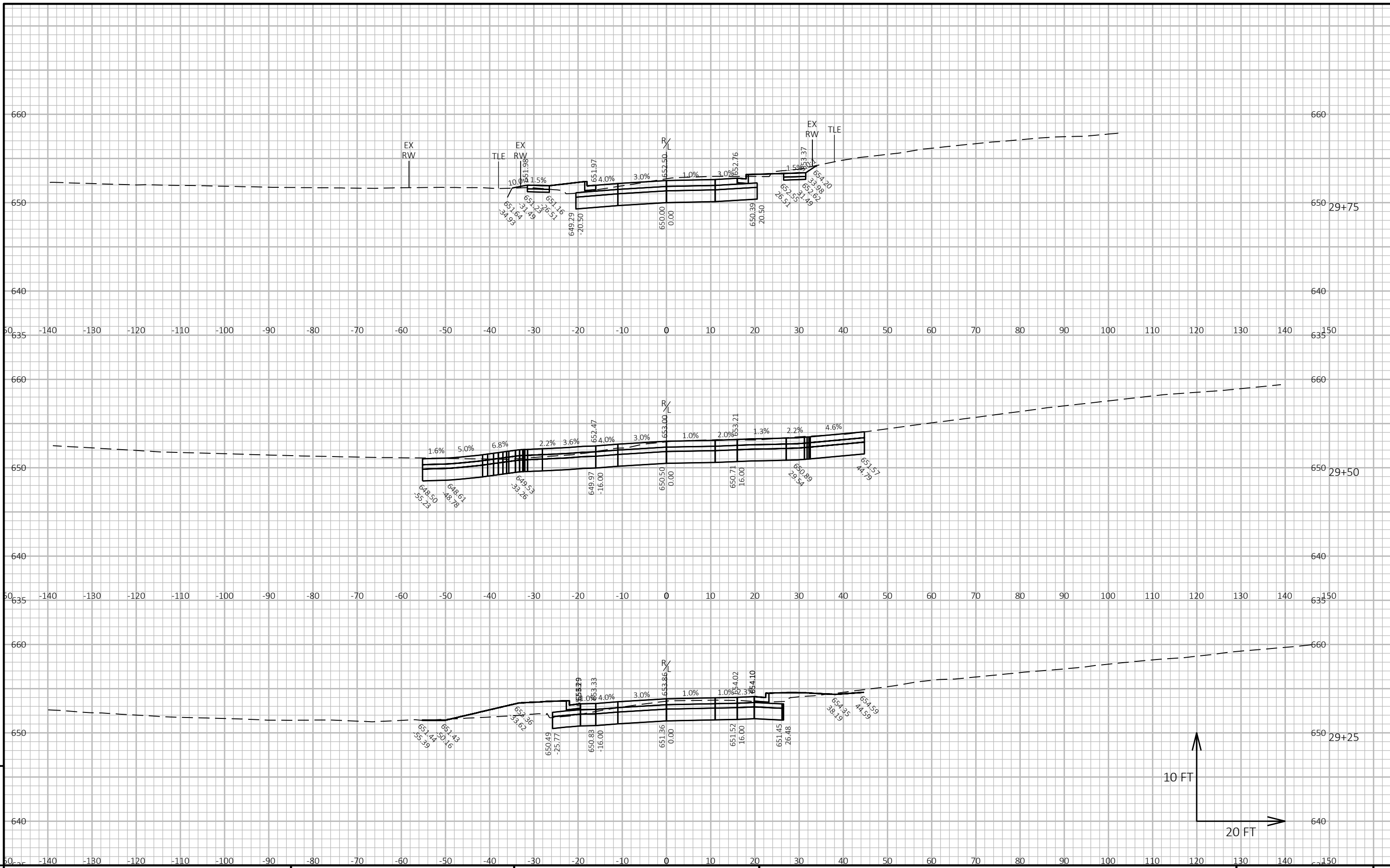

PROJECT NO: 2230-07-73

HWY: W. GREENFIELD AVENUE

COUNTY: MILWAUKEE

CROSS SECTIONS - W GREENFIELD AVENUE

SHEET

E

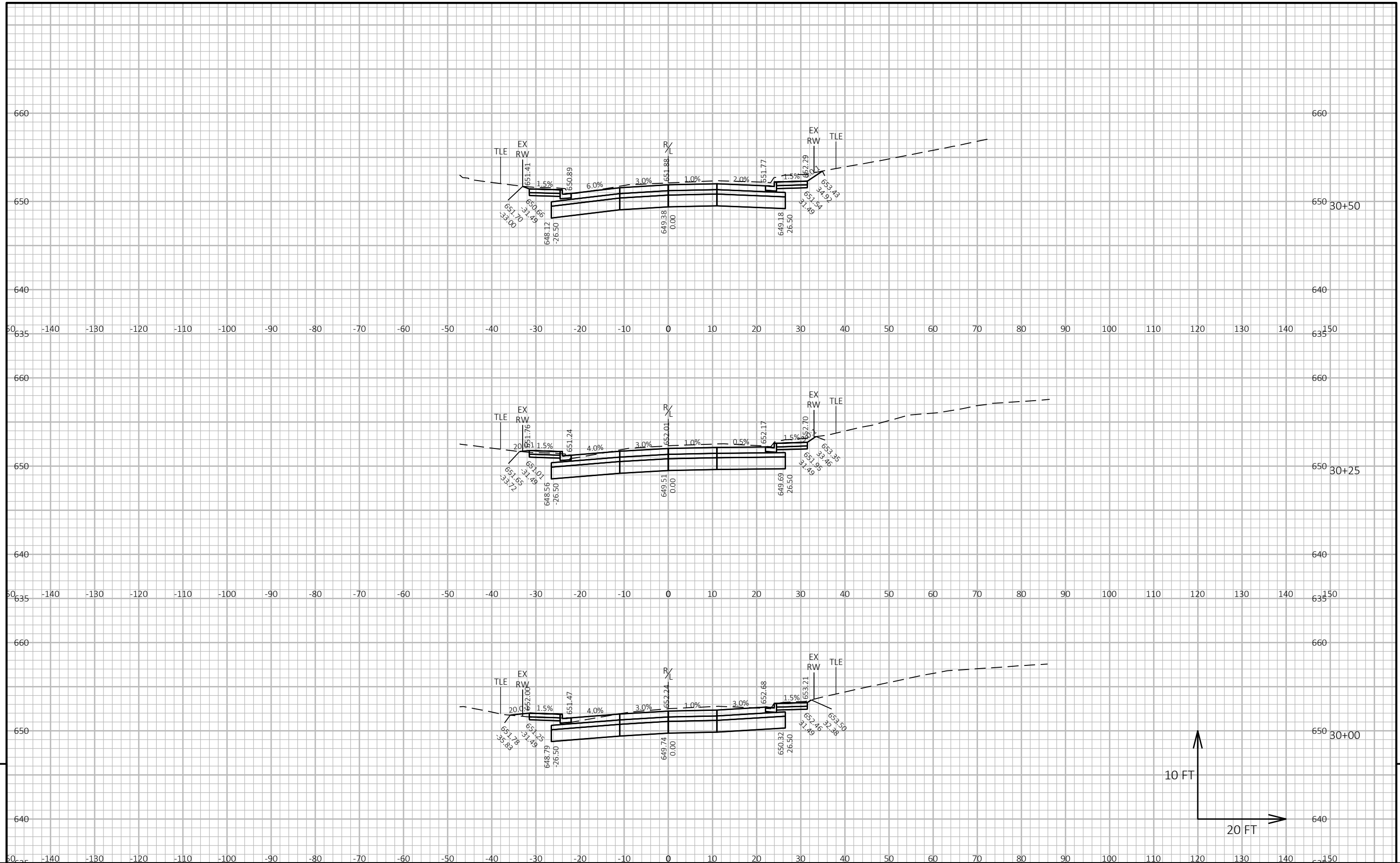

PROJECT NO: 2230-07-73

HWY: W. GREENFIELD AVENUE

COUNTY: MILWAUKEE

CROSS SECTIONS - W GREENFIELD AVENUE

SHEET

E

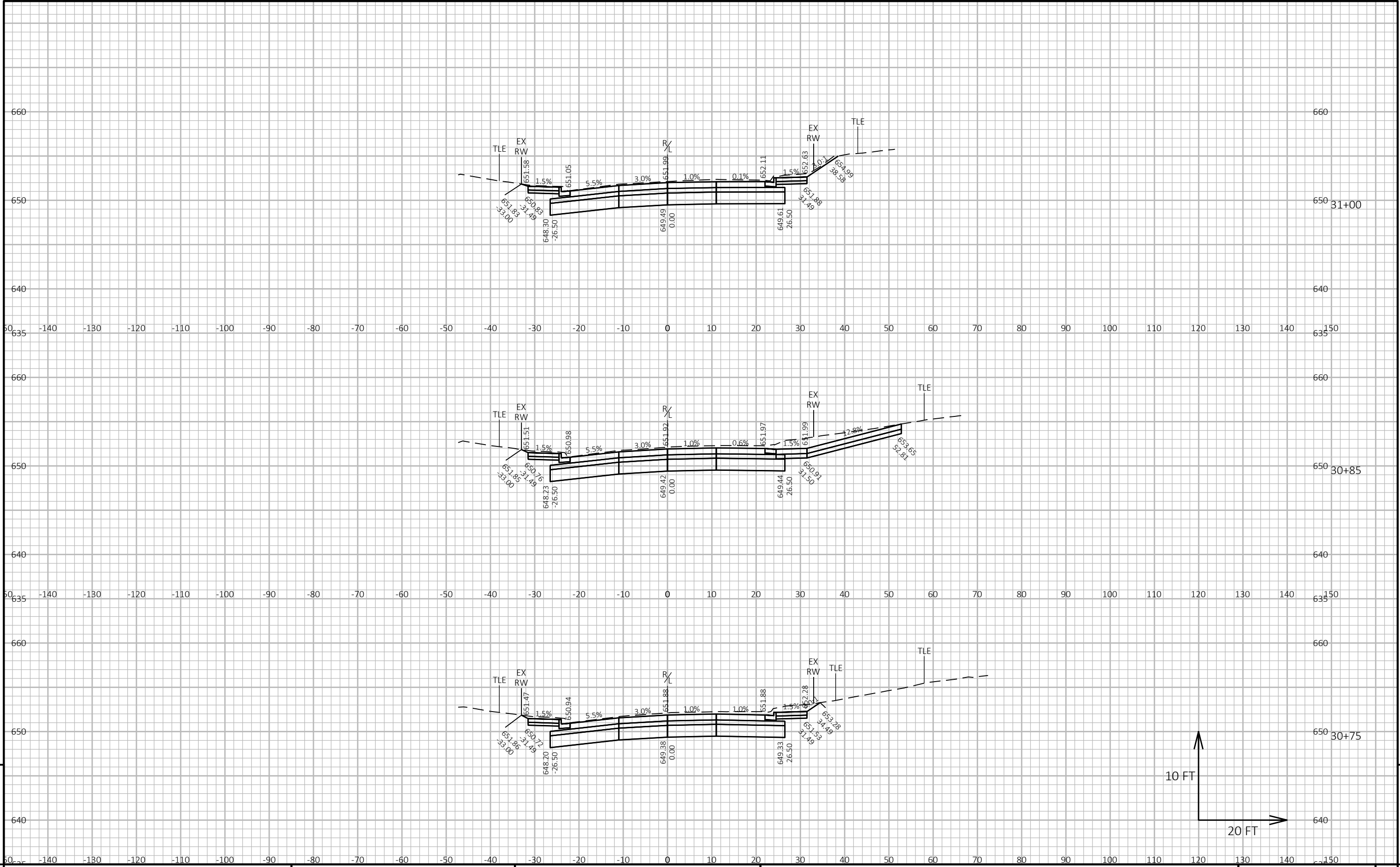

9
PROJECT NO: 2230-07-73
HWY: W. GREENFIELD AVENUE
COUNTY: MILWAUKEE
CROSS SECTIONS - W GREENFIELD AVENUE
SHEET
9

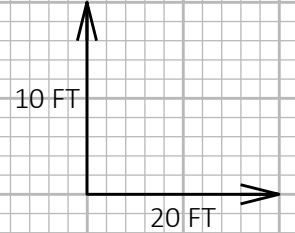
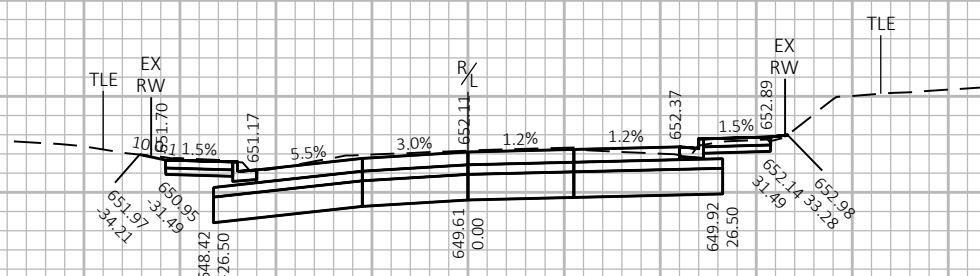
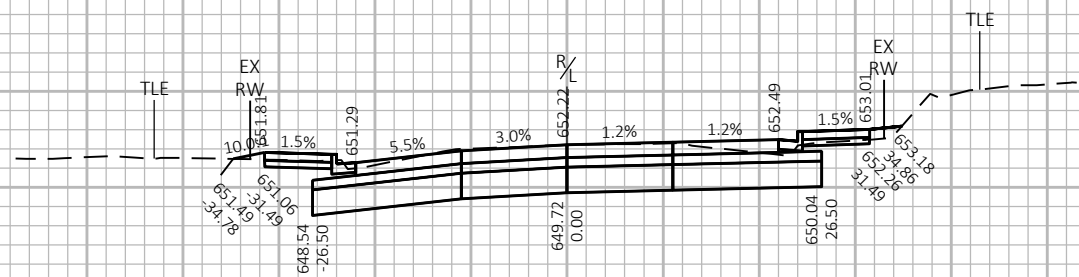
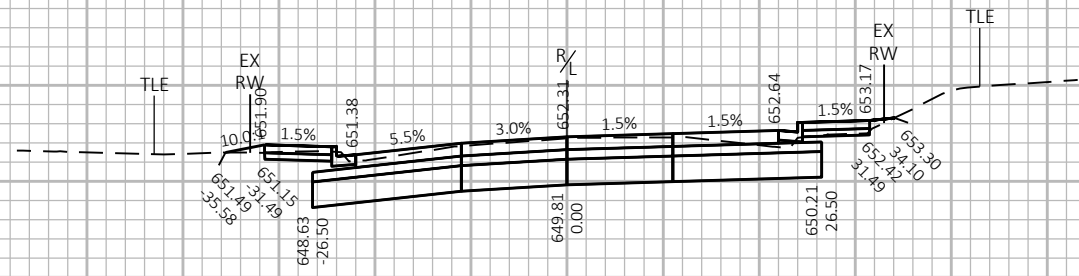

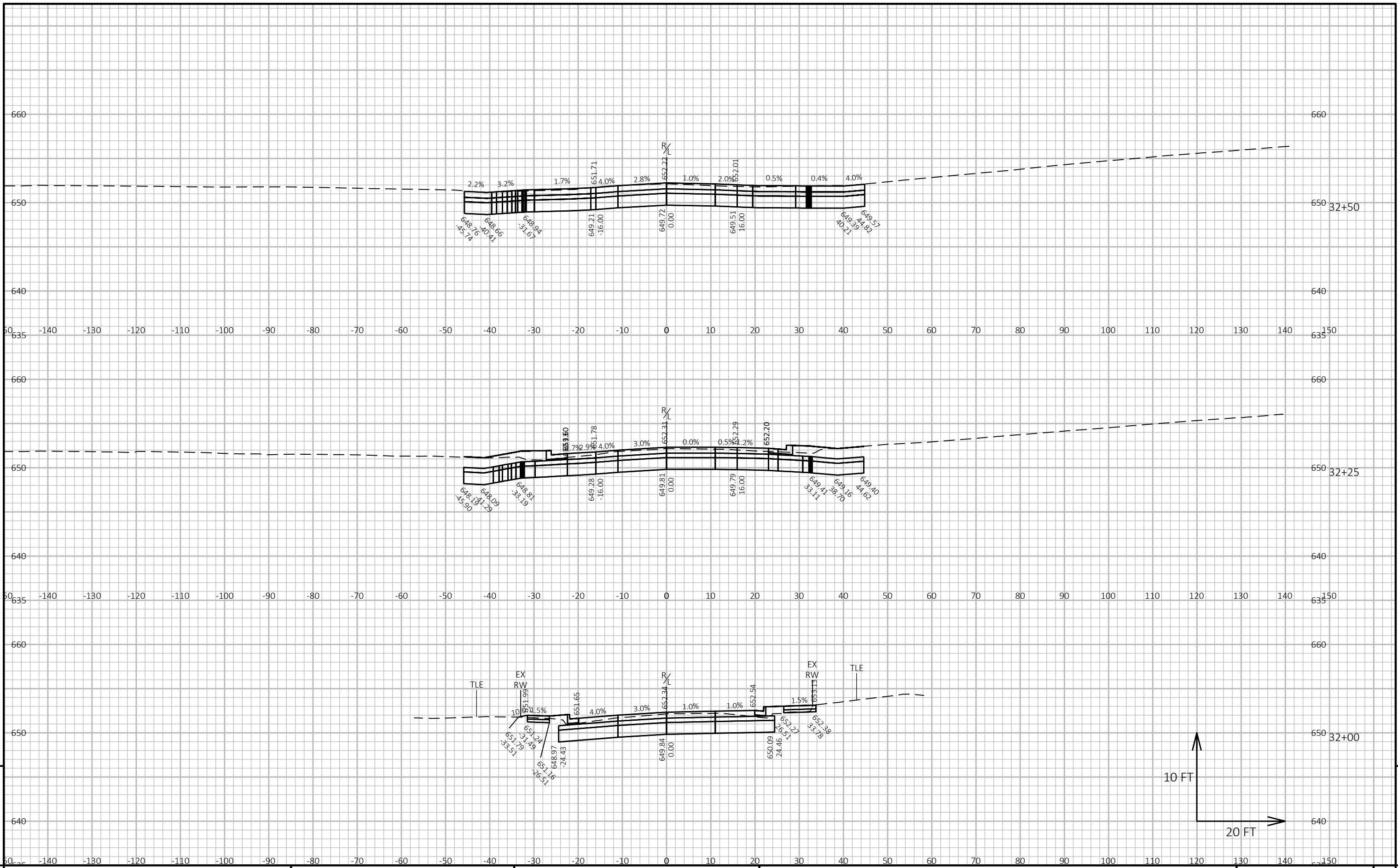

9

9

PROJECT NO: 2230-07-73 HWY: W. GREENFIELD AVENUE COUNTY: MILWAUKEE CROSS SECTIONS - W GREENFIELD AVENUE SHEET E

FILE NAME : X:\ML\2021\20210099\DESIGN\TRANSPORTATION\SHEETSPLAN\090201_XS.DWG PLOT DATE : 7/19/2023 2:17 PM PLOT BY : BIEBERITZ, BEN PLOT NAME : PLOT SCALE : 1 IN:20 FT HORZ. / 1 IN:10 FT VERT. WISDOT/CADD SHEET 49

LAYOUT NAME - 090213_xs

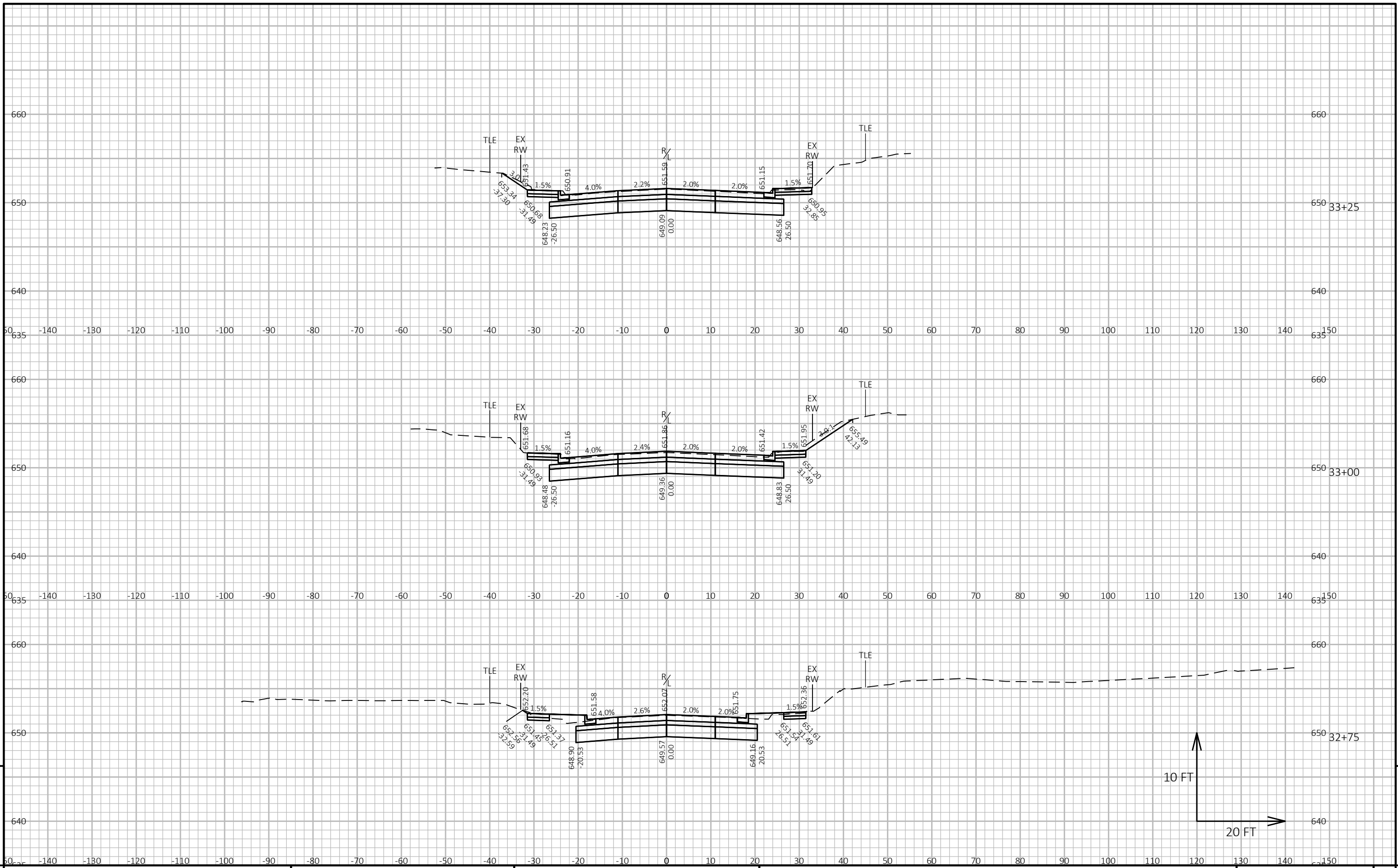

PROJECT NO: 2230-07-73

HWY: W. GREENFIELD AVENUE

COUNTY: MILWAUKEE

CROSS SECTIONS - W GREENFIELD AVENUE

SHEET

E

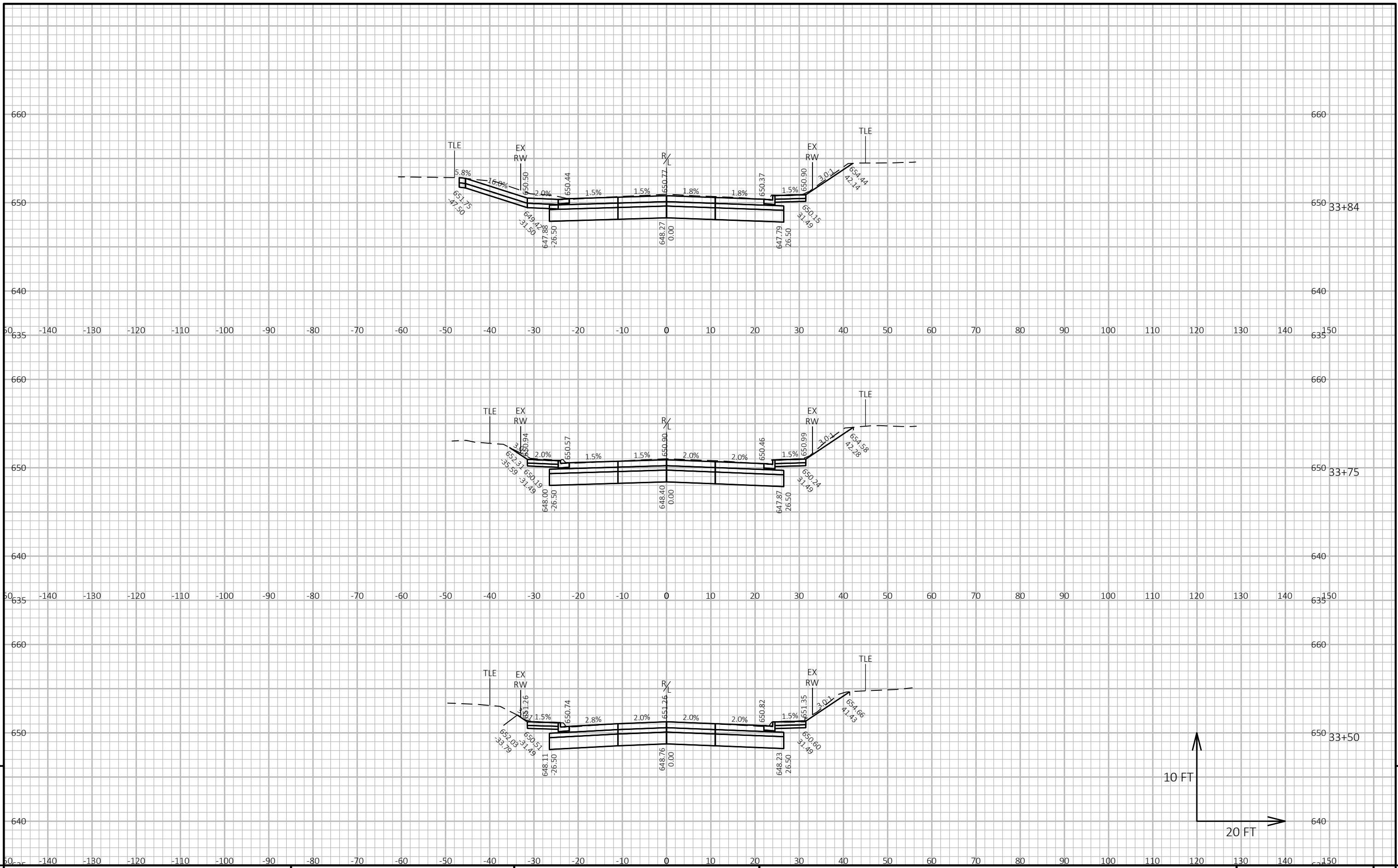

9

9

PROJECT NO: 2230-07-73 HWY: W. GREENFIELD AVENUE COUNTY: MILWAUKEE CROSS SECTIONS - W GREENFIELD AVENUE SHEET E

FILE NAME : X:\ML\2021\20210099\DESIGN\TRANSPORTATION\SHEETSPLAN\090201_XS.DWG PLOT DATE : 7/19/2023 2:17 PM PLOT BY : BIEBERITZ, BEN PLOT NAME : PLOT SCALE : 1 IN:20 FT HORZ. / 1 IN:10 FT VERT. WISDOT/CADD SHEET 49

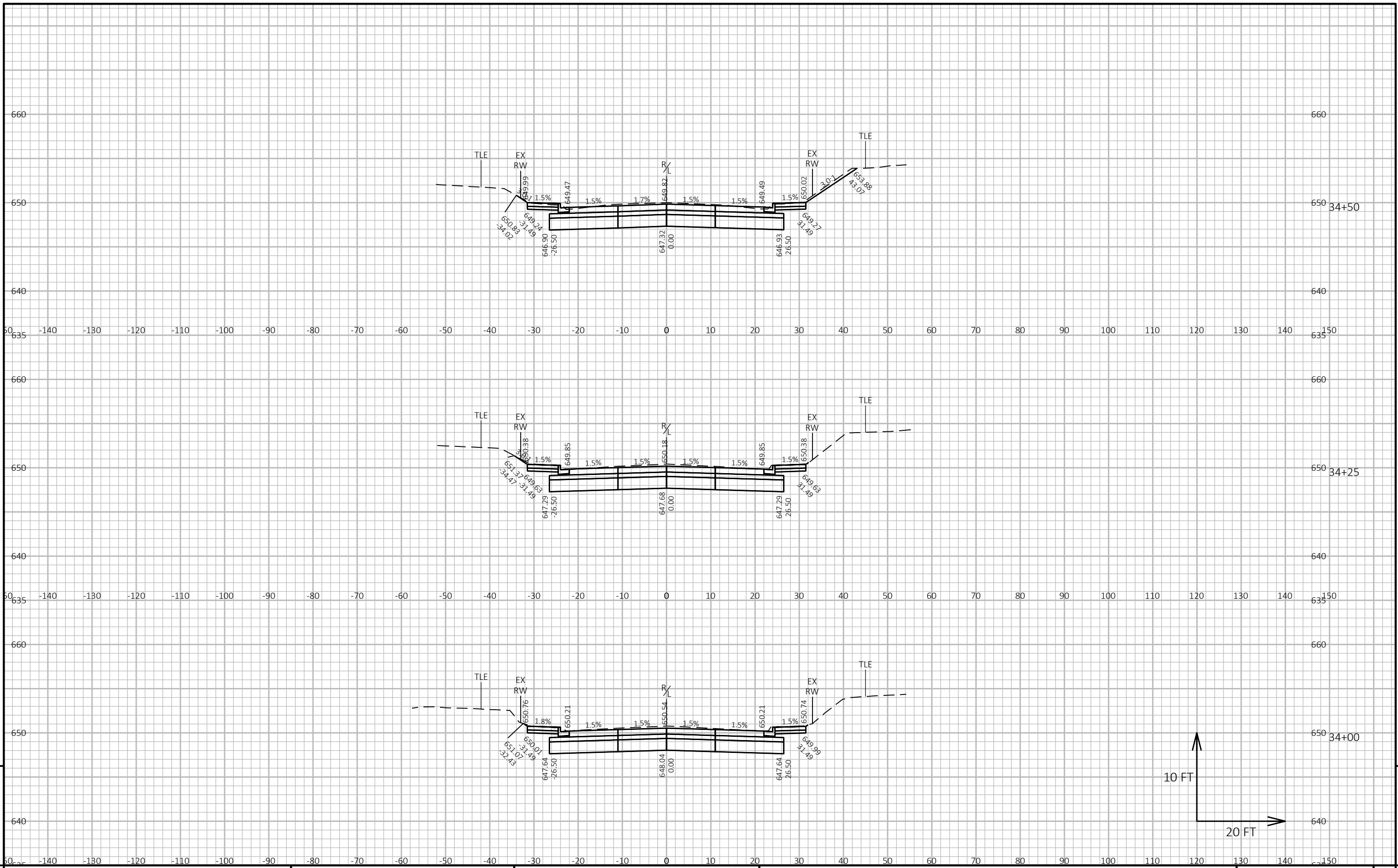

9

9

PROJECT NO: 2230-07-73 HWY: W. GREENFIELD AVENUE COUNTY: MILWAUKEE CROSS SECTIONS - W GREENFIELD AVENUE SHEET E

FILE NAME : X:\ML\2021\20210099\DESIGN\TRANSPORTATION\SHEETSPLAN\090201_XS.DWG PLOT DATE : 7/19/2023 2:17 PM PLOT BY : BIEBERITZ, BEN PLOT NAME : PLOT SCALE : 1 IN:20 FT HORZ. / 1 IN:10 FT VERT. WISDOT/CADD SHEET 49

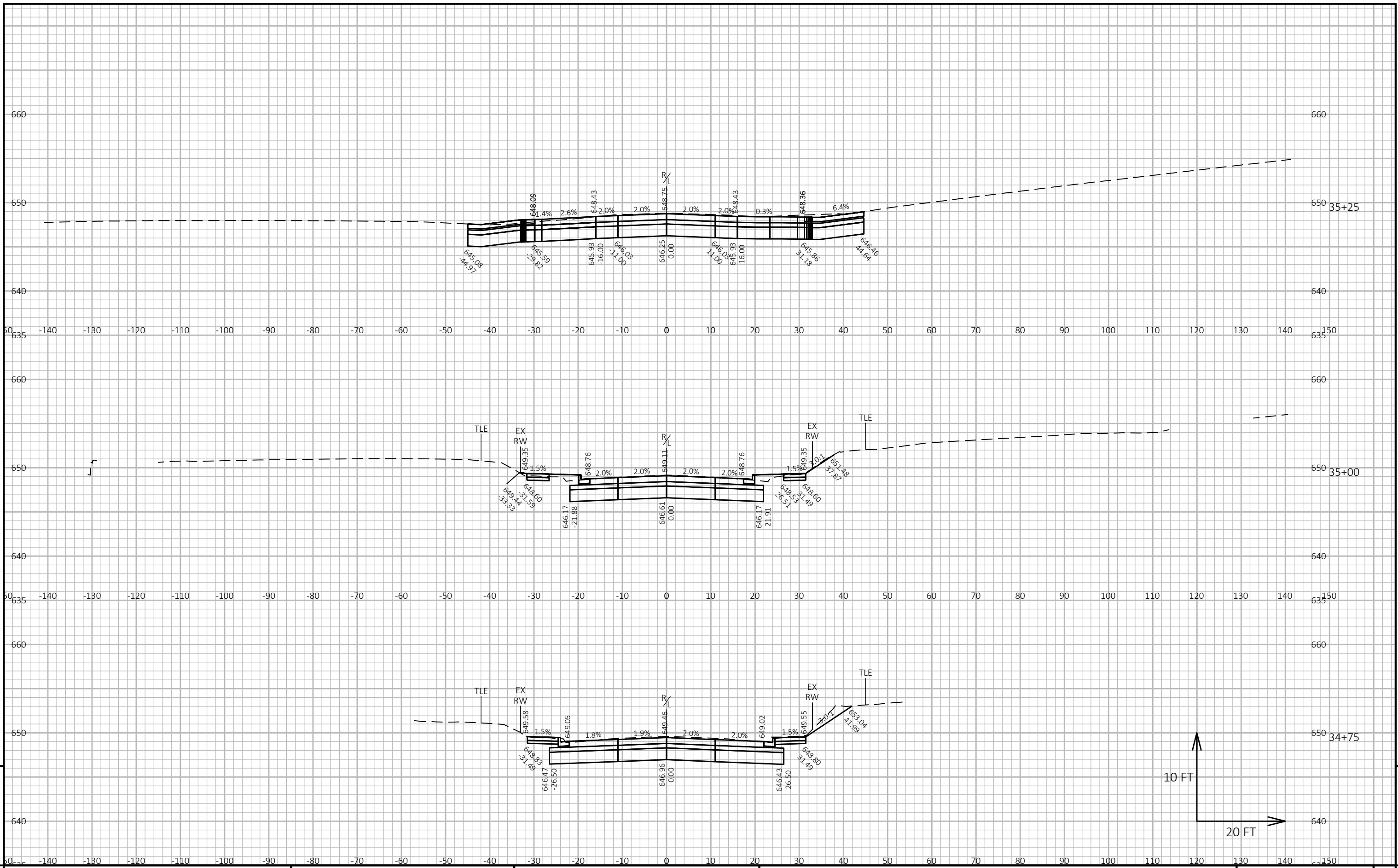

PROJECT NO: 2230-07-73 HWY: W. GREENFIELD AVENUE COUNTY: MILWAUKEE CROSS SECTIONS - W GREENFIELD AVENUE SHEET E

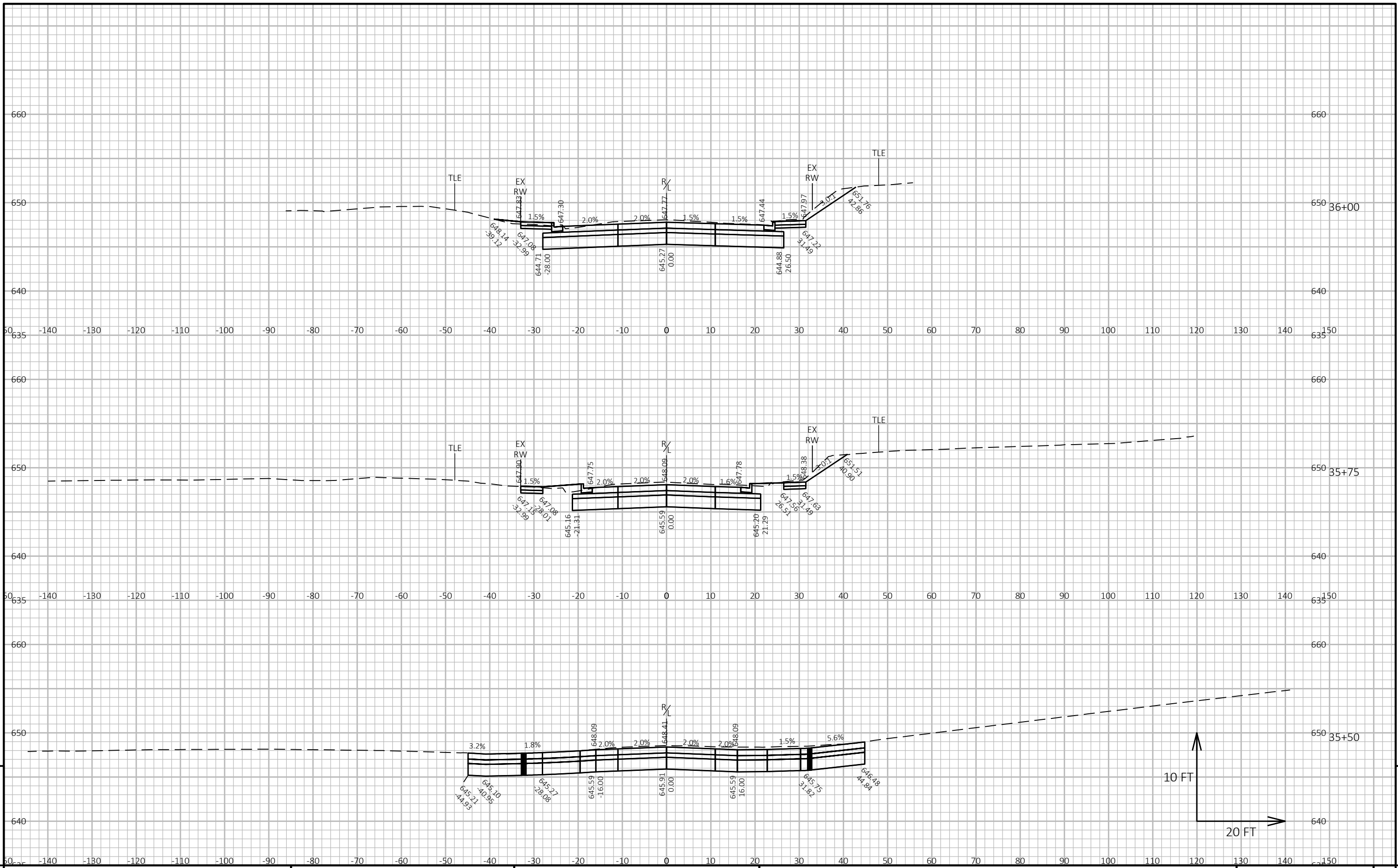

PROJECT NO: 2230-07-73 HWY: W. GREENFIELD AVENUE COUNTY: MILWAUKEE CROSS SECTIONS - W GREENFIELD AVENUE SHEET E

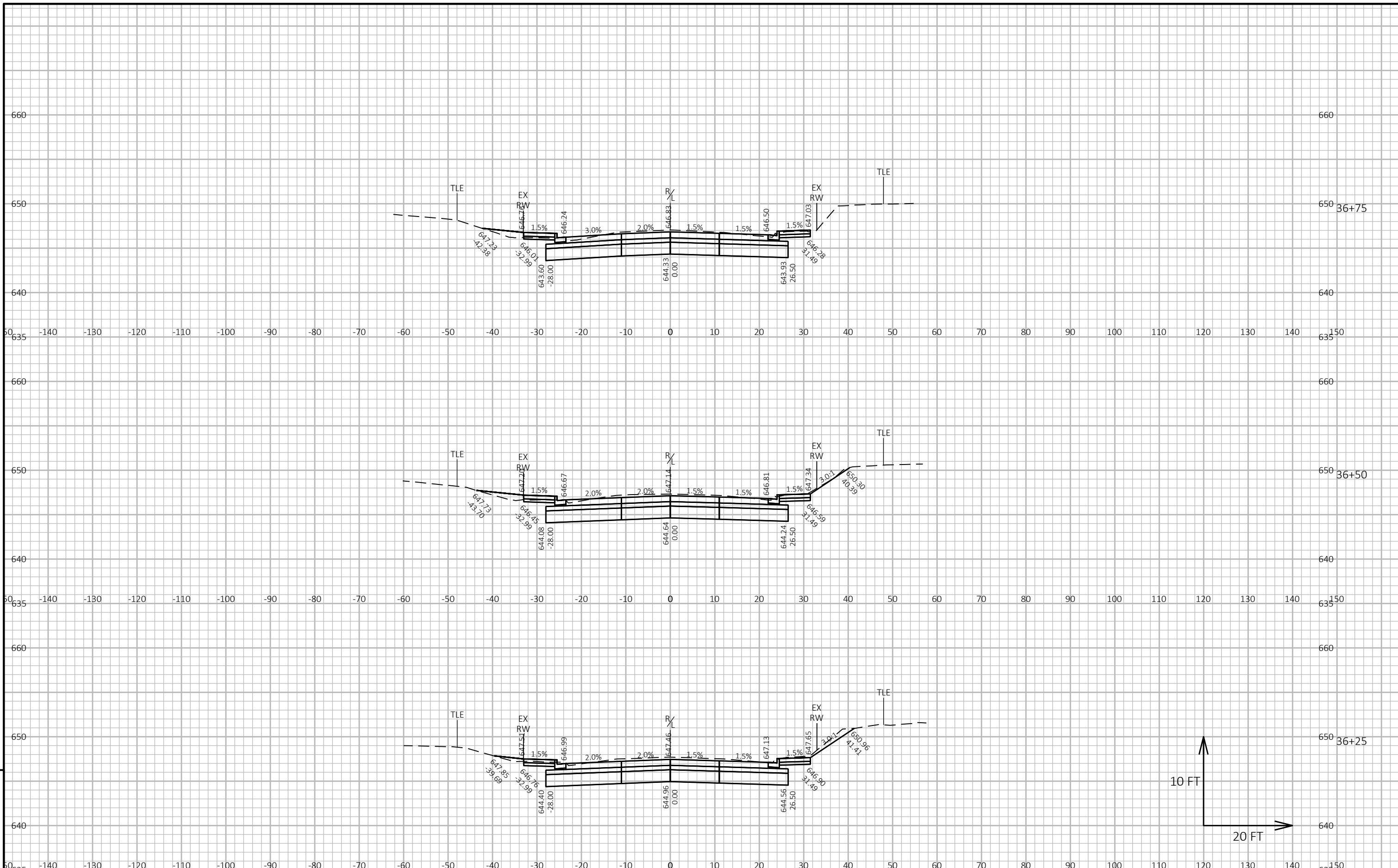

9

9

PROJECT NO: 2230-07-73 HWY: W. GREENFIELD AVENUE COUNTY: MILWAUKEE CROSS SECTIONS - W GREENFIELD AVENUE SHEET E

FILE NAME : X:\ML\2021\20210099\DESIGN\TRANSPORTATION\SHEETSPLAN\090201_XS.DWG PLOT DATE : 7/19/2023 2:17 PM PLOT BY : BIEBERITZ, BEN PLOT NAME : PLOT SCALE : 1 IN:20 FT HORZ. / 1 IN:10 FT VERT. WISDOT/CADD SHEET 49

LAYOUT NAME - 090219_xs

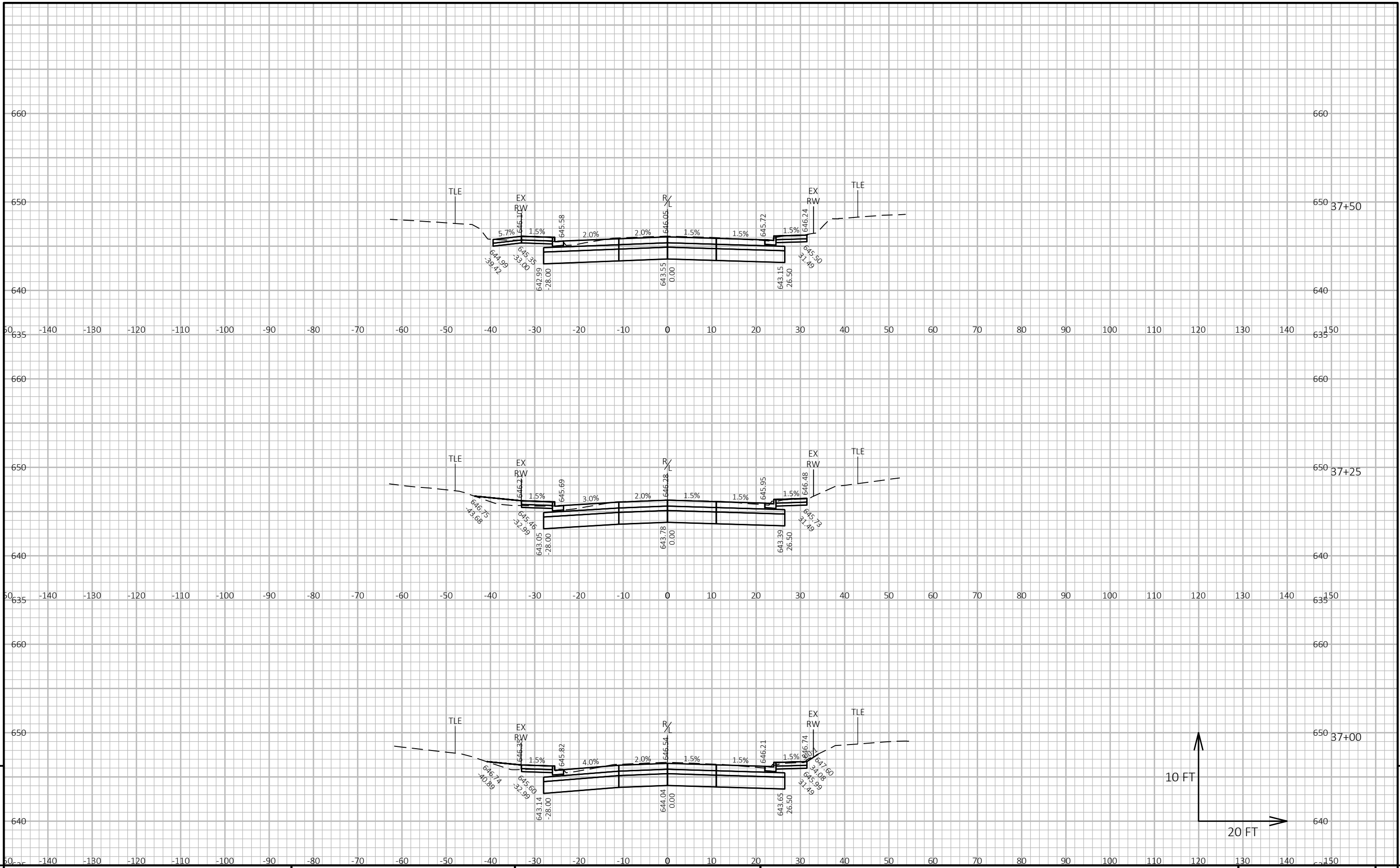

PROJECT NO: 2230-07-73

HWY: W. GREENFIELD AVENUE

COUNTY: MILWAUKEE

CROSS SECTIONS - W GREENFIELD AVENUE

SHEET

E

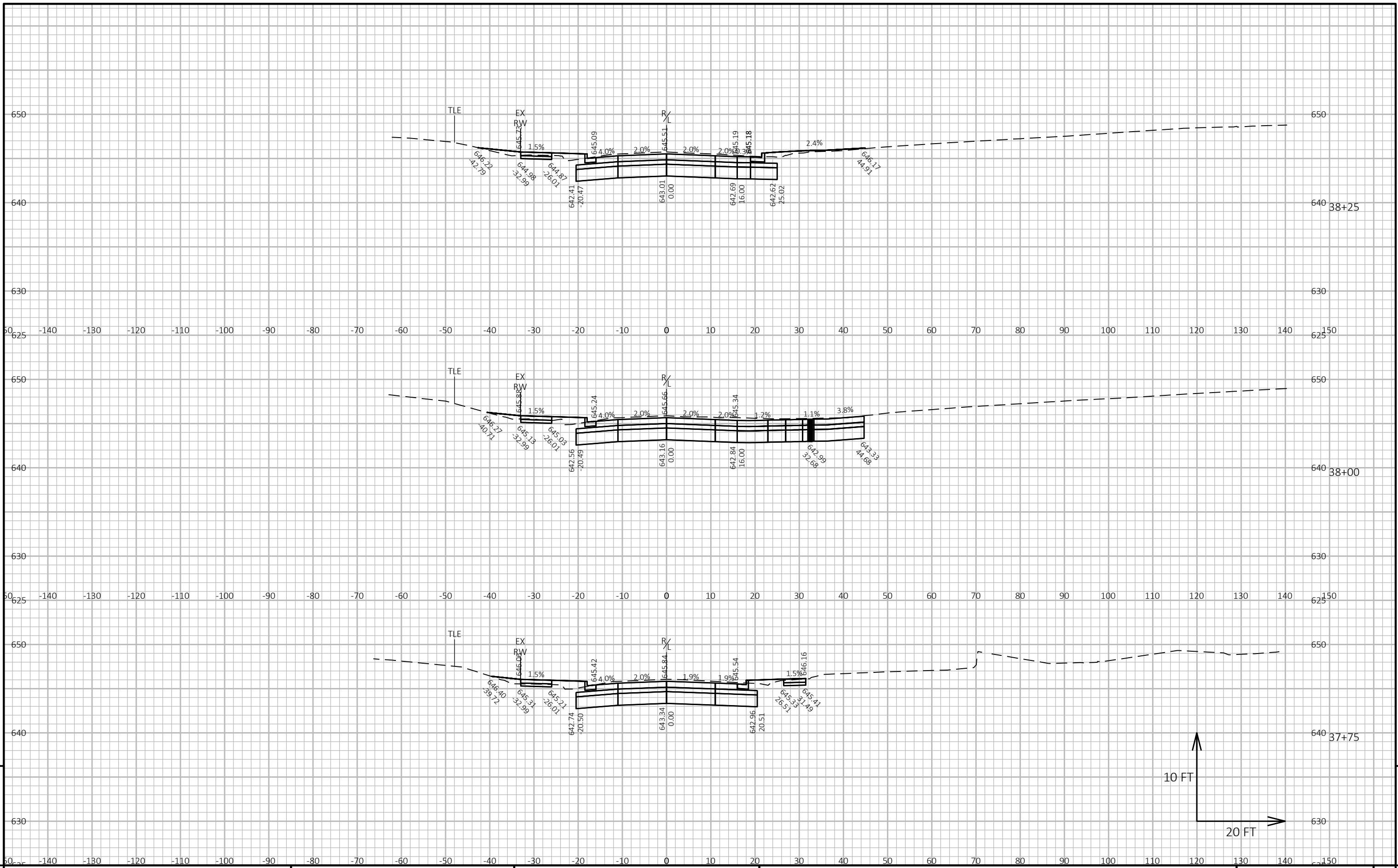

9

9

PROJECT NO: 2230-07-73 HWY: W. GREENFIELD AVENUE COUNTY: MILWAUKEE CROSS SECTIONS - W GREENFIELD AVENUE SHEET E

FILE NAME : X:\ML\2021\20210099\DESIGN\TRANSPORTATION\SHEETSPLAN\090201_XS.DWG PLOT DATE : 7/19/2023 2:18 PM PLOT BY : BIEBERITZ, BEN PLOT NAME : PLOT SCALE : 1 IN:20 FT HORZ. / 1 IN:10 FT VERT. WISDOT/CADD SHEET 49

LAYOUT NAME - 090221_xs

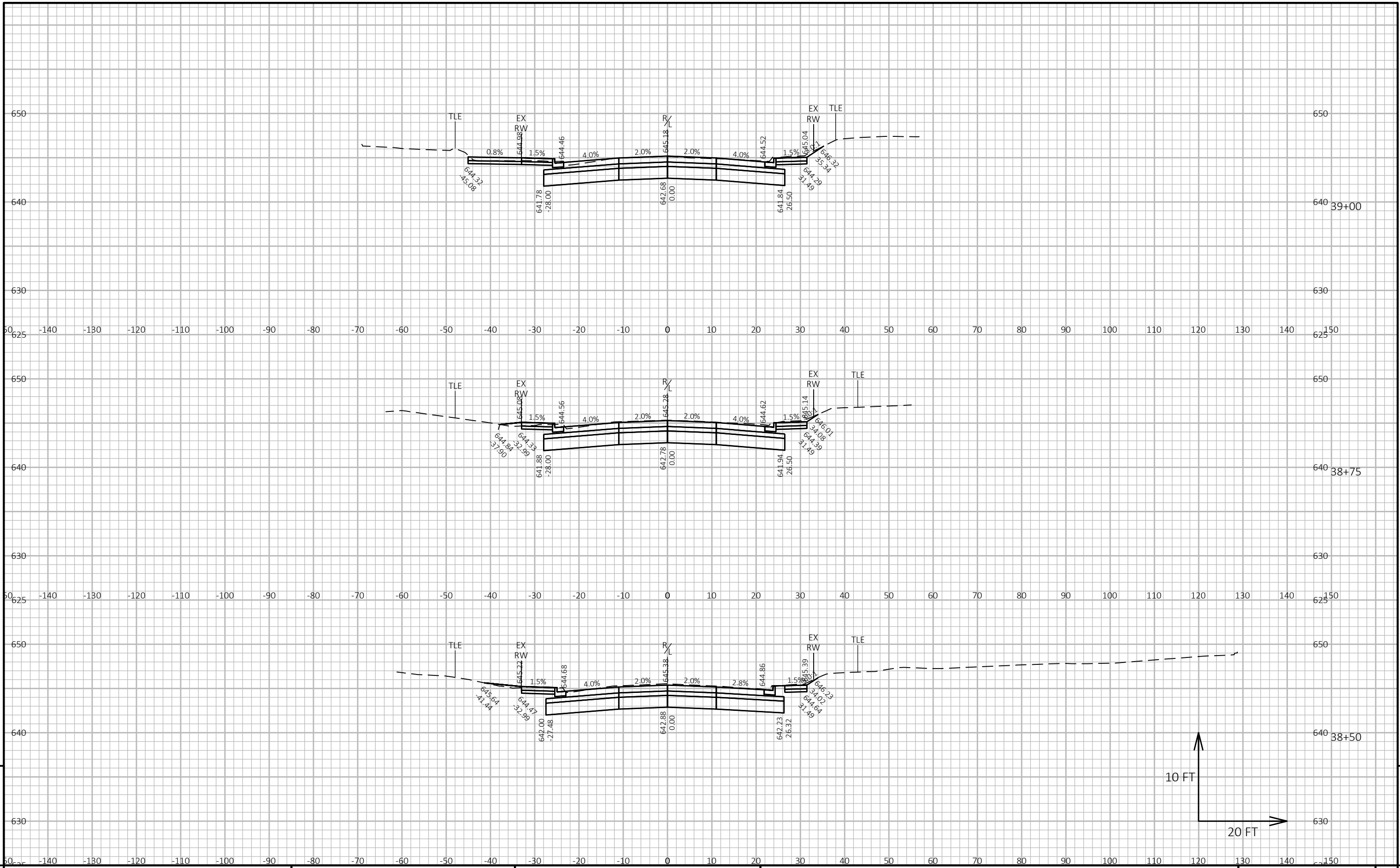

9

9

PROJECT NO: 2230-07-73 HWY: W. GREENFIELD AVENUE COUNTY: MILWAUKEE CROSS SECTIONS - W GREENFIELD AVENUE SHEET E

FILE NAME : X:\ML\2021\20210099\DESIGN\TRANSPORTATION\SHEETSPLAN\090201_XS.DWG PLOT DATE : 7/19/2023 2:18 PM PLOT BY : BIEBERITZ, BEN PLOT NAME : PLOT SCALE : 1 IN:20 FT HORZ. / 1 IN:10 FT VERT. WISDOT/CADD SHEET 49

LAYOUT NAME - 090222_xs

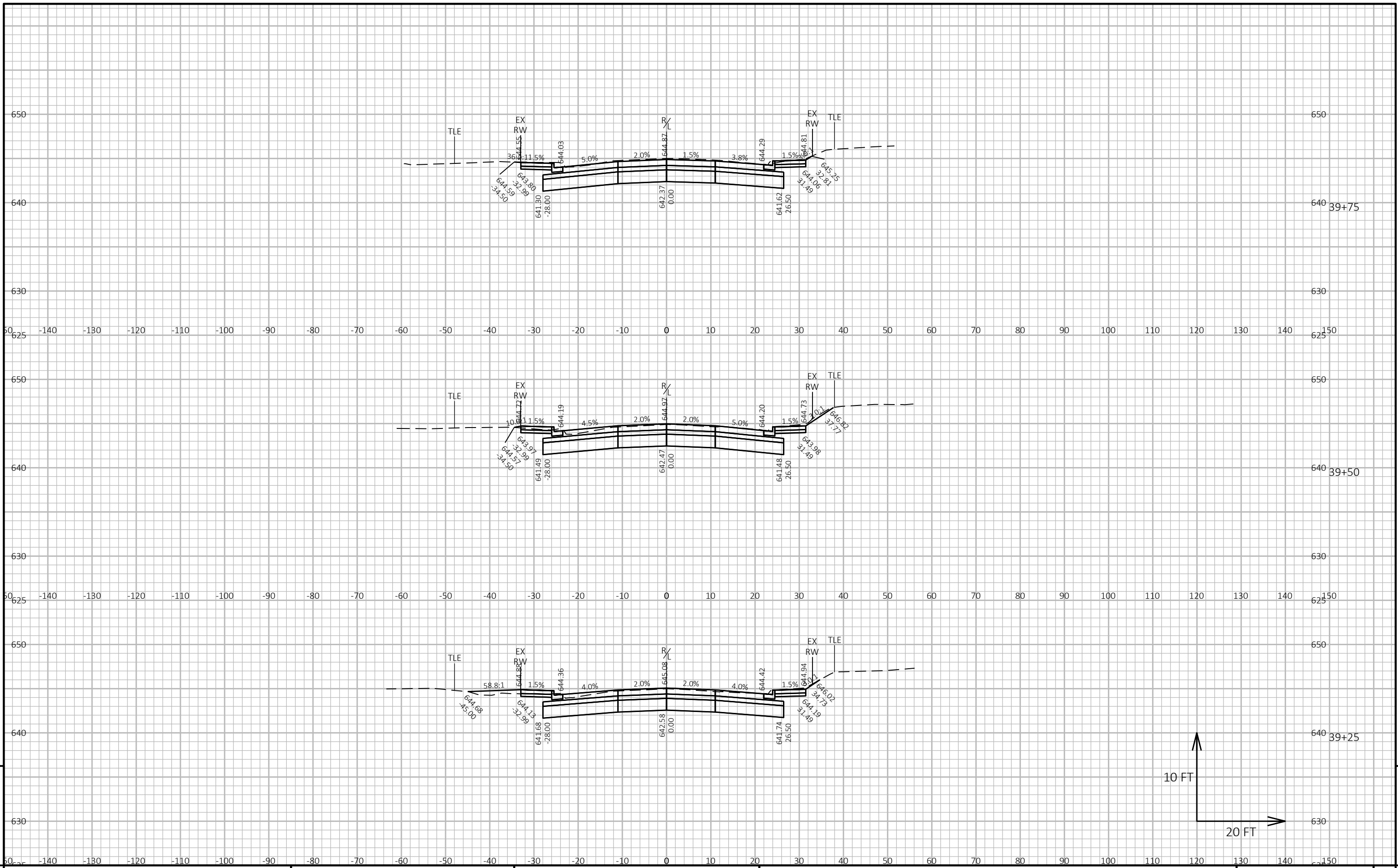

9

9

PROJECT NO: 2230-07-73 HWY: W. GREENFIELD AVENUE COUNTY: MILWAUKEE CROSS SECTIONS - W GREENFIELD AVENUE SHEET E

FILE NAME : X:\ML\2021\20210099\DESIGN\TRANSPORTATION\SHEETSPLAN\090201_XS.DWG PLOT DATE : 7/19/2023 2:18 PM PLOT BY : BIEBERITZ, BEN PLOT NAME : PLOT SCALE : 1 IN:20 FT HORZ. / 1 IN:10 FT VERT. WISDOT/CADD SHEET 49

LAYOUT NAME - 090223_xs

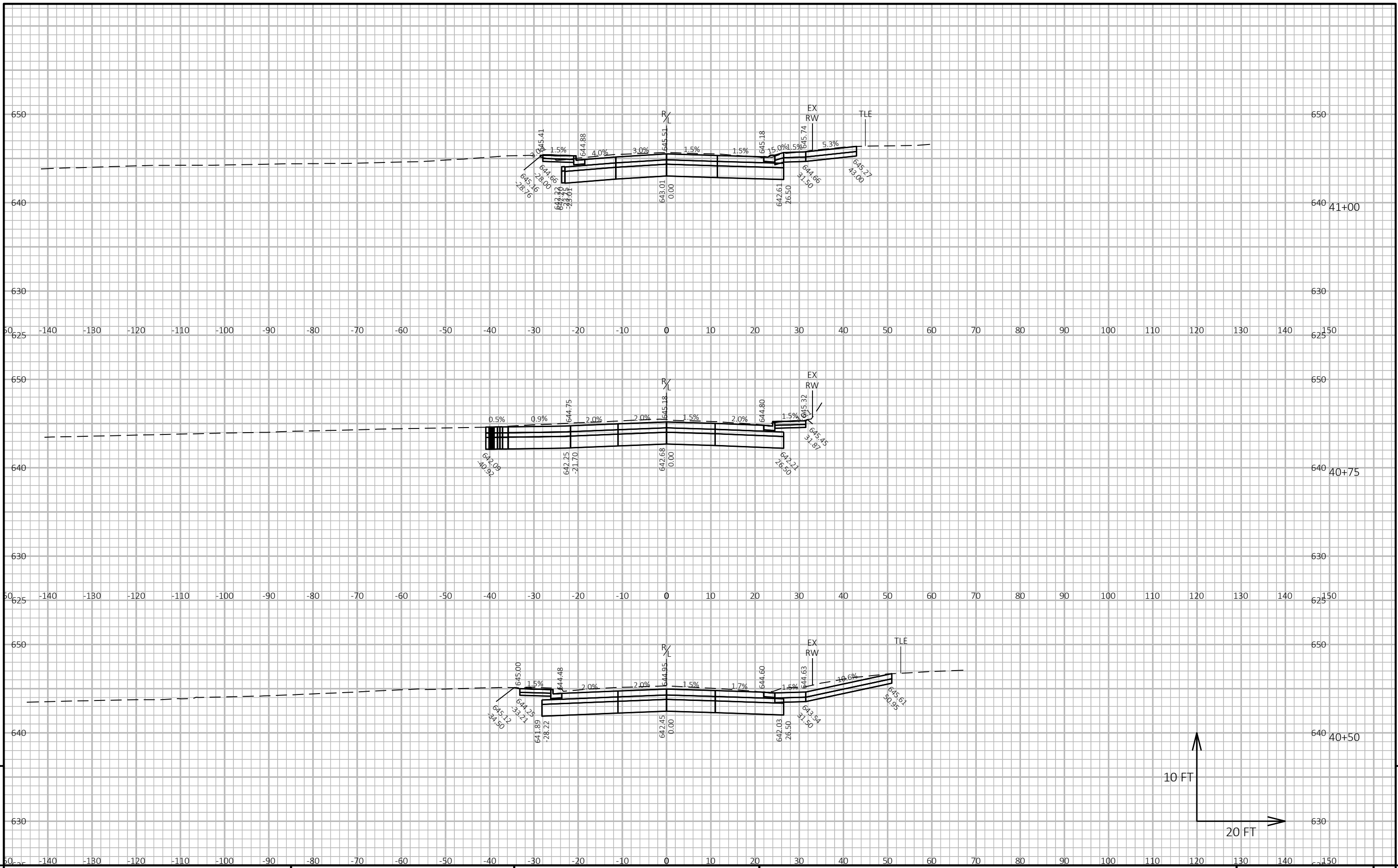

9

9

PROJECT NO: 2230-07-73 HWY: W. GREENFIELD AVENUE COUNTY: MILWAUKEE CROSS SECTIONS - W GREENFIELD AVENUE SHEET E

FILE NAME : X:\ML\2021\20210099\DESIGN\TRANSPORTATION\SHEETSPLAN\090201_XS.DWG PLOT DATE : 7/19/2023 2:18 PM PLOT BY : BIEBERITZ, BEN PLOT NAME : PLOT SCALE : 1 IN:20 FT HORZ. / 1 IN:10 FT VERT. WISDOT/CADD SHEET 49

LAYOUT NAME - 090225_xs

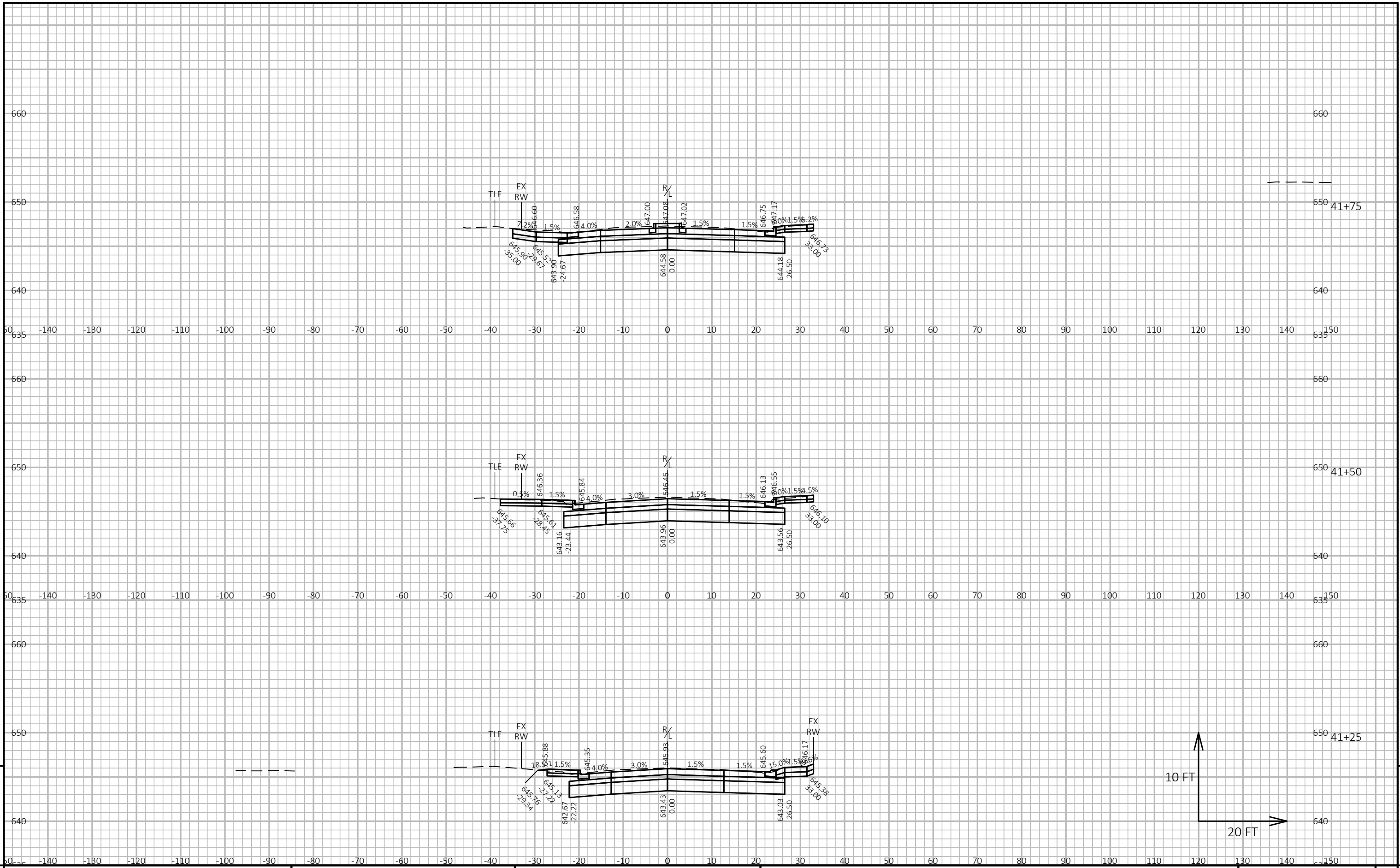

9

9

PROJECT NO: 2230-07-73 HWY: W. GREENFIELD AVENUE COUNTY: MILWAUKEE CROSS SECTIONS - W GREENFIELD AVENUE SHEET E

FILE NAME : X:\ML\2021\20210099\DESIGN\TRANSPORTATION\SHEETSPLAN\090201_XS.DWG PLOT DATE : 7/19/2023 2:18 PM PLOT BY : BIEBERITZ, BEN PLOT NAME : PLOT SCALE : 1 IN:20 FT HORZ. / 1 IN:10 FT VERT. WISDOT/CADD SHEET 49

LAYOUT NAME - 090226_xs

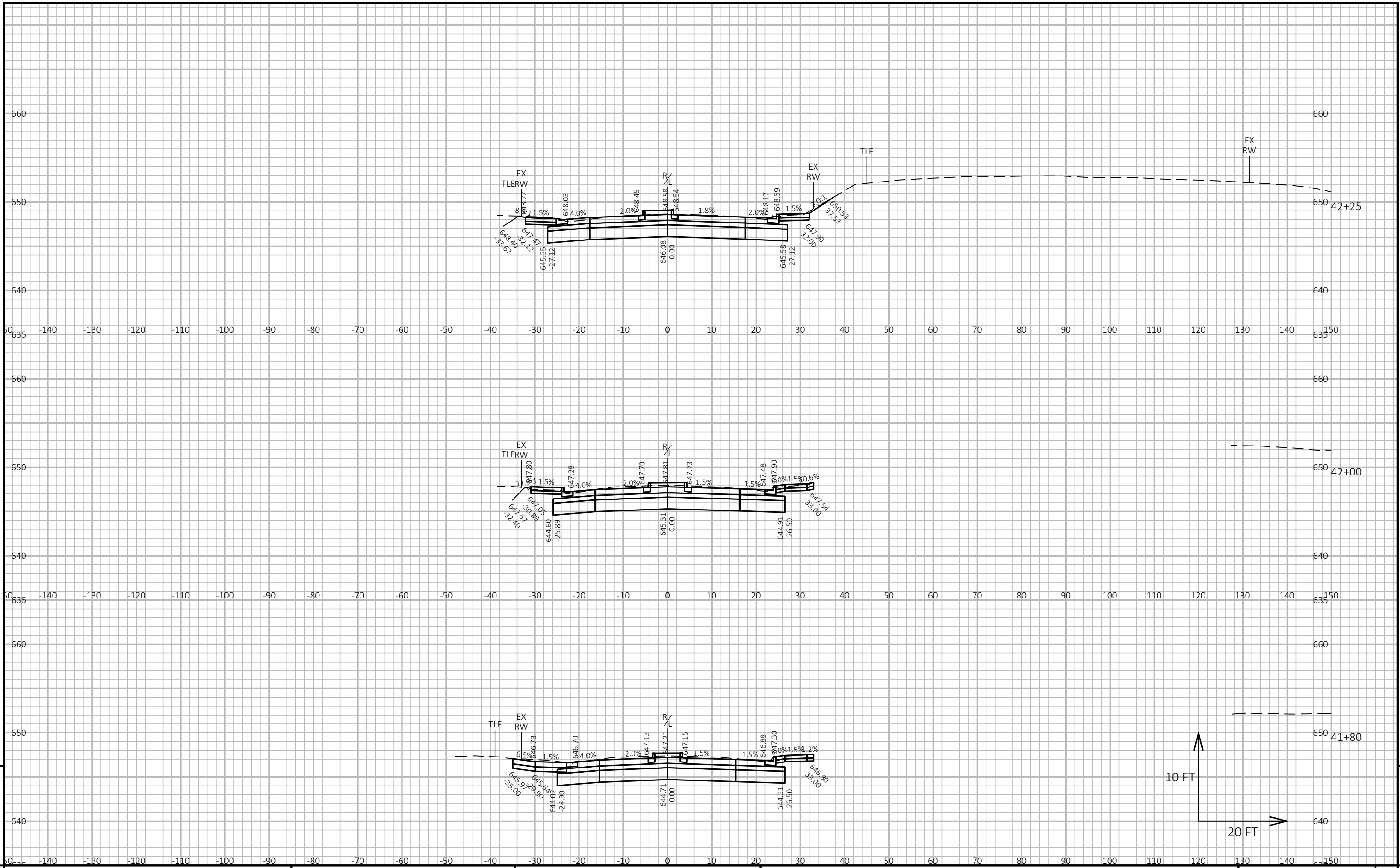

PROJECT NO: 2230-07-73

HWY: W. GREENFIELD AVENUE

COUNTY: MILWAUKEE

CROSS SECTIONS - W GREENFIELD AVENUE

SHEET

E

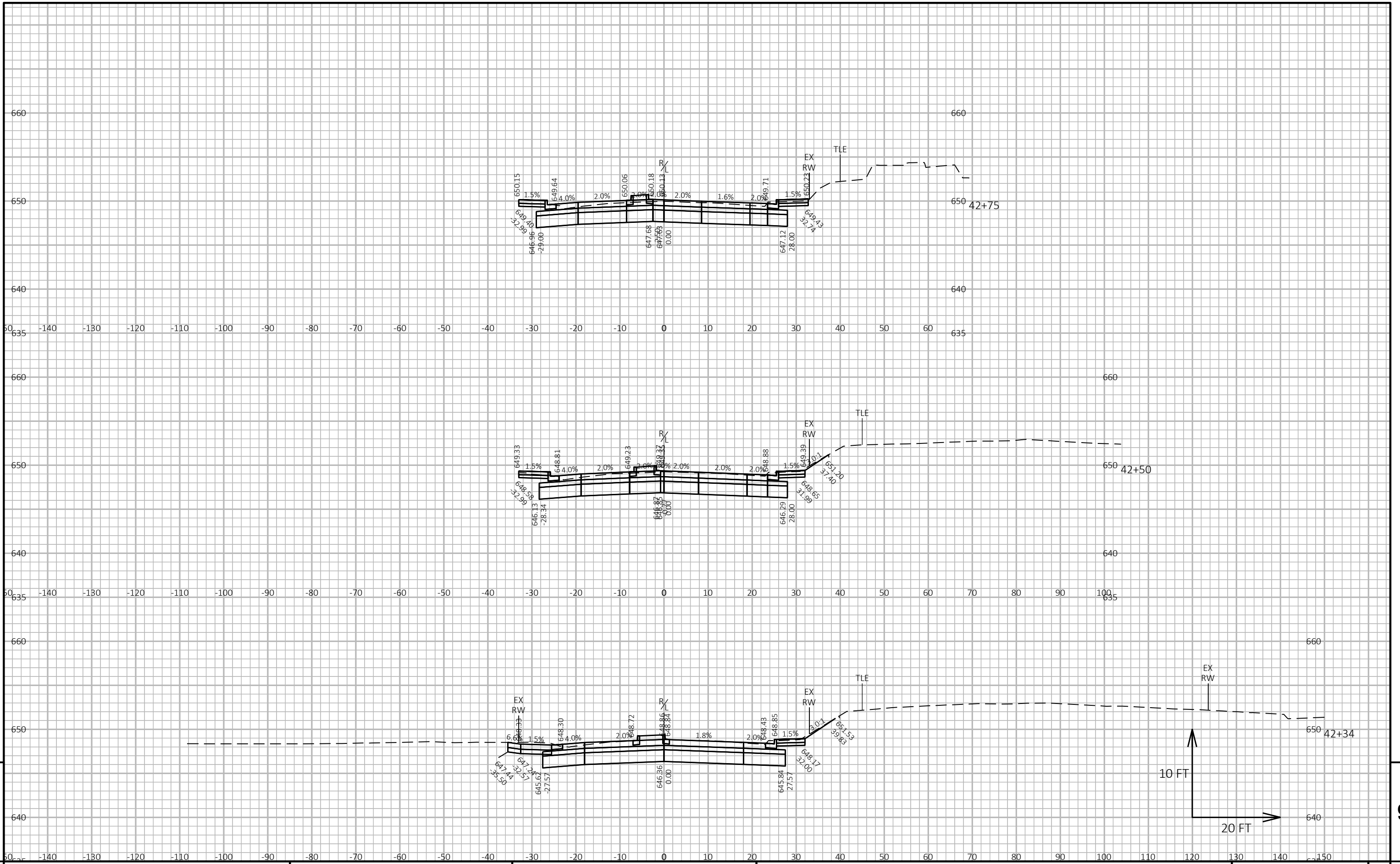

9

9

PROJECT NO: 2230-07-73 HWY: W. GREENFIELD AVENUE COUNTY: MILWAUKEE CROSS SECTIONS - W GREENFIELD AVENUE SHEET E

FILE NAME : X:\ML\2021\20210099\DESIGN\TRANSPORTATION\SHEETSPLAN\090201_XS.DWG PLOT DATE : 7/19/2023 2:19 PM PLOT BY : BIEBERITZ, BEN PLOT NAME : PLOT SCALE : 1 IN:20 FT HORZ. / 1 IN:10 FT VERT. WISDOT/CADD SHEET 49

LAYOUT NAME - 090228_xs

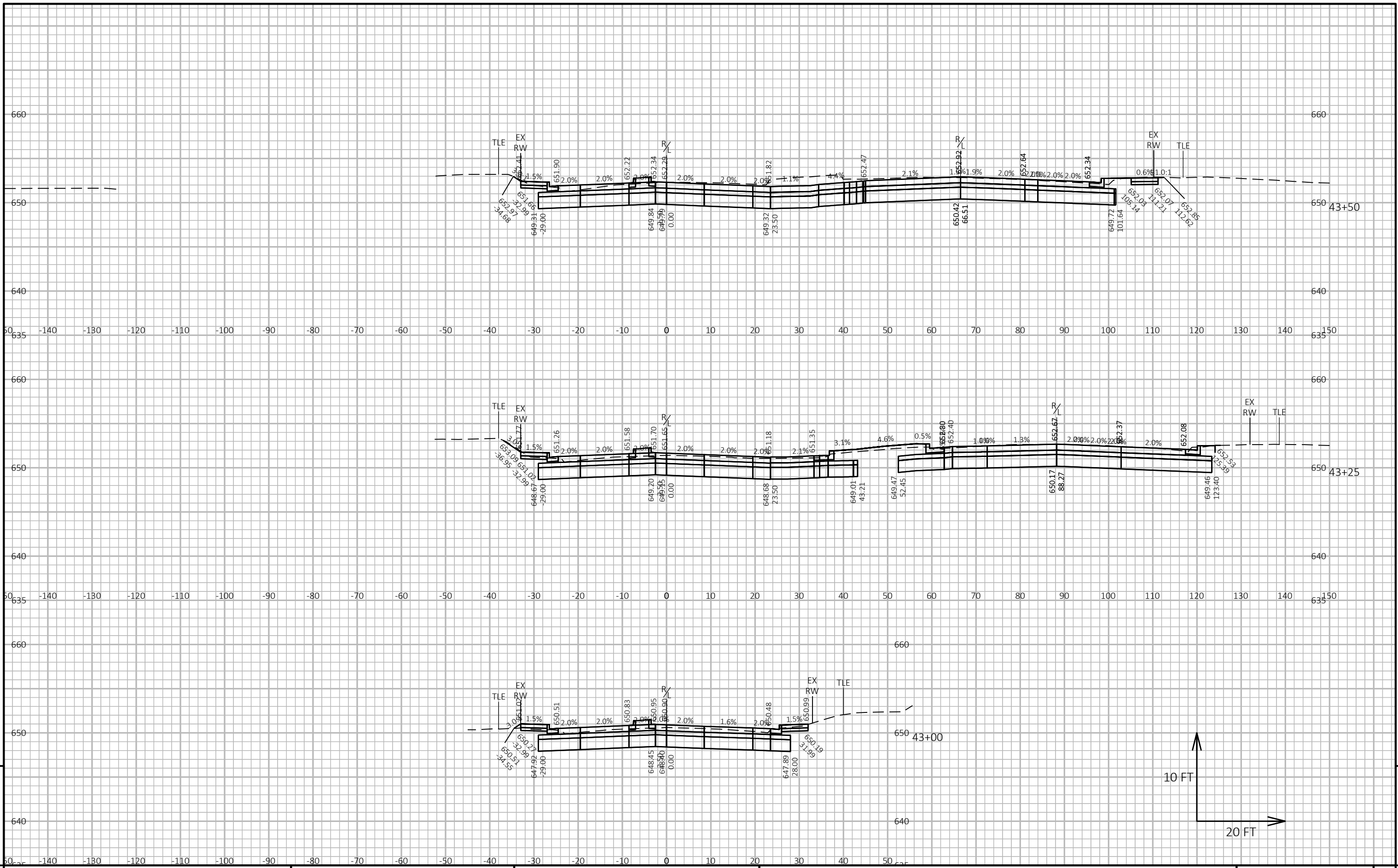

9

9

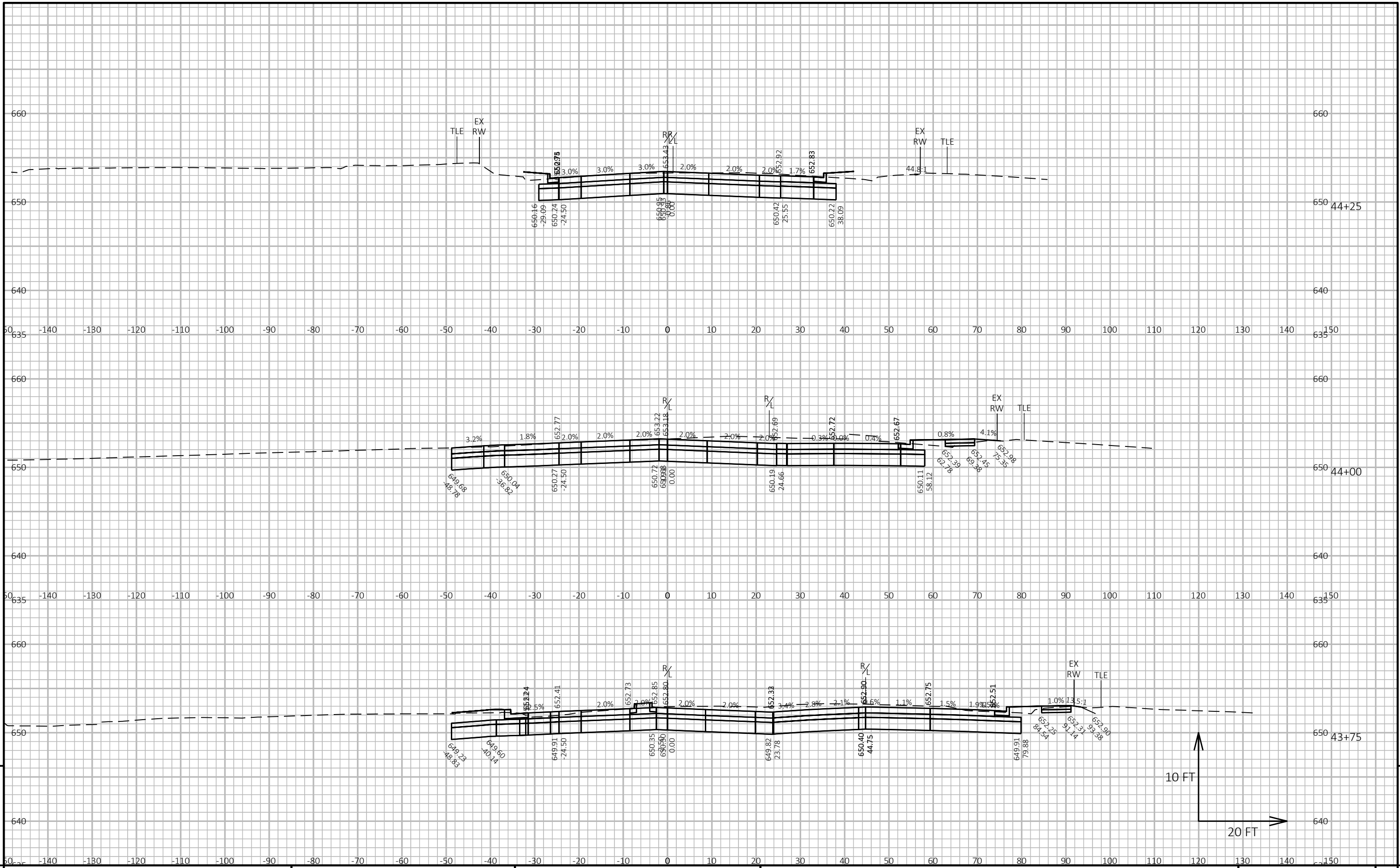

9

10 FT

20 FT

9

PROJECT NO: 2230-07-73 HWY: W. GREENFIELD AVENUE COUNTY: MILWAUKEE CROSS SECTIONS - W GREENFIELD AVENUE SHEET E

FILE NAME : X:\ML\2021\20210099\DESIGN\TRANSPORTATION\SHEETSPLAN\090201_XS.DWG PLOT DATE : 7/19/2023 2:19 PM PLOT BY : BIEBERITZ, BEN PLOT NAME : PLOT SCALE : 1 IN:20 FT HORZ. / 1 IN:10 FT VERT. WISDOT/CADD SHEET 49

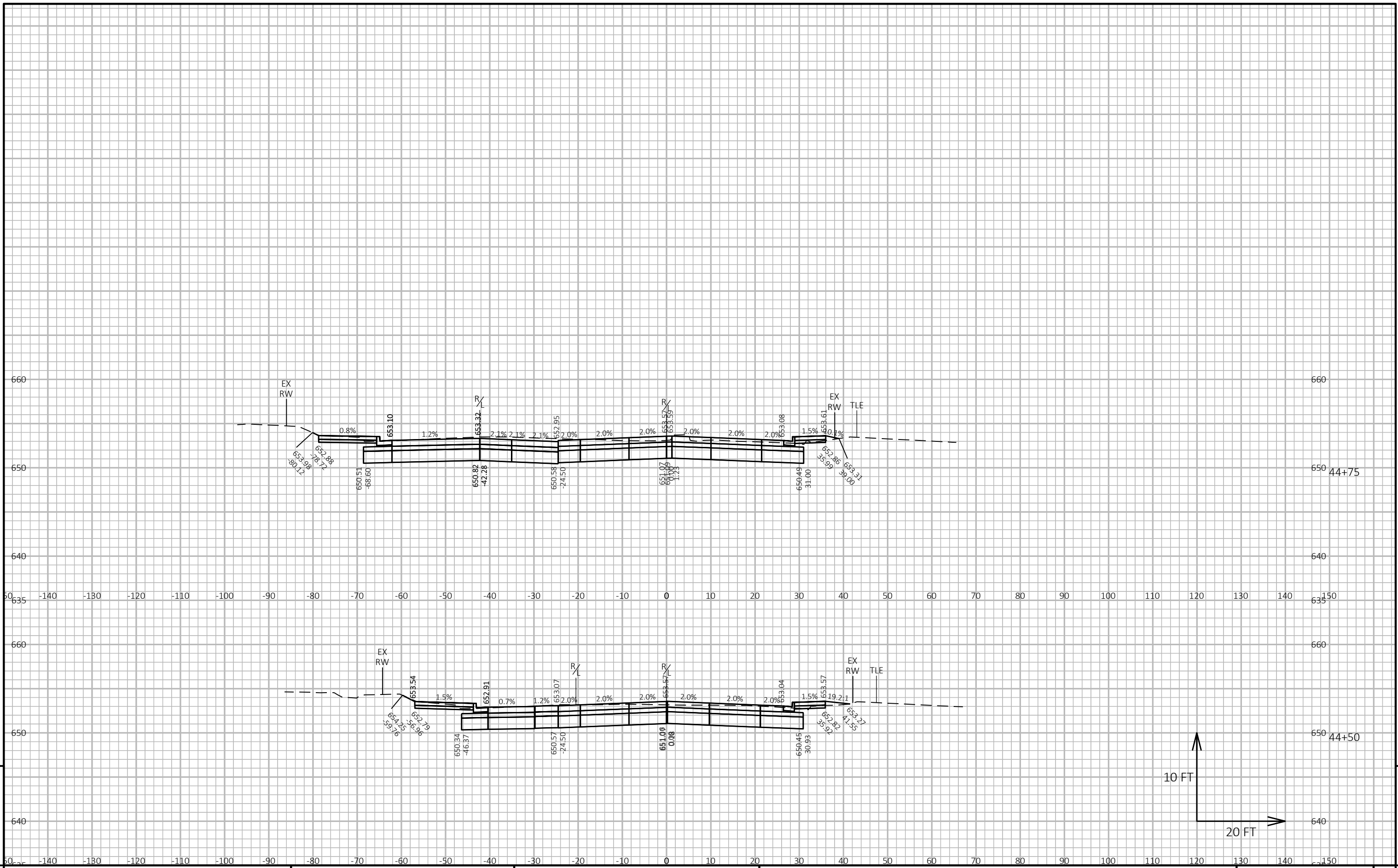

9

9

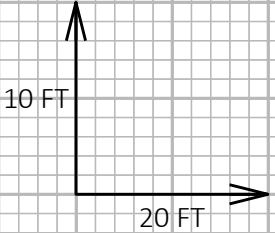

PROJECT NO: 2230-07-73 HWY: W. GREENFIELD AVENUE COUNTY: MILWAUKEE CROSS SECTIONS - W GREENFIELD AVENUE SHEET E

FILE NAME : X:\ML\2021\20210099\DESIGN\TRANSPORTATION\SHEETSPLAN\090201_XS.DWG PLOT DATE : 7/19/2023 2:19 PM PLOT BY : BIEBERITZ, BEN PLOT NAME : PLOT SCALE : 1 IN:20 FT HORZ. / 1 IN:10 FT VERT. WISDOT/CADD SHEET 49

LAYOUT NAME - 090231_xs

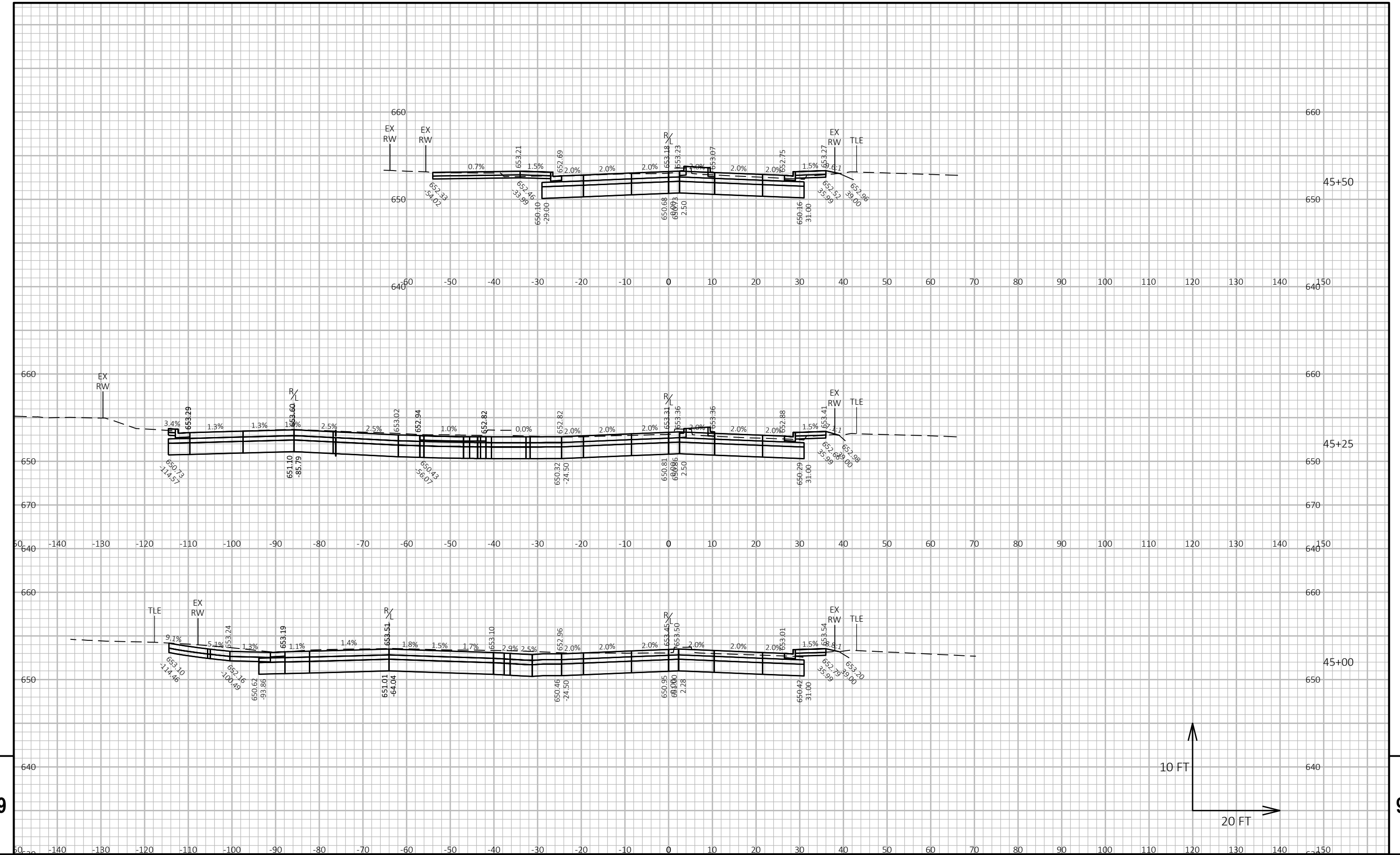

9

9

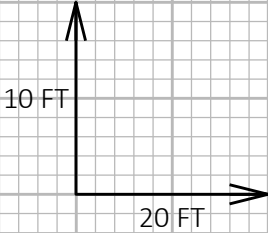

PROJECT NO: 2230-07-73

HWY: W. GREENFIELD AVENUE

COUNTY: MILWAUKEE

CROSS SECTIONS - W GREENFIELD AVENUE

SHEET

E

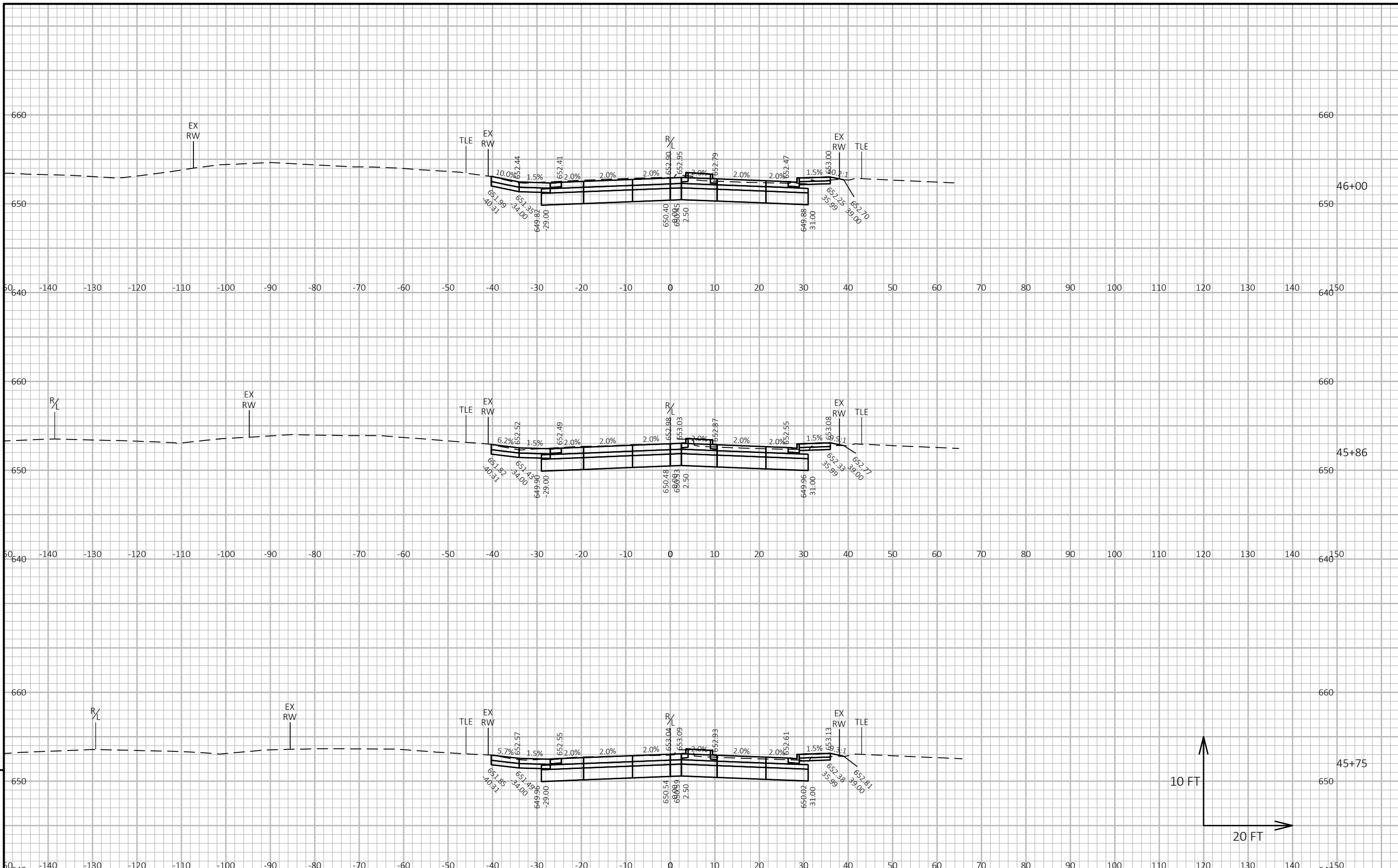

9

9

PROJECT NO: 2230-07-73 HWY: W. GREENFIELD AVENUE COUNTY: MILWAUKEE CROSS SECTIONS - W GREENFIELD AVENUE SHEET E

FILE NAME : X:\ML\2021\20210099\DESIGN\TRANSPORTATION\SHEETSPLAN\090202_XS.DWG PLOT DATE : 7/19/2023 2:22 PM PLOT BY : BIEBERITZ, BEN PLOT NAME : PLOT SCALE : 1 IN:20 FT HORZ. / 1 IN:10 FT VERT. WISDOT/CADD SHEET 49

LAYOUT NAME - 090225_xs

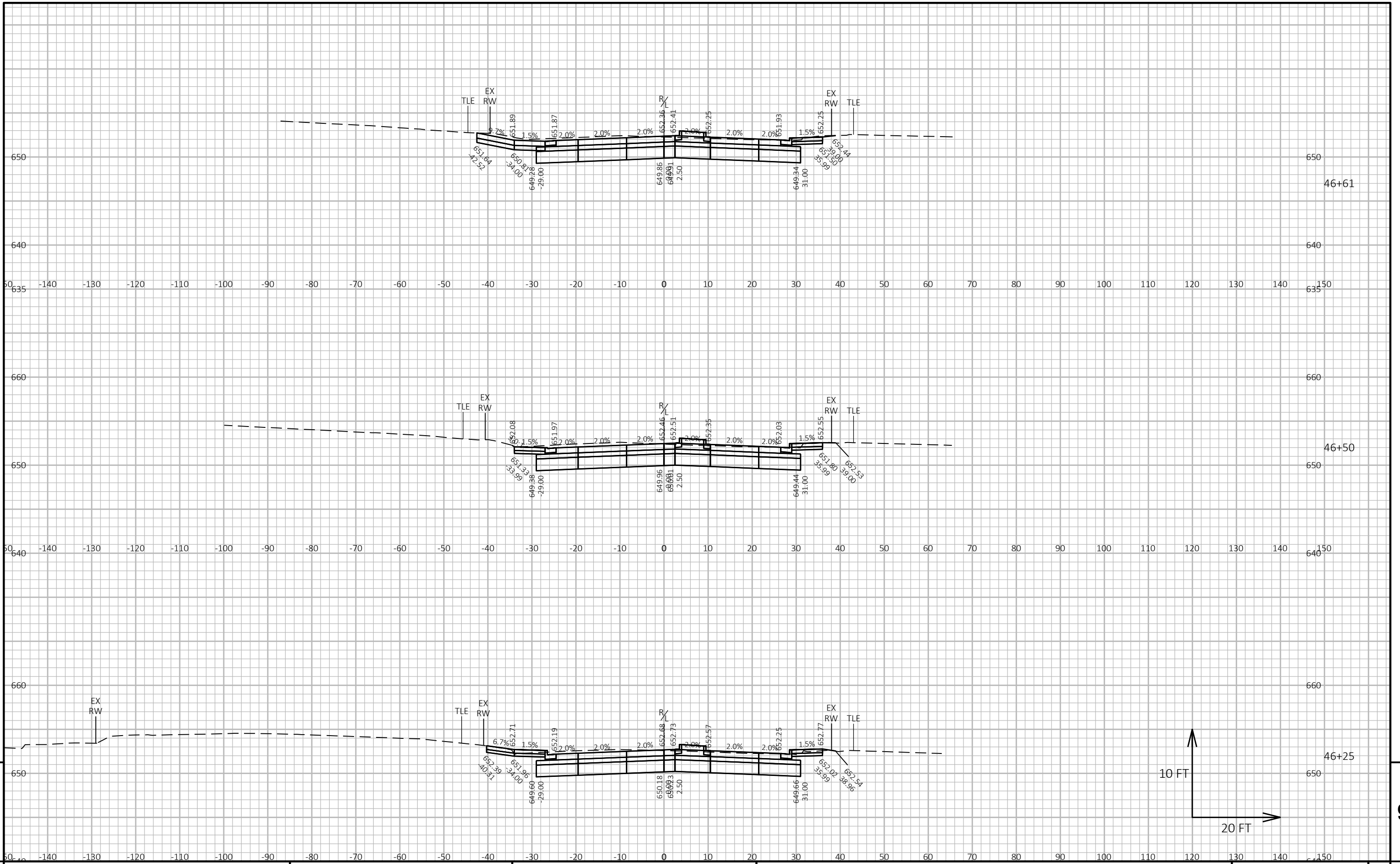

9

9

PROJECT NO: 2230-07-73 HWY: W. GREENFIELD AVENUE COUNTY: MILWAUKEE CROSS SECTIONS - W GREENFIELD AVENUE SHEET E

FILE NAME : X:\ML\2021\20210099\DESIGN\TRANSPORTATION\SHEETSPLAN\090202_XS.DWG PLOT DATE : 7/19/2023 2:22 PM PLOT BY : BIEBERITZ, BEN PLOT NAME : PLOT SCALE : 1 IN:20 FT HORZ. / 1 IN:10 FT VERT. WISDOT/CADD SHEET 49

LAYOUT NAME - 090226_xs

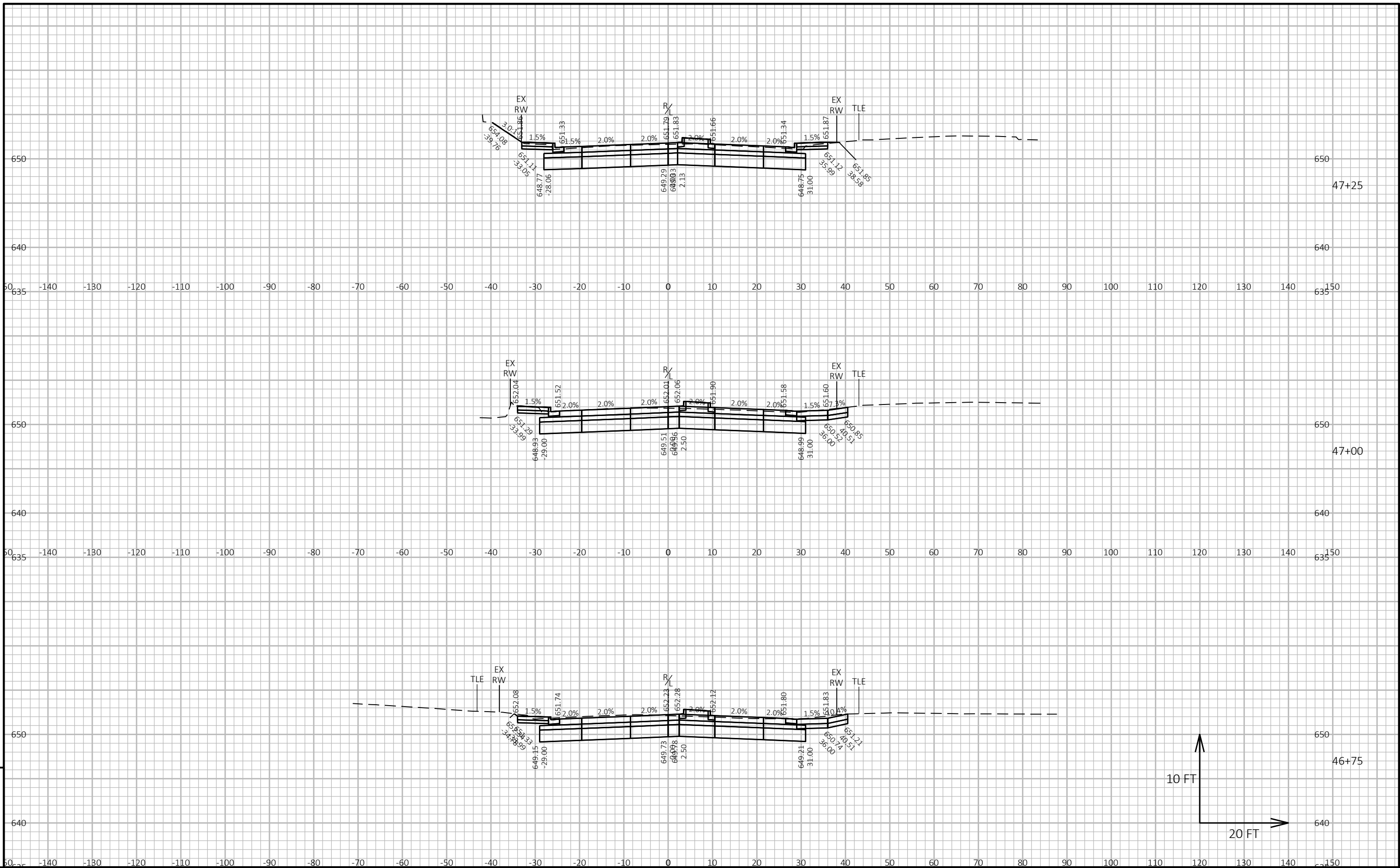

9

9

PROJECT NO: 2230-07-73 HWY: W. GREENFIELD AVENUE COUNTY: MILWAUKEE CROSS SECTIONS - W GREENFIELD AVENUE SHEET E

FILE NAME : X:\ML\2021\20210099\DESIGN\TRANSPORTATION\SHEETSPLAN\090202_XS.DWG PLOT DATE : 7/19/2023 2:22 PM PLOT BY : BIEBERITZ, BEN PLOT NAME : PLOT SCALE : 1 IN:20 FT HORZ. / 1 IN:10 FT VERT. WISDOT/CADD SHEET 49

LAYOUT NAME - 090227_xs

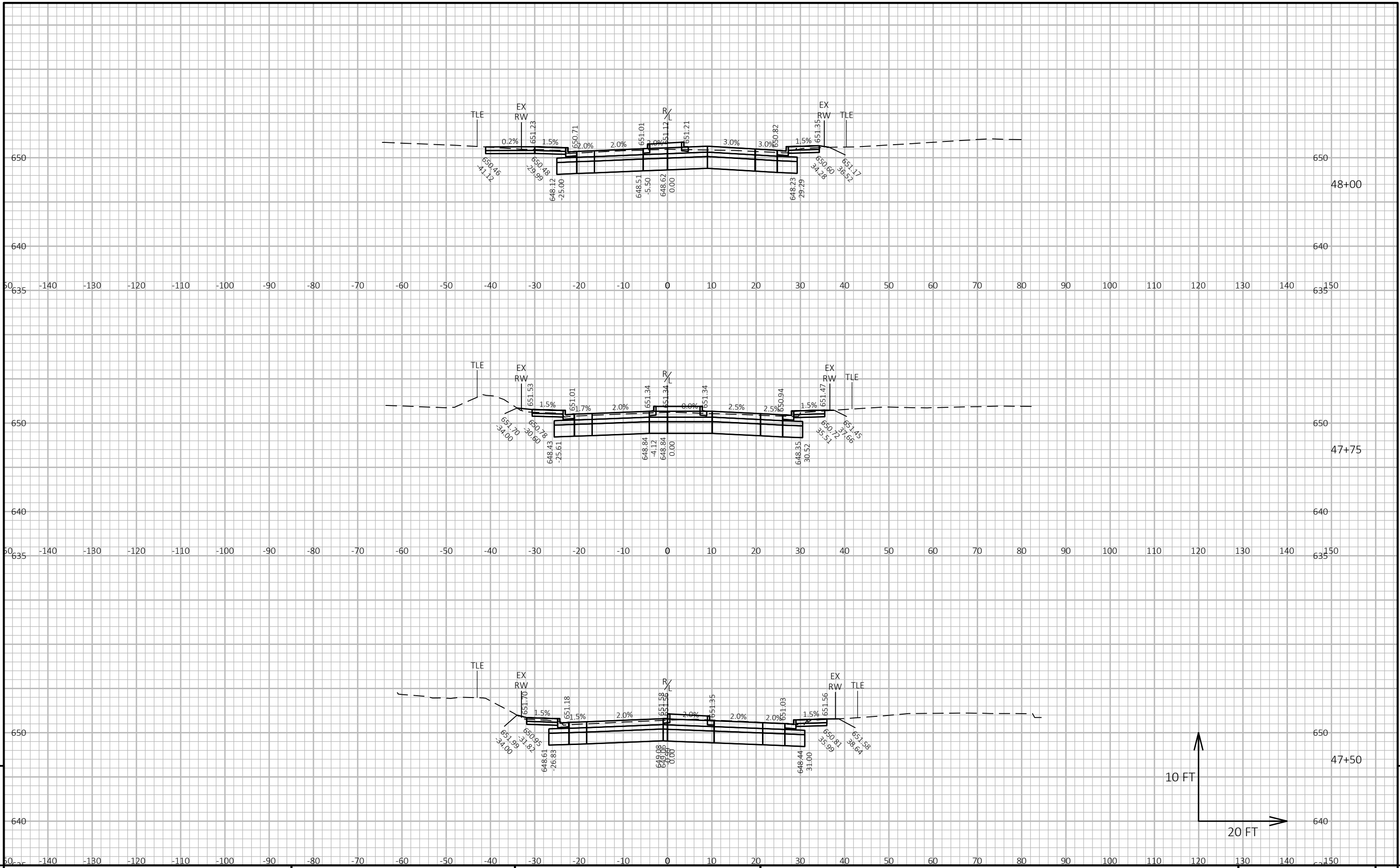

9

9

PROJECT NO: 2230-07-73 HWY: W. GREENFIELD AVENUE COUNTY: MILWAUKEE CROSS SECTIONS - W GREENFIELD AVENUE SHEET E

FILE NAME : X:\ML\2021\20210099\DESIGN\TRANSPORTATION\SHEETSPLAN\090202_XS.DWG PLOT DATE : 7/19/2023 2:22 PM PLOT BY : BIEBERITZ, BEN PLOT NAME : PLOT SCALE : 1 IN:20 FT HORZ. / 1 IN:10 FT VERT. WISDOT/CADD SHEET 49

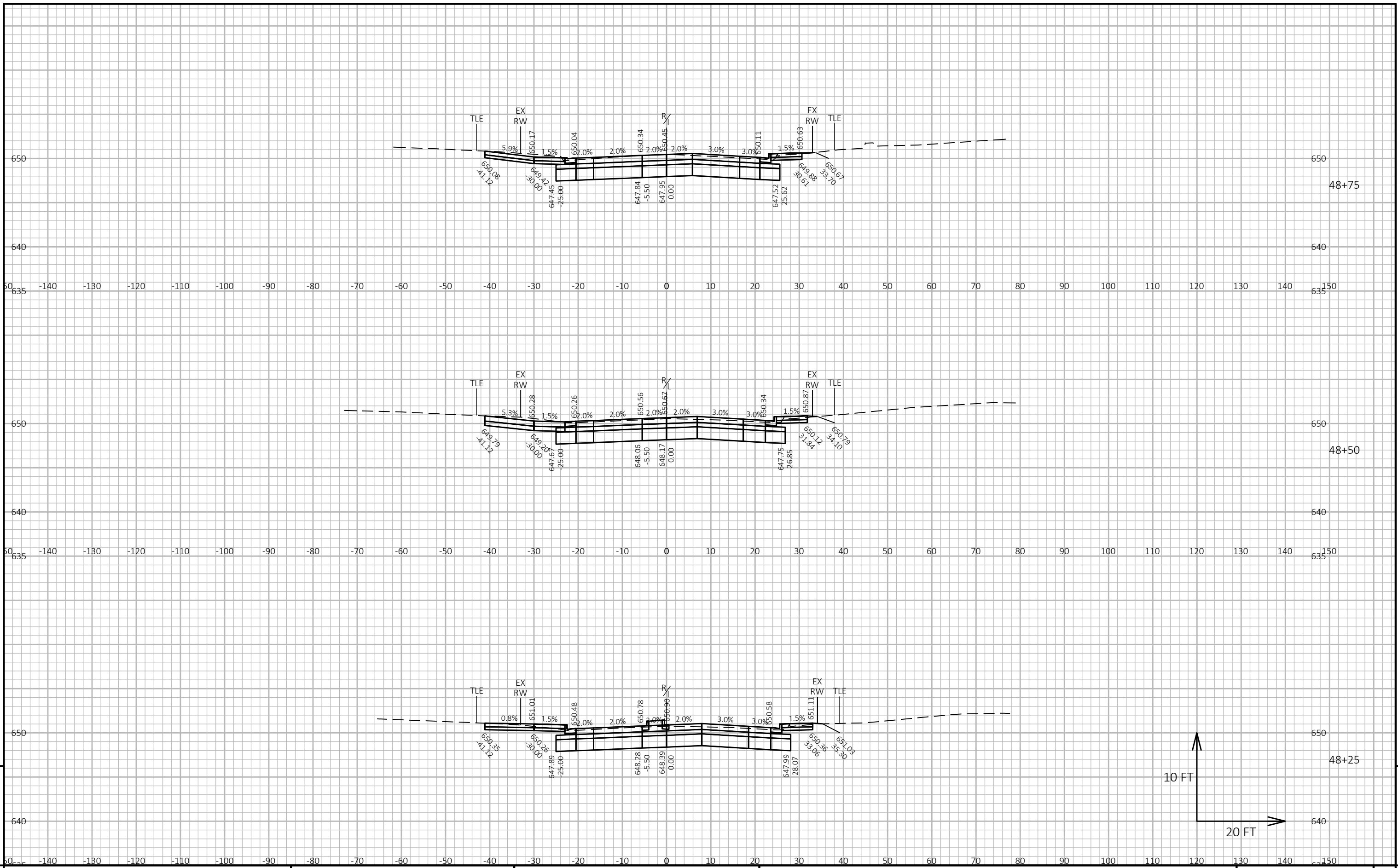

PROJECT NO: 2230-07-73 HWY: W. GREENFIELD AVENUE COUNTY: MILWAUKEE CROSS SECTIONS - W GREENFIELD AVENUE SHEET E

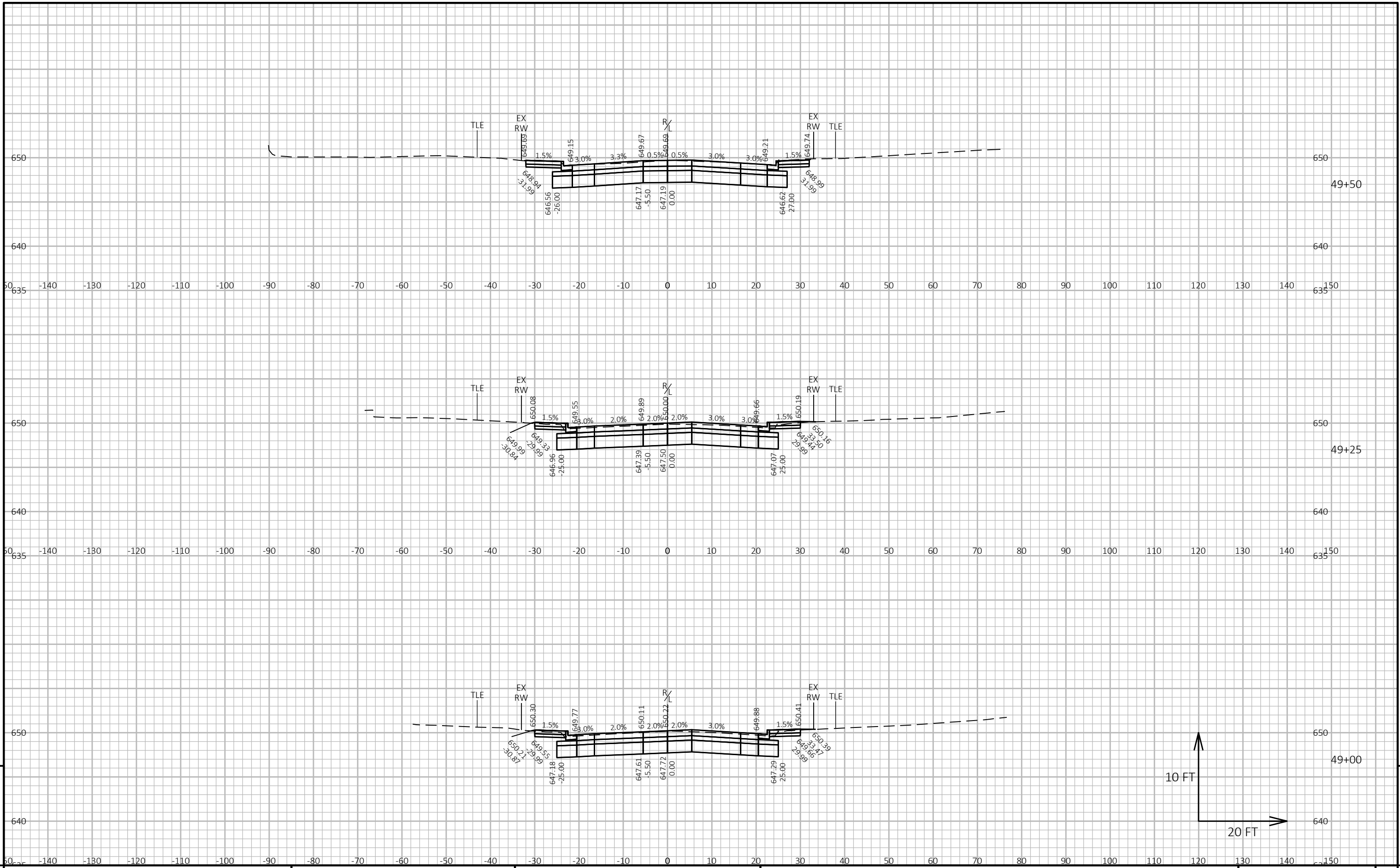

PROJECT NO: 2230-07-73 HWY: W. GREENFIELD AVENUE COUNTY: MILWAUKEE CROSS SECTIONS - W GREENFIELD AVENUE SHEET E

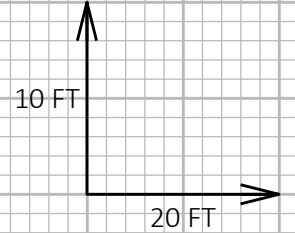
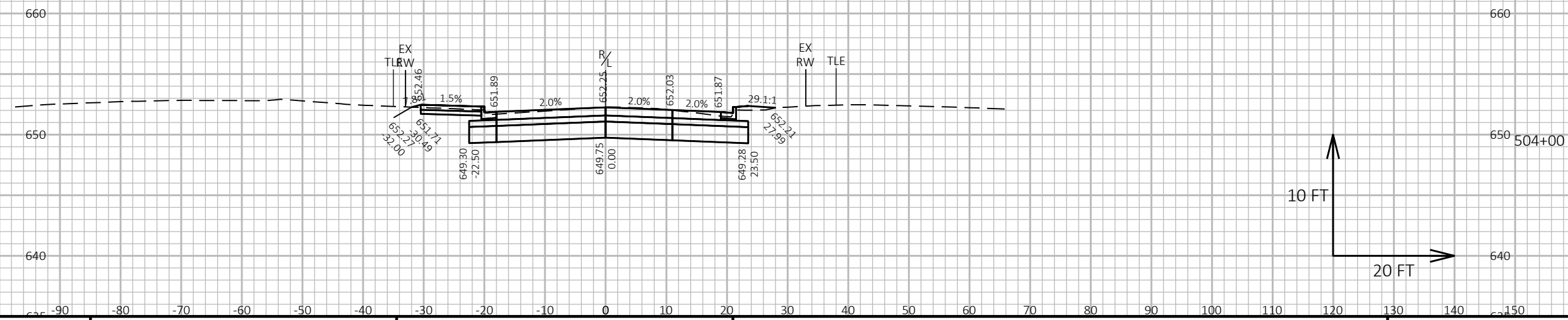
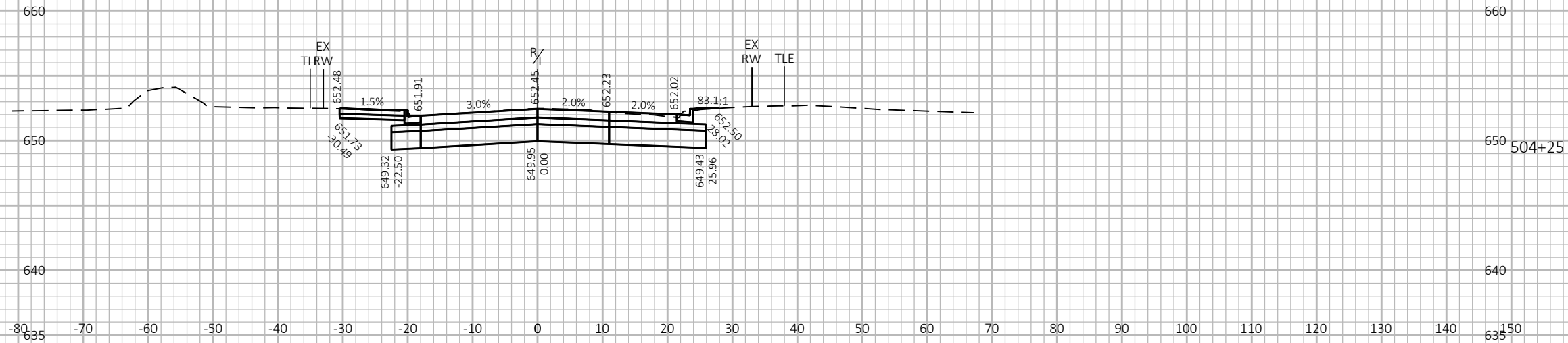
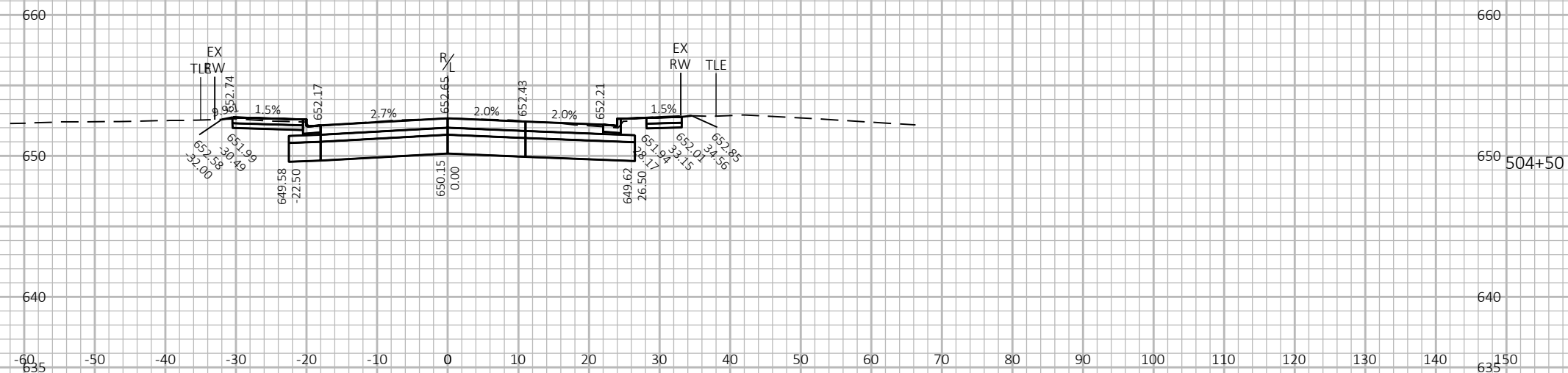

9

PROJECT NO: 2230-07-73 HWY: W. GREENFIELD AVENUE COUNTY: MILWAUKEE CROSS SECTIONS - W BELOIT ROAD SHEET E

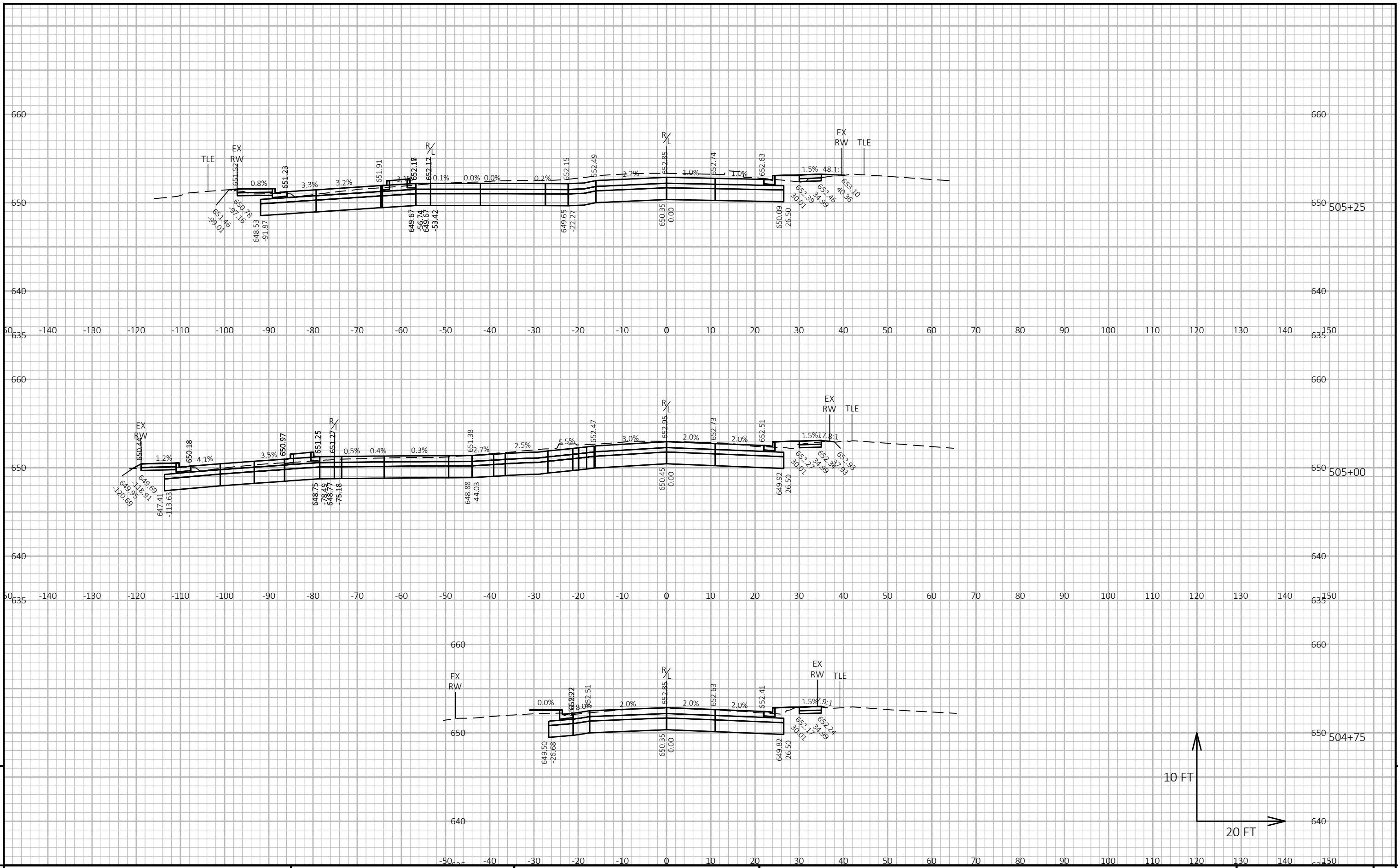

9

9

PROJECT NO: 2230-07-73 HWY: W. GREENFIELD AVENUE COUNTY: MILWAUKEE CROSS SECTIONS - W BELOIT ROAD SHEET E

FILE NAME : X:\ML\2021\20210099\DESIGN\TRANSPORTATION\SHEETSPLAN\090202_XS.DWG PLOT DATE : 7/19/2023 2:23 PM PLOT BY : BIEBERITZ, BEN PLOT NAME : PLOT SCALE : 1 IN:20 FT HORZ. / 1 IN:10 FT VERT. WISDOT/CADD SHEET 49

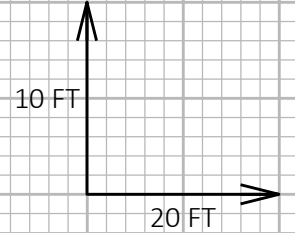

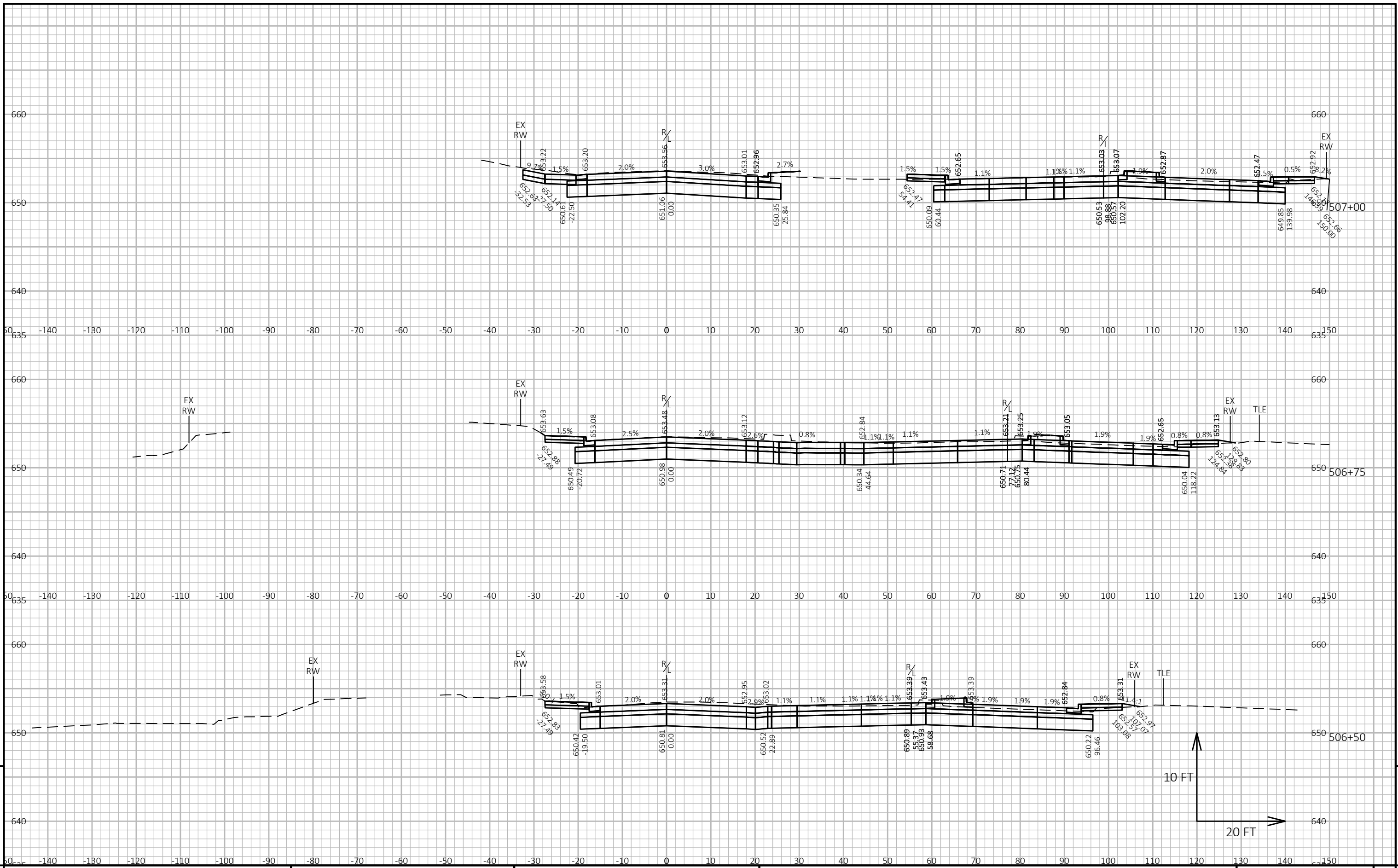

PROJECT NO: 2230-07-73 HWY: W. GREENFIELD AVENUE COUNTY: MILWAUKEE CROSS SECTIONS - W BELOIT ROAD SHEET 9

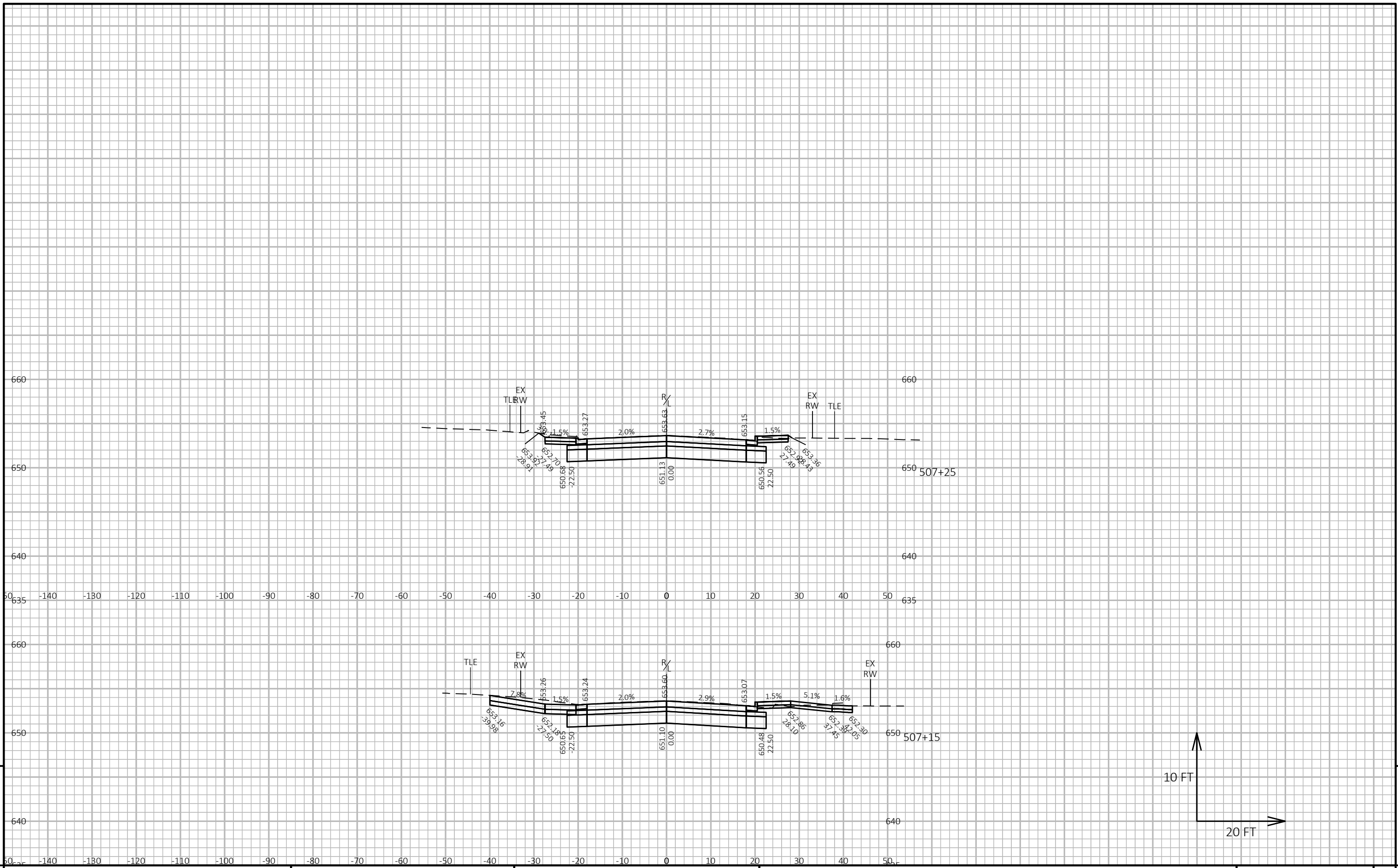

9

9

PROJECT NO: 2230-07-73 HWY: W. GREENFIELD AVENUE COUNTY: MILWAUKEE CROSS SECTIONS - W BELOIT ROAD SHEET E

FILE NAME: X:\ML\2021\20210099\DESIGN\TRANSPORTATION\SHEETSPLAN\090202_XS.DWG PLOT DATE: 7/19/2023 2:23 PM PLOT BY: BIEBERITZ, BEN PLOT NAME: PLOT SCALE: 1 IN:20 FT HORZ. / 1 IN:10 FT VERT. WISDOT/CADD SHEET 49

LAYOUT NAME - 090246_xs



Wisconsin Department of Transportation

Dedicated people creating transportation solutions through innovation and exceptional service.

<http://www.dot.wisconsin.gov>