

MAINLINE TYPICAL SECTIONS

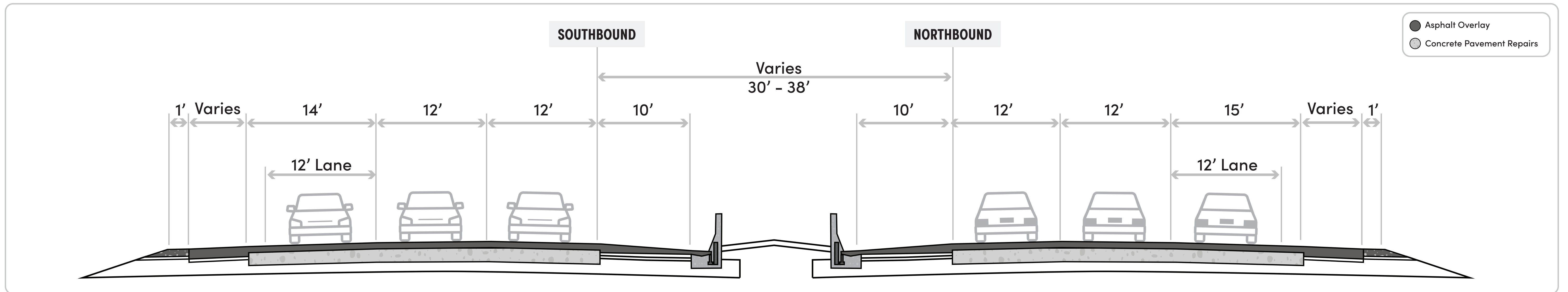

NORTHBOUND and SOUTHBOUND US 151

PROPOSED TYPICAL SECTIONS *LOOKING NORTH*



AMERICAN PARKWAY to MAIN STREET

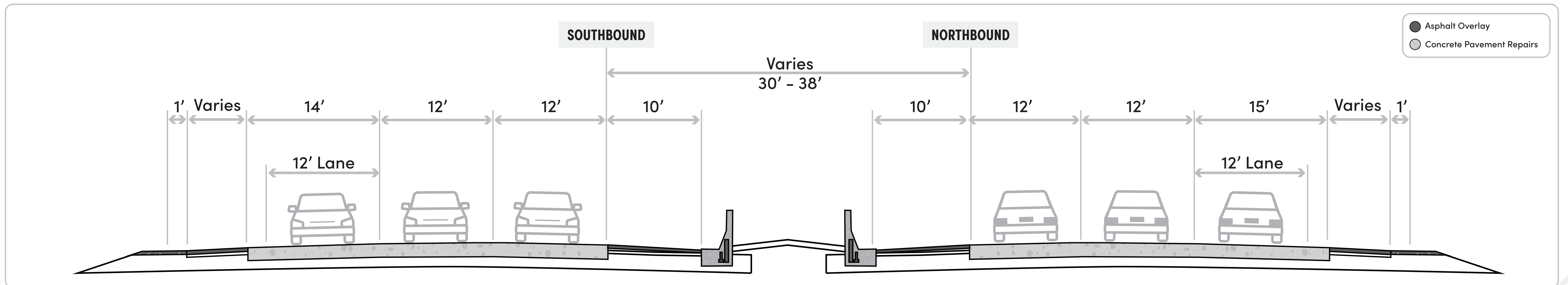

I-39/90/94 to AMERICAN PARKWAY

RAMP TYPICAL SECTIONS



SOUTHBOUND *and* NORTHBOUND US 151 RAMPS

PROPOSED TYPICAL SECTIONS *LOOKING NORTH*

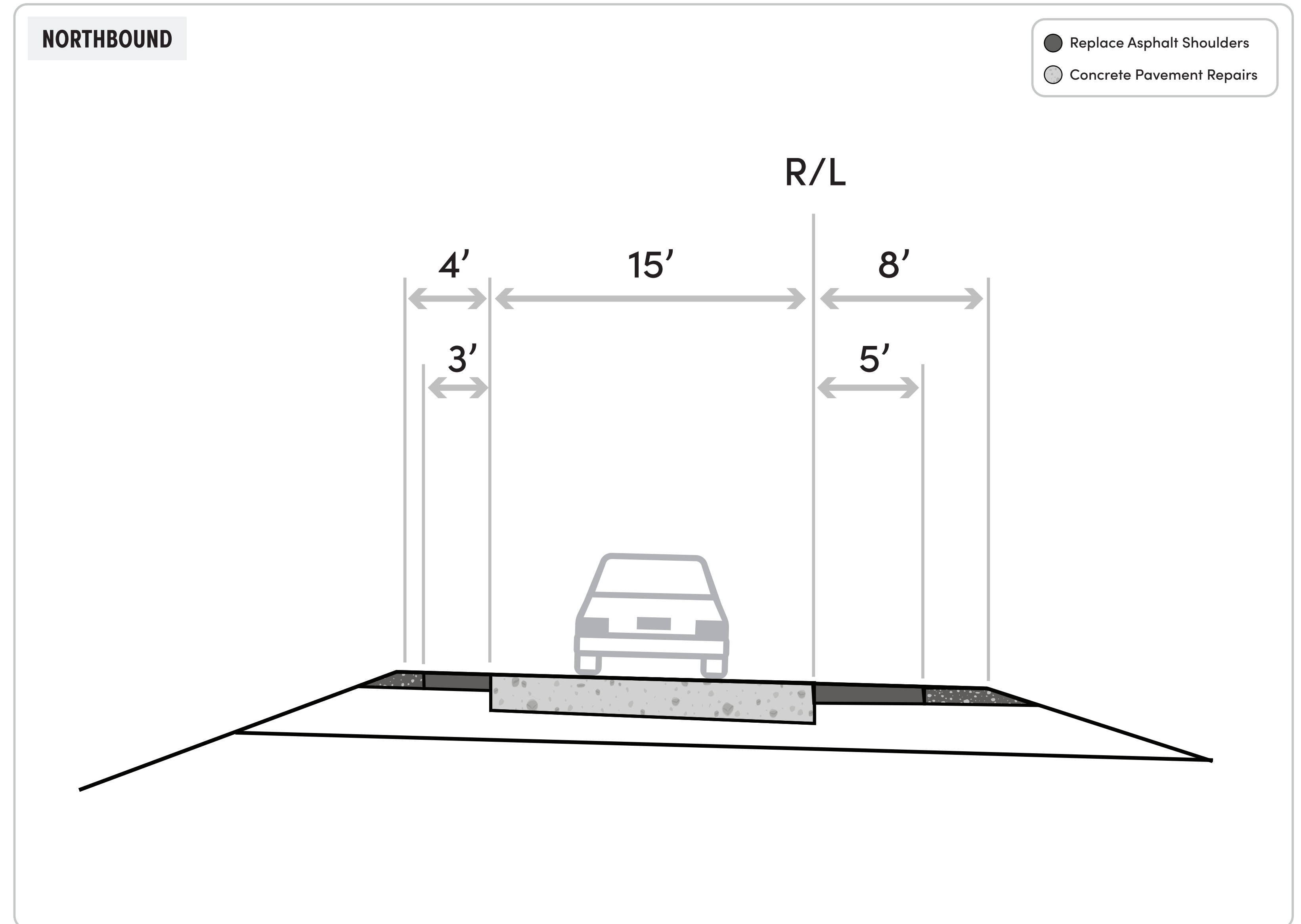
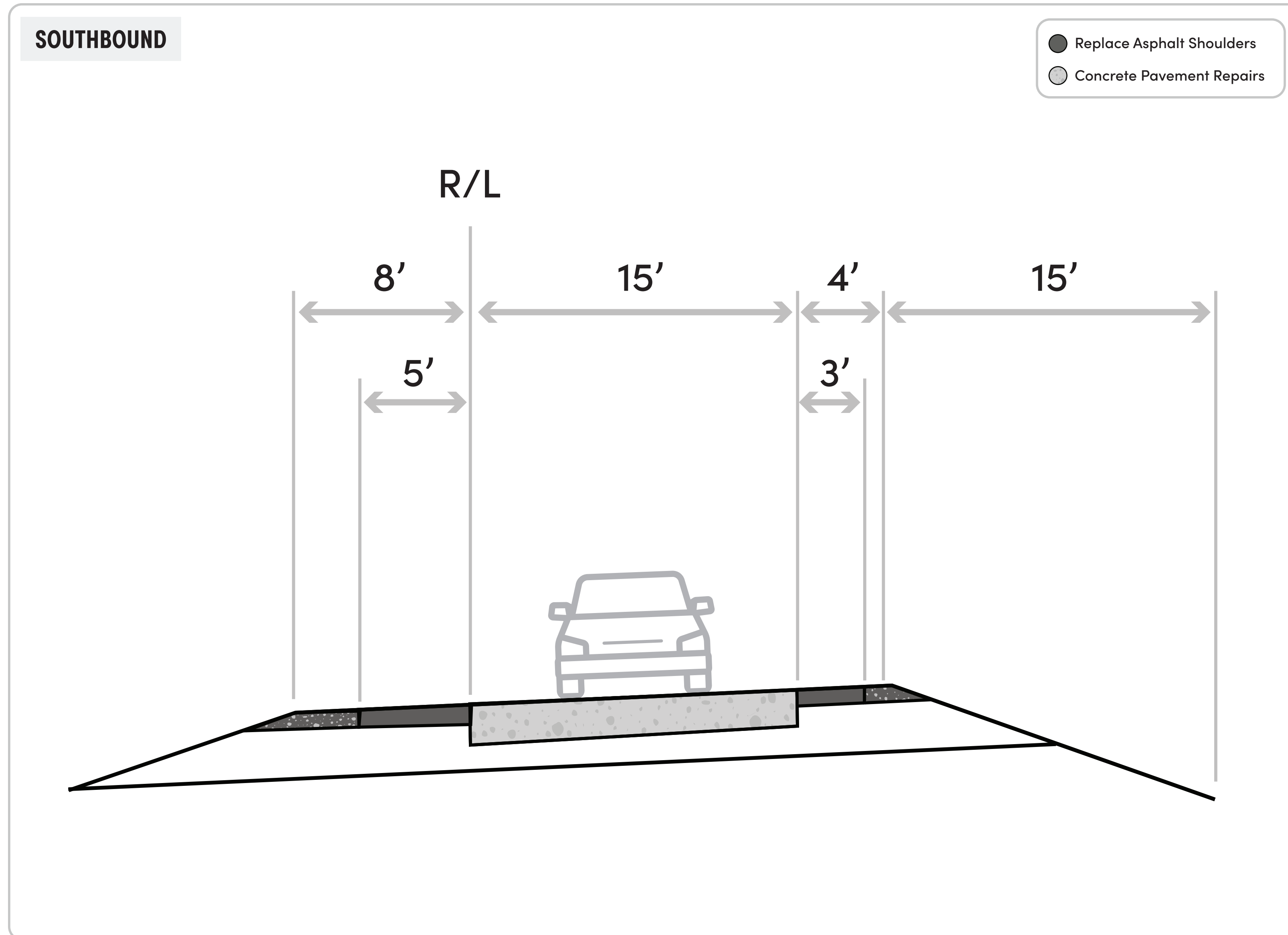

RAMP WORK *at* AMERICAN PARKWAY INTERCHANGE *and* REINER ROAD/GRAND AVENUE INTERCHANGE

PROJECT AREA MAP



MADISON to SUN PRAIRIE

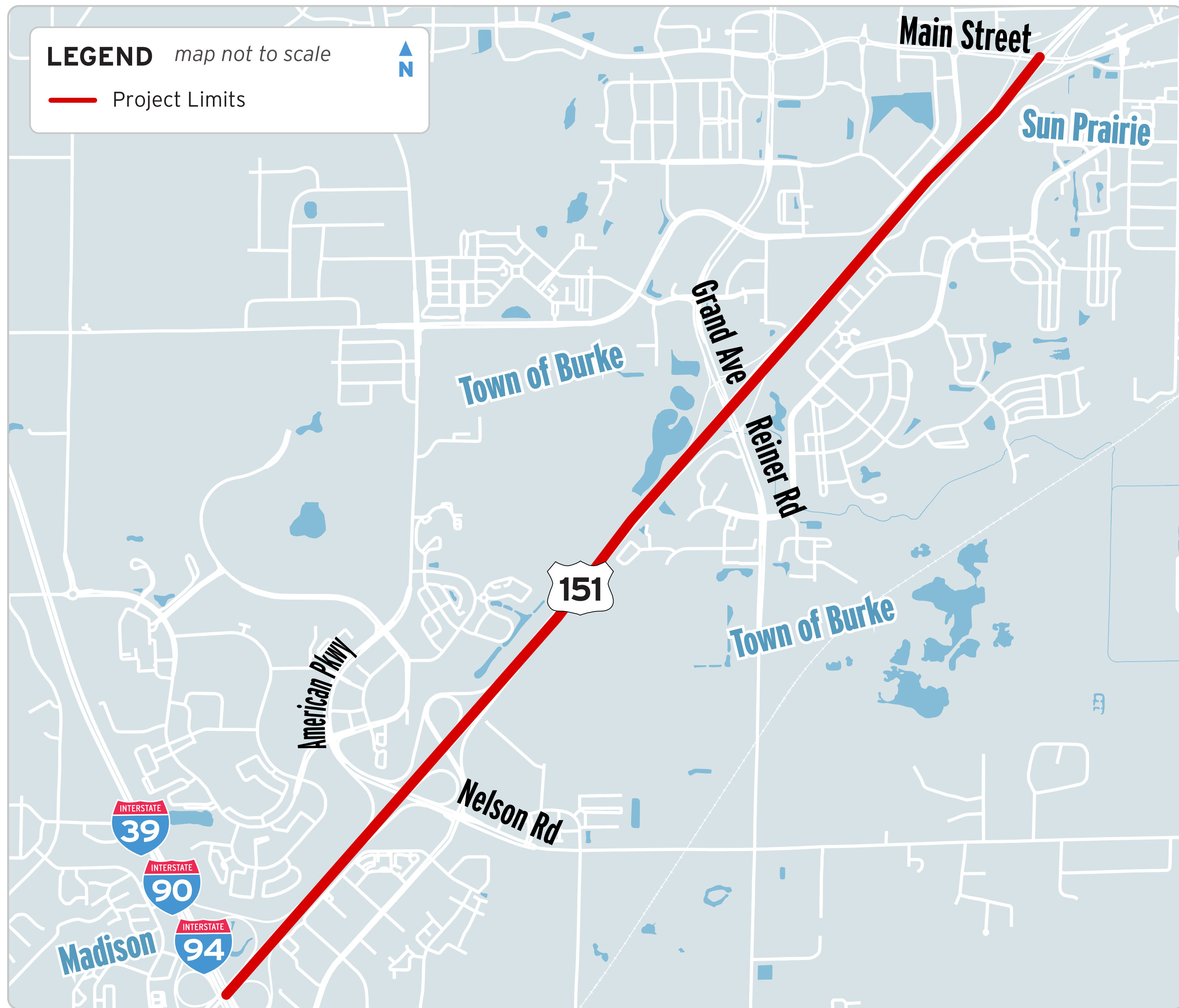

PROJECT OVERVIEW

The purpose of this project is to extend the life of the pavement along US 151 between I-39/90/94 and Main Street. This project will provide a safer ride for motorists and improve drainage to prevent erosion. Improvements include:

- Asphalt overlay between American Parkway and Main Street
- Patch existing concrete
- Partial beam guard replacement
- Improve sidewalk curb ramps at interchange terminals
- Clean drainage pipes
- 2029 construction anticipated

LEARN MORE



LEARN MORE ABOUT THE US 151 PROJECT by SCANNING QR CODE

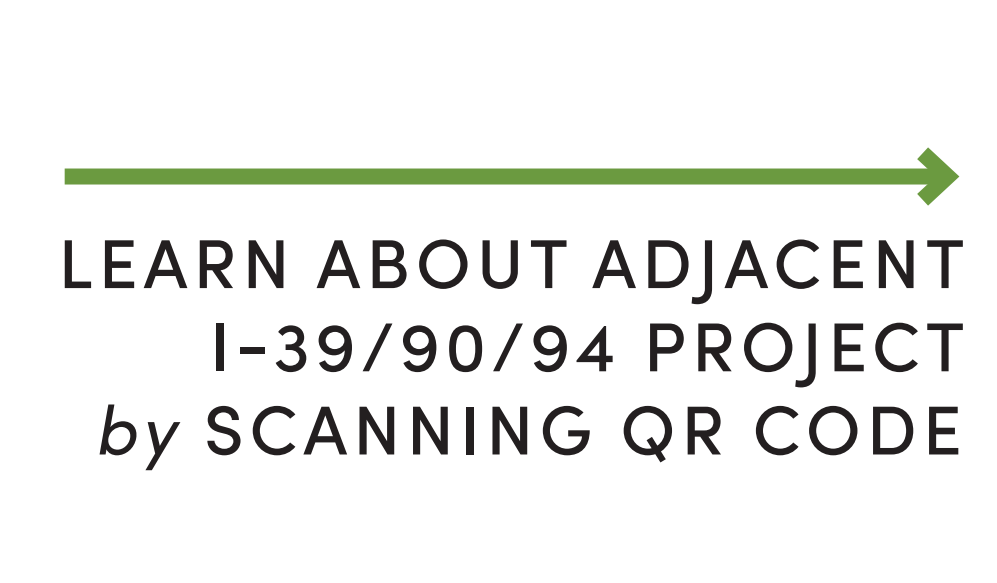

LEARN ABOUT ADJACENT I-39/90/94 PROJECT by SCANNING QR CODE