



MAXIMUM WEIGHT LIMITATIONS SUMMARY

On Class "A" Highways

Wisconsin Department of Transportation (WisDOT)
SP4075 7/2024 Wis. Stat. § 348.15(1)(b)

General Maximum Weight Restrictions:

Although there is the possibility of increased weight on a particular wheel or axle or group of axles due to practical operating problems, including, but not limited to, accumulation of snow, ice, mud or dirt, the use of tire chains or minor shifting of load, the following maximum weights include absolutely all weights allowable [348.15(4)]. Class "B" highway weight limitations are 60 per cent of class "A" highway weight limitations [348.16(2)].

Any one wheel or wheels supporting one end of an axle [348.15(3)(a)].....	11,000 Lbs.
* Truck Tractor Steering Axle [348.15(3)(b)].....	13,000 Lbs.
** Single Axle (See Note) [348.15(3)(b)].....	20,000 Lbs.
Maximum Gross Vehicle Weight of all Axles [348.15(3)(c)].....	80,000 Lbs.

* Truck tractor steering axle may exceed 13,000 lbs. if the manufacturer's rated capacity of the axle and the tires are sufficient to carry the weight, but not to exceed 20,000 lbs. [348.15(3)(b)].

** 21,000 lbs. in the case of a vehicle or combination of vehicles transporting exclusively milk from the point of production to the primary market and the return of dairy supplies and dairy products from such primary market to the farm (not applicable to the National System of Interstate and Defense Highways) [348.15(3)(bg)].

** 21,500 lbs. in the case of a vehicle or combination of vehicles transporting exclusively peeled or unpeeled forest products cut crosswise or exclusively scrap metal (not applicable to the National System of Interstate and Defense Highways) [348.15(3)(br)].

Measuring:

The distances between the foremost and rearmost of a group of axles shall be measured between axle centers to the nearest even foot, and when a fraction is exactly one-half foot, the nearest larger whole number shall be used [348.15(5m)].

Note: "Axle" includes all wheels of a vehicle imposing weight on the highway, the centers of which are included between 2 parallel transverse vertical planes less than 42 inches apart, extending across the full width of vehicle and load. Therefore, two axles less than 42 inches apart are considered to be one axle and can carry no more than a single axle [348.01(2)(a)].

"Tandem axle" means any 2 or more consecutive axles whose centers are 42 or more inches apart and which are individually attached to or articulated from, or both, a common attachment to the vehicle including a connecting mechanism designed to equalize the load between axles [348.01(2)(c)].

Any axle of a vehicle or combination of vehicles which does not impose on the highway at least 8% of the gross weight of the vehicle or combination of vehicles may not be counted as an axle [348.15(8)].

Request form SP4370 when hauling under the provisions of 348.15(3)(br), exclusively peeled or unpeeled forest products cut crosswise OR exclusively scrap metal.

Request form SP4415 for the motor vehicle size regulation summary.

Request form SP4416 when hauling under permits issued pursuant to 348.27(9m)(a)1, raw forest and agricultural products.

Request form SP4417 when hauling under the provisions of 348.15(3)(bg), transporting exclusively milk from point of production to primary market and return of dairy supplies and dairy products from such primary market to the farm.

Permits Issued by the WisDOT OSOW Permit Unit:

Most permits for oversize/overweight (OSOW) vehicles are issued by the maintenance authority for the class of roadway on which the OSOW vehicle proposes to travel. With some exceptions, permits for operation on State, U.S. and Interstate highways are issued by the OSOW Permit Unit of the WisDOT Division of Transportation System Development.

Applications may be submitted in several ways:

- Online through the secured web site portal located at: <https://wi.gotpermits.com/>. For information, call: (608) 266-7320 or email at osow@dot.wi.gov. Once you are enrolled, this application is available to you 24/7. Most permits are automatically analyzed and approved.
- By overnight mail to: WisDOT OSOW Permits, 4822 Madison Yards Way, Madison, WI 53705.
- By mail to: WisDOT OSOW Permits, PO Box 7980, Madison, WI 53707.

MAXIMUM WEIGHT LIMITATIONS CHART

Vehicle Not In Combination

Column **A** Distance in Feet between foremost and rearmost axles of a group
 Column **B** **2** consecutive axles: of a 2-axle vehicle;
 OR of any vehicle having a total of 3 or more axles
 Column **C** **3** consecutive axles: of a 3-axle vehicle;
 OR of any vehicle having a total of 4 or more axles
 Column **D** **4** consecutive axles: of a 4-axle vehicle;
 OR of any vehicle having a total of 5 or more axles

Column **E** **5** consecutive axles: of a 5-axle vehicle;
 OR of any vehicle having a total of 6 or more axles
 Column **F** **6** consecutive axles of any vehicle having a total
 of 6 or more axles
 Column **G** **7** consecutive axles: of a 7-axle vehicle;
 OR of any vehicle having a total of 7 or more axles
 Column **H** **8** consecutive axles: of an 8-axle vehicle;
 OR of any vehicle having a total of 8 or more axles

Maximum Gross Weight in Pounds on a Group of Axles

A Feet	B 2 axles	C 3 axles	D 4 axles	E 5 axles	F 6 axles	G 7 axles	H 8 axles
4	34,000						
5	34,000						
6	34,000						
7	34,000	37,000					
7.5-8	35,000	38,500					
8.1-8.4	38,000	42,000					
9	39,000	43,000					
10	40,000*	43,500					
11		44,500					
12		45,000	55,500				
13		46,000	60,000				
14		46,500	60,500				
15		47,500	61,500				
16		48,000	62,000	64,200			
17		49,000	63,000	71,700			
18		49,500	63,500	72,200			
19		50,500	64,500	73,000			
20		51,500	65,000	73,000	73,000		
21		52,200	66,000	73,000	73,000	73,000	
22		52,900	66,500	73,000	73,000	73,000	
23		53,600	67,500	73,000	73,000	73,500	
24		54,300	68,500	73,000	73,000	74,000	
25		55,000	69,000	73,000	73,000	74,500	80,000
26		55,700	69,500	73,000	73,000	75,000	80,000
27		56,500	70,500	73,000	73,000	76,000	80,000
28		57,100	71,300	73,000	73,000	76,500	80,000
29		58,000	72,000	73,000	73,000	77,000	80,000
30		58,500	72,700	73,000	73,000	77,500	80,000
31		59,500	73,000	73,000	73,000	78,000	80,000
32		60,000**	73,000**	73,000**	73,000**	78,500	80,000**
33						79,500	
34						80,000***	

Instructions: Use this chart to determine maximum gross weight in pounds, on a group of axles for a **vehicle not in combination**, on Class "A" highways. See examples of vehicles below.

* Maximum at 10 or more feet between axles
 ** Maximum at 32 or more feet between axles
 *** Maximum at 34 or more feet between axles

20,000 pounds for a single axle

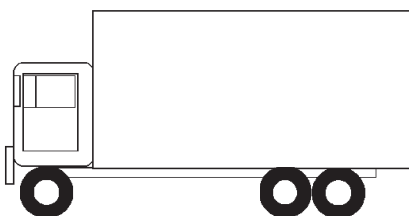
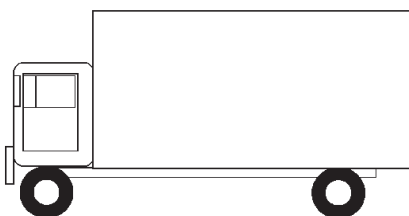

MAXIMUM WEIGHT LIMITATIONS CHART

Combination of Vehicles

Column **A** Distance in Feet between foremost and rearmost axles of a group
 Column **B** **2** consecutive axles of any combination of vehicles having a total of 3 or more axles
 Column **C** **3** consecutive axles of any combination of vehicles having a total of 4 or more axles
 Column **D** **4** consecutive axles of any combination of vehicles having a total of 5 or more axles

Column **E** **5** consecutive axles of any combination of vehicles having a total of 5 or more axles
 Column **F** **6** consecutive axles of any combination of vehicles having a total of 6 or more axles
 Column **G** **7** consecutive axles of any combination of vehicles having a total of 7 or more axles
 Column **H** **8** consecutive axles of any combination of vehicles having a total of 8 or more axles

Maximum Gross Weight in Pounds on a Group of Axles

A Feet	B 2 axles	C 3 axles	D 4 axles	E 5 axles	F 6 axles	G 7 axles	H 8 axles
4	34,000						
5	34,000						
6	34,000						
7	34,000	37,000					
7.5-8	35,000	38,500					
8.1-8.4	38,000	42,000					
9	39,000	43,000					
10	40,000*	43,500	48,500				
11		44,500	49,500				
12		45,000	50,000				
13		46,000	50,500	62,500			
14		46,500	51,500	62,500			
15		47,500	52,000	62,500			
16		48,000	52,500	62,500			
17		49,000	53,500	63,200	64,000		
18		49,500	54,100	64,400	65,000		
19		50,500	55,100	65,000	65,500		
20		51,500	56,000	65,700	66,000		
21		52,200	56,800	66,900	66,900	73,000	
22		52,900	57,600	67,700	67,700	73,000	
23		53,600	58,400	68,900	68,900	73,500	
24		54,300	59,200	70,000	70,000	74,000	
25		55,000	60,000	71,000	71,000	74,500	80,000
26		55,700	60,800	72,000	72,000	75,000	80,000
27		56,500	61,600	72,800	72,800	76,000	80,000
28		57,100	62,400	73,000	73,000	76,500	80,000
29		58,000	63,200	73,000	73,000	77,000	80,000
30		58,500	64,000	73,000	73,000	77,500	80,000
31		59,500	64,000	73,000	73,000	78,000	80,000
32		60,000**	64,000	73,000	73,000	78,500	80,000**
33			64,000	73,000	74,000	79,500	
34			64,500	73,000	74,500	80,000***	
35			65,500	73,000	75,000		
▪ 36			66,000	73,000	75,500		
▪ 37			66,500	73,000	76,000		
▪ 38			67,500	73,000	77,000		
39			68,000	73,000	77,500		
40			68,500	73,000	78,000		
41			69,500	73,500	78,500		
42			70,000	74,500	79,000		
43			70,500	75,000	80,000		
44			71,500	75,500	80,000		
45			72,000	76,000	80,000		
46			72,500	77,000	80,000		
47			73,500	77,500	80,000		
48			74,000	78,000	80,000		
49			74,500	78,500	80,000		
50			75,500	79,500	80,000		
51			76,000****	80,000****	80,000****		

Instructions: Use this chart to determine maximum gross weight in pounds, on a group of axles for a **combination of vehicles**, on Class "A" highways. See examples of combination of vehicles below.

- * Maximum at 10 or more feet between axles
- ** Maximum at 32 or more feet between axles
- *** Maximum at 34 or more feet between axles
- **** Maximum at 51 or more feet between axles

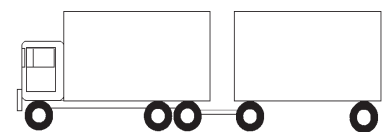
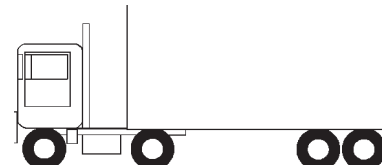

2 consecutive sets of tandem axles may impose on the highway a gross load of 34,000 pounds each if the overall distance between the first and last axles of such consecutive sets of tandem axles is 36 feet or more [348.15(3)(d)]

Examples of Maximum Weight that may be imposed on Class "A" Highways By axle, axle groups and gross weight of various vehicles

Measuring: [348.15(5m)]

The distances between the foremost and rearmost of a group of axles shall be measured between axle **CENTERS** to the nearest even foot, and when a fraction is exactly one-half foot, the nearest larger whole number shall be used. Example: 50 feet 5 inches = 50 feet; 50 feet 6 inches = 51 feet.

Example No. 1

1. Maximum weight that may be imposed by any axle of this vehicle is 20,000 lbs.
2. Maximum weight by the group of axles 1 and 2 when 10 feet or more apart is 40,000 lbs.

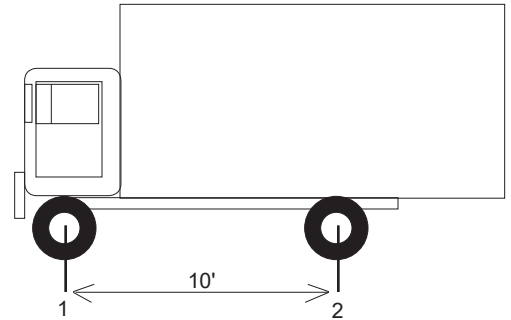

Example No. 2

1. Maximum weight that may be imposed by any axle of this vehicle is 20,000 lbs.
2. Maximum weight by the group of axles 1 and 2 with 10 feet spacing is 40,000 lbs.
3. Maximum weight by the group of axles 2 and 3 with 4 feet spacing is 34,000 lbs.
4. Maximum weight by the group of axles 1, 2 and 3 with a total spacing of 14 feet is 46,500 lbs.

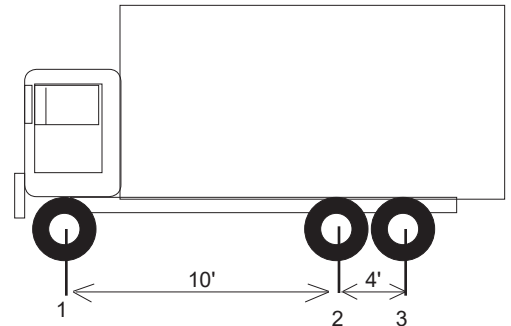

Example No. 3

1. Maximum weight that may be imposed by a truck tractor steering axle is 13,000 lbs. By any other axle, 20,000 lbs.
2. Maximum weight by the group of axles 1 and 2 is 33,000 lbs.
3. Maximum weight by the group of axles 2 and 3 with 28 feet spacing is 40,000 lbs.
4. Maximum weight by the group of axles 3 and 4 with 4 feet spacing is 34,000 lbs.
5. Maximum weight by the group of axles 1, 2 and 3 is 53,000 lbs.
6. Maximum weight by the group of axles 2, 3 and 4 is 54,000 lbs.

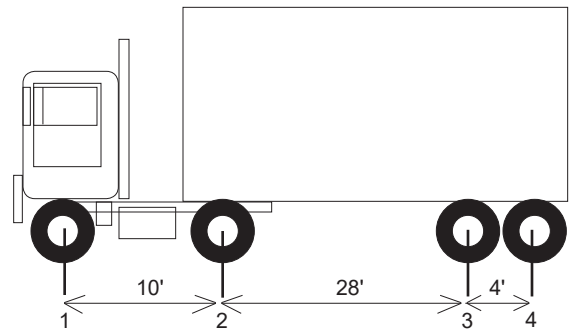

Example No. 4

1. Maximum weight that may be imposed by a truck tractor steering axle is 13,000 lbs. By any other axle, 20,000 lbs.
2. Maximum weight by the group of axles 1 and 2 is 33,000 lbs.
3. Maximum weight by the group of axles 2 and 3 with 4 feet spacing is 34,000 lbs.
4. Maximum weight by the group of axles 4 and 5 with 4 feet spacing is 34,000 lbs.
5. Since there is 36 feet between the group of axles 2, 3, 4 and 5 each consecutive set of tandem axles may impose 34,000 lbs. To attain 80,000 lbs., the remaining 12,000 lbs. may be imposed only by axle no. 1.
6. Maximum weight that this vehicle may impose is 80,000 lbs. See chart on previous page (axles 1 to 5 have 51 feet spacing).

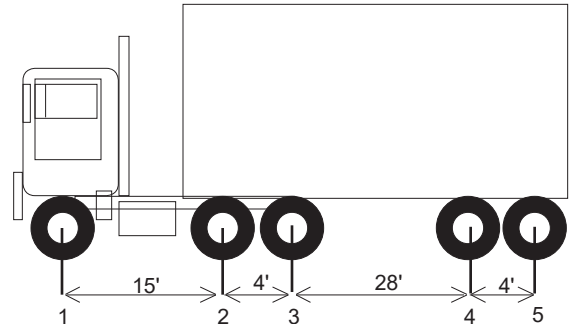

Example No. 5

1. Maximum weight that may be imposed by a truck tractor steering axle is 13,000 lbs. By any other axle, 20,000 lbs.
2. Maximum weight by the group of axles 1 and 2 is 33,000 lbs.
3. Maximum weight by the group of axles 2 and 3 with 22 feet spacing is 40,000 lbs.
4. Maximum weight by the group of axles 3 and 4 with 7 feet spacing is 34,000 lbs.
5. Maximum weight by the group of axles 4 and 5 is 40,000 lbs.
6. Maximum weight by the group of axles 2, 3 and 4 OR 3, 4, and 5 is 58,000 lbs.
7. Maximum weight by the group of axles 2, 3, 4 and 5 is 76,000 lbs.
8. Maximum weight is 80,000 lbs.

