



# US 53, Osseo – Eau Claire US 10 West to Old Town Hall Road

Trempealeau and Eau Claire counties

Project ID: 7995-00-01 (71)

**Spring 2024**

# Agenda

- Project Location
- Purpose and Need
- Proposed Improvements
- Proposed Design Overview
- Traffic Control
- Schedule
- Project Contacts
- Public Comment



# Project Location

- Trempealeau and Eau Claire counties
  - US 10 West to Old Town Hall Road

End project:  
Old Town Hall Road

Begin project:  
US 10 West

Project Length: 15.4 miles



# Purpose and Need

- Purpose of the project
  - Maintain a safe highway system for the traveling public
- Need for the project
  - Deteriorated pavement
  - Deteriorated culverts
  - Deteriorated structures
  - Outdated guardrail

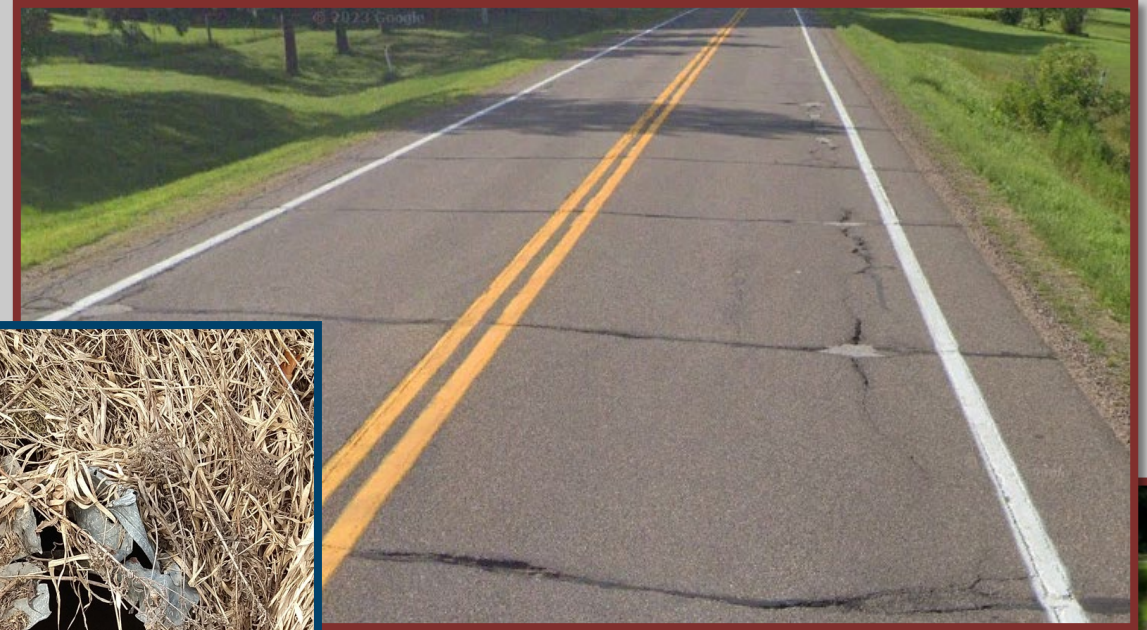

# Proposed Improvements

- US 53:

- Milling 2 inches of the existing pavement and adding a 2-inch asphaltic pavement overlay on the highway
- Replacing deteriorated culverts
- Cleaning ditches and culverts
- Replacing outdated guardrail
- Improving geometric safety elements at Hillview Road





# Proposed Design Overview

## Typical Proposed Section – US 53 US 10 West – County V

- Pavement

- 2-inch asphalt overlay

- Shoulders

- 3 feet paved, 1 foot gravel

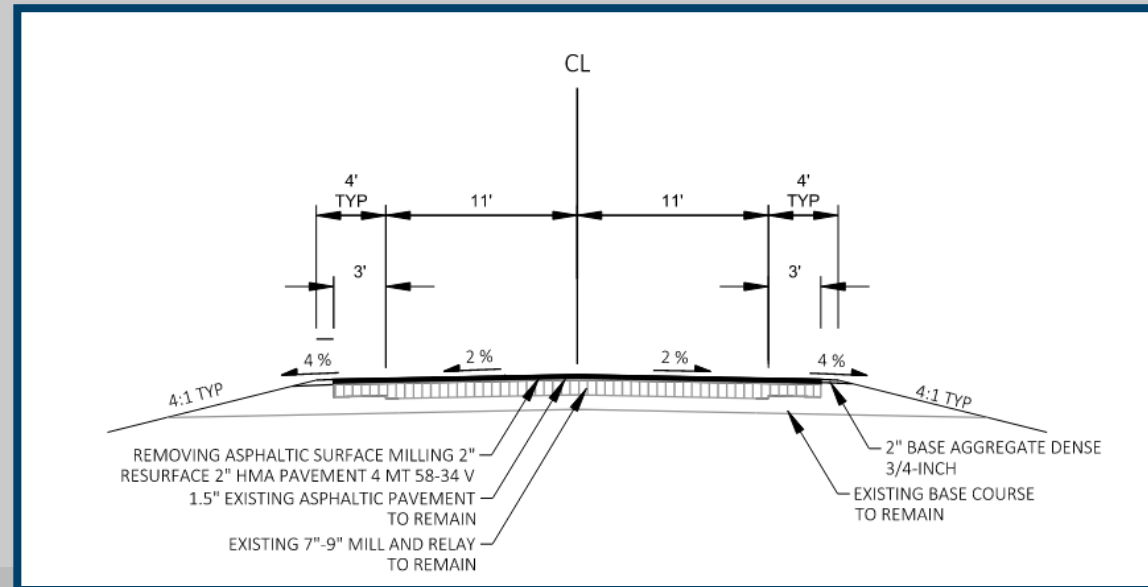

# Proposed Design Overview

## Typical Proposed Section – US 53 County V – Old Town Hall Rd

- Pavement

- 2-inch asphalt overlay

- Shoulders

- 3 feet paved, 2 feet gravel

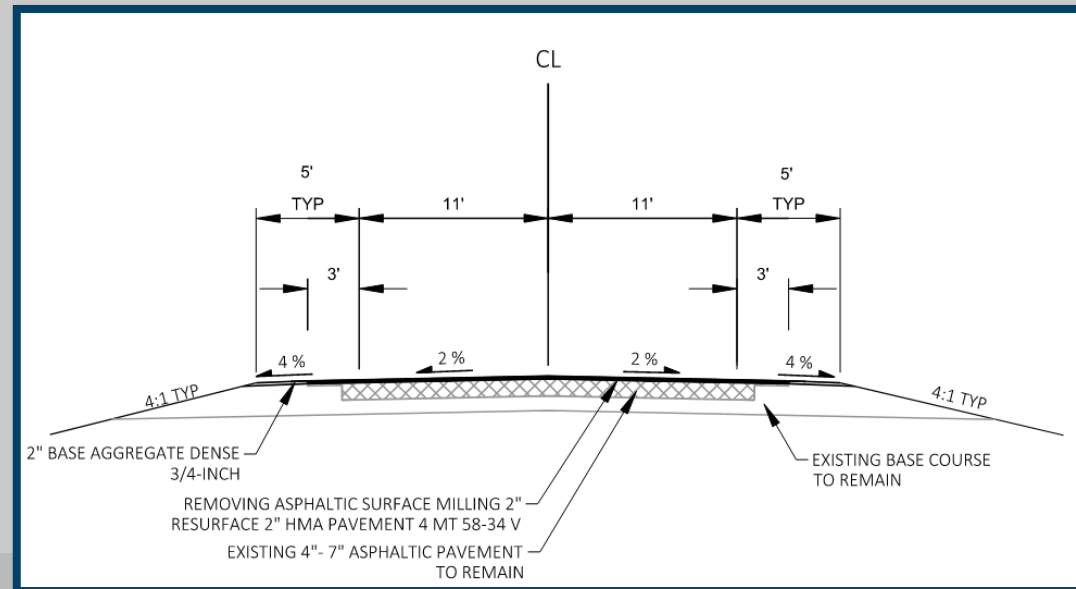

# Traffic Control

- US 53 will be closed to through traffic for the replacement of two sets of culvert pipe carrying Otter Creek.
  - Detour will use County HH and I-94.
- US 53 will remain open to traffic for other work, but motorists will encounter:
  - Single-lane closures
  - Speed limit reductions during roadway improvements

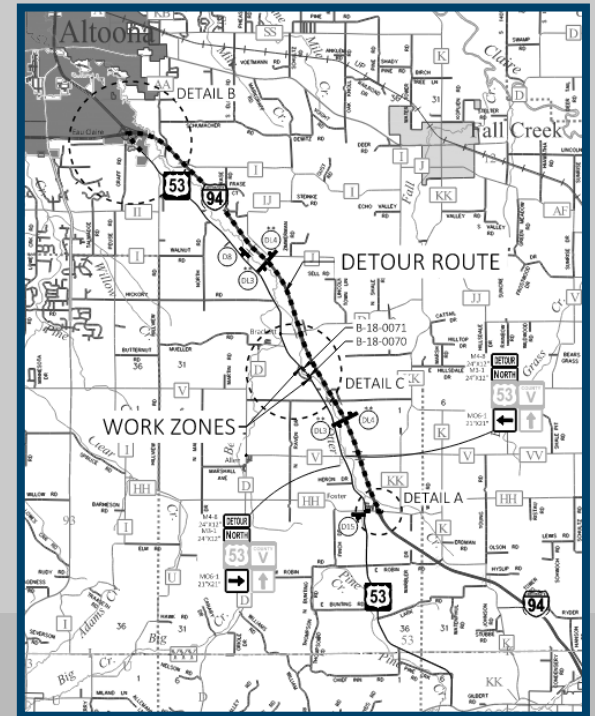



# Schedule



Preliminary design began:  
Spring 2023

Preliminary design and environmental process complete:  
Summer 2024

Final plan submittal:  
May 2026

Construction:  
Currently scheduled for summer 2029



# Project Contacts

- WisDOT Project Manager Nicholas Pitsch, PE
  - (715) 225-1271, [nicholas.pitsch@dot.wi.gov](mailto:nicholas.pitsch@dot.wi.gov)
- WisDOT Project Supervisor Jim Koenig, PE
  - (715) 838-8391, [james.koenig@dot.wi.gov](mailto:james.koenig@dot.wi.gov)
- Consultant Project Manager Kevin Meyer, PE – CORRE, Inc.
  - (715) 299-1894, [kmeyer@correinc.com](mailto:kmeyer@correinc.com)



# Public Comment

- WisDOT is accepting public comments on the proposed project through May 31, 2024, by:
  - Email: [nicholas.pitsch@dot.wi.gov](mailto:nicholas.pitsch@dot.wi.gov)
  - Mail: Wisconsin Department of Transportation  
718 W. Clairemont Ave.  
Eau Claire, WI 54701  
Attn.: Nick Pitsch

