



APPLICATION TO ERECT WHITE ARROWBOARD SIGNS ON THE STATE HIGHWAY SYSTEM

Wisconsin Department of Transportation
DT1903 3/2021

Submit completed application to Wisconsin Department of Transportation Regional Office

NAME of Business/Service/Activity:

Street:	City:	State:	ZIP Code:
Email Address:		(Area Code) Telephone Number:	

Proposed Sign Location Instructions:

1. Label the intersecting roads.
2. Place an arrow in the circle pointing to the North.
3. Check (X) one or two of the boxes corresponding to the proposed sign location(s).
4. Write the name of the county in the lower left corner.

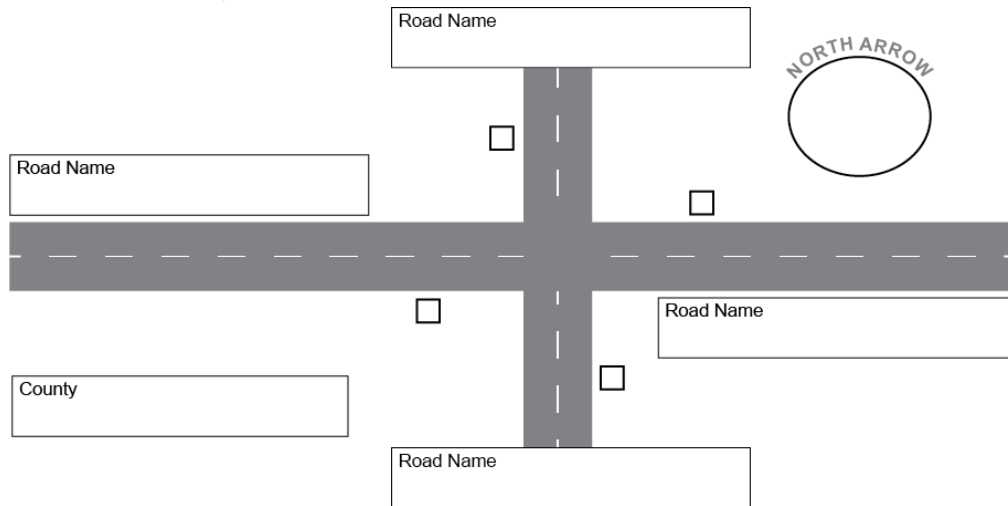

Proposed Sign Wording:

Figure 1: Fill in the name of the business. Limit the name to one character or space per box. Signs shall contain 4.5" black block lettering on a non-reflective background.

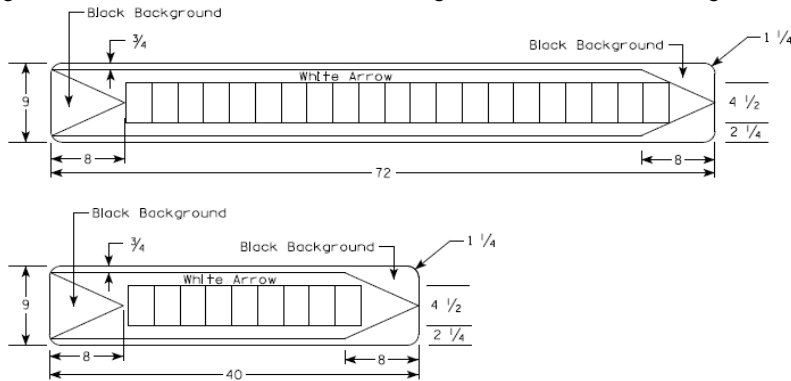

Number of Signs (select one):

- 1 Sign
- 2 Signs

Signs placed on (select one):

- New Posts
- Existing Posts

*Installation Fees:

- \$250/sign with new 4x6 posts
- \$100/sign with existing posts
- Payable to WisDOT

I apply for authority to erect and maintain guidance signs at the locations listed on this application. I certify and agree that these signs will conform to the approved design of the Wisconsin Department of Transportation and that I will comply with all the regulations under which authority these signs may be erected. I acknowledge that I would be responsible for the manufacturing and installation costs of the requested sign(s), and I certify that I will comply with the attached administrative codes and figures.

X

Applicant Signature

Date (m/d/yy)

X

WisDOT Region Signature

Date (m/d/yy)

APPROVED DENIED – Reason:

APPLICATION TO ERECT WHITE ARROWBOARD SIGNS ON THE STATE HIGHWAY SYSTEM

(continued)

Wisconsin Department of Transportation DT1903

Sign Erection Regulations

Extracted from Chapter Trans 200, Wisconsin Administrative Code

Trans 200.02 Authority for the erection of signs.

1. The Department of Transportation or its authorized representatives in the case of the marked routes of state trunk highways, and local authorities with respect to highways under their exclusive jurisdiction, may place and maintain such traffic signs and signals as they deem necessary to warn, guide, inform, and regulate traffic, and also such signs and signals as are expressly permitted or required by the statutes or by these regulations, subject, however, to such limitations and restrictions as are contained in the statutes and these regulations.
2. The Department of Transportation with respect to the state trunk highway system, and local authorities with respect to highways under their jurisdiction, may erect or permit any department of the federal, state or local government to erect such standard signs as the Department of Transportation or local authorities deem necessary to inform and warn the public of federal or state laws, local ordinances and lawful regulations by any such department.

Trans 200.03 Guidance signs for resorts, hotels, county institutions, etc.

1. Any person or persons conducting a summer or winter resort, hotel, or any place of public entertainment or instruction, or any place of religious worship, or persons having charge of any county institution or of any scientific experiment for the furtherance of agriculture or other science or art may be permitted to erect guidance signs of a type approved by the Department subject to the conditions contained in this section.
2. No guidance sign may be permitted on freeways, including the national system of interstate highways.
3. Only where such institution or business location is removed from the state trunk highway system may such guidance signs be erected.
4. Such guidance signs may be erected at only two intersections of the state trunk highway system with county highways or town roads, and at such intersections of county or town highways as are deemed necessary by the local authorities having jurisdiction over those highways.
5. One sign of an approved size and shape may be erected at the entrance to any of the enumerated institutions or businesses.
6. No person may be permitted to erect or maintain a guidance sign on a highway if that person has any advertising in the vicinity of the intersection where the guidance sign is proposed to be erected or has a business sign under 200.06 on the same highway.
7. All guidance signs erected on any public highway shall be of a type and design approved by the Department. No flashing, illuminated, or reflecting signs or installation shall be permitted.
8. No guidance sign may be erected upon state trunk highway right of way at an intersection with the state trunk highway system until the location and manner of erection of the have the written approval of the Department. No guidance sign may be erected on the right of way of a county and town highway until the location and manner of erection of the sign have the written approval of the local authorities having jurisdiction over the said highway.
9. All guidance signs and their supports shall be maintained in good condition. **Signs or installations not satisfactorily maintained shall be removed by the officers in charge of the maintenance of the highway.**

Trans 200.04 Prohibited signs and signals.

1. No person may erect, cause to be erected, permit to be erected or maintain any advertising, warning, route, guide, information, or regulatory sign or signal within the limits of any highway except as authorized in sections 200.02, 200.03, 200.05 or 200.06.
2. No person may place or maintain nor may any public authority permit upon any highway any official traffic control device bearing thereon any commercial advertising except as authorized in 200.06.

APPLICATION TO ERECT WHITE ARROWBOARD SIGNS ON THE STATE HIGHWAY SYSTEM

(continued)

Wisconsin Department of Transportation DT1903

Figure 2. Typical Installation Detail for Arrow Board Signs
(Supplement to form DT1903)

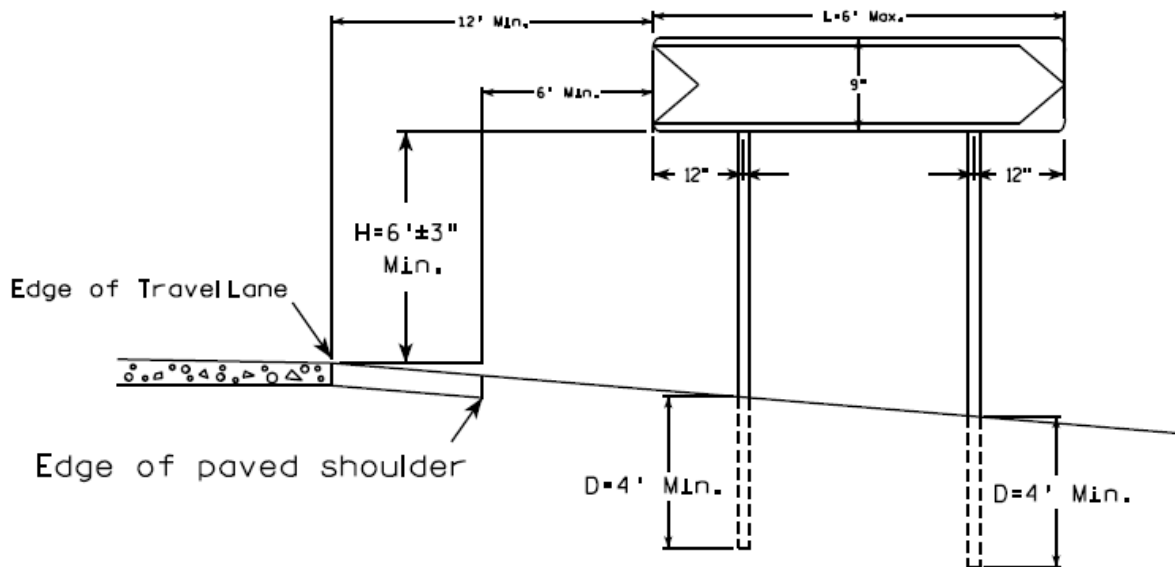

Sign Installation Requirements for Permittees & Counties:

1. Upon approval, the permittee shall be responsible for having the signs manufactured to state specifications (a non-reflective white arrow, on a non-reflective black rectangular background with rounded corners, consisting of 4 ½ inch black block lettering). A list of qualified manufacturers will be provided, from which the permittee can choose to have the signs manufactured (the permittee shall be responsible for all manufacturing costs).
2. After the signs are manufactured, the permittee is to drop them off at the county (some qualified manufacturers may ship signs directly to the county). Once received, the county will install the sign(s) at the approved location(s). Counties shall charge their installation costs to Project ID: 0080-02-63.
3. The permittee shall submit payment for the installation fees to cover the county's costs. **Costs are \$100/sign if installed on existing posts, or \$250/sign if new 4x6 posts are needed.** Checks shall be made to: Wisconsin Department of Transportation, and should be sent to Wisconsin Department of Transportation, Attn: Casey Amans, 3609 Pierstorff St, Madison, WI 53704. It is recommended the permittee drop off the check when delivering the signs to the county (the county will forward it to WisDOT), or it can be mailed directly to the above address.
4. Signs are to be mounted per dimensions shown above and are to project approximately 1 inch above the top of the post.
5. Sign posts are to be treated **4x6 wood suitable for ground contact** (4x4 wood posts shall not be used).
6. Signs less than 4 feet in length may be mounted on a single post; all other dimensions shown above apply.
7. If multiple signs are "stacked" on the same posts, all signs are to be the same length. In this case, the minimum mounting height shall be 5'3" for rural areas. Sign assemblies shall be limited to a maximum of six signs.
8. There may be a maximum of two guidance sign assemblies per intersection approach in the same direction (Maximum of total 12 signs, no more than 6 signs on each assembly). If a sign is approved at an intersection that already has two full assemblies, do not install and notify the WisDOT Region as soon as possible.
9. Contact Diggers Hotline prior to any excavation.
10. Signs are to be white arrows on a black, rectangular background with rounded corners (new design as of March 2021, replaced the traditional cut-out arrow design). Base material is aluminum. Do not install any signs that have reflective sheeting.
11. **All repair and replacement costs are the responsibility of the permittee.** If an existing sign is damaged or worn, the county should only repair or replace it with the permittee's approval. If a sign is repaired or replaced, the permittee shall be responsible for all manufacturing costs and the associated installation costs (same costs as noted in #3, payable to Wisconsin Department of Transportation). If the permittee elects not to repair a damaged sign, the county should remove it.